

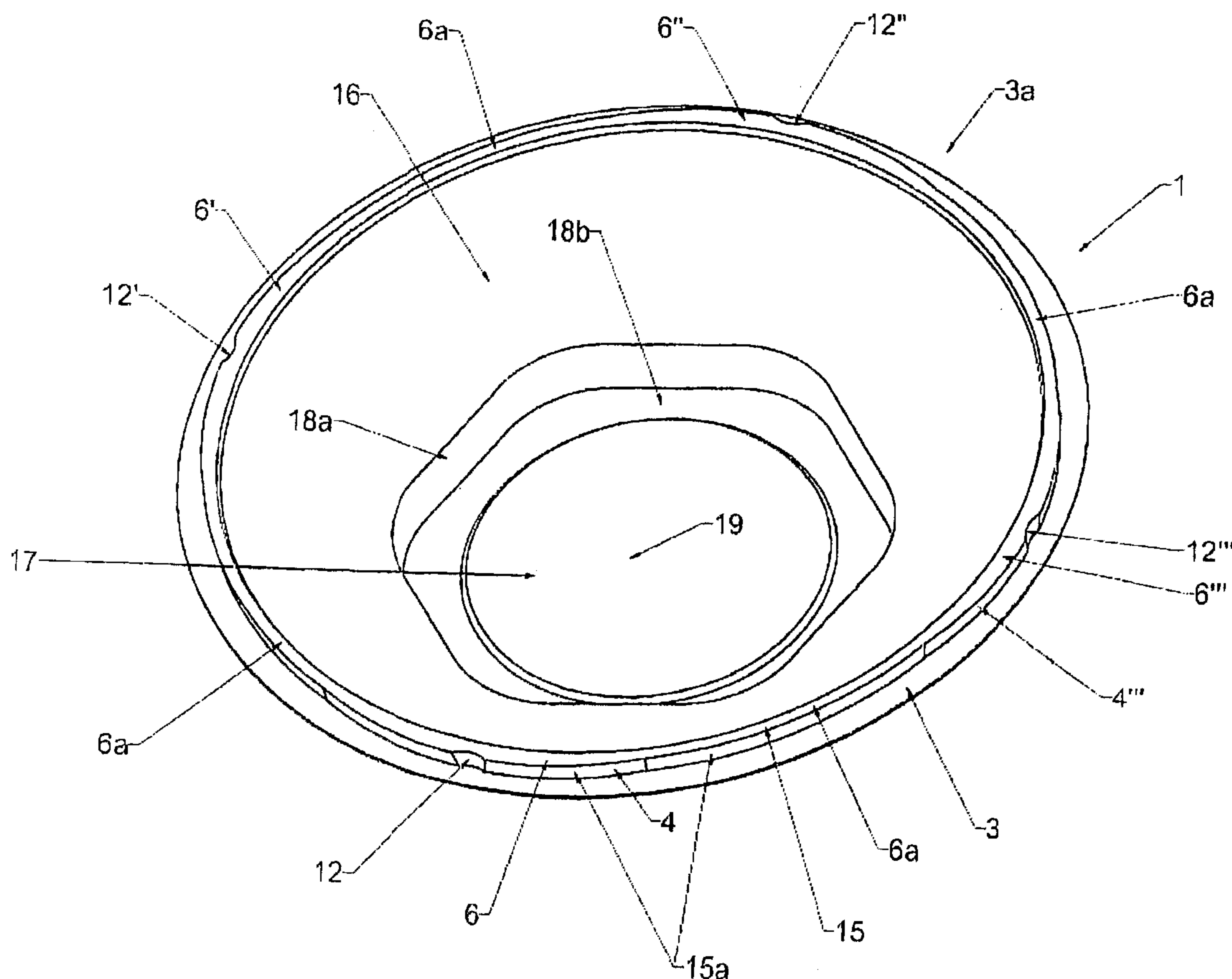

(86) Date de dépôt PCT/PCT Filing Date: 2004/10/07
 (87) Date publication PCT/PCT Publication Date: 2005/04/21
 (85) Entrée phase nationale/National Entry: 2006/04/06
 (86) N° demande PCT/PCT Application No.: EP 2004/011196
 (87) N° publication PCT/PCT Publication No.: 2005/035378
 (30) Priorité/Priority: 2003/10/07 (DE103 47 378.5)

(51) Cl.Int./Int.Cl. *B65D 43/02* (2006.01),
A47J 47/08 (2006.01)
 (71) Demandeur/Applicant:
HUHTAMAKI ALF ZWEIGNIEDERLASSUNG DER
HUHTAMAKI DEUTSCHLAND GMBH & CO. KG, DE
 (72) Inventeur/Inventor:
FRANZEN, HANS, DE
 (74) Agent: SIM & MCBURNEY

(54) Titre : CONTENANT
 (54) Title: CONTAINER



(57) **Abrégé/Abstract:**

The invention relates to a container comprising a bottom shell (1) and a cover shell (2), and means for locking the cover shell to the bottom shell. According to the invention, the opening edge (3) of the bottom shell, which is essentially circular, comprises at least

(57) **Abrégé(suite)/Abstract(continued):**

two first sections (6, 6", 6", 6") provided with an area which extends in a radial manner and at least one rear section (4, 4', 4", 4"). The cover shell (1) comprises, on the opening edge thereof (3'), at least two second sections (7, 7', 7", 7") in relation to the area which extends in a radial manner corresponding to the first sections. The second sections (7, 7', 7", 7") respectively comprise at least one rear section (5, 5', 5", 5") which corresponds to the rear section of the associated first section (6, 6", 6", 6"), such that when the bottom shell (1) is rotated in relation to the cover shell (2), it is locked in the region of the rear section of the first and the second associated sections.

(12) NACH DEM VERTRAG ÜBER DIE INTERNATIONALE ZUSAMMENARBEIT AUF DEM GEBIET DES
PATENTWESENS (PCT) VERÖFFENTLICHTE INTERNATIONALE ANMELDUNG(19) Weltorganisation für geistiges Eigentum
Internationales Büro(43) Internationales Veröffentlichungsdatum
21. April 2005 (21.04.2005)

PCT

(10) Internationale Veröffentlichungsnummer
WO 2005/035378 A1(51) Internationale Patentklassifikation⁷: **B65D 43/02,**
A47J 47/08**DER HUHTAMAKI DEUTSCHLAND GMBH & CO.**
KG [DE/DE]; Bad Bertricher Strasse 6-9, 56859 Alf/Mosel
(DE).

(21) Internationales Aktenzeichen: PCT/EP2004/011196

(72) Erfinder; und

(22) Internationales Anmeldedatum:
7. Oktober 2004 (07.10.2004)(75) Erfinder/Anmelder (*nur für US*): **FRANZEN, Hans**
[DE/DE]; Kirchstrasse 29, 56859 Bullay (DE).

(25) Einreichungssprache: Deutsch

(74) Anwälte: **FUCHS, Jürgen, H.** usw.; Söhnleinstrasse 8,
65201 Wiesbaden (DE).

(26) Veröffentlichungssprache: Deutsch

(30) Angaben zur Priorität:
103 47 378.5 7. Oktober 2003 (07.10.2003) DE(81) Bestimmungsstaaten (*soweit nicht anders angegeben, für
jede verfügbare nationale Schutzrechtsart*): AE, AG, AL,
AM, AT, AU, AZ, BA, BB, BG, BR, BW, BY, BZ, CA, CH,
CN, CO, CR, CU, CZ, DK, DM, DZ, EC, EE, EG, ES, FI,
GB, GD, GE, GH, GM, HR, HU, ID, IL, IN, IS, JP, KE,(71) Anmelder (*für alle Bestimmungsstaaten mit Ausnahme von
US*): **HUHTAMAKI ALF ZWEIGNIEDERLASSUNG**

[Fortsetzung auf der nächsten Seite]

(54) Title: CONTAINER

(54) Bezeichnung: BEHÄLTER

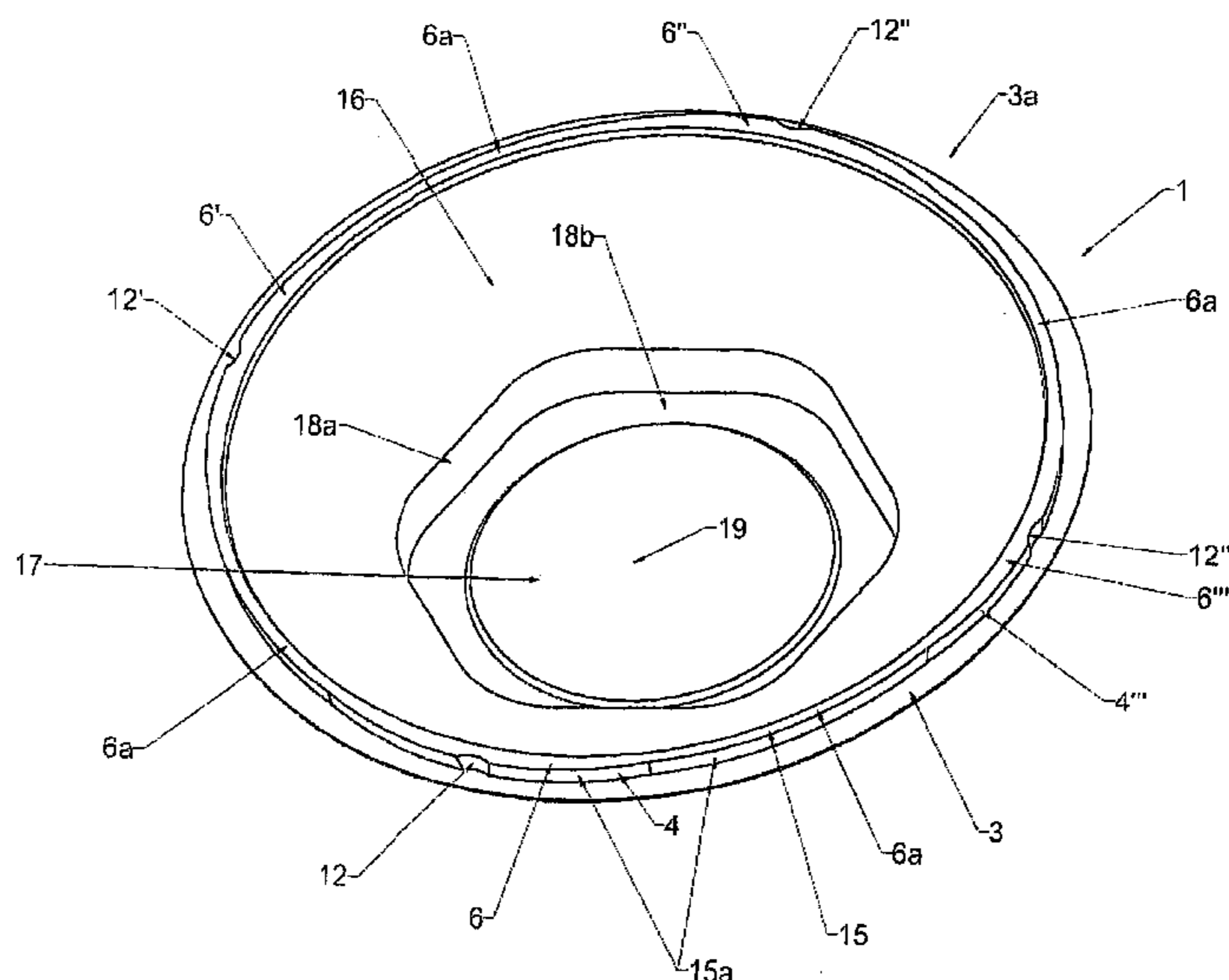

(57) **Abstract:** The invention relates to a container comprising a bottom shell (1) and a cover shell (2), and means for locking the cover shell to the bottom shell. According to the invention, the opening edge (3) of the bottom shell, which is essentially circular, comprises at least two first sections (6, 6', 6'', 6''') provided with an area which extends in a radial manner and at least one rear section (4, 4', 4'', 4'''). The cover shell (1) comprises, on the opening edge thereof (3'), at least two second sections (7, 7', 7'', 7''') in relation to the area which extends in a radial manner corresponding to the first sections. The second sections (7, 7', 7'', 7''') respectively comprise at least one rear section (5, 5', 5'', 5''') which corresponds to the rear section of the associated first section (6, 6', 6'', 6'''), such that when the bottom shell (1) is rotated in relation to the cover shell (2), it is locked in the region of the rear section of the first and the second associated sections.

(57) **Zusammenfassung:** Die Erfindung betrifft einen Behälter, mit Bodenschale (1) und Deckelschale (2), und mit Mitteln zum Verriegeln der Deckelschale mit der Bodenschale. Es wird vorgeschlagen, dass der im wesentlichen kreisrunde Öffnungsrand (3) der Bodenschale über mindestens zwei mit radialer Erstreckung ausgestattete, jeweils mindestens einen Hinterschnitt (4, 4', 4'', 4''') aufweisende erste Abschnitte (6, 6', 6'', 6''') verfügt, dass die

[Fortsetzung auf der nächsten Seite]

WO 2005/035378 A1

WO 2005/035378 A1

KG, KP, KR, KZ, LC, LK, LR, LS, LT, LU, LV, MA, MD, MG, MK, MN, MW, MX, MZ, NA, NI, NO, NZ, OM, PG, PH, PL, PT, RO, RU, SC, SD, SE, SG, SK, SL, SY, TJ, TM, TN, TR, TT, TZ, UA, UG, US, UZ, VC, VN, YU, ZA, ZM, ZW.

RO, SE, SI, SK, TR), OAPI (BF, BJ, CF, CG, CI, CM, GA, GN, GQ, GW, ML, MR, NE, SN, TD, TG).

Erklärung gemäß Regel 4.17:

— *Erfindererklärung (Regel 4.17 Ziffer iv) nur für US*

Veröffentlicht:

— *mit internationalem Recherchenbericht*

(84) Bestimmungsstaaten (soweit nicht anders angegeben, für jede verfügbare regionale Schutzrechtsart): ARIPO (BW, GH, GM, KE, LS, MW, MZ, NA, SD, SL, SZ, TZ, UG, ZM, ZW), eurasisches (AM, AZ, BY, KG, KZ, MD, RU, TJ, TM), europäisches (AT, BE, BG, CH, CY, CZ, DE, DK, EE, ES, FI, FR, GB, GR, HU, IE, IT, LU, MC, NL, PL, PT,

Zur Erklärung der Zweibuchstaben-Codes und der anderen Abkürzungen wird auf die Erklärungen ("Guidance Notes on Codes and Abbreviations") am Anfang jeder regulären Ausgabe der PCT-Gazette verwiesen.

Deckelschale (1) an ihrem Öffnungsrand (3') über mindestens zwei, bezüglich der radialen Erstreckung zu den ersten Abschnitten korrespondierende zweite Abschnitte (7, 7', 7'', 7''') verfügt, dass die zweiten Abschnitte (7, 7', 7'', 7''') jeweils mindestens einen Hinterschnitt (5, 5', 5'', 5''') aufweisen der zu dem Hinterschnitt des zugehörigen ersten Abschnitts (6, 6', 6'', 6''') korrespondiert, so dass es bei einer Drehung der Bodenschale (1) relativ zu der Deckelschale (2) zu einer Verriegelung im Bereich der Hinterschnitte der ersten und zugeordneten zweiten Abschnitte kommt.

PCT/EP2004/011196

H 1709 WO ME/WOS

July 11, 2006

HUHTAMAKI ALF

2005013448

- 1 -

Container

The invention relates to a container with bottom shell and cover shell and with means for interlocking the cover shell with the bottom shell.

Such a container is for example known from US 3,830,395 A.

Such containers are used for storing and transporting all kinds of small items, particularly including food products, as, for instance, fresh cheese, yoghurt, and similar, and, in the case of the latter, also salad mixtures, which are provided with dressing or to which only the dressing needs to be added.

Conventional containers, for example for yoghurt, with locking or interlocking means that are as simple and as economically priced as possible, are provided with a bottom shell with corresponding cover shell, the cover shell having, in the area of the opening rim, a so-called cover skirt with catch elements, which reach under the shell rim. When opening the container, the cover skirt is pulled over the opening rim. For this purpose, it is necessary to reach under the cover skirt, to loosen the snap lock, and to remove the cover. This is not only unhandy but involves the risk of the fingers coming into contact with the container contents.

The invention is based on the technical problem of providing a container, the interlocking means of which allow, on the one hand, firm interlocking between bottom shell and cover shell and, on the other hand, easy opening, and offer the possibility of even holding the container overhead, without causing the interlock to be loosened.

The solution of this technical problem is achieved by the characteristics of the independent claim. Advantageous enhancements are set forth by the dependent claims.

According to the invention, it became obvious that the above-stated technical problem can be solved by a container with a bottom shell and a cover shell and with means for interlocking the cover shell with the bottom shell, wherein the substantially circular opening rim of the bottom shell has at least two first sections with radial extension, each having at least one undercut, the cover shell having, at its opening rim, at least two second sections which correspond to the first sections as far as the radial extension is concerned, and each of the second sections having at least one undercut which corresponds to the undercut of the the appertaining first section so that, during a rotation of the bottom shell relative to the cover shell, interlocking takes place in the area of the undercuts of the first and associated second sections.

As undercut, one considers most particularly a slant, which allows positive locking with a corresponding counterpart. Particularly, lugs that can be grasped from behind are not undercuts according to the invention.

The radial extension denotes horizontal rim areas of the shell and/or bottom shell, which extend radially outward or inward.

The solution has the advantage that, even in the case of major forces perpendicular to the plane spanning the opening rim, the container remains tightly closed and that, in spite of the high locking force, easy unlocking is possible.

Moreover, the lock has the advantage that in case of light, solid items or of liquids in the container, nothing reaches the outside during opening. If, for example, a salad with a salad dressing is inside the container, there is no risk of salad dressing spurting out when the container is opened, and getting the user's hands dirty.

For closing and opening, bottom shell and cover shell are rotated against each other. Depending on the embodiment of the first and second sections, closing and opening can take place in the same direction of rotation. It is, however, also possible to close the container by a rotation to the right and opening it by rotating to the left. The first sections are preferably formed by radial increases in width¹ of the bottom shell rim.

These radial increases in width can be designed in symmetry or in asymmetry to a radial intersecting line. In the first case, the opening rim has jaw-like increases in width, by means of which, while retaining the direction of rotation, the container can be closed and opened. These first sections alternate in a peripheral direction with unwidened sections of the opening rim so that, when setting on the cover shell, the corresponding second sections can be inserted there and then, by twisting bottom shell and cover shell, can be caused to engage with the first sections.

The perimeters of the first and second sections are preferably equal in length. It is, however, also possible, for example, to select for the first sections a larger perimeter than for the second sections of the cover shell. In any case, the perimeters of the unwidened sections of the opening rim of the bottom shell must be appropriately adapted.

¹typo: "Verbreitungen" (distributions, dispersions) instead of "Verbreiterungen"

WO 2005/035378

PCT/EP2004/011196

In the second case, as a result of the asymmetric sections, in a top view, the opening rim has a sawtooth-like structure. The corresponding second sections of the cover element form a sawtooth-like structure in the opposite direction. In this form of embodiment, closing of the container takes place by rotating bottom shell and cover element in one direction and opening by rotating in the opposite direction.

The undercuts of the first and second sections herein can, in fact, also be designed corresponding to each other, but different.

It is possible for the first and the corresponding second section to show the shape of the letter Z in a cross section. This simple profile provides an undercut in the section that is slanted downward and toward the container interior. The areas that extend outward and/or inward assure that, in the locked state, the corresponding undercuts of the first and the second sections do not become separated from each other because otherwise the locking force would be reduced or lost.

Furthermore, it is possible for the first and the corresponding second sections, in a radial cross section, to show a profile that comprises three radial extension areas, between which at least one undercut as well as, as the case may be, an area that is substantially oriented perpendicular to the plane of the opening rims, is arranged. As a result, the hold of the cover, compared to a Z-profile, is over again improved.

In an advantageous enhancement, the first and the second sections have an undercut that is designed thread-shaped. In this case, the slope of the undercut of the first section relative to perpendicular changes in the peripheral direction, initially increases to cause the appertaining second section to become additionally wedged, thereby increasing the locking force over again. The undercut surface herein is subjected to torsion up to the middle of the section along the peripheral direction, around a peripheral line. After passing the middle, the slope of the undercut decreases again, in order to allow opening of the container. Hence, interlocking, both via an rotation to the left and a rotation to the right is possible.

In addition to the above-stated designs of the undercuts, it is possible for each of the first and the second sections to have at least one thread cord. In this form of embodiment, in each case, the undercut is formed by the thread cord.

A further design provides for the first and the second sections to have ramps that correspond to each other, and the ramps can be designed thread-shaped, too.

Each ramp has at least one ramp surface, which is sloped in the peripheral direction. The ramp surfaces of the bottom shell preferably extend from the opening rim downward. The ramp surfaces of the cover shell are designed in a corresponding manner, with the effect that, during closing of the container, the ramp surfaces slide on each other, thereby causing bottom shell and cover shell to move on top of each other.

For each first and second section, two or more ramp surfaces can furthermore be combined.

The ramps offer the advantage that the axial extension of the undercut surfaces of the first and second sections becomes enlarged, thereby improving interlocking.

In order to offer the user an aid about when the container is optimally closed, it is possible to provide for each of the first and the second sections in the area of their greatest radial distance from the center of the opening rim concerned to have a marking. It suffices if at least one of the sections concerned is provided with an appropriate marking to indicate to the user of the container the optimal locked position by matching markings. The marking can, for instance, be a color marking, a symbol, such as a triangle or an arrow. In addition to this visual aid for optimal interlocking of the container, the marking may also be selected in the form of a notch, a depression, or designed in another manner, thereby, in addition to the visual aid, providing the user a tactile means for detecting the optimal locked position.

For carrying out the rotary movement by hand, the container may be provided with rotation aids. Particularly for domed containers with a smooth surface, the possibility suggests itself of providing the cover shell and/or the bottom shell with a plurality of recesses or bulges. These may be molded into the cover shell and/or the bottom shell and be dimensioned in such a way that a finger tip can be placed therein. Thereby, the hold of the fingers while turning is improved and the ease of use is increased.

For the same purpose, moreover an embodiment can be selected, in which the lower area of the bottom shell and/or the cover shell is designed polygonally, e.g. in the form of a triangle or a rhomb. In this case, the container also has a gripping aid, which prevents the fingers from slipping off when using the container.

WO 2005/035378

PCT/EP2004/011196

Preferably, in the locking area, the bottom shell or the cover shell is equipped with a gasket. In the rim area, the gasket is preferably molded on. The gasket may be arranged situated inside and is pressed inward during assembly of cover shell and bottom shell.

According to a special embodiment, the gasket can be formed by rim areas of cover shell and bottom shell, which are adjacent to each other in the closed stated. In order to assure close adjacency of the rim areas, the combination with a thread-like embodiment of the undercuts is preferred because during unscrewing of the cover, the rim areas are pressed against each other. This causes warping which assures tight sealing.

Preferably, the rim area of the cover shell is adjacent to the inside of the bottom shell. As a result, the sealing area is transferred into the interior of the bottom shell which has the advantage that no fluid can penetrate into the lock area, in particular the area of the undercuts. After removing the cover shell, this lock area is clean so that the user's fingers don't become dirty when gripping and transporting the bottom shell. A clean lock area has the additional advantage that the operation of the locking elements is not impaired.

Preferably, the cover shell is provided with a rim indent, which extends into the interior of the bottom shell. As a result, it becomes possible to transfer the sealing area into the interior of the bottom shell in a simple manner.

Bottom shell and cover element are preferably manufactured of plastic material and by the deep-drawing process. Hereinafter, the invention will be explained in greater detail based on the figures showing in:

Fig. 1 A lateral top view of the interior of the bottom shell;

Fig. 2a a lateral top view of the outside of cover shell 2;

Fig. 2b a lateral top view of the inside of the cover shell,

Fig. 3 a closed container in a lateral view;

Fig. 3a-3d

cross sections of the lock area in a radial direction;

Fig. 4 form of embodiment of the lock area with ramps;

Fig. 5 radial cross section of a ramp of the bottom shell;

Fig. 6 a lateral top view of the interior of the bottom shell according to a further form of embodiment;

Fig. 7 a lateral top view of the outside of a cover shell 2 matching the bottom shell according to Fig. 6.

Figure 1 shows a lateral top view of a bottom shell 1 with a view into the interior of the bottom shell. Circular opening rim 3 has a circular outward oriented horizontal subarea 3a. Above and on the plane spanning subarea 3a of opening rim 3, a substantially cylindrical rise 15 is located. Rise 15 has a total of four first sections 6, 6', 6'', 6''' with radial extension, the radius of curvature of which is substantially smaller than the circular opening radius. These widened sections 6, 6', 6'', 6''' are symmetrically designed. Sections 6, 6', 6'', 6''' alternate with areas 6a that are not radially widened and extend over a certain peripheral area of the opening rim.

In deviation from the above-described design of opening rim 3 of bottom shell 1, additionally, a design is furthermore possible, in which opening rim 3 does not have a flat radially oriented horizontal subarea 3a but, at wall 16 of bottom shell 1, passes directly into outer perimeter wall 15a of rise 15 and the first sections 6, 6', 6'', 6''', e.g. via a molding of the sections 6, 6', 6'', 6''' from the outside onto the container wall.

The perimeter of the sections 6a is equal to or greater than the perimeter of the sections 6, 6', 6'', 6'''.

Each of the four first sections 6, 6', 6'', 6''' shown in Figure 1 has, on outer perimeter wall 15a, an undercutting or an undercut 4, 4', 4'', 4''' respectively, of which, because of the perspective of the illustration, only two can be seen, namely the undercuts 4 and 4''' of the first sections 6 and 6'''. Undercut 4 is formed by a slope of outer perimeter wall 15a of sections 6, 6', 6'', 6'''. The simplest geometry exists whenever each of the undercuttings extends over the entire perimeter of sections 6, 6', 6'', 6'''.

Optionally, at least one of the first sections 6, 6', 6", 6''' has a marking 12. Herein, bottom shell 1 shows four markings 12, 12', 12", 12''' in the form of a notch. The notches 12, 12', 12", 12''', designed in round form, are centrally located in sloped wall 15a, which forms the undercuttings 4, 4', 4", 4'''.

Bottom shell 1 has, as a rule, any desired shape below the substantially circular opening rim 3. In Figure 1, wall 16 below opening rim 3 is designed in cylinder-symmetrical form. This cylinder-symmetrical wall 16 is adjoined by a bulge 17, which is designed polygonally. In Figure 1, this bulge 17 is hexagonal, projects outward, is molded onto bottom shell 1, and when holding bottom shell 1 from the rear, is used for better retaining the hold by the hand while carrying out the rotary movement. The hexagonally designed area 18a is adjoined by base 18b and surface 19 which is slightly raised against base 18b.

Figure 2a shows a cover shell 2 from above in a lateral downward view. The view is oriented to the outside of cover shell 2.

Cover shell 2 also has a substantially circular opening rim 3', which is flat and outward oriented. The radius of this opening rim 3' corresponds to that of opening rim 3 of bottom shell 1. Corresponding to the first sections 6, 6', 6", 6''' of bottom shell 1, cover shell 2 has second sections 7, 7', 7", 7''' with a slightly greater radial extension than² the first sections 6, 6', 6", 6''' of bottom shell 1, which alternate in the peripheral direction with the radially outward projecting sections 7a. Insofar, the second sections 7, 7', 7", 7''' correspond to the first sections 6, 6', 6", 6''' and the areas 6a to the sections 7a. The perimeter of the second sections 7, 7', 7", 7''' herein correspond to the perimeter of the first sections 6, 6', 6", 6'''. Between the sections 7, 7', 7", 7''' and the vaulted cover wall, there is an annular rim indent 2a, which extends into the interior of bottom shell 1.

²Grammatical error here; German "wie" would actually translate to "like" (in the meaning of "just like") but since it is a well-known German regional grammatical error, we ignored it in English

In the upper central area of cover shell 2, recesses 13 can be recognized pointing into the container interior. They allow positioning the fingers of the user in the recesses 13 and prevent slipping off while closing or opening the container.

Fig. 2b shows cover shell 2 from above in a lateral downward view, this time the view being oriented into the interior. The second, inward projecting sections 7, 7', 7'', 7''' of cover shell 2 with appertaining undercuts 5, 5', 5'', 5''' can be recognized, as a result of the perspective, only two of them, namely 5 and 5'', of the second sections 7 and 7'' being visible. In this illustration, the undercuts 5, 5', 5'', 5''' of cover shell 2 are formed by a constant slope of inner perimeter wall 15b.

The first and second sections 6, 6', 6'', 6''' and 7, 7', 7'', 7''' provide, in the form of the undercuts 4 and 5, conical surfaces which interlock during a rotary movement of bottom shell 1 relative to cover shell 2 by positive locking. The markings, for example in the form of a colored marking or of projections 12a, 12a', 12a'', 12a''' as in Figure 2b indicate the optimal position for firm locking.

While a total of four markings 12 are provided in the bottom shell, it suffices if, in deviation from Fig. 2b, only one marking 12a is provided in cover shell 2.

In Fig. 2b, gasket 14 is additionally drawn in on the inner rim of opening rim 3.

According to Figure 3, a container with cover shell 2 and bottom shell 1 can be recognized, the lock area of which is rimmed on the right outside via a circle. This marked area is presented in Figures 3a-d enlarged on the bottom in a cross section.

In Figs. 3a-d, rim indent 2a of cover 2 can be seen, being molded in in annular form. Vaulted cover wall 2b extends into the interior of bottom shell 1 and passes into an ascending rim section 14b, which is adapted to the contour of rim section 14a of bottom shell 1. When setting and/or screwing cover shell 2 onto bottom shell 1, the rim sections 14a, 14b are pressed against each other so that a gasket 14 forms. Hence, liquid in the interior of the container cannot get as far as into the lock area of the undercuts 4, 5.

According to Figure 3a, cover shell 2 may have, in its outer area, a first section with Z-shaped profilation and insofar possesses an undercut 5, which is formed by a slanted surface. Bottom shell 1 has, corresponding thereto, a second section with Z-shaped profile and also an appertaining undercutting 4. Hence, cover and bottom shell have two radial extensions or rim areas 8, 8". As a result of the pressing pressure exerted when screwing together cover and bottom shell onto the rim sections 14a, b, area 8 can stand up, which is drawn by the dashed line in Fig. 3A in exaggerated form. As a result, rim section 14b is additionally pulled inward and against rim section 14a. The connection between cover 2 and bottom shell 1 then takes place via positive locking.

In an additional embodiment according to Fig. 3b, the first and the corresponding second sections in the lateral view show a profile, which comprises three radial extension areas 8, 8', 8'', between which at least one undercut 4 or 5 as well as, as the case may be, a substantially vertically running area 9 is arranged, compare Fig. 3b.

In the form of embodiment shown in Fig. 3c, the undercut surfaces shown in Fig. 3b are formed by vertical surfaces. The undercuts 4, 5 are created by setoff 30, which is also present in Fig. 3b.

An additional embodiment provides for the first and the second sections to have thread cords 10, 10' that correspond to each other.

Each of the undercut surfaces 4 and 5 can represent a substantially vertically running surface while not being conically designed themselves, compare Fig. 3d. This surface has thread cords 10, 10', which, in turn, have an undercut.

In an additional advantageous enhancement (Fig. 4), the first and the second sections have ramps 11 and/or 11' that correspond to each other. Ramp 11 of cover shell 2 has a triangular lateral wall 22 with ramp surfaces 24 and 24'. Corresponding thereto, the bottom shell has a triangular lateral wall 23 with ramp surfaces 25 and 25'. At the seam location of the ramp surfaces 24 and 24' and/or 25 and 25', a bulge 20' and/or a depression 20 corresponding thereto is located. During closing, bulge 20' snaps into depression 20, and the ramp surfaces 24, 24', 25, 25' concerned of bottom shell 1 and cover 2 are in surface contact with each other. Via the surface contact of the sloped surfaces of the undercuts of both ramps which project into the ramps 11, 11', locking is caused. The snapping of bulge 20' into depression 20 herein represents a tactile aid optional to the ramp for determining the optimal locked position.

WO 2005/035378

PCT/EP2004/011196

Via lateral wall 23, undercut 4 and appertaining bottom wall 28, a channel is defined (see Fig. 5), into which the appertaining ramp 11 of cover shell 2 can drive. As a result of this solution, undercut 4 of bottom shell 1 is lengthened downward, thereby improving the positive lock. Vaulting 21 at the bottom of the channel represents the interlocking element of the container shell.

Figures 6 and 7 show a further embodiment of the container according to the invention. Fig. 6 shows a bottom shell 1 with four first sections 6, 6', 6'', 6''', which completely encompass opening rim 3 of bottom shell 1 without any gap. Every first section 6, 6', 6'', 6''' has a continually increasing radial extension outward. After reaching the maximum radial extension, an additional first section 6, 6', 6'', 6''' starts with an initially small and subsequently increasing radial extension. This results in the formation of corners 26, 26', 26'', 26''' and, in a top view, a sawtooth-like embodiment. Every section 6, 6', 6'', 6''' has, over the entire perimeter extension, an undercut 4, 4', 4'', 4'''.

Fig. 7 shows cover shell 2, corresponding to Fig. 6, with corresponding second sections 7, 7', 7'', 7'''. While for the first sections 6, 6', 6'', 6''' according to Fig. 6, the radial extension increases clockwise, it increases counter-clockwise for cover shell 2, compare Fig. 7. In the case of cover shell, the formation of corners 27, 27', 27'', 27''' and a corresponding sawtooth structure occurs, too. Thus, during closing, a positive lock occurs in the area of the first sections 6, 6', 6'', 6''' of bottom shell 1, namely in the area of the greatest radial extension.

In this form of embodiment, markings 12, 12', 12'', 12''' are also present in the form of notches or chases and inward oriented projections 12a, 12a', 12a'', 12a'''. The cover shell has recesses 13.

Reference Mark List

| | |
|-------------------------|-------------------------------------|
| 1 | Bottom Shell |
| 2 | Cover Shell |
| 2a | Rim Indent |
| 2b | Cover Wall |
| 3 | Opening Rim of Bottom Shell |
| 3a | Subarea of Opening Rim 3 |
| 3' | Opening Rim of Cover Shell |
| 4, 4', 4", 4''' | Undercut of Bottom Shell |
| 5, 5', 5", 5''' | Undercut of Cover Shell |
| 6, 6', 6", 6''' | First Section (of Bottom Shell) |
| 6a | Unwidened Area |
| 7, 7', 7", 7''' | Second Section (of Cover Shell) |
| 7a | Radially Outward Projecting Section |
| 8, 8', 8" | Radial Extension Area |
| 9 | Vertical Area |
| 10, 10' | Thread Cord |
| 11 | Ramp of Cover Shell |
| 11' | Ramp of Bottom Shell |
| 12, 12', 12", 12''' | Marking |
| 12a, 12a', 12a", 12a''' | Projection |
| 13 | Recess |
| 14 | Gasket |
| 14a | Rim Area |
| 14b | Rim Area |
| 15 | Cylindrical Rise |
| 15a | Outer Perimeter Wall |
| 15b | Inner Perimeter Wall |
| 16 | Wall |
| 17 | Bulge |

WO 2005/035378

PCT/EP2004/011196

| | |
|------------------|------------------------------|
| 18a | Hexagonal Area |
| 18b | Base |
| 19 | Raised Surface |
| 20 | Depression |
| 20' | Bulge |
| 21 | Vaulting |
| 22 | Lateral Wall of Cover Shell |
| 23 | Lateral Wall of Bottom Shell |
| 24,24' | Ramp Surface of Cover Shell |
| 25,25' | Ramp Surface of Bottom Shell |
| 26,26',26",26''' | Corner of Bottom Shell |
| 27 | Corner of Cover Shell |
| 28 | Bottom Wall |
| 30 | Setoff |

Claims

1. Container with bottom shell (1) and cover shell (2), and with means for interlocking the cover shell with the bottom shell, **characterized in**

that the circular opening rim (3) of bottom shell (1) has at least two first sections (6, 6', 6", 6''') provided with radial extension (8, 8', 8''), each having at least one undercut (4, 4', 4", 4'''),

that cover shell (2) has, at its opening rim (3'), at least two second sections (7, 7', 7", 7''') corresponding to the first sections as far as the radial extension (8, 8', 8'') is concerned,

and that each of the second sections (7, 7', 7", 7''') has at least one undercut (5, 5', 5", 5'''), which corresponds to the undercut (4, 4', 4", 4''') of the appertaining first section (6, 6', 6", 6''') so that, during a rotation of bottom shell (1) relative to cover shell (2), interlocking in the area of the undercuts (4, 4', 4", 4''', 5, 5', 5", 5''') of the first and associated second sections takes place.
2. Container according to Claim 1, **characterized in that** the first section (6, 6', 6", 6''') and the corresponding second section (7, 7', 7", 7'''), have, in a cross section, the shape of the letter Z.
3. Container according to Claim 1, **characterized in that** the first section (6, 6', 6", 6''') and the corresponding second section (7, 7', 7", 7''') have, in a cross section, a profile that comprises three radial extension areas (8, 8', 8''), between which at least one undercut (4) as well as, as the case may be, a vertical area (9) is arranged.

4. Container according to one of the Claims 1 to 3, **characterized in that** the first section (6, 6', 6", 6''') and the second section (7, 7', 7", 7''') have an undercut (4, 5) that is designed thread-like.
5. Container according to Claim 1, **characterized in that** the first section (6, 6', 6", 6''') and the second section (7, 7', 7", 7''') each have at least one thread cord (10, 10').
6. Container according to one of the Claims 1 to 5, **characterized in that** the first section (6, 6', 6", 6''') and the second section (7, 7', 7", 7''') have ramps (11, 11') that correspond to each other.
7. Container according to Claim 6, **characterized in that** the ramps (11, 11') are designed thread-like.
8. Container according to one of the Claims 1 to 7, **characterized in that** the first sections (6, 6', 6", 6''') and the second sections (7, 7', 7", 7''') have a continually increasing radial extension.
9. Container according to one of the Claims 1 to 8, **characterized in that** the first section (6, 6', 6", 6''') and the second section (7, 7', 7", 7''') each have, in the area of their greatest radial distance from the center of the opening rim concerned, a marking (12, 12', 12", 12''', 12a, 12a', 12a", 12a''').

10. Container according to one of the Claims 1 to 9, **characterized in that** the cover shell (1) and/or the bottom shell (2) have at least one recess (13, 17).
11. Container according to one of the Claims 1 to 10, **characterized in that** the lower area of bottom shell (1) and/or cover shell (2) is designed polygonally.
12. Container according to one of the Claims 1 to 11, **characterized in that** bottom shell (1) or cover shell (2) is equipped with a gasket (14) in the lock area.
13. Container according to one of the Claims 1 to 12, **characterized in that**, in the locked state, bottom shell (1) and cover shell (2), in each case, are situated on top of each other in at least one rim area (14a, b).
14. Container according to one of the Claims 1 to 13, **characterized in that** rim area (14b) of cover shell (2) is adjacent to the inside of the wall of bottom shell (1).
15. Container according to one of the Claims 1 to 14, **characterized in that** cover shell (2) has a rim indent (2a), which extends into the interior of bottom shell (1).

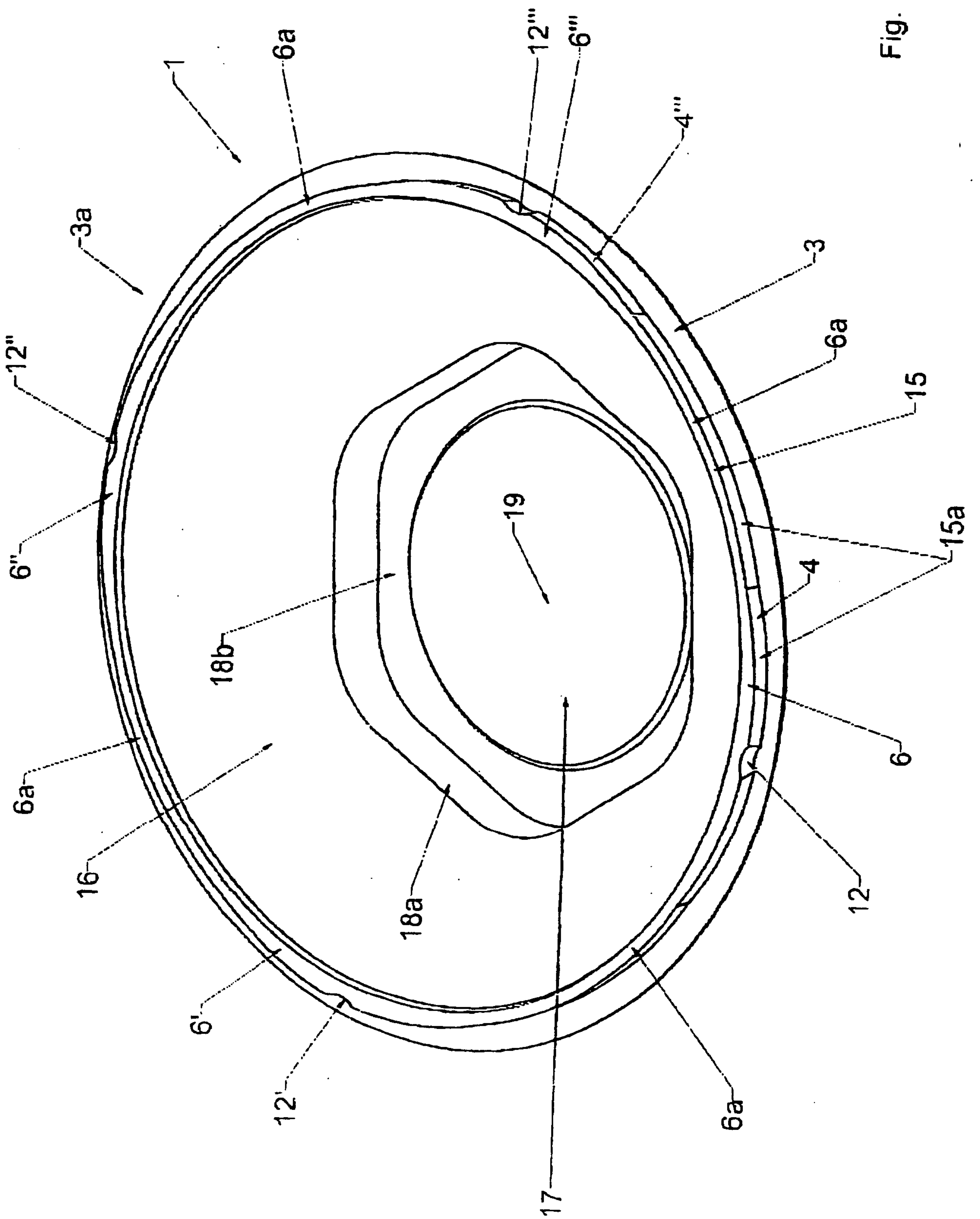

Fig. 1

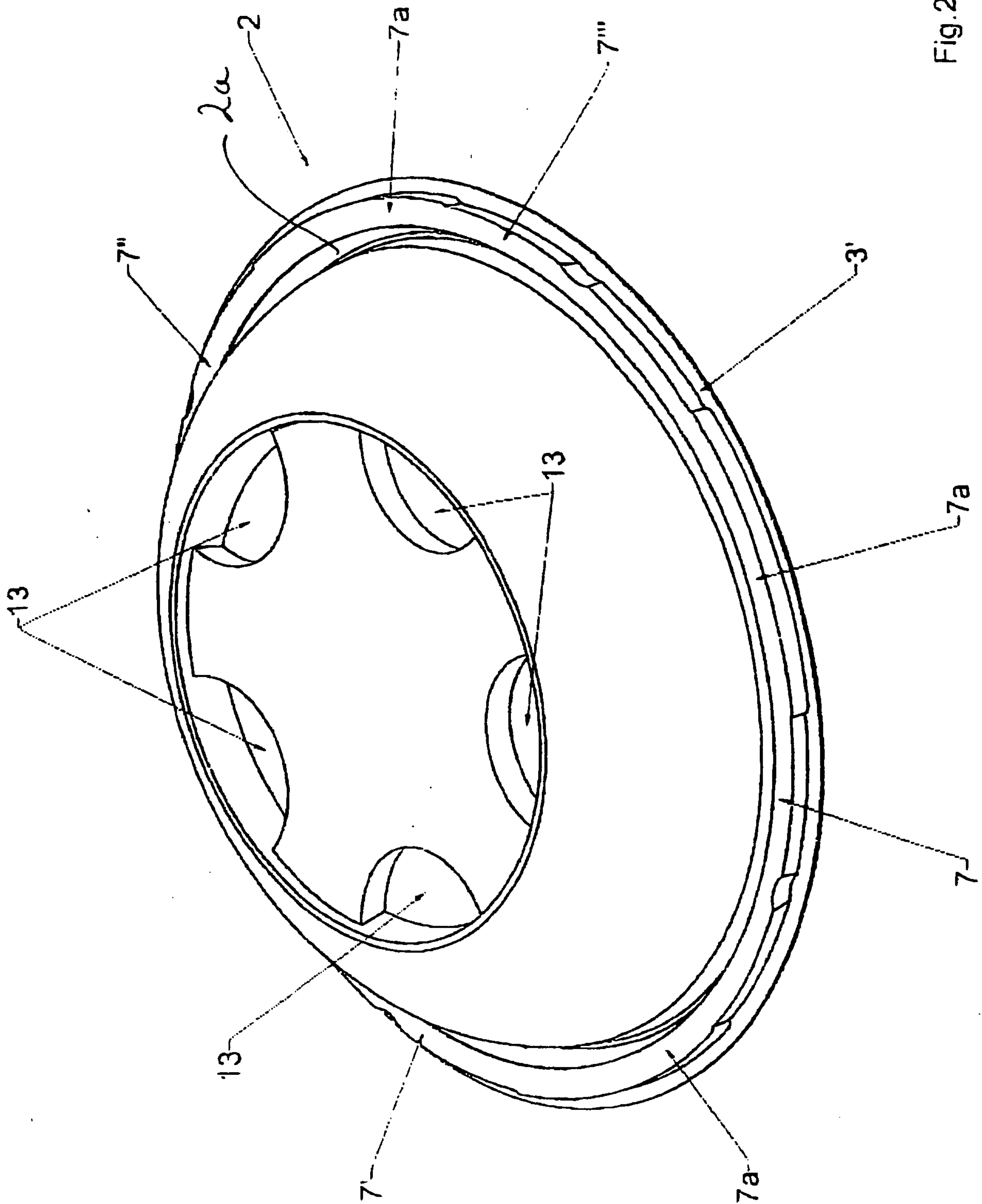

Fig.2a

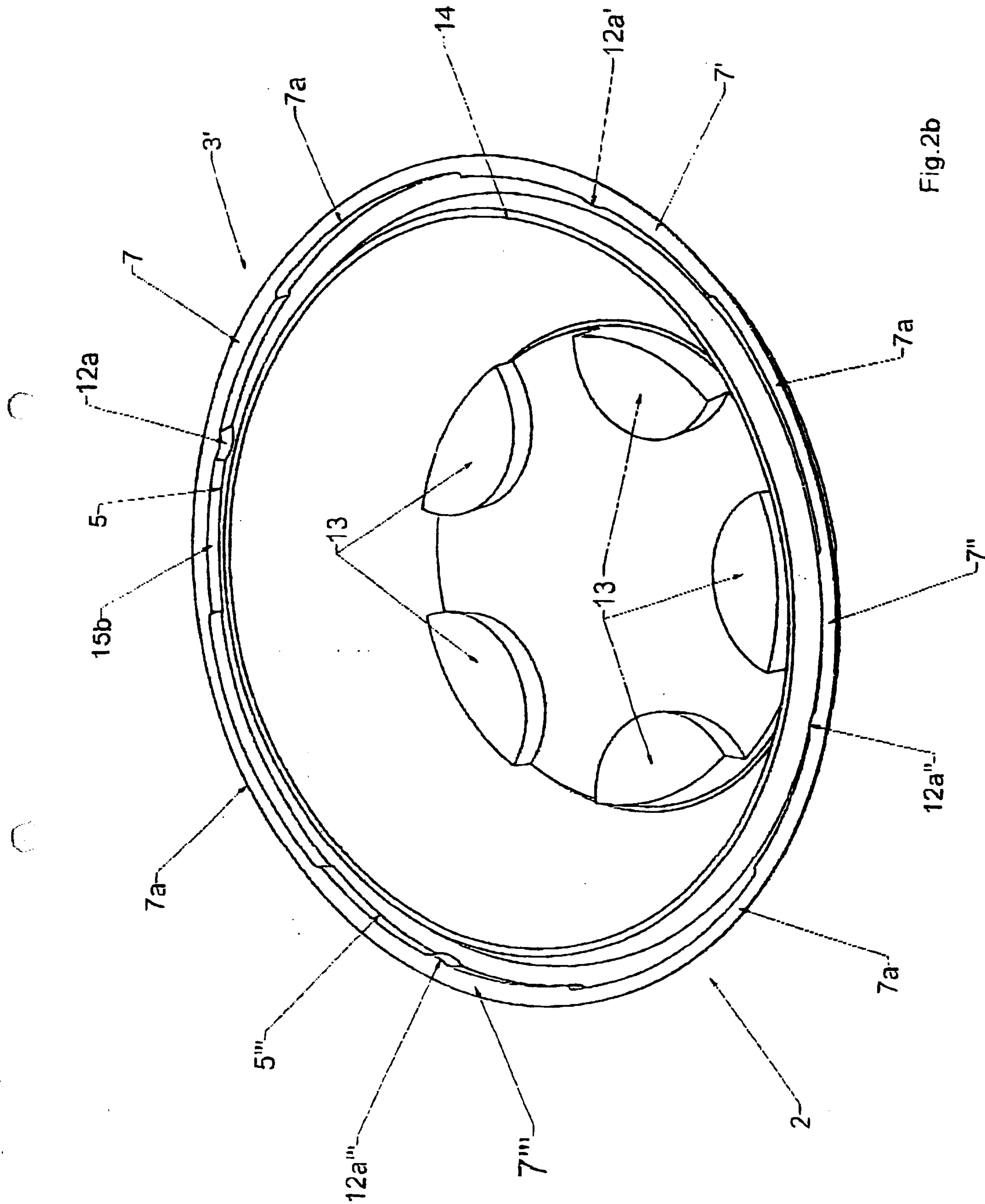
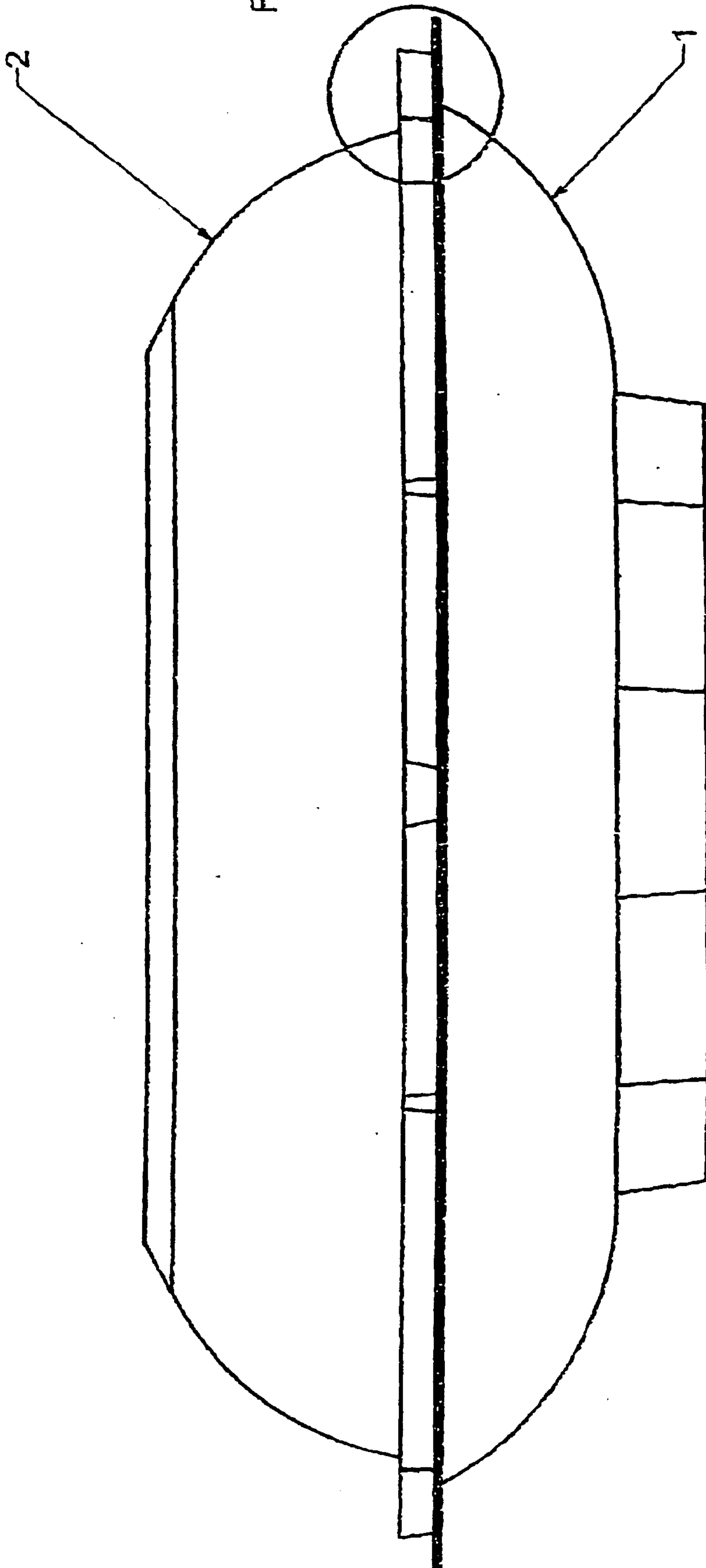

Fig.2b

Fig.3



5/10

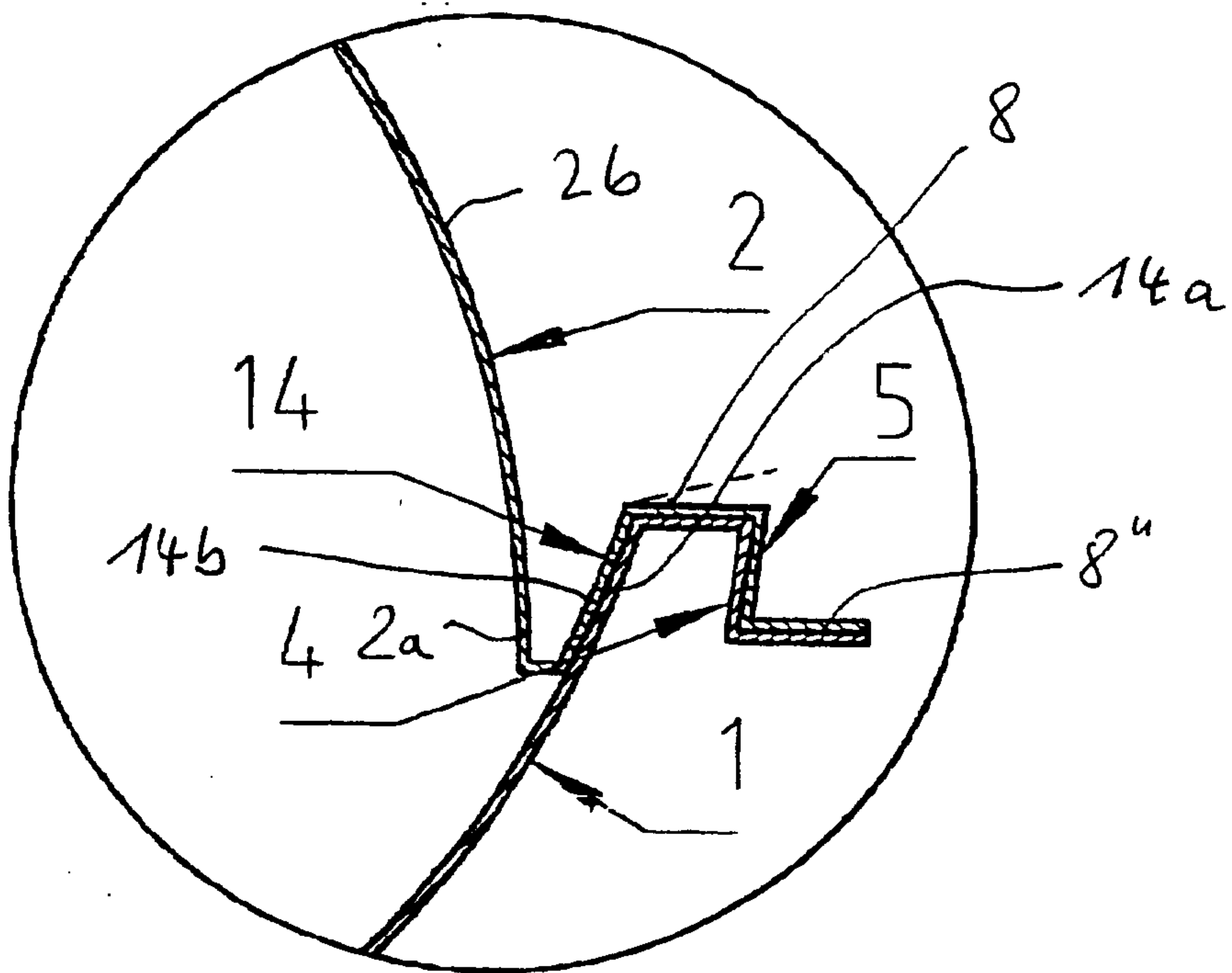

Fig. 3A

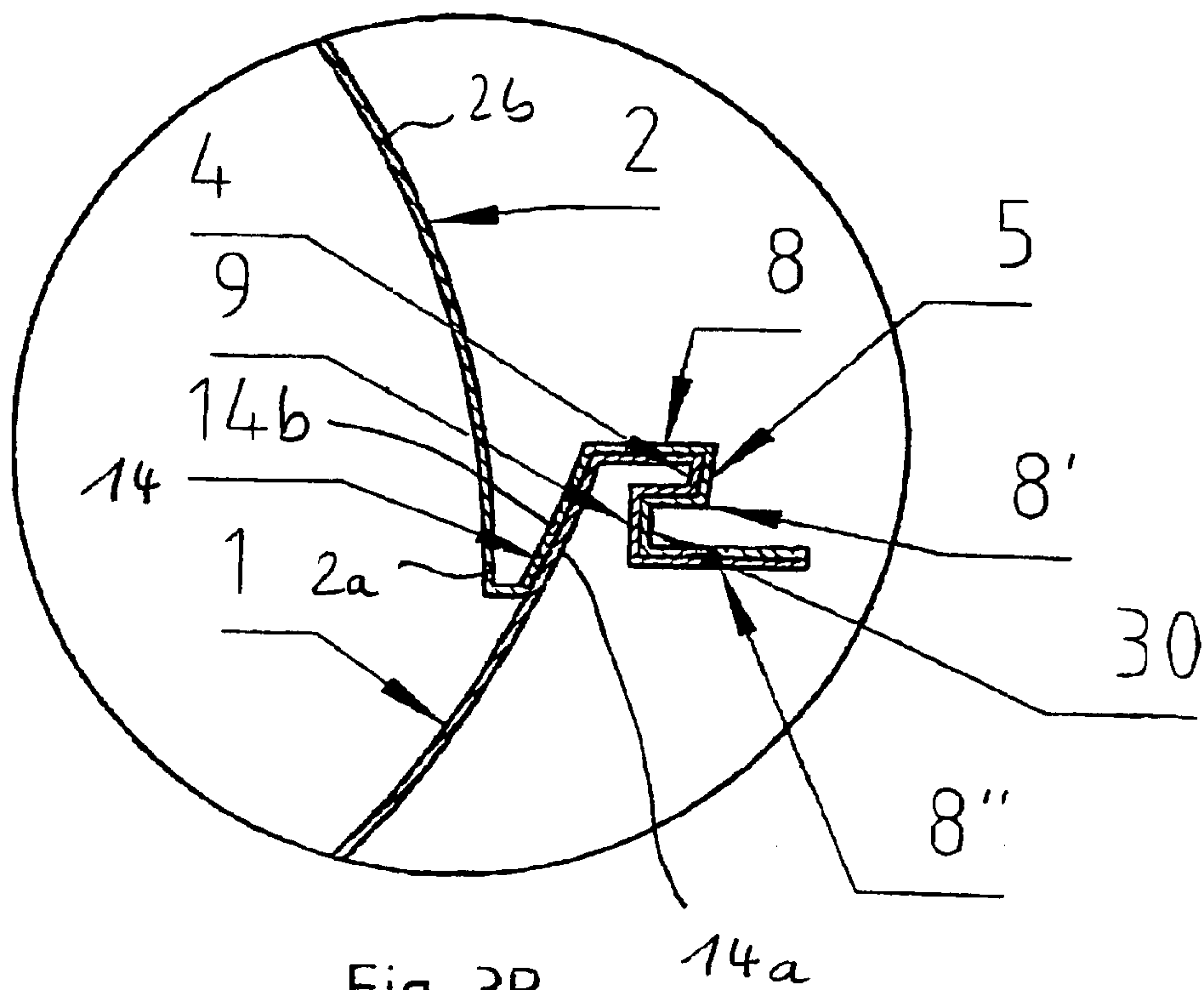

Fig. 3B

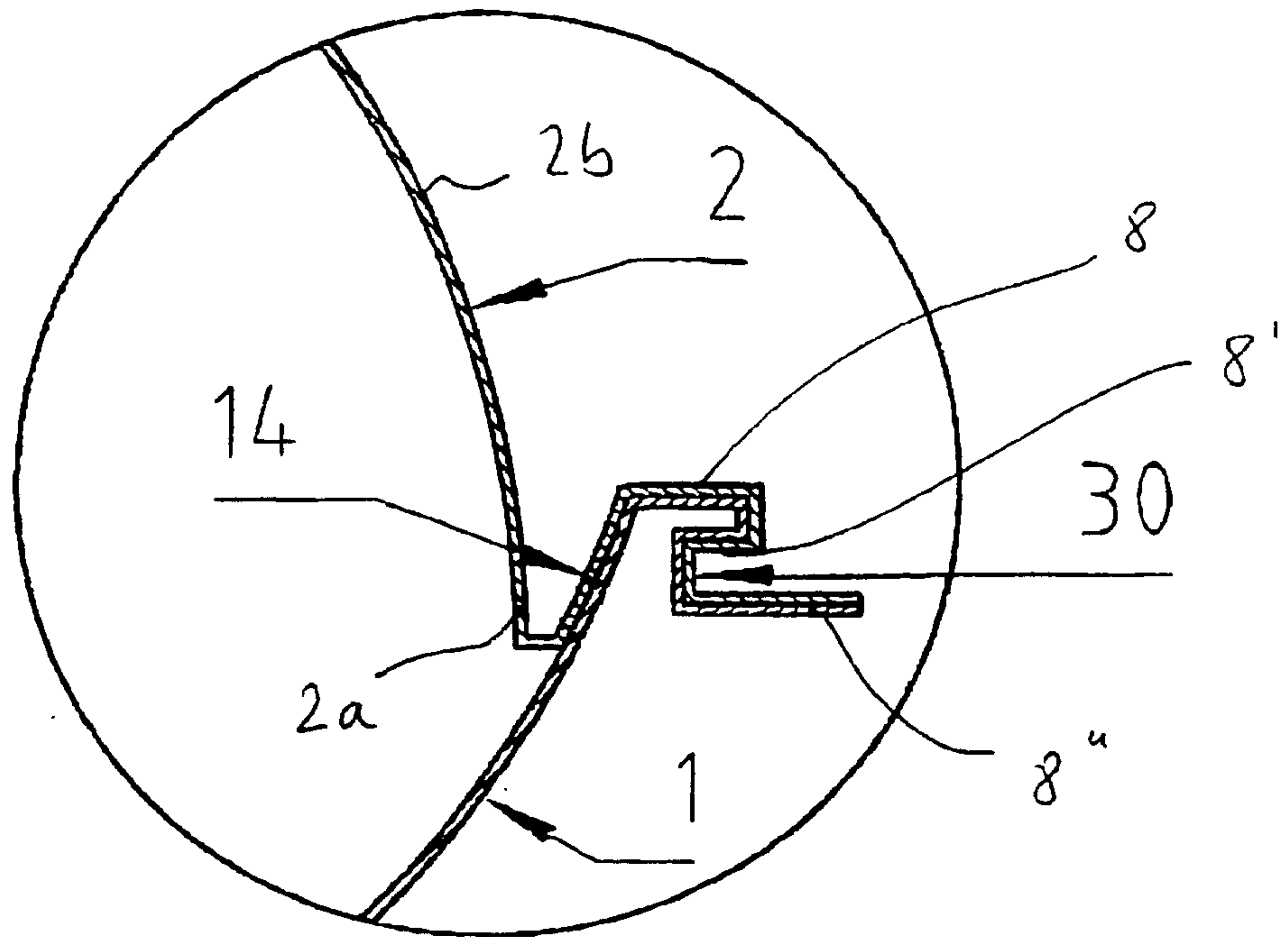

Fig. 3C

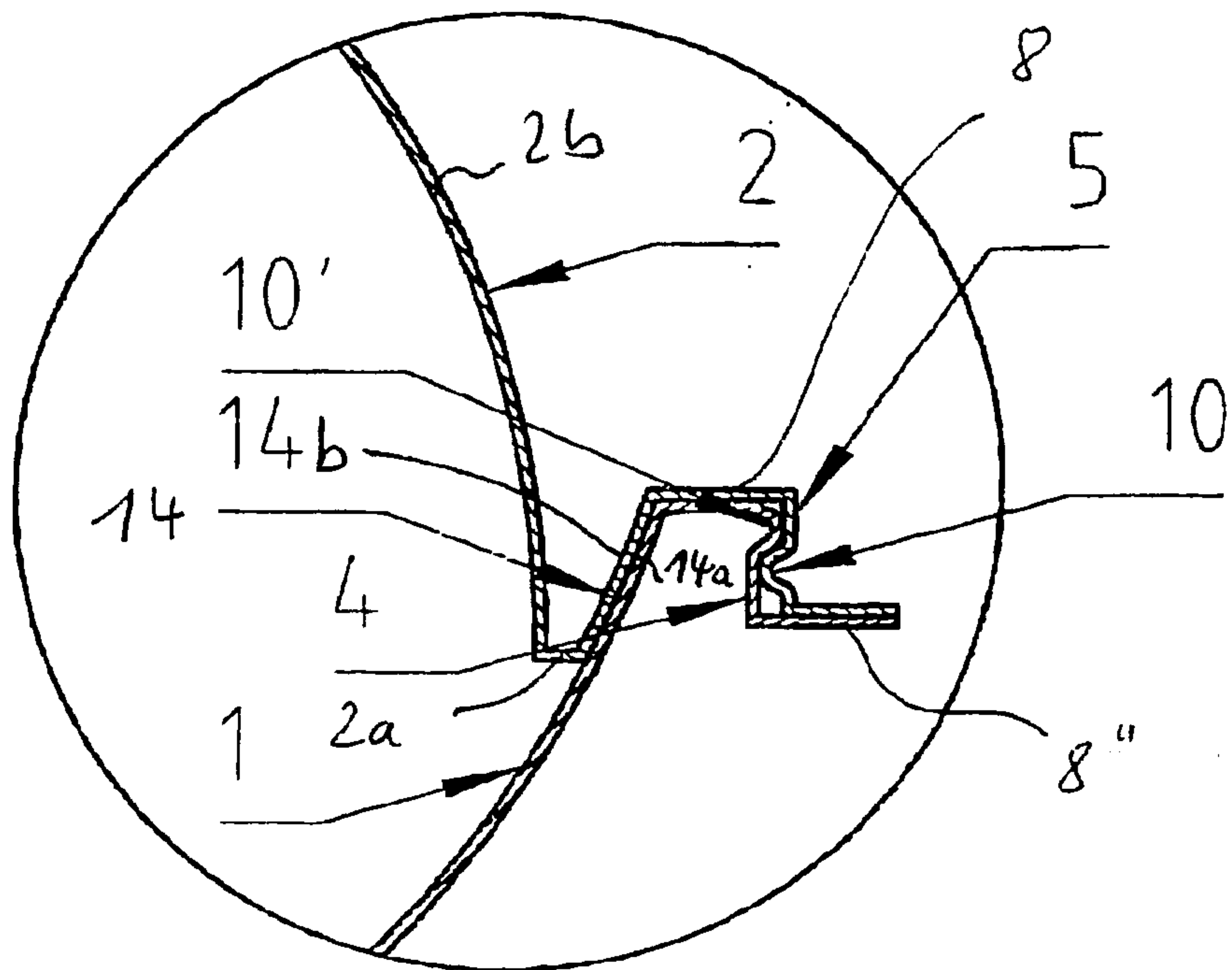

Fig. 3D

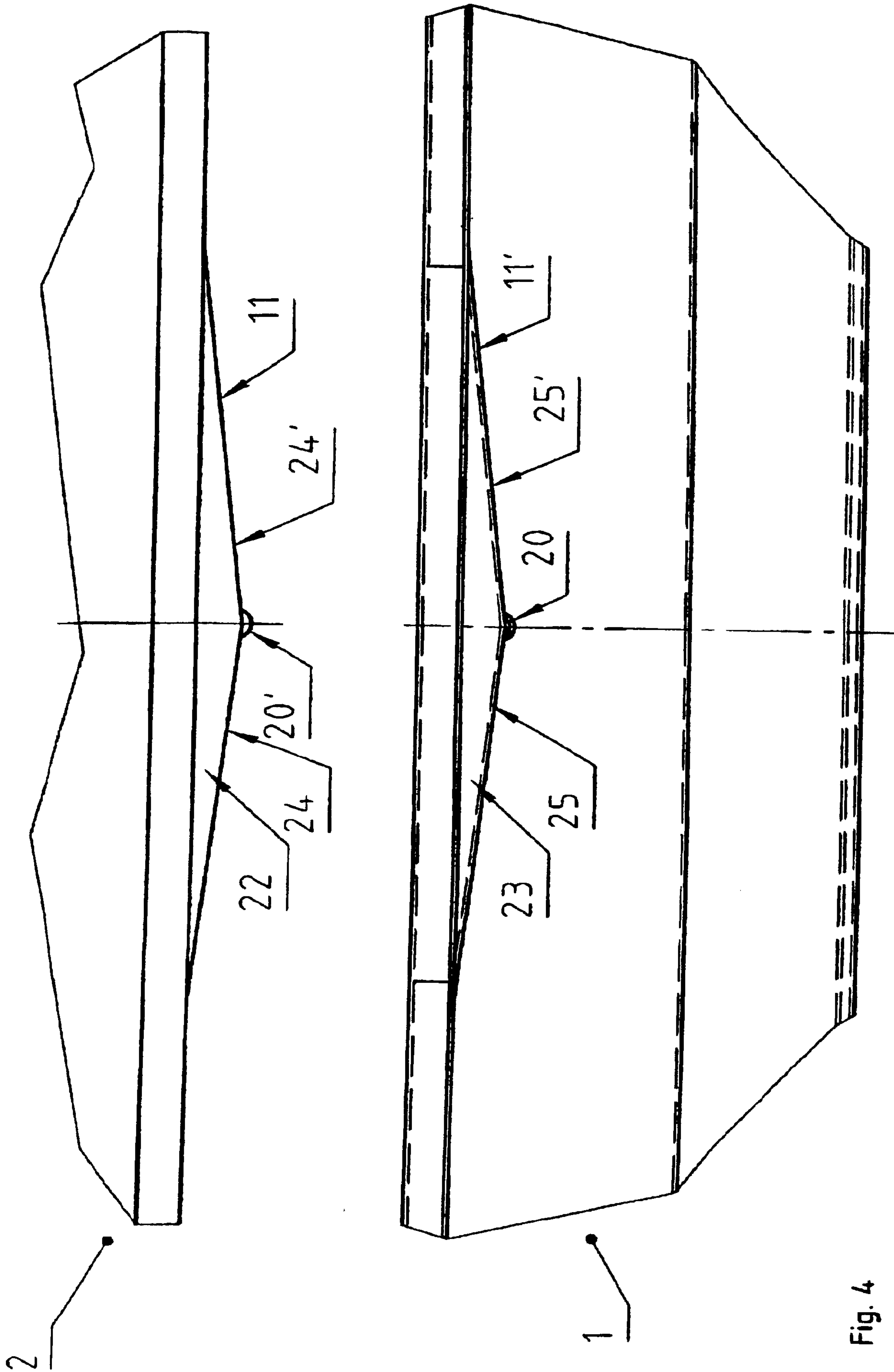

Fig. 4

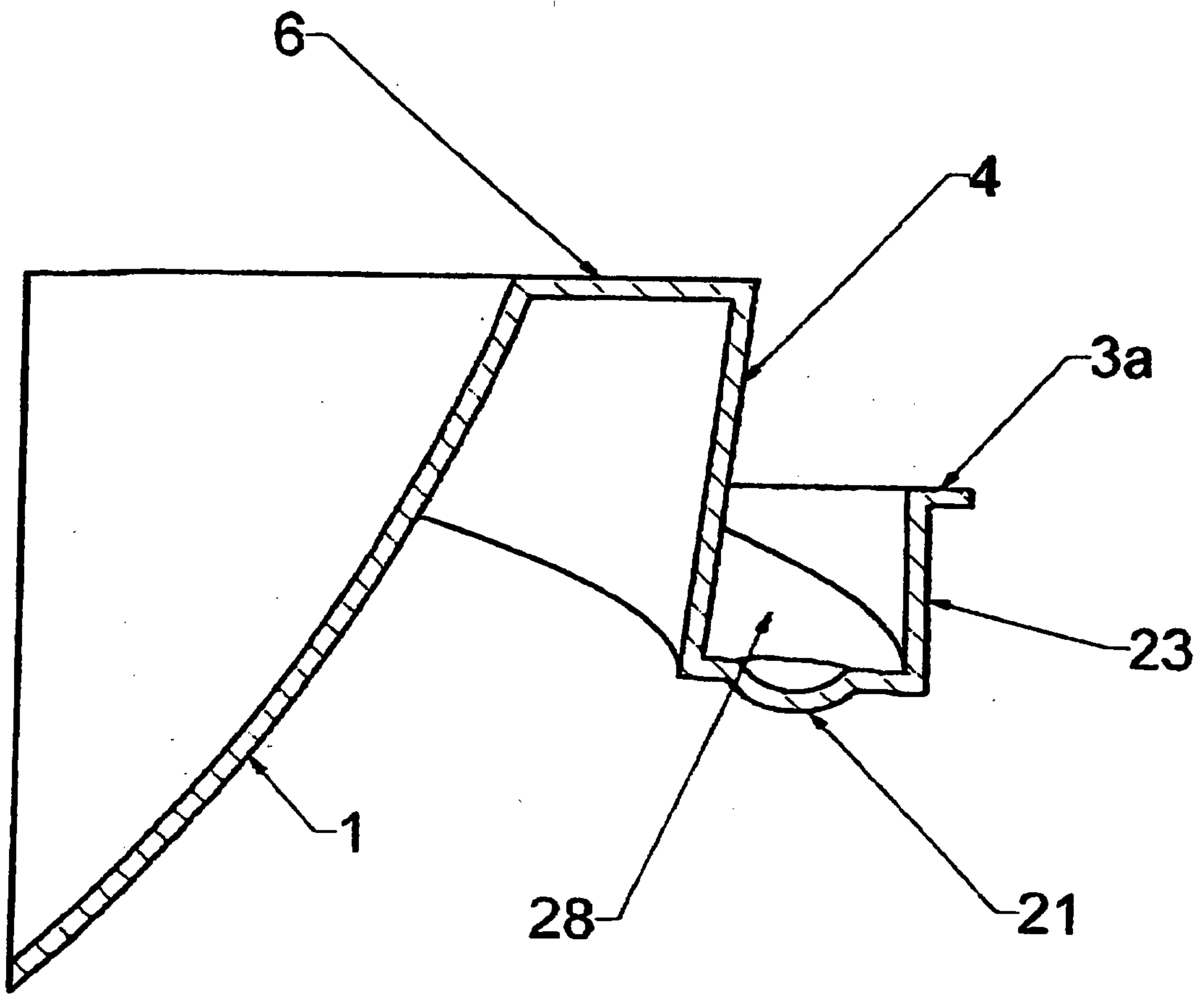

Fig.5

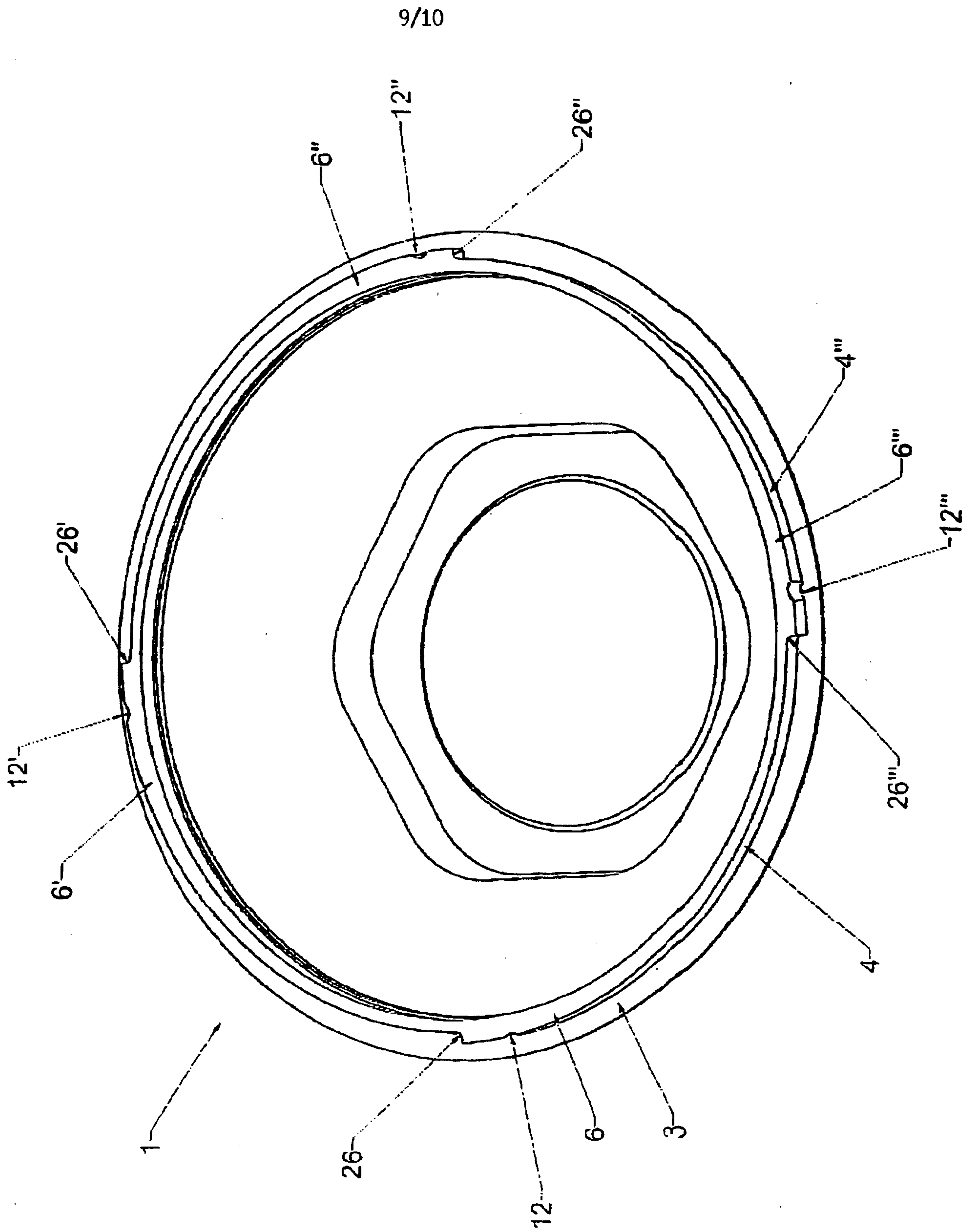

Fig. 6

10/10

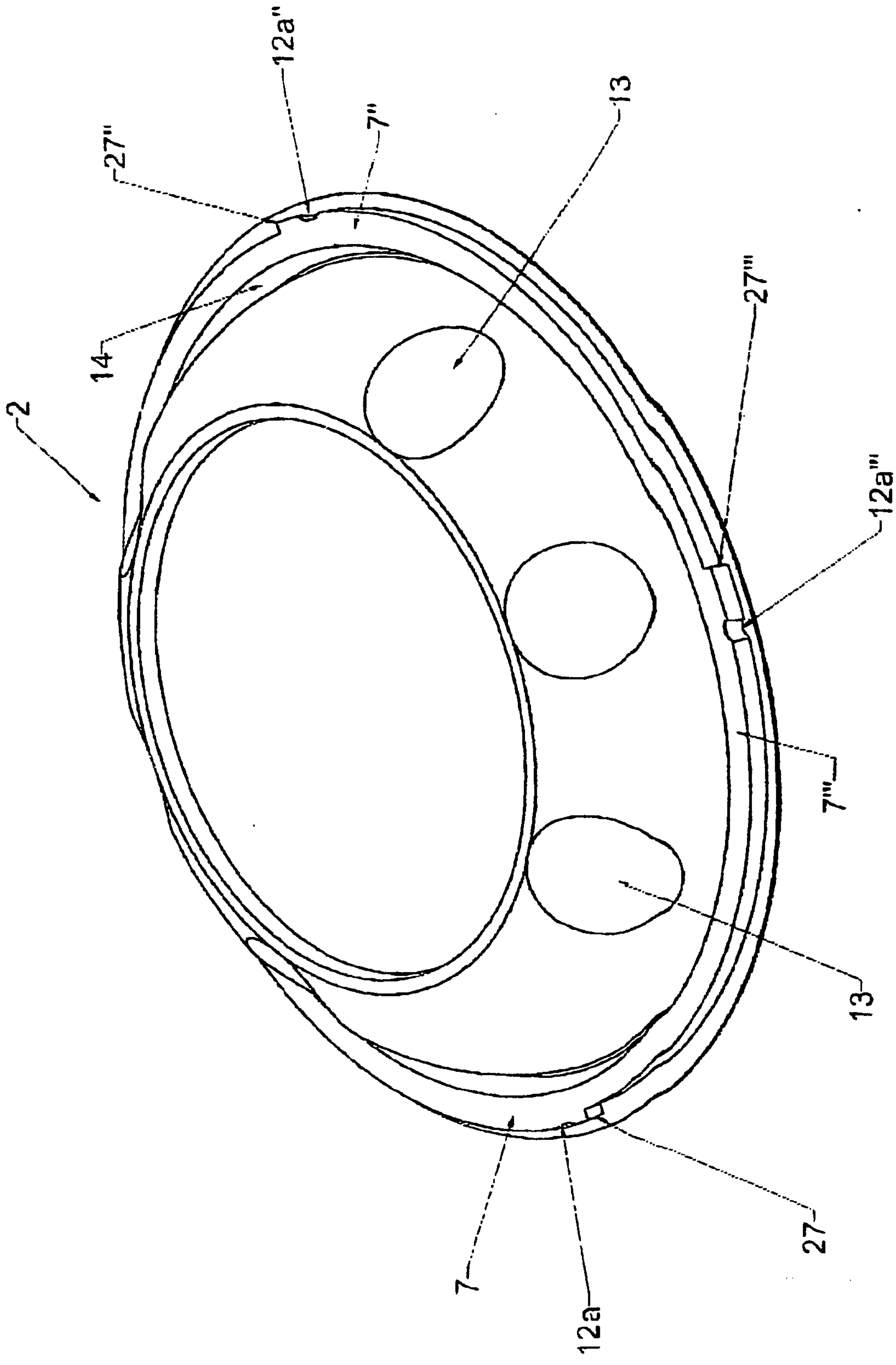

Fig.7

