

Feb. 27, 1934.

W. A. VAN BERKEL

1,948,811

SLICING MACHINE KNIFE SHARPENER

Filed Sept. 23, 1932

2 Sheets-Sheet 1

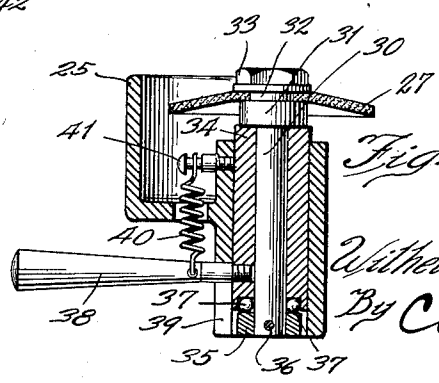
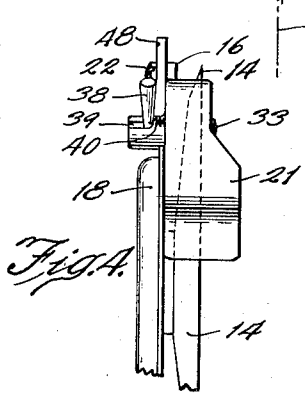
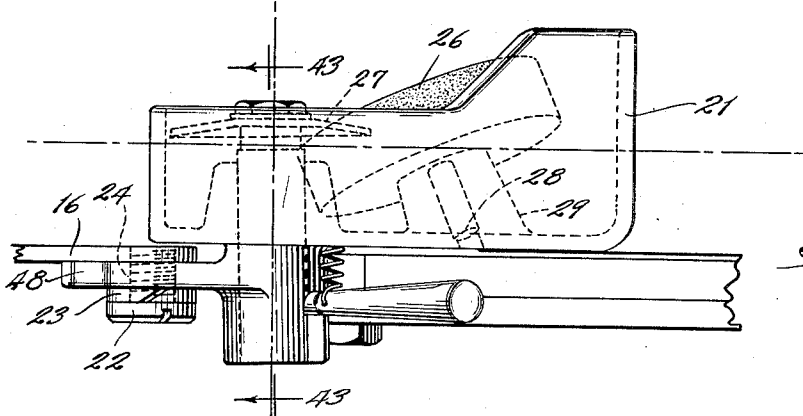
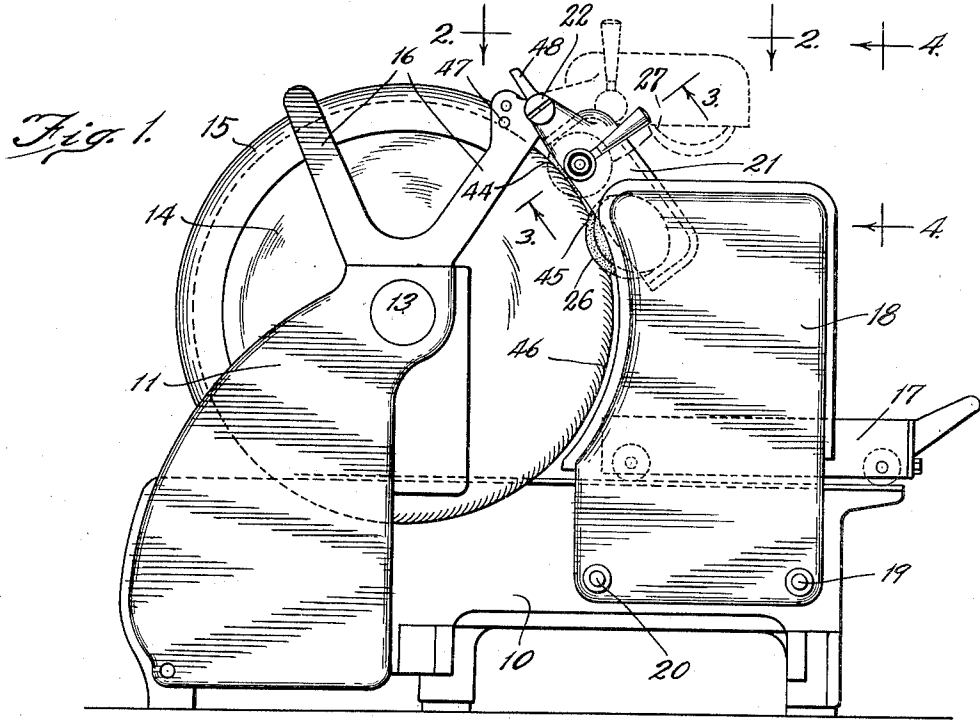

Fig. 2.

Fig. 3.
Inventor:
Wilhelmus A. van Berkel
By Cox + Moore
Attys

Feb. 27, 1934.

W. A. VAN BERKEL

1,948,811

SLICING MACHINE KNIFE SHARPENER

Filed Sept. 23, 1932

2 Sheets-Sheet 2

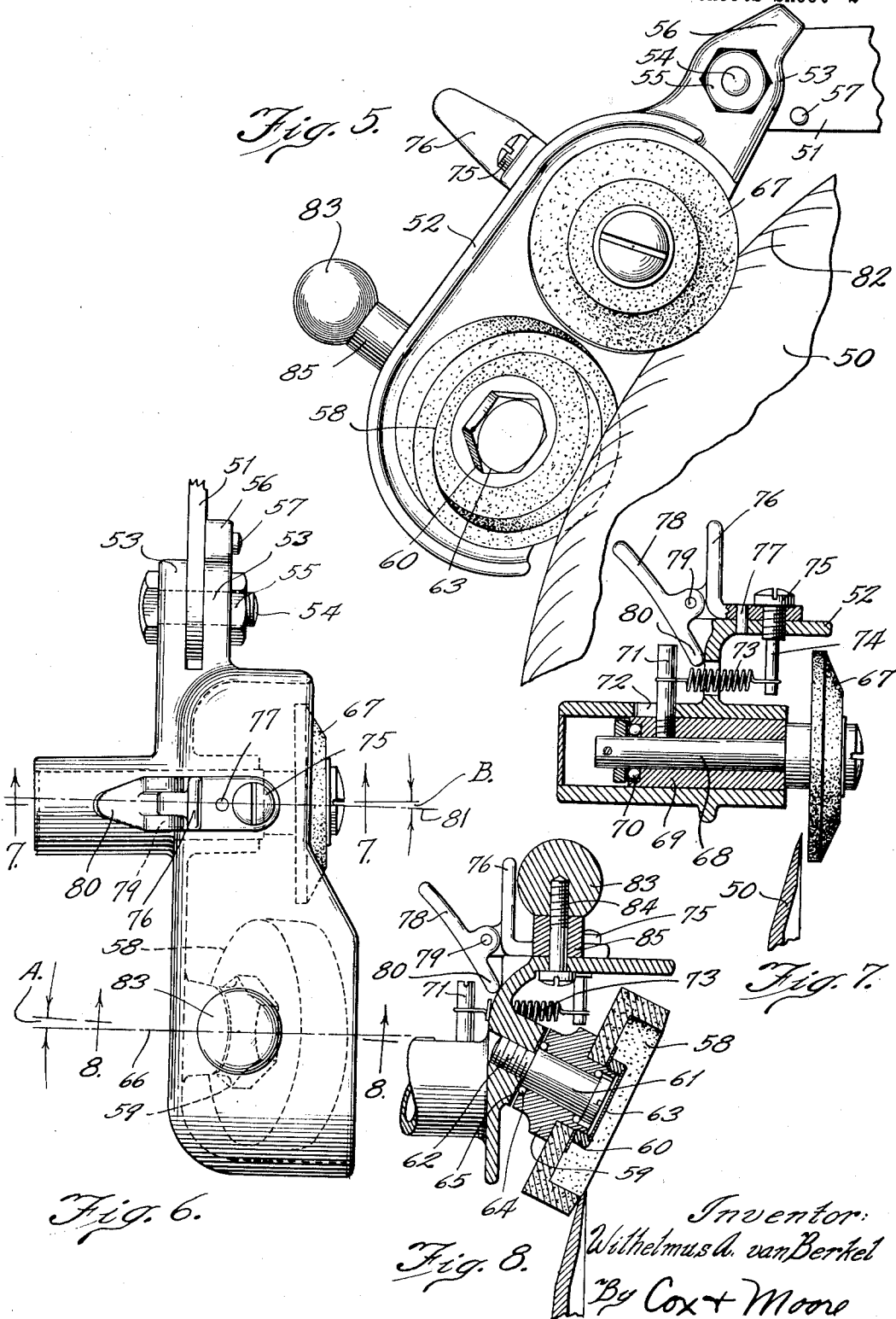

Inventor:
Wilhelmus A. van Berkel
By Cox + Moore
Attys.

UNITED STATES PATENT OFFICE

1,948,811

SLICING MACHINE KNIFE SHARPENER

Wilhelmus Adrianus van Berkel, Clarens, Switzerland; assignor to U. S. Slicing Machine Company, La Porte, Ind., a corporation of Indiana.

Application September 23, 1932, Serial No. 634,482
In Great Britain October 13, 1931

18 Claims. (Cl. 51—248)

This invention relates to slicing machines and preferably to that type of slicing machine which includes a circular knife.

The primary object of this invention is to provide means whereby the knife may be sharpened effectively by means of a sharpener which has a very simple but effective mounting.

Another object of this invention is to provide means whereby the sharpener and the guard over the sharpener act also as means for guarding the knife.

Another object of this invention resides in the provision of a friction pivot for the sharpener to permit the sharpener to be moved into and out of operative position quickly and to maintain the sharpener in operative or inoperative position.

A still further object of this invention resides in the provision of means for steadying the sharpener during the sharpening operation.

Other objects of this invention will appear hereinafter as the description thereof proceeds, the novel features, arrangements, and combinations, being clearly set forth in the appended claims.

In the drawings:

Fig. 1 represents a side elevational view of a slicing machine embodying my invention;

Fig. 2 is a plan view of the sharpening mechanism shown in Fig. 1, looking in the direction of the arrows 2—2 of Fig. 1;

Fig. 3 is a cross-section taken substantially along the line 3—3 of Fig. 1;

Fig. 4 is a view looking in the direction 4—4 of Fig. 1;

Fig. 5 is a side elevational view of a modified form of sharpener as viewed from the opposite side of the slicing machine to that shown for the sharpener in Fig. 1;

Fig. 6 is a plan view of the sharpener shown in Fig. 5, when in inoperative position;

Fig. 7 is a section taken on the line 7—7 of Fig. 6; and

Fig. 8 is a section taken on the line 8—8 of Fig. 6.

Referring now to the drawings, (Fig. 1) the reference numeral 10 represents the base of a slicing machine provided with a knife supporting bracket 11 which rotatably supports the knife shaft 13, the latter carrying the rotatable circular knife 14 guarded at the left hand and upper portions thereof by means of the circular guard 15 carried by arms 16 secured to the upper side of the bracket 11. The base supports a reciprocating table 17 upon which the substance to be sliced is placed and the material placed on this

carriage is adapted to be moved toward the cutting plane of the knife either by manual pressure or by a means which continuously feeds the substance in a direction towards the cutting plane of the knife. A gauge plate 18 is provided with a shaft 19 which shaft is slidable in the base and adjustable longitudinally of the axis of the shaft 19 to gauge the distance which the face of the gauge plate 18 is away from the cutting plane of the knife, whereby the thickness of the slices is determined in a manner which is well known in the art to which this invention pertains. A pin 20 is also associated with the gauge plate 18 to prevent turning of the gauge plate and to assist the guiding of the plate 18 as it is adjusted to and from the cutting plane of the knife.

One of the arms 16 has pivoted thereto a casing 21. This casing, as is best illustrated in Fig. 2, is mounted on a pivot screw 22 screwed into the arm 16 and provided with a lock washer 23 extending through an opening in the lug 24 on the casing 21. The lock washer not only holds the screw 22 in adjusted position, but also acts as a friction means whereby the casing for the grinding elements may be held in adjusted position about its pivot.

Rotatably mounted on the casing are a pair of sharpening elements. One of these elements is designated by the reference numeral 26 and is the main grinder, and the other is the burr removing disk 27. The main grinder 26 has a shaft 28 rotatably mounted in the bearing 29 and prevented from separation therefrom in any suitable manner as in the modification shown in Fig. 8, and to be hereinafter more particularly described. The mounting for the burr removing element 27 is best illustrated in Fig. 3 in which the reference numeral 30 represents a shaft having a collar 31 and a reduced portion 32 on which the disk is mounted and secured in place thereon by means of a nut 33 threaded to the end of the shaft 30. The shaft 30 is rotatably mounted within a sleeve 34 and is prevented from separation therefrom by means of the collar 35 secured thereto by means of a pin 36. Interposed between the collar 35 and sleeve 34 are anti-friction rollers 37 which take the end thrust on the shaft 30 caused by the sharpening action of the burr removing element.

To the sleeve 34 there is secured a handle 38 operating within a slot 39 and yieldingly urged in an upward direction as viewed in Fig. 3 by means of a spring 40 secured to the handle 38 at one end and to a stud 41 at the other, the stud being screw threaded into the casing 21.

In Fig. 2, the reference character 42 represents a line perpendicular to the cutting plane of the knife and the line 43—43 represents a line through the axis of rotation of the shaft 30. It will be noted that the axis of rotation of the shaft 30 is tilted slightly in a counter-clockwise direction from the line 42 so that the left hand side of the burr removing element will have its left side contact with the knife as viewed in Fig. 2 or there will be a contact between the sharpener and knife at the point 44 as shown in Fig. 1. Similarly the grinding element 26 will contact with the knife at 45.

When it is desired to sharpen the knife, the casing 21 is moved to the full line position shown in Fig. 1 to bring the main grinders 26 into contact with the knife. As the knife rotates, the grinder 26 also rotates by its engagement with the knife. Due to the fact that the knife is traveling at a higher rate of speed than the grinding element 26 the particles of abrasive of the grinding element drag over the surface of the knife with which the grinder is in contact, thereby producing a series of fine lines or scratches in the direction illustrated at 46 in Fig. 1, the lines being greatly exaggerated for the purpose of illustration. Similarly, the hardened particles of the burr removing element 27 move in a direction to produce similar scratches on the opposite side of the knife thereby producing in effect a knife with small saw-like teeth at the peripheral edge thereof. While these teeth are relatively small, at the same time, the effect of making all of the scratches extend in the same direction is novel and produces a cutting edge which is very highly desirable. The burr removing grinder is maintained in engagement with the knife until the desired amount of the knife is ground away and thereafter by manually moving the handle 38, the burr removing element is moved into engagement with the knife and removes the burr formed on the edge of the knife while at the same time producing the fine scratches on the edge of the knife already described. The action of the burr removing element is more pronounced when an abrasive stone is used as is shown in the modification of the invention in Figs. 5 to 8 inclusive.

Whenever a relatively deep cut is to be taken by the grinding element 26, and it is desired to grind the edge of the knife in a true plane, I move the gauge plate 18 toward the cutting plane of the knife until it engages the casing 21 as is best illustrated in Fig. 4. This prevents any lateral movement of the grinding element away from the cutting plane of the knife and a true bevel is ground on the edge of the knife.

The casing 21 is prevented from moving beyond the dotted line position shown in Fig. 1 by a stop 47 engaging the outwardly extending lug 48 on the casing 21.

In Figs. 5, 6, 7, and 8, I have shown a slight modification of my invention in which 50 represents the knife and 51 an arm corresponding to the arm 16 shown in Fig. 1. The casing 52 is mounted similarly to that in Figs. 1 to 4 inclusive except that it has a pair of lugs 53 straddling the arm 51 and has a bolt 54 locked in place by a nut 55, the resiliency of the lugs 53 and the pressure of the nut 55 and bolt 54 causing a gripping of the arm 51 so as to maintain the casing in adjusted position by means of friction. A lug 56 engages with a stop 57 similar to the stop 47 in Fig. 1. The main grinding element 58 is secured between a shoulder

on the sleeve 59 and a nut 60, the sleeve in turn being mounted to rotate on a short stub shaft 61 threaded into the casing 62 and provided with a cover plate 63 to prevent the accumulation of foreign material on the threads of the nut 60 and the head of the stub shaft 61. Anti-friction bearings 64 are interposed between the sleeve 59 and a hardened steel race 65 whereby an efficient bearing is provided for taking the end thrust on the grinder 58.

The grinding element 58 is tilted at a decided angle to the horizontal looking at it in the direction illustrated in Fig. 3, and is also inclined slightly away from a line 66 which indicates a line perpendicular to the cutting plane of the knife. The angular difference between the axis of rotation of the grinding element 58 and the line 66 in a horizontal direction is indicated by the angle A in Fig. 6.

The burr removing element 67 illustrated in Fig. 7 is mounted similarly to the burr removing grinder in Figs. 1 to 4 inclusive, the same being carried by a shaft 68 rotatably mounted on a shaft 69 provided with anti-friction bearings 70. A screw 71 is threaded into the sleeve and operates in the slot 72. A spring 73 is connected to the screw 71 at one end and to an extension 74 of the screw 75 at the other to normally hold the burr removing element in the position shown in Fig. 7. The screw 75 also acts as a means whereby the angle piece 76 is held in place on the casing 52, a pin 77 on the casing acting as a means to prevent rotation of the angle piece 76 about the screw 75. A lever 78 pivoted at 79 to the angle piece 76 has the lower projection 80 thereon arranged in a position to engage the screw 71 and move it to the left when the upper end of the lever 78 is moved toward the angle piece 76 whereby the burr removing element 67 is moved into engagement with the knife 50. The shaft 68 is displaced angularly through an angle B from the line 81 which illustrates a line perpendicular to the cutting plane of the knife. The arrangement is the same as for the sharpening element 27 shown in Fig. 2. The lines formed by the burr removing element 67 are indicated at 82 in Fig. 5.

The casing is provided with an operating handle 83 secured to the casing by a screw 84 and spaced therefrom by means of a sleeve 85 surrounding the screw 84. This operating knob 83 is used for moving the sharpener to and from its operative position.

Obviously those skilled in the art to which this invention pertains may make various changes in the construction and arrangement of parts without departing from the spirit of this invention, and therefore I do not wish to be limited except as hereinafter set forth in the appended claims.

Having thus fully described my invention, what I claim as new and desire to obtain by Letters Patent is:

1. In a slicing machine, the combination with a slicing knife, of a gauge plate, a carriage movable past said knife to carry the substance into engagement with the knife for slicing purposes, and a sharpener associated with said knife adapted to be moved into and out of sharpening association with said knife, said sharpener while in sharpening association with said knife being in operative position between the edge of said knife and said gauge plate whereby said gauge plate can be moved into engagement with said sharpener to form a rigid backing therefor during the

sharpening operation to prevent movement of said sharpener away from said knife.

2. In a slicing machine, the combination with a slicing knife and table reciprocable relative to each other, a sharpener for sharpening said knife, and a rigidly guided gauge plate for gauging the thickness of the slices to be cut and movable to and from the cutting plane of said knife and against said sharpener when said sharpener is in operative sharpening position to hold said sharpener against movement away from the cutting plane of said knife.

3. In a slicing machine, the combination with a slicing knife and table reciprocable relative to each other, a sharpener for sharpening said knife, and a rigidly guided gauge plate for gauging the thickness of the slices to be cut and movable to and from the cutting plane of said knife and against said sharpener when said sharpener is in operative sharpening position to hold said sharpener against movement away from the cutting plane of said knife, said sharpener being pivotally mounted adjacent said knife edge and having a friction pivot about which the same moves when moved to and from sharpening position whereby said sharpener is held in any adjusted position about its pivot to which the same is moved.

4. In a slicing machine, the combination with a slicing knife and table reciprocable relative to each other, a sharpener for sharpening said knife, and a rigidly guided gauge plate for gauging the thickness of the slices to be cut movable to and from the cutting plane of said knife and against said sharpener when said sharpener is in operative sharpening position to hold said sharpener against movement away from the cutting plane of said knife, said slicing knife having a knife guard over the top and rear portions thereof and said sharpener being pivoted to said guard about an axis substantially perpendicular to the cutting plane of said knife so that said sharpener swings substantially in the plane of said knife to and from sharpening position, said pivot having friction means associated therewith to resist movement of said sharpener about its pivot and to hold said sharpener in adjusted position about its pivot.

5. In a sharpener for slicing machines, the combination with a casing adapted to be pivotally mounted adjacent the cutting plane of the knife on an axis which extends substantially perpendicular to the cutting plane of the knife, a main sharpening element inclined toward the cutting plane of the knife in two directions having an axis of rotation extending generally in the same direction as the pivot and the inclinations of the sharpening element being in a direction to impart the desired bevel to the knife, and in a direction to bring one edge only of the flat side thereof into engagement with the knife edge, and to hold the opposite edge of the same surface away from the knife during the sharpening operation, a rotatable burr removing grinder having its axis extending generally parallel with the pivot for the casing but inclined slightly in a direction toward the pivot and cutting plane to bring one side of the flat face of said burr removing element into engagement with the knife, the respective portions of the sharpening element and burr removing element which contact with the knife being arranged on the same sides of their respective axes of rotation in the direction of knife movement and being those sides which are first presented to the knife during

its movement, and a gauge plate movable to and from the cutting plane of said knife for engaging said casing to prevent retrograde movement thereof and of said sharpening element away from the cutting plane of said knife.

6. In a slicing machine, the combination with a rotary slicing knife, of a sharpener for said knife comprising a sharpener support having a fixed position with respect to the axis of rotation of said knife, a member movably mounted on said support for movement substantially parallel to the cutting plane of said knife and restrained against movement other than in said direction, continuously acting friction means of appreciable amount for holding said member in adjusted position, and a sharpening element on said member for engaging one side of said knife adjacent the edge thereof when said member is moved toward said knife, said friction means acting to resist pressure of said sharpener against said knife when manual pressure is applied to said member.

7. In a slicing machine, the combination with a rotary slicing knife, of a sharpener for said knife comprising a sharpener support having a fixed position with respect to the axis of rotation of said knife, a member movably mounted on said support for movement substantially parallel to the cutting plane of said knife and restrained against movement other than in said direction, continuously acting friction means of appreciable amount for holding said member in adjusted position, a sharpening element on said member for engaging one side of said knife adjacent the edge thereof when said member is moved toward said knife, said friction means acting to resist pressure of said sharpener against said knife when manual pressure is applied to said member, and an additional sharpening element movably mounted on said member for movement against said knife to remove the burr formed by said first sharpening element.

8. In a slicing machine, the combination with a rotary slicing knife, of a sharpener for said knife comprising a sharpener support having a fixed position with respect to the axis of rotation of said knife, a member movably mounted on said support for movement substantially parallel to the cutting plane of said knife and restrained against movement other than in said direction, continuously acting friction means of appreciable amount for holding said member in adjusted position, a sharpening element on said member for engaging one side of said knife adjacent the edge thereof when said member is moved toward said knife, said friction means acting to resist pressure of said sharpener against said knife when manual pressure is applied to said member, and an additional sharpening element slidably guided on said member for movement to and from the slicing knife for removing the burr formed on said knife by said first sharpening element.

9. In a slicing machine, the combination with a rotary slicing knife, of a sharpener for said knife comprising a sharpener support having a fixed position with respect to the axis of rotation of said knife, a member movably mounted on said support for movement substantially parallel to the cutting plane of said knife and restrained against movement other than in said direction, continuously acting friction means of appreciable amount for holding said member in adjusted position, a sharpening element on said member for engaging one side of said knife adjacent the edge thereof when said member is moved toward said

knife, said friction means acting to resist pressure of said sharpener against said knife when manual pressure is applied to said member, and a rigid abutment in position to engage said casing when said sharpening element is against the side of said knife and being located at the side of said sharpening element away from said knife to act as a means for preventing movement of said sharpener away from said knife.

10. In a slicing machine, the combination with a rotary slicing knife, of a sharpener for said knife comprising a sharpener support having a fixed position with respect to the axis of rotation of said knife, a member movably mounted on said support for movement substantially parallel to the cutting plane of said knife and restrained against movement other than in said direction, continuously acting friction means of appreciable amount for holding said member in adjusted position, a sharpening element on said member for engaging one side of said knife adjacent the edge thereof when said member is moved toward said knife, said friction means acting to resist pressure of said sharpener against said knife when manual pressure is applied to said member, and a gauge plate movably mounted for movement to and from the cutting plane thereof having means thereon for engaging the said member when in operative position to prevent movement of said sharpening element away from said knife.

11. In a slicing machine, the combination with a rotary slicing knife, of a sharpener for said knife comprising a sharpener support having a fixed position with respect to the axis of rotation of said knife, a member pivoted at one end thereof to said support for pivotal movement substantially parallel to the cutting plane of said knife and restrained against movement other than in said direction, continuously acting friction means of appreciable amount for holding said member in adjusted position about its pivot, and a sharpening element on said member for engaging one side of said knife adjacent the edge thereof when said member is moved toward said knife, said friction means acting to torsionally resist pressure of said sharpener against said knife when manual pressure is applied to said member in a direction to bring said sharpener against said knife, whereby the pressure of said sharpener against said knife may be controlled.

12. In a slicing machine, the combination with a slicing knife, of a sharpener member mounted for movement in a direction parallel to the cutting plane of said knife, a sharpening element on said member, and a rigid backing member operative when said element is in engagement with said knife for engaging said sharpener member to prevent movement of said element and said first mentioned member away from said knife, said backing member being at a position substantially in alignment with the line of direct thrust on said sharpening element by said knife.

13. In a slicing machine, the combination with a knife support, of a knife rotatably mounted on said support, a sharpener pivoted to said support about an axis substantially perpendicular to the cutting plane of said knife, a sharpening element on said sharpener eccentrically mounted thereon with respect to the pivotal axis of said sharpener, whereby said sharpening element may be brought into engagement with the cutting edge of said knife by pivotal movement of said sharpener about its pivotal connection with said support, restraining means for resisting movement of said sharpener toward the cutting edge of said

knife, means for engaging said sharpener at a point substantially directly opposed to the position at which said sharpening element engages the knife to prevent movement of said sharpening element bodily in a direction perpendicular to the cutting plane of said knife, a limiting stop for limiting the movement of said sharpener away from the cutting edge of said knife, said sharpener being free to move toward said knife in the direction of the plane thereof and remain in engagement with said knife as the sharpening element removes portions of said knife and decreases the diameter thereof, whereby adjustment of said sharpening element bodily in a direction toward and from the cutting plane of said knife is eliminated.

14. A device as set forth in claim 13 in which the means for preventing bodily movement of said element away from said knife comprises a gauge plate movable through successive positions parallel to the cutting plane of said knife and having a portion thereof adapted to engage said sharpener at a position remote from its point of pivotal connection with said support for preventing movement of said sharpener away from the cutting plane of said knife.

15. In a slicing machine, the combination with a slicing knife, of a support, a carrier having a sharpening element thereon and having a connection with said support such that said carrier may be moved relative to said support to and from said knife substantially in the plane of said knife, to bring said sharpening element into engagement with said knife, and a rigid backing member for engaging said carrier on the side thereof away from said knife, at a point substantially in direct opposition to the position at which said knife and sharpening element engage to prevent yielding movement of said carrier and element away from said knife.

16. In a slicing machine, the combination with a slicing knife, of a support, a carrier having a sharpening element thereon and having a connection with said support such that said carrier may be moved relative to said support to and from said knife substantially in the plane of said knife, to bring said sharpening element into engagement with said knife, and a rigid backing member for engaging said carrier on the side thereof away from said knife, at a point substantially in direct opposition to the position at which said knife and sharpening element engage to prevent yielding movement of said carrier and element away from said knife, said rigid backing member being mounted for adjustment to and from the cutting plane of said knife, whereby the pressure of said sharpener against the knife may be varied.

17. In a slicing machine, the combination with a slicing knife, of a sharpener pivoted on an axis substantially perpendicular to the cutting plane of said knife, guard means for guarding the peripheral cutting edge of said knife, except at the cutting position thereof, said sharpener being pivoted adjacent said unguarded portion of said knife for pivotal movement to an operative position over the edge of said knife, with the sharpening portion thereof in engagement with said knife, a gauge plate having the operative surface thereof arranged substantially parallel to the cutting plane of said knife, and mounted for movement toward and from the cutting plane thereof into the path of movement of said sharpener, whereby when said gauge plate is in some

of its positions, said sharpener cannot be moved into engagement with said knife, said gauge plate having a position, however, in which it is outside of the path of movement of said sharpener, whereby said sharpener may be moved freely about its pivot into engagement with the knife, and the gauge plate thereafter moved against said sharpener to prevent movement of said sharpener away from said knife, in a direction perpendicular to the cutting plane thereof.

18. In a slicing machine, the combination with a slicing knife, of a sharpener support, a sharpener carrier having a sharpening element carried thereby, a connection between said

carrier and support such that the sharpening element may be moved in a plane substantially parallel with the cutting plane of said knife into and out of engagement therewith, said connection being located substantially to one side of the line of direct thrust on said sharpening element during the sharpening operation, and means engaging said carrier on the opposite side of said line of direct thrust, remote from said connection to prevent springing of said carrier and sharpening element away from said knife during sharpening thereof.

WILHELMUS ADRIANUS VAN BERKEL.

15	80
20	85
25	90
30	95
35	100
40	105
45	110
50	115
55	120
60	125
65	130
70	135
75	140
	145
	150