

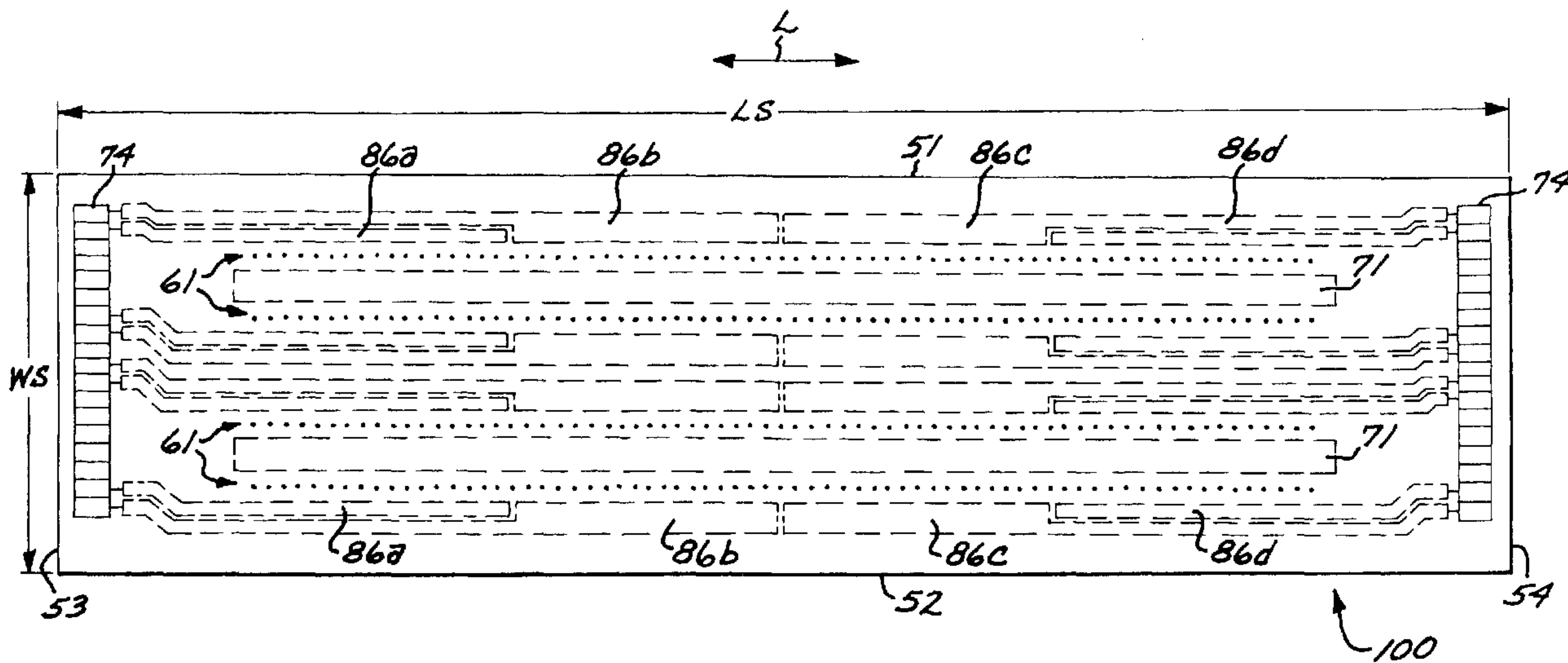

(86) Date de dépôt PCT/PCT Filing Date: 2001/09/07
 (87) Date publication PCT/PCT Publication Date: 2002/08/08
 (85) Entrée phase nationale/National Entry: 2003/01/28
 (86) N° demande PCT/PCT Application No.: US 2001/028081
 (87) N° publication PCT/PCT Publication No.: 2002/060696
 (30) Priorité/Priority: 2001/01/30 (09/773,182) US

(51) Cl.Int.⁷/Int.Cl.⁷ B41J 2/15
 (71) Demandeur/Applicant:
HEWLETT-PACKARD COMPANY, US
 (72) Inventeurs/Inventors:
TORGERSON, JOSEPH M., US;
BROWNING, ROBERT N. K., US;
MACKENZIE, MARK H., US;
MILLER, MICHAEL D., US;
BAKKOM, ANGELA WHITE, US;
DODD, SIMON, US
 (74) Agent: SIM & MCBURNEY

(54) Titre : TETE D'IMPRESSION A JET D'ENCRE ETROITE
 (54) Title: NARROW INK JET PRINTHEAD



(57) Abrégé/Abstract:

A narrow ink jet printhead (100) having four columnar arrays (61) of ink drop generators (40) configured for monochrome single-pass printing at a print resolution having a media axis dot spacing that is less than the columnar nozzle spacing of the ink drop generators. The ink jet printhead more particularly includes high resistance heater resistors (56) and efficient FET drive circuits (85) that are configured to compensate for variation in parasitic resistance presented by power traces (86a, 86b, 86c, 86d, 181).

(12) INTERNATIONAL APPLICATION PUBLISHED UNDER THE PATENT COOPERATION TREATY (PCT)

(19) World Intellectual Property Organization
International Bureau



(43) International Publication Date
8 August 2002 (08.08.2002)

PCT

(10) International Publication Number
WO 02/060696 A1

- (51) International Patent Classification⁷: **B41J 2/15**
- (21) International Application Number: PCT/US01/28081
- (22) International Filing Date:
7 September 2001 (07.09.2001)
- (25) Filing Language: English
- (26) Publication Language: English
- (30) Priority Data:
09/773,182 30 January 2001 (30.01.2001) US
- (71) Applicant: **HEWLETT-PACKARD COMPANY**
[US/US]; M/S 20BN, 3000 Hanover Street, Palo Alto, CA
94304-1112 (US).
- (72) Inventors: **TORGERSON, Joseph, M.**; 24901 Hidden Valley Road, Philomath, OR 97370 (US). **BROWNING, Robert, N., K.**; 1715 NW Menlo Drive, Corvallis, OR 97330 (US). **MACKENZIE, Mark, H.**; 1715 NW Menlo Drive, Corvallis, OR 97330 (US). **MILLER, Michael, D.**; 33788 Sunset View Lane, Shedd, OR 97377 (US). **BAKKOM, Angela, White**; 1645 SW Otana Drive, Corvallis, OR 97330 (US). **DODD, Simon**; 216 NE Plymouth Circle, Corvallis, OR 97330 (US).
- (74) Agents: **WISDOM, Gregg, W.** et al.; International Filing Manager, Legal Department, IP Section, Hewlett-Packard Company, PO Box 272400, Ft. Collins, CO 80527-2400 (US).
- (81) Designated States (*national*): AE, AG, AL, AM, AT, AU, AZ, BA, BB, BG, BR, BY, BZ, CA, CH, CN, CO, CR, CU, CZ, DE, DK, DM, DZ, EC, EE, ES, FI, GB, GD, GE, GH, GM, HR, HU, ID, IL, IN, IS, JP, KE, KG, KP, KR, KZ, LC, LK, LR, LS, LT, LU, LV, MA, MD, MG, MK, MN, MW, MX, MZ, NO, NZ, PH, PL, PT, RO, RU, SD, SE, SG, SI, SK, SL, TJ, TM, TR, TT, TZ, UA, UG, UZ, VN, YU, ZA, ZW.
- (84) Designated States (*regional*): European patent (AT, BE, CH, CY, DE, DK, ES, FI, FR, GB, GR, IE, IT, LU, MC, NL, PT, SE, TR).
- Published:**
— with international search report
- For two-letter codes and other abbreviations, refer to the "Guidance Notes on Codes and Abbreviations" appearing at the beginning of each regular issue of the PCT Gazette.

(54) Title: NARROW INK JET PRINTHEAD

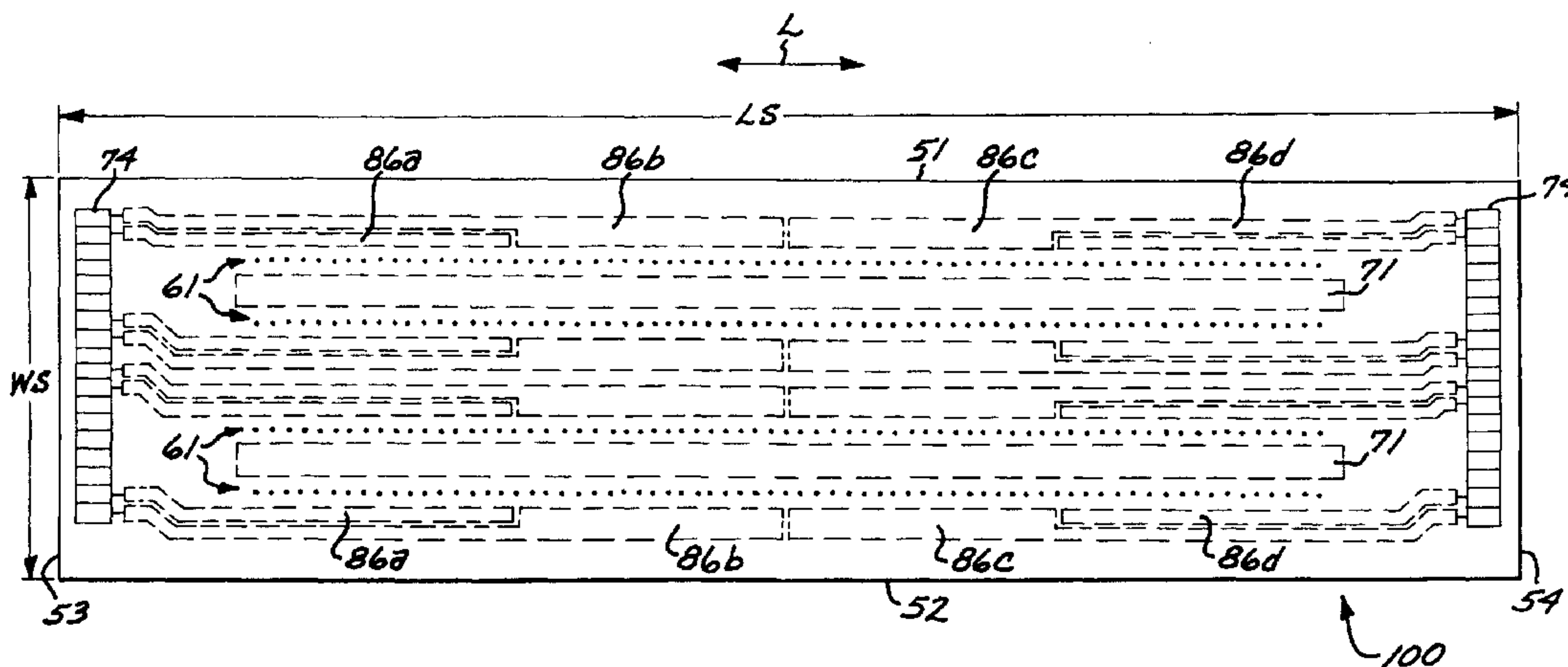

(57) Abstract: A narrow ink jet printhead (100) having four columnar arrays (61) of ink drop generators (40) configured for monochrome single-pass printing at a print resolution having a media axis dot spacing that is less than the columnar nozzle spacing of the ink drop generators. The ink jet printhead more particularly includes high resistance heater resistors (56) and efficient FET drive circuits (85) that are configured to compensate for variation in parasitic resistance presented by power traces (86a, 86b, 86c, 86d, 181).

WO 02/060696 A1

NARROW INK JET PRINTHEAD

BACKGROUND OF THE INVENTION

[0001] The subject invention generally relates to ink jet printing, and more particularly to a narrow thin film ink jet printhead.

[0002] The art of ink jet printing is relatively well developed. Commercial products such as computer printers, graphics plotters, and facsimile machines have been implemented with ink jet technology for producing printed media. The contributions of Hewlett-Packard Company to ink jet technology are described, for example, in various articles in the Hewlett-Packard Journal, Vol. 36, No. 5 (May 1985); Vol. 39, No. 5 (October 1988); Vol. 43, No. 4 (August 1992); Vol. 43, No. 6 (December 1992); and Vol. 45, No. 1 (February 1994); all incorporated herein by reference.

[0003] Generally, an ink jet image is formed pursuant to precise placement on a print medium of ink drops emitted by an ink drop generating device known as an ink jet printhead. Typically, an ink jet printhead is supported on a movable print carriage that traverses over the surface of the print medium and is controlled to eject drops of ink at

appropriate times pursuant to command of a microcomputer or other controller, wherein the timing of the application of the ink drops is intended to correspond to a pattern of pixels of the image being printed.

[0004] A typical Hewlett-Packard ink jet printhead includes an array of precisely formed nozzles in an orifice plate that is attached to an ink barrier layer which in turn is attached to a thin film substructure that implements ink firing heater resistors and apparatus for enabling the resistors. The ink barrier layer defines ink channels including ink chambers disposed over associated ink firing resistors, and the nozzles in the orifice plate are aligned with associated ink chambers. Ink drop generator regions are formed by the ink chambers and portions of the thin film substructure and the orifice plate that are adjacent the ink chambers.

[0005] The thin film substructure is typically comprised of a substrate such as silicon on which are formed various thin film layers that form thin film ink firing resistors, apparatus for enabling the resistors, and also interconnections to bonding pads that are provided for external electrical connections to the printhead. The ink barrier layer is typically a polymer material that is laminated as a dry film to the thin film substructure, and is designed to be photodefinable and both UV and thermally curable. In an ink jet printhead of a slot feed design, ink is fed from one or more ink reservoirs to the various ink chambers through one or more ink feed slots formed in the substrate.

[0006] An example of the physical arrangement of the orifice plate, ink barrier layer, and thin film substructure is illustrated at page 44 of the Hewlett-Packard Journal of February 1994, cited above. Further examples of ink jet printheads are set forth in commonly

assigned U.S. Patent 4,719,477 and U.S. Patent 5,317,346, both of which are incorporated herein by reference.

[0007] Considerations with thin film ink jet printheads include increased substrate size and/or substrate fragility as more ink drop generators and/or ink feed slots are employed. There is accordingly a need for an ink jet printhead that is compact and has a large number of ink drop generators.

SUMMARY OF THE INVENTION

[0008] The disclosed invention is directed to a narrow ink jet printhead having four columnar arrays of ink drop generators configured for monochrome single-pass printing at a print resolution having a media axis dot spacing that is less than the columnar nozzle spacing of the ink drop generators. In accordance with a more specific aspect of the invention, the printhead includes high resistance heater resistors and efficient FET drive circuits that are configured to compensate for variation in parasitic resistance presented by power traces.

BRIEF DESCRIPTION OF THE DRAWINGS

[0009] The advantages and features of the disclosed invention will readily be appreciated by persons skilled in the art from the following detailed description when read in conjunction with the drawing wherein:

[0010] FIG. 1 is an unscaled schematic top plan view illustration of the layout of ink drop generators and primitive select of an ink jet printhead that employs the invention.

[0011] FIG. 2 is an unscaled schematic top plan view illustration of the layout of ink drop generators and ground busses of the ink jet printhead of FIG. 1.

[0012] FIG. 3 is a schematic, partially broken away perspective view of the ink jet printhead of FIG. 1.

[0013] FIG. 4 is an unscaled schematic partial top plan illustration of the ink jet printhead of FIG. 1.

[0014] FIG. 5 is a schematic depiction of generalized layers of the thin film substructure of the printhead of FIG. 1.

[0015] FIG. 6 is a partial top plan view generally illustrating the layout of a representative FET drive circuit array and a ground bus of the printhead of FIG. 1.

[0016] FIG. 7 is an electrical circuit schematic depicting the electrical connections of a heater resistor and an FET drive circuit of the printhead of FIG. 1.

[0017] FIG. 8 is a schematic plan view of representative primitive select traces of the printhead of FIG. 1.

[0018] FIG. 9 is a schematic plan view of an illustrative implementation of an FET drive circuit and a ground bus of the printhead of FIG. 1.

[0019] FIG. 10 is a schematic elevational cross sectional view of the FET drive circuit of FIG. 9.

[0020] FIG. 11 is an unscaled schematic perspective view of a printer in which the printhead of the invention can be employed.

DETAILED DESCRIPTION OF THE DISCLOSURE

[0021] In the following detailed description and in the several figures of the drawing, like elements are identified with like reference numerals.

[0022] Referring now to FIG. 1 - 4, schematically illustrated therein are unscaled schematic plan views and

perspective views of an ink jet printhead 100 in which the invention can be employed and which generally includes (a) a thin film substructure or die 11 comprising a substrate such as silicon and having various thin film layers formed thereon, (b) an ink barrier layer 12 disposed on the thin film substructure 11, and (c) an orifice or nozzle plate 13 laminarily attached to the top of the ink barrier 12.

[0023] The thin film substructure 11 comprises an integrated circuit die that is formed for example pursuant to conventional integrated circuit techniques, and as schematically depicted in FIG. 5 generally includes a silicon substrate 111a, an FET gate and dielectric layer 111b, a resistor layer 111c, and a first metallization layer 111d. Active devices such as drive FET circuits described more particularly herein are formed in the top portion of the silicon substrate 111a and the FET gate and dielectric layer 111b, which includes a gate oxide layer, polysilicon gates, and a dielectric layer adjacent the resistor layer 111c. Thin film heater resistors 56 are formed by the respective patterning of the resistor layer 111c and the first metallization layer 111d. The thin film substructure further includes a composite passivation layer 111e comprising for example a silicon nitride layer and a silicon carbide layer, and a tantalum mechanical passivation layer 111f that overlies at least the heater resistors 56. A gold conductive layer 111g overlies the tantalum layer 111f.

[0024] The ink barrier layer 12 is formed of a dry film that is heat and pressure laminated to the thin film substructure 11 and photodefined to form therein ink chambers 19 disposed over heater resistors 56 and ink channels 29. Gold bonding pads 74 engagable for external electrical connections are formed in the gold layer at longitudinally spaced apart, opposite ends of the thin film

substructure 11 and are not covered by the ink barrier layer 12. By way of illustrative example, the barrier layer material comprises an acrylate based photopolymer dry film such as the "Parad" brand photopolymer dry film obtainable from E.I. duPont de Nemours and Company of Wilmington, Delaware. Similar dry films include other duPont products such as the "Riston" brand dry film and dry films made by other chemical providers. The orifice plate 13 comprises, for example, a planar substrate comprised of a polymer material and in which the orifices are formed by laser ablation, for example as disclosed in commonly assigned U.S. Patent 5,469,199, incorporated herein by reference. The orifice plate can also comprise a plated metal such as nickel.

[0025] As depicted in FIG. 3, the ink chambers 19 in the ink barrier layer 12 are more particularly disposed over respective ink firing heater resistors 56, and each ink chamber 19 is defined by interconnected edges or walls of a chamber opening formed in the barrier layer 12. The ink channels 29 are defined by further openings formed in the barrier layer 12, and are integrally joined to respective ink firing chambers 19. The ink channels 29 open towards a feed edge of an adjacent ink feed slot 71 and receive ink from such ink feed slot.

[0026] The orifice plate 13 includes orifices or nozzles 21 disposed over respective ink chambers 19, such that each ink firing heater resistor 56, an associated ink chamber 19, and an associated orifice 21 are aligned and form an ink drop generator 40. Each of the heater resistors has a nominal resistance of at least 100 ohms, for example about 120 or 130 ohms, and can comprise a segmented resistor as shown in FIG. 9, wherein a heater resistor 56 is comprised of two resistor regions 56a, 56b connected by a metallization region 59. This resistor structure provides

for a resistance that is greater than a single resistor region of the same area.

[0027] While the disclosed printheads are described as having a barrier layer and a separate orifice plate, it should be appreciated that the printheads can be implemented with an integral barrier/orifice structure that can be made, for example, using a single photopolymer layer that is exposed with a multiple exposure process and then developed.

[0028] The ink drop generators 40 are arranged in columnar arrays or groups 61 that extend along a reference axis L and are spaced apart from each other laterally or transversely relative to the reference axis L. The heater resistors 56 of each ink drop generator group are generally aligned with the reference axis L and have a predetermined center to center spacing or nozzle pitch P along the reference axis L. The nozzle pitch P can be 1/600 inch or greater, such as 1/300 inch. Each columnar array 61 of ink drop generators includes for example 100 or more ink drop generators (i.e., at least 100 ink drop generators).

[0029] By way of illustrative example, the thin film substructure 11 can be rectangular, wherein opposite edges 51, 52 thereof are longitudinal edges of a length dimension LS while longitudinally spaced apart, opposite edges 53, 54 are of a width or lateral dimension WS that is less than the length LS of the thin film substructure 11. The longitudinal extent of the thin film substructure 11 is along the edges 51, 52 which can be parallel to the reference axis L. In use, the reference axis L can be aligned with what is generally referred to as the media advance axis. For convenience, the longitudinally separated ends of the thin film substructure will also be referred to by the reference number 53, 54 used to refer to the edges at such ends.

[0030] While the ink drop generators 40 of each columnar array 61 of ink drop generators are illustrated as being substantially collinear, it should be appreciated that some of the ink drop generators 40 of an array of ink drop generators can be slightly off the center line of the column, for example to compensate for firing delays.

[0031] Insofar as each of the ink drop generators 40 includes a heater resistor 56, the heater resistors are accordingly arranged in columnar groups or arrays that correspond to the columnar arrays of ink drop generators. For convenience, the heater resistor arrays or groups will be referred to by the same reference number 61.

[0032] The thin film substructure 11 of the printhead 100 of FIG. 1 - 4 more particularly includes two ink feed slots 71 that are aligned with the reference axis L, and are spaced apart from each other transversely relative to the reference axis L. The ink feed slots 71 respectively feed four columns 61 of ink drop generators respectively located on opposite sides of the two ink feed slots 71, wherein the ink channels open towards an edge formed by an associated ink feed slot in the thin film substructure. In this manner, opposite edges of each ink feed slot forms a feed edge and each of the two ink feed slots comprises a dual edge ink feeding slot. By way of specific implementation, the printhead 100 of FIGS. 1 - 4 is a monochrome printhead wherein both ink feed slots 71 provides ink of the same color such as black, such that all four columns 61 of ink drop generators produce ink drops of the same color.

[0033] The column pitch or spacing CP between columns on either side of an ink feed slot is less than or equal to 630 micrometers (μm) (i.e., at most 630 μm), and the column pitch or spacing CP' between the columns that are inboard

of the ink feed slots is less than or equal to 800 μm (i.e., at most 800 μm).

[0034] The nozzle pitch, the stagger or offset of the nozzles from one column to an adjacent column, along the reference axis L, and the ink drop volume are more particularly configured to enable a single pass, monochrome dot spacing along the reference axis L that is 1/4th of the nozzle pitch P which is in the range of 1/300 inch to 1/600 inch. The drop volume can be in the range of 3 to 7 picoliters for dye based inks (as a specific example about 5 picoliters), and in the range of 12 to 19 picoliters of pigment based inks (as a specific example about 16 picoliters). For a nozzle pitch of 1/300 inch the stagger or offset along the reference axis L between adjacent columns of nozzles in a given transverse direction can be 1/1200 inch. In other words, the second column from the left is offset by 1/1200 inch along a selected direction along the reference axis L relative to the leftmost column. The third column from the left is offset by 1/1200 inch along the selected direction along the reference axis relative to the second column from the left. The fourth column from the left is offset by 1/1200 inch along the selected direction along the reference axis L relative to the third column from the left.

[0035] Thus, a nozzle pitch P of 1/300 inch would provide for a single pass dot spacing of 1/1200 inch which corresponds to a single pass print resolution of 1200 dpi. A nozzle pitch P of 1/600 inch would provide for a single pass dot spacing of 1/2400 which corresponds to a single pass print resolution of 1/2400 dpi.

[0036] More particularly for an implementation having four columnar arrays 61 each having at least 100 ink drop generators having a nozzle pitch P of 1/300 inch, by way of illustrative example, the length LS of the thin film

substructure 11 can be about 11500 μm , and the width WS of the thin film substructure can be about 2900 μm . Generally, the length/width aspect ratio (i.e., LS/WS) of the thin film substructure can be greater than 3.7.

[0037] Respectively adjacent and associated with the columnar arrays 61 of ink drop generators 40 are columnar FET drive circuit arrays 81 formed in the thin film substructure 11 of the printheads 100A, 100B, as schematically depicted in FIG. 6 for a representative columnar array 61 of ink drop generators. Each FET drive circuit array 81 includes a plurality of FET drive circuits 85 having drain electrodes respectively connected to respective heater resistors 56 by heater resistor leads 57a. Associated with each FET drive circuit array 81 and the associated array of ink drop generators is a columnar ground bus 181 to which the source electrodes of all of the FET drive circuits 85 of the associated FET drive circuit array 81 are electrically connected. Each columnar array 81 of FET drive circuits and the associated ground bus 181 extend longitudinally along the associated columnar array 61 of ink drop generators, and are at least longitudinally co-extensive with the associated columnar array 61. Each ground bus 181 is electrically connected to at least one bond pad 74 at one end of the printhead structure and to at least one bond pad 74 at the other end of the printhead structure as schematically depicted in FIGS. 1 and 2.

[0038] The ground busses 181 and heater resistor leads 57a are formed in the metallization layer 111c (FIG. 5) of the thin film substructure 11, as are the heater resistor leads 57b, and the drain and source electrodes of the FET drive circuits 85 described further herein.

[0039] The FET drive circuits 85 of each columnar array of FET drive circuits are controlled by an associated columnar array 31 of decoder logic circuits 35 that decode

address information on an adjacent address bus 33 that is connected to appropriate bond pads 74 (FIG. 6). The address information identifies the ink drop generators that are to be energized with ink firing energy, as discussed further herein, and is utilized by the decoder logic circuits 35 to turn on the FET drive circuit of an addressed or selected ink drop generator.

[0040] As schematically depicted in FIG. 7, one terminal of each heater resistor 56 is connected via a primitive select trace to a bond pad 74 that receives an ink firing primitive select signal PS. In this manner, since the other terminal of each heater resistor 56 is connected to the drain terminal of an associated FET drive circuit 85, ink firing energy PS is provided to the heater resistor 56 if the associated FET drive circuit is ON as controlled by the associated decoder logic circuit 35.

[0041] As schematically depicted in FIG. 8 for a representative columnar array 61 of ink drop generators, the ink drop generators of a columnar array 61 of ink drop generators can be organized into four primitive groups 61a, 61b, 61c, 61d of contiguously adjacent ink drop generators, and the heater resistors 56 of a particular primitive group are electrically connected to the same one of four primitive select traces 86a, 86b, 86c, 86d, such that the ink drop generators of a particular primitive group are switchably coupled in parallel to the same ink firing primitive select signal PS. For the specific example wherein the number N of ink drop generators in a columnar array is an integral multiple of 4, each primitive group includes N/4 ink drop generators. For reference, the primitive groups 61a, 61b, 61c, 61d are arranged in sequence from the lateral edge 53 toward the lateral edge 54.

[0042] FIG. 8 more particularly sets forth a schematic top plan view of primitive select traces 86a, 86b, 86c, 86d for an associated columnar array 61 of drop generators and an associated columnar array 81 of FET drive circuits 85 (FIG. 6) as implemented for example by traces in the gold metallization layer 111g (FIG. 5) that is above and dielectrically separated from the associated array 81 of FET drive circuit and ground bus 181. The primitive select traces 86a, 86b, 86c, 86d are respectively electrically connected to the four primitive groups 61a, 61b, 61c, 61d by resistor leads 57b (FIG. 8) formed in the metallization layer 111c and interconnecting vias 58 (FIG. 8) that extend between the primitive select traces and the resistor leads 57b.

[0043] The first primitive select trace 86a extends longitudinally along the first primitive group 61a and overlies a portion of heater resistor leads 57b (FIG. 9) that are respectively connected to heater resistors 56 of the first primitive group 61a, and is connected by vias 58 (FIG. 9) to such heater resistor leads 57b. The second primitive select trace 86b includes a section that extends along the second primitive group 61b and overlies a portion of heater resistor leads 57b (FIG. 9) that are respectively connected to heater resistors 56 of the second primitive group 61b, and is connected by vias 58 to such heater resistor leads 57b. The second trace 86b includes a further section that extends along the first primitive select trace 86a on the side of the first primitive select trace 86a that is opposite the heater resistors 56 of the first primitive group 61a. The second primitive select trace 86b is generally L-shaped wherein the second section is narrower than the first section so as to bypass the first primitive select trace 86a which is narrower than the wider section of the second primitive select trace 86b.

[0044] The first and second primitive select traces 86a, 86b are generally at least coextensive longitudinally with the first and second primitive groups 61a, 61b, and are respectively appropriately connected to respective bond pads 74 disposed at the lateral edge 53 which is closest to the first and second primitive select traces 86a, 86b.

[0045] The fourth primitive select trace 86d extends longitudinally along the fourth primitive group 61d and overlies a portion of heater resistor leads 57b (FIG. 9) that are connected to heater resistors 56 of the fourth primitive group 61d, and is connected by vias 58 to such heater resistor leads 57b. The third primitive select trace 86c includes a section that extends along the third primitive group 61c and overlies a portion of heater resistor leads 57b (FIG. 9) that are connected to heater resistors 56 of the third primitive group 61c, and is connected by vias 58 to such heater resistor leads 57b. The third primitive select trace 86c includes a further section that extends along the fourth primitive select trace 86d. The third primitive select trace 86c is generally L-shaped wherein the second section is narrower than the first section so as to bypass the fourth primitive select trace 86d which is narrower than the wider section of the third primitive select trace 86c.

[0046] The third and fourth primitive select traces 86c, 86d are generally at least coextensive longitudinally with the third and fourth primitive groups 61c, 61d, and are respectively appropriately connected to respective bond pads 74 disposed at the lateral edge 54 that is closest to the third and fourth primitive select traces 86c, 86d.

[0047] By way of specific example, the primitive select traces 86a, 86b, 86c, 86d for a columnar array 61 of ink drop generators overlie the FET drive circuits and the ground bus associated with the columnar array of ink drop

generators, and are contained in a region that is longitudinally coextensive with the associated columnar array 61. In this manner, four primitive select traces for the four primitives of a columnar array 61 of ink drop generators extend along the array toward the ends of the printhead substrate. More particularly, a first pair of primitive select traces for a first pair of primitive groups 61a, 61b disposed in one-half of the length of the printhead substrate are contained in a region that extends along such first pair of primitive groups, while a second pair of primitive select traces for a second pair of primitive groups 61c, 61d disposed in the other half of the length of the printhead substrate are contained in a region that extends along such second pair of primitive groups.

[0048] For ease of reference, the primitive select traces 86 and the associated ground bus that electrically connect the heater resistors 56 and associated FET drive circuits 85 to bond pads 74 are collectively referred to as power traces. Also for ease of reference, the primitive select traces 86 can be referred to as to the high side or non-grounded power traces.

[0049] Generally, the parasitic resistance (or on-resistance) of each of the FET drive circuits 85 is configured to compensate for the variation in the parasitic resistance presented to the different FET drive circuits 85 by the parasitic path formed by the power traces, so as to reduce the variation in the energy provided to the heater resistors. In particular, the power traces form a parasitic path that presents a parasitic resistance to the FET circuits that varies with location on the path, and the parasitic resistance of each of the FET drive circuits 85 is selected so that the combination of the parasitic resistance of each FET drive circuit 85 and the parasitic resistance of the power traces as presented to the FET

drive circuit varies only slightly from one ink drop generator to another. Insofar as the heater resistors 56 are all of substantially the same resistance, the parasitic resistance of each FET drive circuit 85 is thus configured to compensate for the variation of the parasitic resistance of the associated power traces as presented to the different FET drive circuits 85. In this manner, to the extent that substantially equal energies are provided to the bond pads connected to the power traces, substantially equal energies can be provided to the different heater resistors 56.

[0050] Referring more particularly to FIGS. 9 and 10, each of the FET drive circuits 85 comprises a plurality of electrically interconnected drain electrode fingers 87 disposed over drain region fingers 89 formed in the silicon substrate 111a (FIG. 5), and a plurality of electrically interconnected source electrode fingers 97 interdigitated or interleaved with the drain electrodes 87 and disposed over source region fingers 99 formed in the silicon substrate 111a. Polysilicon gate fingers 91 that are interconnected at respective ends are disposed on a thin gate oxide layer 93 formed on the silicon substrate 111a. A phosphosilicate glass layer 95 separates the drain electrodes 87 and the source electrodes 97 from the silicon substrate 111a. A plurality of conductive drain contacts 88 electrically connect the drain electrodes 87 to the drain regions 89, while a plurality of conductive source contacts 98 electrically connect the source electrodes 97 to the source regions 99.

[0051] The area occupied by each FET drive circuit is preferably small, and the on-resistance of each FET drive circuit is preferably low, for example less than or equal to 14 or 16 ohms (i.e., at most 14 or 16 ohms), which requires efficient FET drive circuits. For example, the

on-resistance R_{on} can be related to FET drive circuit area A as follows:

$$R_{on} < (250,000 \text{ ohms} \cdot \text{micrometers}^2) / A$$

wherein the area A is in micrometers² (μm^2). This can be accomplished for example with a gate oxide layer 93 having a thickness that is less than or equal to 800 Angstroms (i.e., at most 800 Angstroms), or a gate length that is less than 4 μm . Also, having a heater resistor resistance of at least 100 ohms allows the FET circuits to be made smaller than if the heater resistors had a lower resistance, since with a greater heater resistor value a greater FET turn-on resistance can be tolerated from a consideration of distribution of energy between parasitics and the heater resistors.

[0052] As a particular example, the drain electrodes 87, drain regions 89, source electrodes 97, source regions 99, and the polysilicon gate fingers 91 can extend substantially orthogonally or transversely to the reference axis L and to the longitudinal extent of the ground busses 181. Also, for each FET circuit 85, the extent of the drain regions 89 and the source regions 99 transversely to the reference axis L is the same as extent of the gate fingers transversely to the reference axis L , as shown in FIG. 6, which defines the extent of the active regions transversely to the reference axis L . For ease of reference, the extent of the drain electrode fingers 87, drain region fingers 89, source electrode fingers 97, source region fingers 99, and polysilicon gate fingers 91 can be referred to as the longitudinal extent of such elements insofar as such elements are long and narrow in a strip-like or finger-like manner.

[0053] By way of illustrative example, the on-resistance of each of the FET circuits 85 is individually configured by controlling the longitudinal extent or length of a continuously non-contacted segment of the drain region fingers, wherein a continuously non-contacted segment is devoid of electrical contacts 88. For example, the continuously non-contacted segments of the drain region fingers can begin at the ends of the drain regions 89 that are furthest from the heater resistor 56. The on-resistance of a particular FET circuit 85 increases with increasing length of the continuously non-contacted drain region finger segment, and such length is selected to determine the on-resistance of a particular FET circuit.

[0054] As another example, the on-resistance of each FET circuit 85 can be configured by selecting the size of the FET circuit. For example, the extent of an FET circuit transversely to the reference axis L can be selected to define the on-resistance.

[0055] For a typical implementation wherein the power traces for a particular FET circuit 85 are routed by reasonably direct paths to bond pads 74 on the closest of the longitudinally separated ends of the printhead structure, parasitic resistance increases with distance from the closest end of the printhead, and the on-resistance of the FET drive circuits 85 is decreased (making an FET circuit more efficient) with distance from such closest end, so as to offset the increase in power trace parasitic resistance. As a specific example, as to continuously non-contacted drain finger segments of the respective FET drive circuits 85 that start at the ends of the drain region fingers that are furthest from the heater resistors 56, the lengths of such segments are decreased with distance from the closest one of the longitudinally separated ends of the printhead structure.

[0056] Each ground bus 181 is formed of the same thin film metallization layer as the drain electrodes 87 and the source electrodes 97 of the FET circuits 85, and the active areas of each of the FET circuits comprised of the source and drain regions 89, 99 and the polysilicon gates 91 advantageously extend beneath an associated ground bus 181. This allows the ground bus and FET circuit arrays to occupy narrower regions which in turn allows for a narrower, and thus less costly, thin film substructure.

[0057] Also, in an implementation wherein the continuously non-contacted segments of the drain region fingers start at the ends of the drain region fingers that are furthest from the heater resistors 56, the extent of each ground bus 181 transversely or laterally to the reference axis L and toward the associated heater resistors 56 can be increased as the length of the continuously non-contacted drain finger sections is increased, since the drain electrodes do not need to extend over such continuously non-contacted drain finger sections. In other words, the width W of a ground bus 181 can be increased by increasing the amount by which the ground bus overlies the active regions of the FET drive circuits 85, depending upon the length of the continuously non-contacted drain region segments. This is achieved without increasing the width of the region occupied by a ground bus 181 and its associated FET drive circuit array 81 since the increase is achieved by increasing the amount of overlap between the ground bus and the active regions of the FET drive circuits 85. Effectively, at any particular FET circuit 85, the ground bus can overlap the active region transversely to the reference axis L by substantially the length of the non-contacted segments of the drain regions.

[0058] For the specific example wherein the continuously non-contacted drain region segments start at the ends of

the drain region fingers that are furthest from the heater resistors 56 and wherein the lengths of such continuously non-contacted drain region segments decrease with distance from the closest end of the printhead structure, the modulation or variation of the width W of a ground bus 181 with the variation of the length of the continuously non-contacted drain region segments provides for a ground bus having a width W_{181} that increases with proximity to the closest end of the printhead structure, as depicted in FIG. 8. Since the amount of shared currents increases with proximity to the bond pads 74, such shape advantageously provides for decreased ground bus resistance with proximity to the bond pads 74.

[0059] Ground bus resistance can also be reduced by laterally extending portions of the ground bus 181 into longitudinally spaced apart areas between the decoder logic circuits 35. For example, such portions can extend laterally beyond the active regions by the width of the region in which the decoder logic circuits 35 are formed.

[0060] The following circuitry portions associated with a columnar array of ink drop generators can be contained in respective regions having the following widths that are indicated in FIGS. 6 and 8 by the reference designations that follow the width values.

REGIONS THAT CONTAIN:	WIDTH
Resistor leads 57	About 95 micrometers (μm) or less (W_{57})
FET circuits 81	At most 250 μm , or at most 180 μm , for example (W_{81})
Decode logic circuits 31	About 34 μm or less (W_{31})
Primitive select traces 86	About 290 μm or less (W_{86})

These widths are measured orthogonally or laterally to the longitudinal extent of the printhead substrate which is aligned with the reference axis L.

[0061] Referring now to FIG. 11, set forth therein is a schematic perspective view of an example of an ink jet printing device 20 in which the above described printheads can be employed. The ink jet printing device 20 of FIG. 11 includes a chassis 122 surrounded by a housing or enclosure 124, typically of a molded plastic material. The chassis 122 is formed for example of sheet metal and includes a vertical panel 122a. Sheets of print media are individually fed through a print zone 125 by an adaptive print media handling system 126 that includes a feed tray 128 for storing print media before printing. The print media may be any type of suitable printable sheet material such as paper, card-stock, transparencies, Mylar, and the like, but for convenience the illustrated embodiments described as using paper as the print medium. A series of conventional motor-driven rollers including a drive roller 129 driven by a stepper motor may be used to move print media from the feed tray 128 into the print zone 125. After printing, the drive roller 129 drives the printed sheet onto a pair of retractable output drying wing members 130 which are shown extended to receive a printed sheet. The wing members 130 hold the newly printed sheet for a short time above any previously printed sheets still drying in an output tray 132 before pivotally retracting to the sides, as shown by curved arrows 133, to drop the newly printed sheet into the output tray 132. The print media handling system may include a series of adjustment mechanisms for accommodating different sizes of print media, including letter, legal, A-4, envelopes, etc., such as a sliding length adjustment arm 134 and an envelope feed slot 135.

[0062] The printer of FIG. 11 further includes a printer controller 136, schematically illustrated as a microprocessor, disposed on a printed circuit board 139 supported on the rear side of the chassis vertical panel 122a. The printer controller 136 receives instructions from a host device such as a personal computer (not shown) and controls the operation of the printer including advance of print media through the print zone 125, movement of a print carriage 140, and application of signals to the ink drop generators 40.

[0063] A print carriage slider rod 138 having a longitudinal axis parallel to a carriage scan axis is supported by the chassis 122 to sizeably support a print carriage 140 for reciprocating translational movement or scanning along the carriage scan axis. The print carriage 140 supports first and second removable ink jet printhead cartridges 150, 152 (each of which is sometimes called a "pen," "print cartridge," or "cartridge"). The print cartridges 150, 152 include respective printheads 154, 156 that respectively have generally downwardly facing nozzles for ejecting ink generally downwardly onto a portion of the print media that is in the print zone 125. The print cartridges 150, 152 are more particularly clamped in the print carriage 140 by a latch mechanism that includes clamping levers, latch members or lids 170, 172.

[0064] For reference, print media is advanced through the print zone 125 along a media axis which is parallel to the tangent to the portion of the print media that is beneath and traversed by the nozzles of the cartridges 150, 152. If the media axis and the carriage axis are located on the same plane, as shown in FIG. 9, they would be perpendicular to each other.

[0065] An anti-rotation mechanism on the back of the print carriage engages a horizontally disposed anti-pivot

bar 185 that is formed integrally with the vertical panel 122a of the chassis 122, for example, to prevent forward pivoting of the print carriage 140 about the slider rod 138.

[0066] By way of illustrative example, the print cartridge 150 is a monochrome printing cartridge while the print cartridge 152 is a tri-color printing cartridge.

[0067] The print carriage 140 is driven along the slider rod 138 by an endless belt 158 which can be driven in a conventional manner, and a linear encoder strip 159 is utilized to detect position of the print carriage 140 along the carriage scan axis, for example in accordance with conventional techniques.

[0068] Although the foregoing has been a description and illustration of specific embodiments of the invention, various modifications and changes thereto can be made by persons skilled in the art without departing from the scope and spirit of the invention as defined by the following claims.

23

CLAIMS

What is claimed is:

1. An ink jet printhead, comprising:
a printhead substrate (11) including a plurality of thin film layers;

four side by side columnar arrays (61) of drop generators (40) formed in said printhead substrate and extending along a longitudinal extent;

each columnar array of drop generators having at least 100 drop generators separated by a drop generator pitch P;

said four columnar arrays of drop generators comprising a first columnar array and a second columnar array separated from each other by at most 630 micrometers, and a third columnar array and a fourth columnar array separated from each other by at most 630 micrometers;

said drop generators producing ink drops of a same predetermined color and having a drop volume that enables single pass monochrome printing of a resolution that is $1/(4P)$ dpi along a print axis parallel to said longitudinal extent; and

four columnar arrays (81) of FET drive circuits (85) formed in said printhead substrate respectively adjacent said columnar arrays of drop generators for energizing said columnar arrays of drop generators.

2. The printhead of claim 1 further including a first ink feed slot (71) and a second ink feed slot (71), and wherein:

said first columnar array of drop generators and said second columnar array of drop generators disposed on either side of said first ink feed slot; and

said third columnar array of drop generators and said fourth columnar array of drop generators disposed on either side of said second ink feed slot.

3. The printhead of claim 2 wherein said second columnar array of drop generators and said third columnar array of drop generators are separated by at most 800 micrometers.

4. The printhead of claim 1 wherein P is in the range of 1/300th inch to 1/600th inch.

5. The printhead of claim 1 wherein said drop generators are configured to emit drops having a drop volume in the range of 12 to 19 picoliters.

6. The printhead of claim 1 wherein said drop generators are configured to emit drops having a drop volume in the range of 3 to 7 picoliters.

7. The printhead of claim 1 wherein each of said drop generators includes a heater resistor (56) having a resistance that is at least 100 ohms.

8. The printhead of claim 1 further including ground busses (181) that overlap active regions of said FET drive circuits.

9. The printhead of claim 1 wherein each of said FET drive circuits has an on-resistance that is less than $(250,000 \text{ ohm} \cdot \text{micrometers}^2)/A$, wherein A is an area of such FET drive circuit in micrometers^2 .

10. The printhead of claim 9 wherein each of said FET drive circuits has a gate oxide (93) thickness that is at most 800 Angstroms.

11. The printhead of claim 9 wherein each of said FET drive circuits has a gate length that is less than 4 micrometers.

12. The printhead of claim 1 wherein each of said FET drive circuits has an on-resistance of at most 14 ohms.

13. The printhead of claim 1 wherein each of said FET drive circuits has an on-resistance of at most 16 ohms.

14. The printhead of claim 1 further including power traces (86a, 86b, 86c, 86d, 181), and wherein the FET drive circuits are configured to compensate for a parasitic resistance presented by said power traces.

15. The printhead of claim 14 wherein respective on-resistances of said FET circuits are selected to compensate for variation of a parasitic resistance presented by said power traces.

16. The printhead of claim 15 wherein a size of each of said FET circuits is selected to set said on-resistance.

17. The printhead of claim 15 wherein each of said FET circuits includes:

drain electrodes (87);

drain regions (89);

drain contacts (88) electrically connecting said drain electrodes to said drain regions;

source electrodes (97);

source regions (99);

source contacts (98) electrically connecting said source electrodes to said source regions; and

wherein said drain regions are configured to set an on-resistance of each of said FET circuits to compensate for variation of a parasitic resistance presented by said power traces.

18. The printhead of claim 17 wherein said drain regions comprise elongated drain regions each including a continuously non-contacted segment having a length that is selected to set said on-resistance.

19. The printhead of claim 1 wherein each of said columnar arrays of FET drive circuits is contained in a region having a width that is at most 180 micrometers.

20. The printhead of claim 1 wherein each of said columnar arrays of FET drive circuits is contained in a region having a width that is at most 250 micrometers.

21. The printhead of claim 1 wherein said printhead substrate has a length LS and a width WS , and wherein LS/WS is greater than 3.7.

22. The printhead of claim 21 wherein WS is about 2900 micrometers.

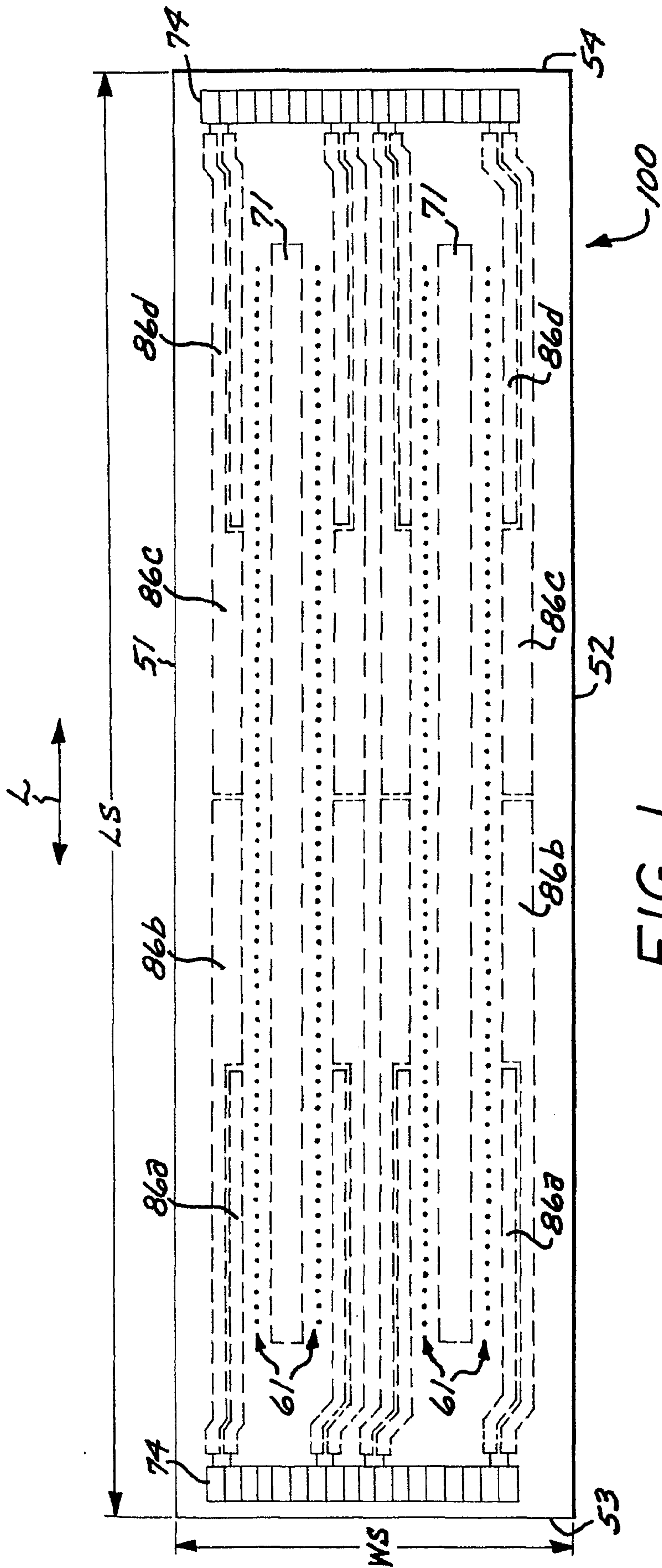

FIG. 1

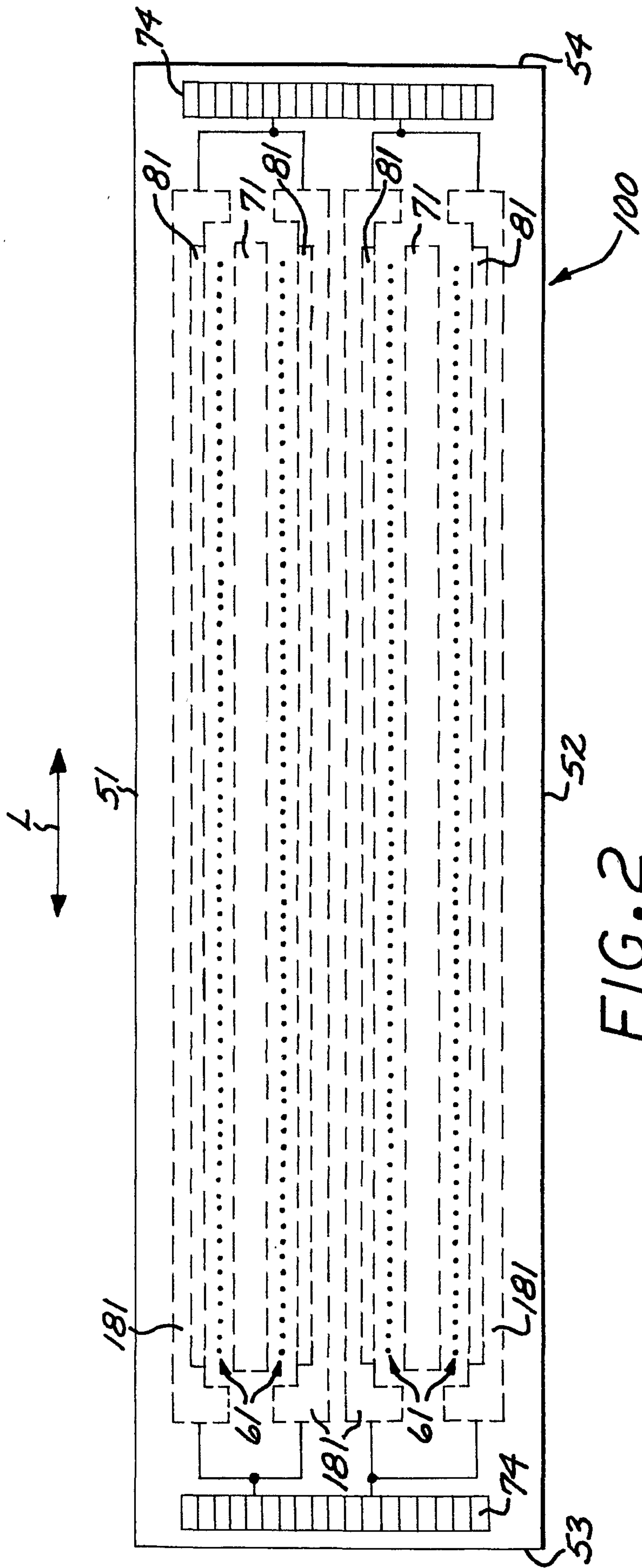

FIG. 2

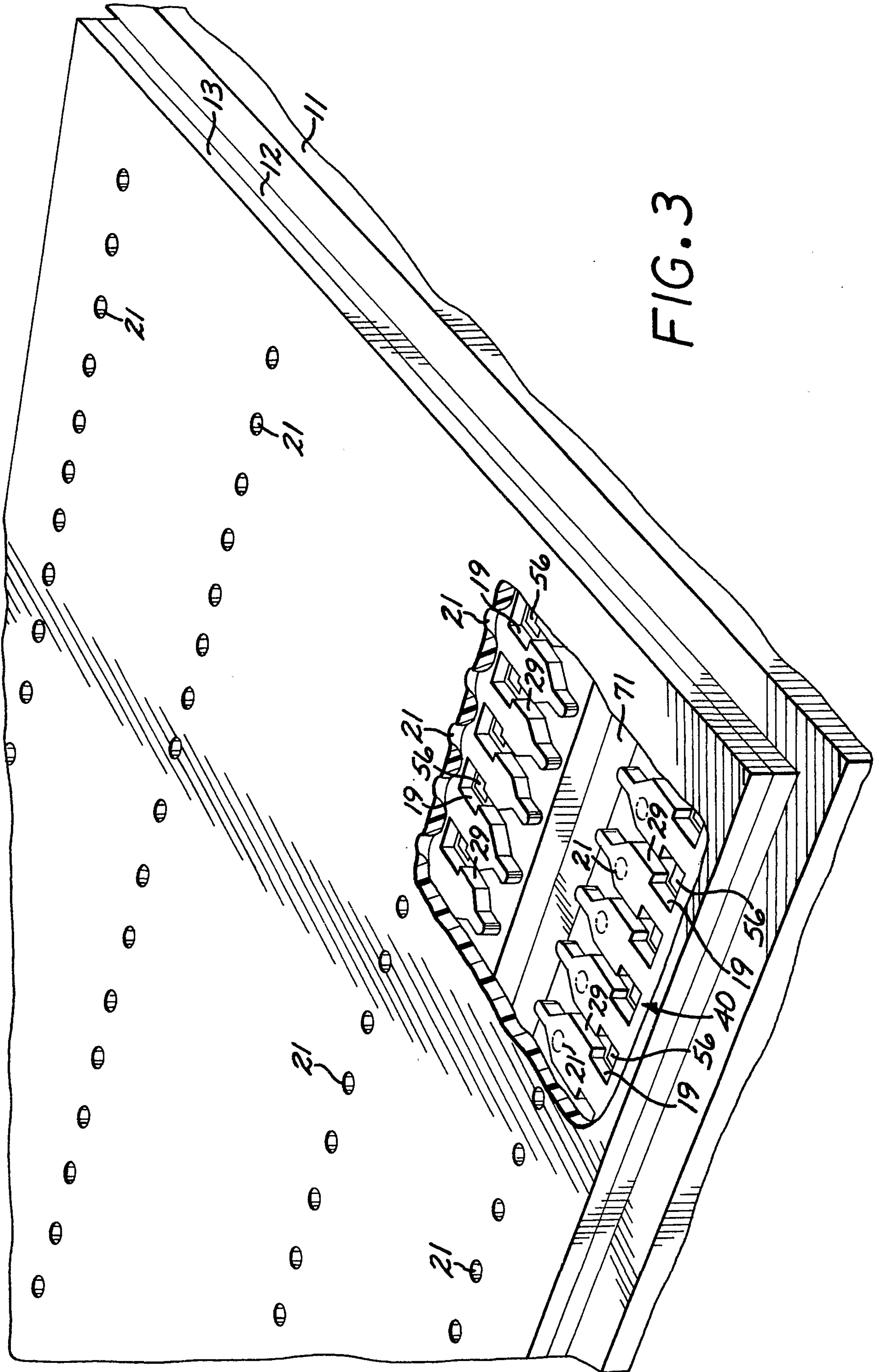

FIG. 3

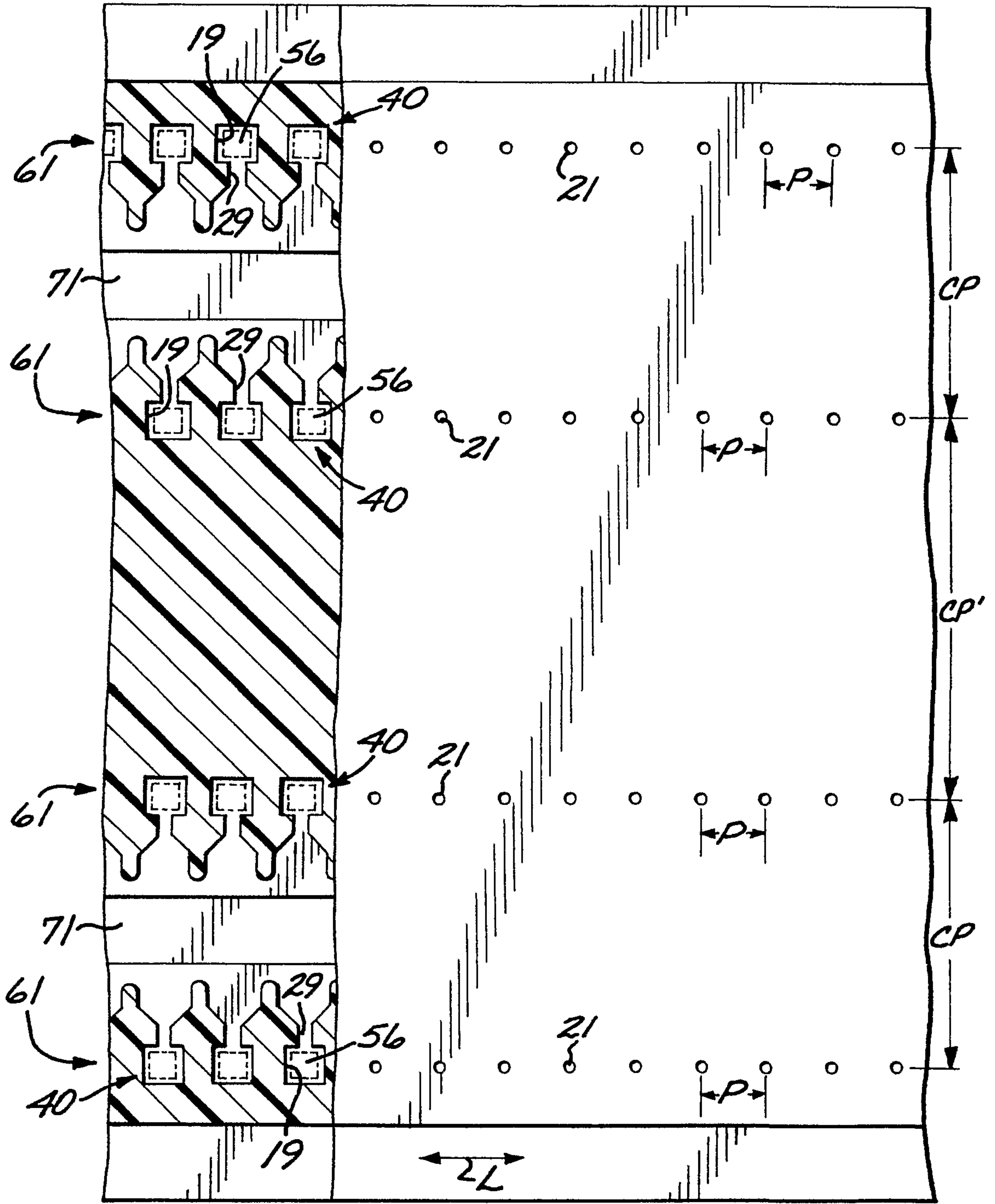

FIG. 4

FIG. 5

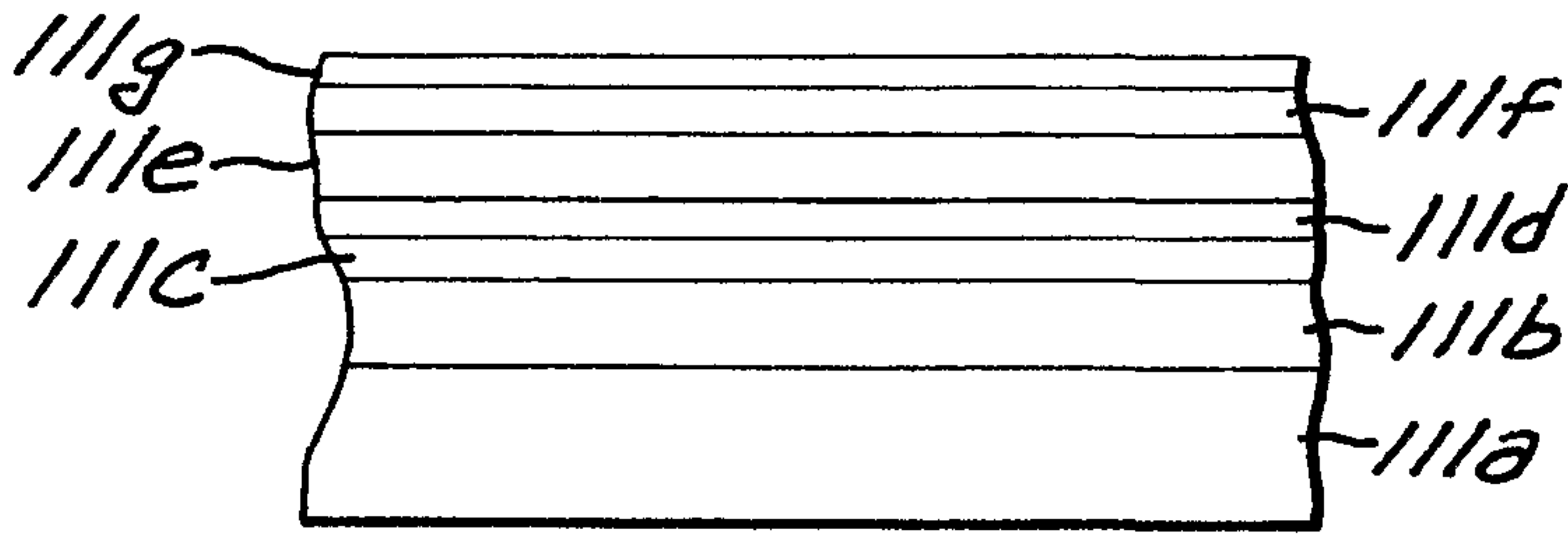

FIG. 8

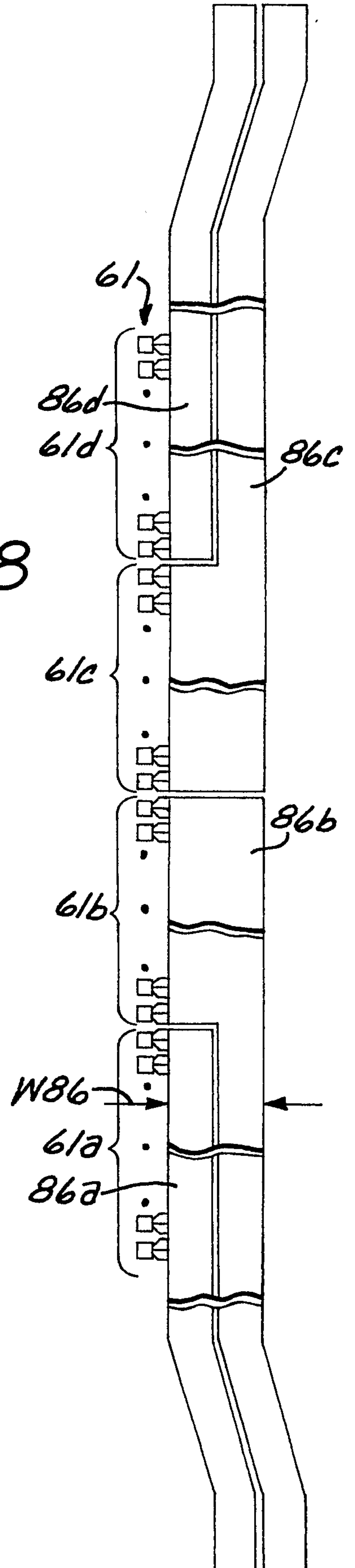

FIG. 7

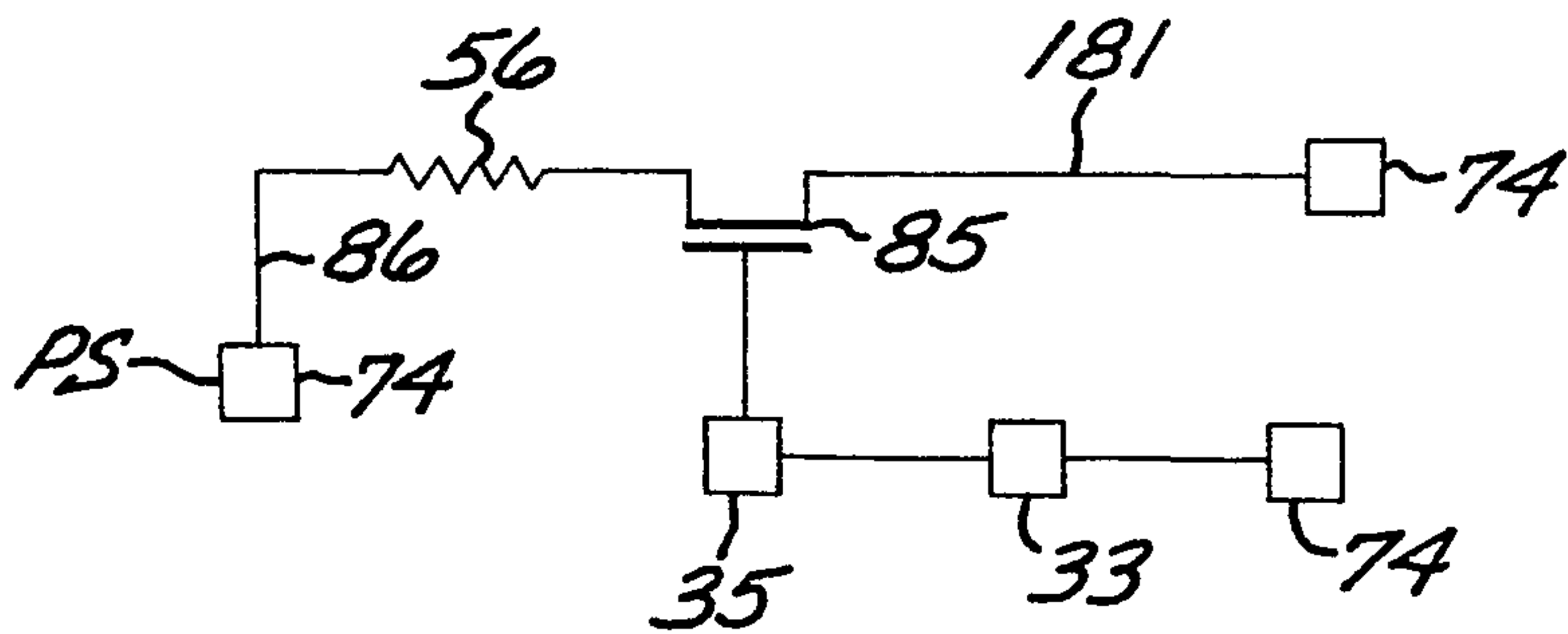

FIG. 6

