

(12) STANDARD PATENT
(19) AUSTRALIAN PATENT OFFICE

(11) Application No. **AU 2012262223 B2**

(54) Title
Dental appliance

(51) International Patent Classification(s)
A61F 5/56 (2006.01)

(21) Application No: **2012262223**

(22) Date of Filing: **2012.05.31**

(87) WIPO No: **WO12/166896**

(30) Priority Data

(31) Number
61/492,117

(32) Date
2011.06.01

(33) Country
US

(43) Publication Date: **2012.12.06**

(44) Accepted Journal Date: **2017.02.23**

(71) Applicant(s)
Martin Gorman

(72) Inventor(s)
Gorman, Martin N.

(74) Agent / Attorney
FB Rice, Level 23 44 Market Street, Sydney, NSW, 2000, AU

(56) Related Art
US 2009/0178684 A1
WO 2008/043132 A1
US 2009/0181071 A1



- (51) International Patent Classification:
A61F 5/56 (2006.01)
- (21) International Application Number:
PCT/US2012/040176
- (22) International Filing Date:
31 May 2012 (31.05.2012)
- (25) Filing Language: English
- (26) Publication Language: English
- (30) Priority Data:
61/492,117 1 June 2011 (01.06.2011) US
- (72) Inventor; and
- (71) Applicant : GORMAN, DDS, Martin N. [US/US];
17120 Otsego Street, Encino, California 91316 (US).
- (74) Agents: RAWLINS, Andrew, E. et al.; Foley & Lardner
LLP, 3000 K Street, NW, Suite 600, Washington, District
of Columbia 20007 (US).
- (81) Designated States (unless otherwise indicated, for every
kind of national protection available): AE, AG, AL, AM,

AO, AT, AU, AZ, BA, BB, BG, BH, BR, BW, BY, BZ, CA, CH, CL, CN, CO, CR, CU, CZ, DE, DK, DM, DO, DZ, EC, EE, EG, ES, FI, GB, GD, GE, GH, GM, GT, HN, HR, HU, ID, IL, IN, IS, JP, KE, KG, KM, KN, KP, KR, KZ, LA, LC, LK, LR, LS, LT, LU, LY, MA, MD, ME, MG, MK, MN, MW, MX, MY, MZ, NA, NG, NI, NO, NZ, OM, PE, PG, PH, PL, PT, QA, RO, RS, RU, RW, SC, SD, SE, SG, SK, SL, SM, ST, SV, SY, TH, TJ, TM, TN, TR, TT, TZ, UA, UG, US, UZ, VC, VN, ZA, ZM, ZW.

(84) Designated States (unless otherwise indicated, for every kind of regional protection available): ARIPO (BW, GH, GM, KE, LR, LS, MW, MZ, NA, RW, SD, SL, SZ, TZ, UG, ZM, ZW), Eurasian (AM, AZ, BY, KG, KZ, RU, TJ, TM), European (AL, AT, BE, BG, CH, CY, CZ, DE, DK, EE, ES, FI, FR, GB, GR, HR, HU, IE, IS, IT, LT, LU, LV, MC, MK, MT, NL, NO, PL, PT, RO, RS, SE, SI, SK, SM, TR), OAPI (BF, BJ, CF, CG, CI, CM, GA, GN, GQ, GW, ML, MR, NE, SN, TD, TG).

Published:
— with international search report (Art. 21(3))

(54) Title: DENTAL APPLIANCE

FIG. 3

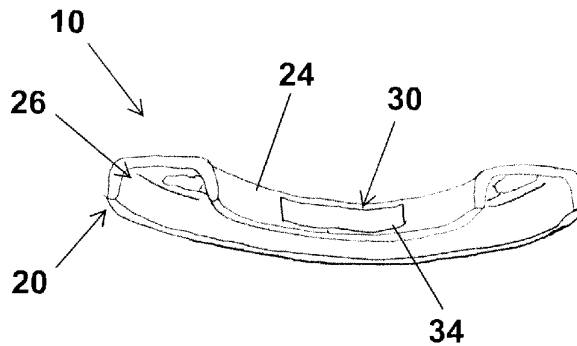

(57) Abstract: A dental appliance is provided. The dental appliance includes a dental form configured to receive a portion of a dental arch of an individual, and an adhesive strip comprising a first side and a second side. The first side of the adhesive strip is attached to a portion of the dental form. The second side of the adhesive strip comprises a mucoadhesive configured to adhere the adhesive strip to a tongue of the individual such that the tongue of the individual can be selectively attached to the dental appliance.

WO 2012/166896 A1

DENTAL APPLIANCE

CROSS-REFERENCE TO RELATED APPLICATIONS

[0001] This application claims priority from U.S. Provisional Patent Application No. 61/492,117, filed June 1, 2011, which is hereby incorporated by reference in its entirety.

FIELD OF THE INVENTION

[0002] The present invention relates generally to the field of dental appliances and, more particularly, to dentally retained intraoral appliances worn at night for treatment of snoring and obstructive sleep apnea.

BACKGROUND OF THE INVENTION

[0003] Obstructive sleep apnea is a serious and potentially lethal disorder characterized by abnormal pauses in breathing or instances of abnormally low breathing. Each pause in breathing, called an apnea, can last from a few seconds to several minutes, and may occur 5 to 30 times or more per hour. Individuals with sleep apnea can experience daytime fatigue, impaired reaction time and vision problems. Other effects include difficulty with information processing, judgment, and short term memory, all of which can severely interrupt daytime cognition. Behavioral effects, such as decreased motivation, moodiness, and aggressiveness may also accompany sleep apnea. The behavioral and cognitive effects of sleep apnea can be dangerous in many occupations especially manual labor and machine operating.

[0004] Snoring is the vibration of respiratory structures and the resulting sound, due to obstructed air movement during breathing while sleeping. In some cases the sound may be soft, but in other cases, it can be loud and unpleasant. Snoring, like sleep apnea, can cause sleep deprivation to snorers and those around them, as well as daytime drowsiness, irritability, and lack of focus.

[0005] Some studies reveal that habitual snoring and sleep apnea are associated with other potentially serious medical conditions, such as hypertension, ischemic heart disease, and strokes. Accordingly, early diagnosis and treatment is recommended.

[0006] Snoring and obstructive sleep apnea are typically caused by partial or complete obstruction of an individual's pharyngeal airway. Airway obstruction often results from the apposition of the rear portion of the tongue with the posterior pharyngeal wall.

[0007] One approach for the treatment of sleep apnea and snoring is the performance of a surgery called uvulopalatopharyngoplasty, which is a procedure used to remove tissue in the throat. For example, a portion of the soft palate may be removed to prevent closure of the pharyngeal airway during sleep. However, the operation is not always successful and can result in complications.

[0008] Many non-surgical approaches for the treatment of sleep apnea and snoring have been developed, some of which involve the use of intraoral dental appliances. For example, it is recognized that movement of the lower jaw forward relative to the upper jaw can help to reduce sleep apnea and snoring by causing the pharyngeal airway to remain open. Dental appliances have been developed which can be worn at night to maintain the upper and lower jaws in desired locations. Such appliances generally include orthodontic retainers or mouthguards that are custom-fit to an individual's upper (superior) and lower (inferior) dental arches.

[0009] While such dental appliances have proven effective in maintaining the lower jaw in a protruded position relative to the lower jaw, this position often results in serious discomfort in many individuals. The appliances are often bulky, invasive and constructing, and can cause pain in the jaw muscles. Use of such appliances can cause temporomandibular joint disorder (TMJ), an acute or chronic inflammation of the temporomandibular joint, which connects the mandible to the skull.

[0010] Therefore, there is a need for an improved dental appliance for treating sleep apnea and snoring.

[0010A] Any discussion of documents, acts, materials, devices, articles or the like which has been included in the present specification is not to be taken as an admission that any or all of these matters form part of the prior art base or were common general knowledge in the field relevant to the present disclosure as it existed before the priority date of each claim of this application.

SUMMARY OF THE INVENTION

[0010B] Throughout this specification the word "comprise", or variations such as "comprises" or "comprising", will be understood to imply the inclusion of a stated element, integer or step, or group of elements, integers or steps, but not the exclusion of any other element, integer or step, or group of elements, integers or steps.

[0010C] According to one aspect, there is provided a dental appliance for treatment of sleep apnea and snoring, the dental appliance comprising:

a dental form configured to receive a portion of a dental arch of an individual, the dental form including a rear exterior wall, and a front exterior wall opposing the rear exterior wall; and

an adhesive strip comprising a first side and a second side,

wherein the rear exterior wall of the dental form has an arch-shaped surface configured to extend along a rear of the dental arch of the individual,

wherein the first side of the adhesive strip is attached to the arch-shaped surface of the rear exterior wall of the dental form,

wherein the second side of the adhesive strip comprises a mucoadhesive configured to attach the adhesive strip to a tongue of the individual such that the tongue of the individual can be selectively attached to the dental form via the adhesive strip, and

wherein a rear-most portion of the arch-shaped surface of the rear exterior wall is a rear-most portion of the dental form.

[0010D] According to another aspect, there is provided a device for treatment of sleep apnea and snoring, the device comprising:

an adhesive strip comprising a first side and a second side, the adhesive strip extending in a linear manner from a first longitudinal end thereof to a second longitudinal end thereof,

wherein the first side of the adhesive strip comprises an adhesive configured to attach the adhesive strip to a dental form configured to receive a portion of a dental arch of an individual, and

wherein the second side of the adhesive strip comprises a mucoadhesive configured to attach the adhesive strip to a tongue of the individual such that the tongue of the individual can be selectively attached to the dental form.

[0010E] According to another aspect, there is provided a kit for treatment of sleep apnea and snoring, the kit comprising:

a dental form configured to receive a portion of a dental arch of an individual, the dental form including a rear exterior wall, and a front exterior wall opposing the rear exterior wall; and

at least one adhesive strip comprising a first side and a second side, wherein the rear exterior wall of the dental form has an arch-shaped surface configured to extend along a rear of the dental arch of the individual,

wherein the first side of the adhesive strip comprises an adhesive configured to attach the adhesive strip to the arch-shaped surface of the rear exterior wall of the dental form,

wherein the second side of the adhesive strip comprises a mucoadhesive configured to attach the adhesive strip to a tongue of the individual such that the tongue of the individual can be selectively attached to the dental form via the adhesive strip, and

wherein a rear-most portion of the arch-shaped surface of the rear exterior wall is a rear-most portion of the dental form.

[0010F] According to a further aspect, there is provided An adhesive strip for treatment of sleep apnea and snoring, the adhesive strip comprising:

a base strip made of a material consisting of only a synthetic moldable plastic material, the base strip having a first surface and a second surface opposing the first surface, and the base strip extending in a linear manner from a first longitudinal end thereof to a second longitudinal end thereof;

a first mucoadhesive disposed on the first surface of the base strip, the first mucoadhesive being configured to removably attach the base strip to teeth of an individual such that the adhesive strip can be selectively attached to the teeth of the individual; and

a second mucoadhesive disposed on the second surface of the base strip, the second mucoadhesive being configured to removably attach the base strip to a tongue of the individual such that the adhesive strip can be selectively attached to the tongue of the individual,

wherein the adhesive strip allows the tongue of the individual to be selectively attached to the teeth of the individual via the adhesive strip.

[0010G] According to yet another aspect, there is provided a method for treatment of sleep apnea and snoring, the method comprising:

providing an adhesive strip comprising a first side and a second side, wherein the first side of the adhesive strip comprises a first mucoadhesive configured to removably attach the adhesive strip to the teeth of an individual such that the adhesive strip can be selectively attached to the teeth, and wherein the second side of the adhesive strip comprises a second mucoadhesive configured to removably attach the adhesive strip to a tongue of the individual such that the tongue of the individual can be selectively attached to the teeth via the adhesive strip;

attaching the first side of the adhesive strip to the teeth of an individual via the first mucoadhesive, and attaching the second side of the adhesive strip to the tongue of the individual via the mucoadhesive, such that the tongue of the individual is attached to the teeth of the individual via the adhesive strip.

[0011] According to one embodiment, a dental appliance includes a dental form configured to receive a portion of a dental arch of an individual, and an adhesive strip comprising a first side and a second side. The first side of the adhesive strip is attached to a portion of the dental form. The second side of the adhesive strip comprises a mucoadhesive configured to adhere the adhesive strip to a tongue of the individual such that the tongue of the individual can be selectively attached to the dental appliance.

[0012] According to another embodiment, a device includes an adhesive strip comprising a first side and a second side. The first side of the adhesive strip comprises an adhesive configured to attach the adhesive strip to a dental form configured to receive a portion of a dental arch of an individual. The second side of the adhesive strip comprises a mucoadhesive configured to attach the adhesive strip to a tongue of the individual such that the tongue of the individual can be selectively attached to the dental form.

[0013] According to another embodiment, a kit includes a dental form configured to receive a portion of a dental arch of an individual, and at least one adhesive strip comprising a first side and a second side. The first side of the adhesive strip comprises an adhesive configured to attach the adhesive strip to a dental form configured to receive a portion of a dental arch of an individual. The second side of the adhesive strip comprises a mucoadhesive configured to attach the adhesive strip to a tongue of the individual such that the tongue of the individual can be selectively attached to the dental form.

[0014] According to another embodiment, a device includes an adhesive strip comprising a first side and a second side. The first side of the adhesive strip comprises a first mucoadhesive configured to attach the adhesive strip to the teeth or an individual such that the adhesive strip can be selectively attached to the teeth. The second side of the adhesive strip comprises a second mucoadhesive configured to attach the adhesive strip to a tongue of the individual such that the tongue of the individual can be selectively attached to the dental form.

[0015] According to another embodiment, a method includes providing an adhesive strip comprising a first side and a second side, wherein the first side of the adhesive strip comprises an adhesive, and wherein the second side of the adhesive strip comprises a mucoadhesive configured to removably attach the adhesive strip to a tongue of the individual such that the tongue of the individual can be selectively attached to the dental form. The method further includes attaching the first side of the adhesive strip to an item via the adhesive, the item being selected from the group consisting of a dental form, teeth of an individual, a device extending across the mouth of an individual, a mandibular advancement device, or a continuous positive airway pressure (CPAP) device. The method further includes attaching the second side of the adhesive strip to a tongue of the individual via the mucoadhesive.

BRIEF DESCRIPTION OF THE DRAWINGS

[0016] The accompanying drawings, which are incorporated in and constitute a part of this specification, illustrate various embodiments of the present invention, and together with the description, serve to explain the principles of the invention. In the drawings:

[0017] FIG. 1 is a bottom perspective view of a dental appliance according to an embodiment of the present invention.

[0018] FIG. 2 is a top view of dental appliance according to an embodiment of the present invention, showing a dental form having an adhesive strip on a portion thereof.

[0019] FIG. 3 is a rear perspective view of the dental appliance depicted in FIG. 2.

[0020] FIG. 4 is a side view of an adhesive strip of embodiments of the present invention.

[0021] FIG. 5 is a side cross-sectional view of a head of an individual with a partially obstructed pharyngeal airway.

[0022] FIG. 6 is a side cross-sectional view of a head of an individual using an embodiment of the dental appliance of the present invention.

DETAILED DESCRIPTION OF THE PREFERRED EMBODIMENTS

[0023] Embodiments of the disclosure will be described below with reference to the accompanying drawings. It should be understood that the following description is intended to describe exemplary embodiments, and not to limit the claimed subject matter.

[0024] Reference will now be made in detail to the present embodiments of the invention, examples of which are illustrated in the accompanying drawings. Wherever possible, the same reference numbers will be used throughout the drawings to refer to the same or like parts.

[0025] In an embodiment of the invention, depicted in FIGS. 1-3, a dental appliance 10 is provided. The dental appliance 10 includes a dental form 20 configured to receive a portion of a dental arch of an individual, and an adhesive strip 30 (see FIGS. 2 and 3) comprising a first side 32 and a second side 34. The first side 32 of the adhesive strip 30 is attached to a portion of the dental form 20. The second side 34 of the adhesive strip 30 comprises a mucoadhesive 35 (see FIG. 4) configured to adhere the adhesive strip 30 to a tongue of the individual such that the tongue of the individual can be selectively attached to the dental appliance 10.

[0026] The dental form 20 may have a front exterior wall 22 and a rear exterior wall 24. The dental form can be configured to receive a portion of the inferior dental arch and/or the superior dental arch of an individual. The rear exterior wall 24 is the wall that is on the tongue side of the dental form 20 if the dental form is configured to receive the inferior dental arch, and is on the palatal side of the dental form 20 if the dental form is configured to receive the superior dental arch. The front exterior wall 22 opposes the rear exterior wall. The dental form 20 is configured to receive the dental arch of an individual in a groove 26. The dental form 20 may be a custom dental form that is custom made for an individual using a mold of the superior or inferior dental arch of the individual. In this case, the dental form 20 may include a series of indentations 28 that match the shape of an individual's teeth, and thus provide them with a stable fitted surface. The dental form 20 may be thin, so as to provide comfort to an individual when using the dental appliance 10. For example, the dental form may have interior and exterior walls that have a thickness between 0.5 mm and 1.0 mm.

The dental form 20 may be transparent so as to be more aesthetically pleasing during use. The dental form 20 may be made of a plastic material, such as an acrylic resin. An example of a suitable acrylic resin is Biocryl™, manufactured by Great Lakes Orthodontics.

[0027] The dental form 20 may be formed using methods known in the art. For example, an impression of the superior or inferior dental arch of an individual may be made to create a mold. A thin plastic piece (for example, between 0.5 mm and 1.0 mm in thickness) may be heated and molded to match the impression of the dental arch using a vacuum machine, creating a custom dental form 20. The adhesive strip 30 may be attached to the dental form 20 on an appropriate portion of the dental form 20.

[0028] The dental appliance 10 includes an adhesive strip 30 having a first side 32 and a second side 34, as shown in FIG. 4. The adhesive strip 30 is attached to the dental form 20 on a portion of the dental form 20. The adhesive strip 30 may be attached to the dental form 20 on the rear exterior wall 24 of the dental form 20. The first side 32 of the adhesive strip 30 is coated with an adhesive 33. The adhesive 33 may be any adhesive that is appropriate to removably attach the adhesive strip 30 to the dental form 20. The adhesive 33 may removably attach the adhesive strip 30 such that the adhesive strip 30 remains connected to the dental form 20 while in use, but a user can remove the adhesive strip 30 from the dental form 20 when desired after use. The adhesive 33 may be, for example, an acrylic pressure-sensitive adhesive (PSA), a natural rubber PSA, a synthetic rubber PSA, or a UV curable PSA. Examples of synthetic rubber pressure-sensitive adhesives include those based on block copolymer rubbers, such as styrene-butadiene-styrene and styrene-isoprene-styrene; and those based on random copolymer rubbers such as styrene-butadiene-rubber. The adhesive 33 may be, for example, a synthetic rubber hydrocarbon resin that is latex free. The second side 34 of the adhesive strip 30 is coated with a mucoadhesive 35 that can attach the second side 34 of the adhesive strip 30 to the tongue of an individual. The mucoadhesive 35 removably attaches the adhesive strip 30 to the tongue such that the tongue will remain connected to the adhesive strip 30 while in use, but a user can remove the tongue from the adhesive strip 30 when desired after use. Examples of such mucoadhesives include cellulose based adhesives, chitosan, carboxyl methyl cellulose, hydroxypropyl methyl cellulose, and synthetic polypectins. The mucoadhesive 35 may include a material for absorbing moisture,

such as cellulose, sugars, starches, proteins. The mucoadhesive 35 may include a synthetic elastomeric block copolymer rubber PSA (such as SBS or SIS, discussed above). The mucoadhesive may also include a tackifying resin. The mucoadhesive 35 may be configured to remain active for between 6 and 10 hours, and preferably between 8 and 10 hours. The adhesive strip 30 may be designed to be changed daily by a user. The mucoadhesive 35 may be flavored. As an example, the mucoadhesive used in the PerioPatch[®], available from PeriZone[®], may be used in embodiments of the invention. This mucoadhesive includes ethylcellulose (a cellulosic), polyacrylic acid (a super-hydrophilic synthetic polymer), sambucus nigra, castor oil (an alcohol-based natural oil used as a carrier), acacia gum, methyl hydroxylpropyl cellulose (a cellulosic), glycerol (an alcohol carrier), centella asiatica, titanium dioxide (a white pigment), echinacea purpurea, and polysorbate 80 (a sugar-based surfactant), as well as flavoring.

[0029] The adhesive 33 and mucoadhesive 35 may be provided on a suitable base strip 39. The base strip 39 can be formed of a single layer or can be formed by multiple layers connected together. The base strip 39 may, for example, be a single layer made of a synthetic moldable plastic material that is latex free. The base strip 39 may be made of, for example, a polyester film, a mylar film, a water-soluble film (such as polyvinyl alcohol), or a non-woven/natural fabric material. The mucoadhesive 35 may be provided with a protective layer 37 over the mucoadhesive 35 to protect the mucoadhesive 35 until the dental appliance 10 is to be used. The protective layer may be made of, for example, a paper or polyester material coated with a release coating (typically a silicon based release coating). The adhesive strip 30 may have any shape suitable for attaching to the dental form 20. For example, the adhesive strip 30 may have a square or rectangular shape. The size of the adhesive strip 30 may depend on the dimensions of the dental arches and/or tongue of the individual using the dental appliance 10.

[0030] In an embodiment of the invention, the adhesive strip 30 may be attached to a projection that extends from a portion of the dental form 20. For example, the adhesive strip 30 may be attached to a projection configured so as to extend towards the back of an individual's throat when the dental form 20 is placed in the mouth of an individual.

[0031] In an embodiment of the invention, the adhesive strip 30 may be attached to a portion of a traditional mandibular advancement device or a portion of a continuous positive airway pressure (CPAP) device, rather than a dental form.

[0032] In another embodiment of the invention, the adhesive strip 30 may be attached to a device configured to extend across the mouth of an individual. For example, the adhesive strip 30 may be attached to a rubber band or another soft or hard device configured to extend across the mouth. The device may, for example, extend between two sides of a dental form. The adhesive strip 30 may be attached, for example, to a transpalatal bar or restrainer of the devices discussed in U.S. Patent No. 8,132,567 to Keropian, which is hereby incorporated by reference in its entirety. Use of the adhesive strip 30 can allow, for example, for use of a shortened restrainer, which can reduce the likelihood of gagging by reducing the extension of the restrainer into the throat.

[0033] In an embodiment of the invention, the adhesive strip 30 may be provided without being attached to a dental form 20, but can be configured to be used with an individual's existing intraoral dental appliance or dental form. The adhesive strip 30 may be provided with an adhesive 33 on the first side 32 of the adhesive strip 30 and a mucoadhesive 35 on the second side 34 of the adhesive strip 30. The adhesive 33 and mucoadhesive 35 may be provided on a suitable base strip 39. The adhesive 33 and mucoadhesive 35 may be provided with a protective layer 36 over the adhesive 33 and a protective layer 37 over the mucoadhesive 35, which can be removed by an individual before use of the adhesive strip 30. The individual can remove the protective layer 36 and attach the first side 32 of the adhesive strip 30 to an existing intraoral dental appliance or dental form (e.g., an existing retainer or mouthpiece). The individual may then remove the protective layer 37, place the existing dental appliance or dental form in the correct position in the mouth, and attach the tongue to the second side 34 of the adhesive strip 30.

[0034] In another embodiment of the invention, the adhesive strip 30 can be configured to be used without any dental appliance or dental form, i.e., the adhesive strip 30 can be configured to be connected to the tongue and directly to the teeth or other suitable portion of the person's mouth. In this configuration, preferably the adhesive 33 is replaced with an

additional mucoadhesive that is removably attachable directly to the teeth of an individual. The additional mucoadhesive can comprise the same materials as the mucoadhesive 35, which include cellulose based adhesives, chitosan, carboxyl methyl cellulose, hydroxypropyl methyl cellulose, and synthetic polypeptides. In this embodiment, the adhesive strip 30 has substantially the same configuration as that described in the preceding paragraph. The individual can remove the protective layer 37 from the mucoadhesive 35 and remove the protective layer 36 from the additional mucoadhesive. The individual can attach the first side 32 of the adhesive strip 30 directly to the teeth of the superior or inferior dental arch. The individual can then attach the tongue to the second side 34 of the adhesive strip 30. The adhesive strip 30 may comprise a first component strip forming the first side of the adhesive strip 30, and a second component strip forming the second side of the adhesive strip 30. The first component strip may comprise a first mucoadhesive, and the second component strip may comprise a second mucoadhesive, which is the same or different than the first mucoadhesive. The first component strip and the second component strip may be attached to one another via an adhesive. In other words, a double-sided mucoadhesive strip may be formed by attaching two single-sided mucoadhesive strips. For example, in this embodiment, the adhesive strip 30 may be made by joining two PerioPatch[®] devices to one another at their non-mucoadhesive sides.

[0035] In another embodiment of the invention, a kit is provided that includes both the dental form 20 and at least one adhesive strip 30 as described in the preceding paragraph.

[0036] Results that can be obtained by the dental appliance 10 are depicted in FIGS. 5 and 6. While the results are shown in conjunction with the dental appliance, it is expected that the same results can be achieved by using the adhesive strip 30 with an individual's existing intraoral dental appliance or dental form or by using the adhesive strip 30 alone. FIG. 5 depicts a cross section of the head of an individual with a partially obstructed pharyngeal airway 60. FIG. 5 shows the soft palate 40, uvula 50, posterior pharyngeal wall 70, upper jaw 90, superior dental arch 100, inferior dental arch 110, lower jaw 120, and tongue 130 of an individual. FIG. 5 shows the tongue 130 partially obstructing the pharyngeal airway 60 between the tongue 130 and the pharyngeal wall 70. The pharyngeal airway 60 is narrow in

the region 80, and the uvula 50 touches the tongue 130, both of which can cause sleep apnea and snoring.

[0037] FIG. 6 depicts a cross section of the head of an individual using the dental appliance 10. In FIG. 6, the dental appliance 10 is located on the inferior dental arch 110 of the individual. The tongue 130 adheres to the mucoadhesive 35 on the second side 34 of the adhesive strip 30. The dental appliance 10 can prevent the tongue 130 from collapsing backwards and blocking the pharyngeal airway 60 in the region 80, and can also prevent the uvula 50 from contacting the tongue 130, thus helping to treat sleep apnea and snoring. Because the dental appliance 10 is relatively thin, it allows a user to open and close the mouth and allows total freedom of movement of the jaw. While FIG. 6 shows the dental appliance 10 being used on the inferior dental arch 110, the dental appliance 10 can alternatively be provided on the superior dental arch 100, or the dental appliance 10 can be configured such that it is disposed on both the superior dental arch 100 and the inferior dental arch 110. For example, the dental appliance 10 may be provided on the superior dental arch 100 of an individual who normally breaths through the nose when sleeping. The dental appliance 10 may be provided on the inferior dental arch 110 of an individual who normally breaths through the mouth when sleeping.

[0038] While the preferred embodiments of the devices and methods have been described in reference to the environment in which they were developed, they are merely illustrative of the principles of the inventions. Modification or combinations of the above-described assemblies, other embodiments, configurations, and methods for carrying out the invention, and variations of aspects of the invention that are obvious to those of skill in the art are intended to be within the scope of the claims.

WHAT IS CLAIMED IS:

1. A dental appliance for treatment of sleep apnea and snoring, the dental appliance comprising:
 - a dental form configured to receive a portion of a dental arch of an individual, the dental form including a rear exterior wall, and a front exterior wall opposing the rear exterior wall; and
 - an adhesive strip comprising a first side and a second side, wherein the rear exterior wall of the dental form has an arch-shaped surface configured to extend along a rear of the dental arch of the individual, wherein the first side of the adhesive strip is attached to the arch-shaped surface of the rear exterior wall of the dental form, wherein the second side of the adhesive strip comprises a mucoadhesive configured to attach the adhesive strip to a tongue of the individual such that the tongue of the individual can be selectively attached to the dental form via the adhesive strip, and wherein a rear-most portion of the arch-shaped surface of the rear exterior wall is a rear-most portion of the dental form.
2. The dental appliance of claim 1, wherein the dental form is a custom dental form configured to receive a portion of a dental arch of a specific individual.
3. The dental appliance of claim 1 or 2, wherein the dental arch is a superior dental arch.
4. The dental appliance of claim 1 or 2, wherein the dental arch is an inferior dental arch.
5. The dental appliance of any one of the preceding claims, wherein the mucoadhesive is configured to remain active for a time between 8 and 10 hours.
6. The dental appliance of any one of the preceding claims, wherein the mucoadhesive comprises a material selected from the group consisting of a cellulose based adhesive, chitosan, carboxyl methyl cellulose, hydroxypropyl methyl cellulose, a synthetic polypectin, and combinations thereof.

7. A device for treatment of sleep apnea and snoring, the device comprising:
 - an adhesive strip comprising a first side and a second side, the adhesive strip extending in a linear manner from a first longitudinal end thereof to a second longitudinal end thereof,
 - wherein the first side of the adhesive strip comprises an adhesive configured to attach the adhesive strip to a dental form configured to receive a portion of a dental arch of an individual, and
 - wherein the second side of the adhesive strip comprises a mucoadhesive configured to attach the adhesive strip to a tongue of the individual such that the tongue of the individual can be selectively attached to the dental form.

8. A kit for treatment of sleep apnea and snoring, the kit comprising:
 - a dental form configured to receive a portion of a dental arch of an individual, the dental form including a rear exterior wall, and a front exterior wall opposing the rear exterior wall; and
 - at least one adhesive strip comprising a first side and a second side,
 - wherein the rear exterior wall of the dental form has an arch-shaped surface configured to extend along a rear of the dental arch of the individual,
 - wherein the first side of the adhesive strip comprises an adhesive configured to attach the adhesive strip to the arch-shaped surface of the rear exterior wall of the dental form,
 - wherein the second side of the adhesive strip comprises a mucoadhesive configured to attach the adhesive strip to a tongue of the individual such that the tongue of the individual can be selectively attached to the dental form via the adhesive strip, and
 - wherein a rear-most portion of the arch-shaped surface of the rear exterior wall is a rear-most portion of the dental form.

9. An adhesive strip for treatment of sleep apnea and snoring, the adhesive strip comprising:
 - a base strip made of a material consisting of only a synthetic moldable plastic material, the base strip having a first surface and a second surface opposing the first surface, and the base strip extending in a linear manner from a first longitudinal end thereof to a second longitudinal end thereof;
 - a first mucoadhesive disposed on the first surface of the base strip, the first mucoadhesive being configured to removably attach the base strip to teeth of an individual such that the adhesive strip can be selectively attached to the teeth of the individual; and

a second mucoadhesive disposed on the second surface of the base strip, the second mucoadhesive being configured to removably attach the base strip to a tongue of the individual such that the adhesive strip can be selectively attached to the tongue of the individual,

wherein the adhesive strip allows the tongue of the individual to be selectively attached to the teeth of the individual via the adhesive strip.

10. The device of claim 9, wherein the synthetic moldable plastic is a polyester film, a mylar film, or a polyvinyl alcohol film.

11. The device of claim 9 or 10, wherein the base strip is rectangular.

12. The device of any one of claims 9 to 11, wherein the first and second mucoadhesives are configured to remain active for a time between 8 and 10 hours.

13. The device of any one of claims 9 to 12, wherein the first and second mucoadhesives comprise a material selected from the group consisting of a cellulose based adhesive, chitosan, carboxyl methyl cellulose, hydroxypropyl methyl cellulose, a synthetic pectin, and combinations thereof.

14. The device of any one of claims 9 to 13, wherein the first mucoadhesive is the same as the second mucoadhesive.

15. A method for treatment of sleep apnea and snoring, the method comprising:
providing an adhesive strip comprising a first side and a second side, wherein the first side of the adhesive strip comprises a first mucoadhesive configured to removably attach the adhesive strip to the teeth of an individual such that the adhesive strip can be selectively attached to the teeth, and wherein the second side of the adhesive strip comprises a second mucoadhesive configured to removably attach the adhesive strip to a tongue of the individual such that the tongue of the individual can be selectively attached to the teeth via the adhesive strip;

attaching the first side of the adhesive strip to the teeth of an individual via the first mucoadhesive, and attaching the second side of the adhesive strip to the tongue of the individual via the mucoadhesive, such that the tongue of the individual is attached to the teeth of the individual via the adhesive strip.

FIG. 1

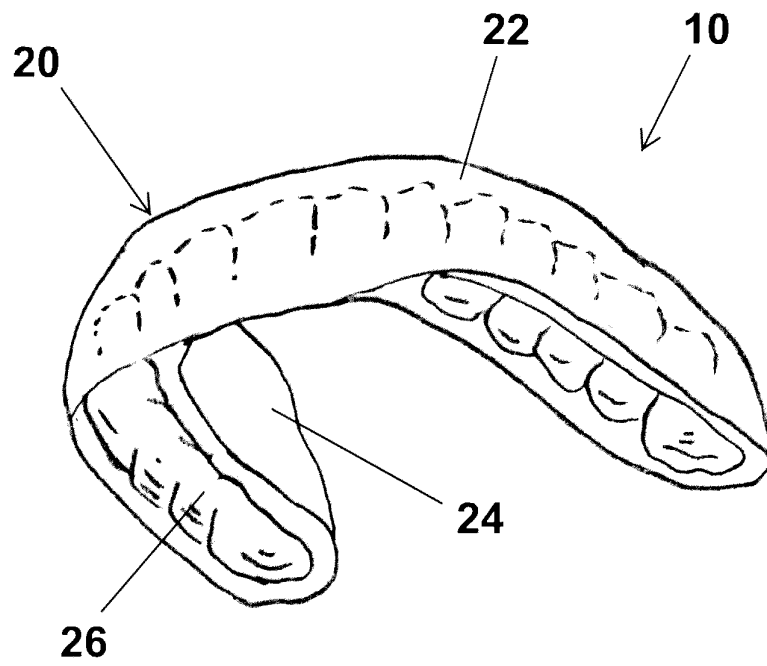

FIG. 2

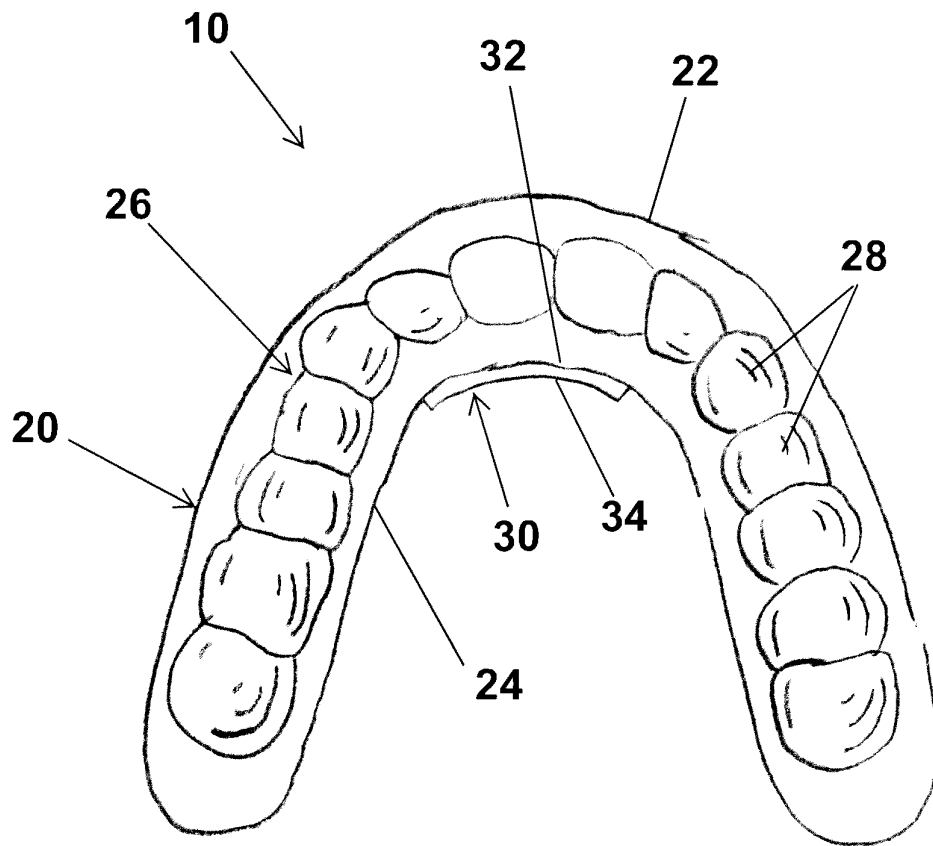

FIG. 3

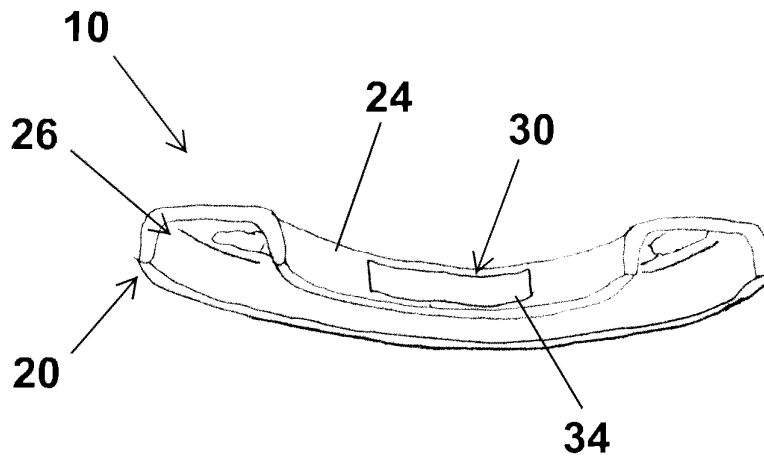

FIG. 4

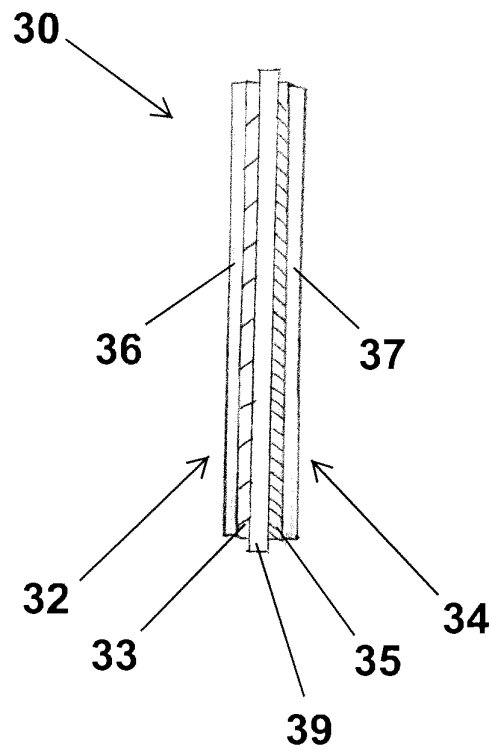

FIG. 5

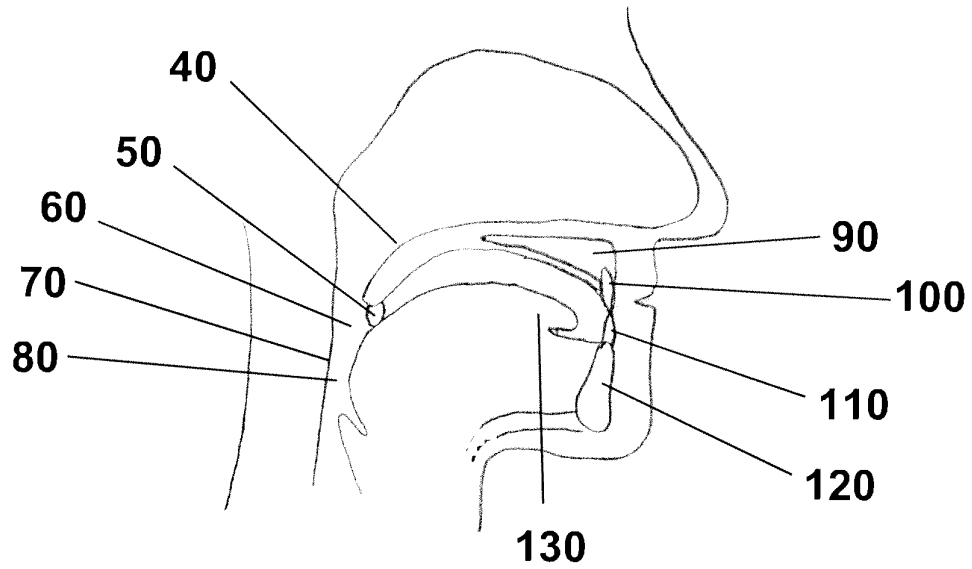

FIG. 6

