



(51) International Patent Classification:

A61B 17/11 (2006.01) A61F 2/07 (2013.01)
A61F 2/06 (2006.01) A61B 17/00 (2006.01)
A61F 2/90 (2013.01)

(21) International Application Number:

PCT/US2015/028711

(22) International Filing Date:

1 May 2015 (01.05.2015)

(25) Filing Language:

English

(26) Publication Language:

English

(30) Priority Data:

61/987,954 2 May 2014 (02.05.2014) US
14/700,427 30 April 2015 (30.04.2015) US

(71) Applicant: **W.L. GORE & ASSOCIATES, INC.**
[US/US]; 555 Paper Mill Road, Newark, DE 19711 (US).

(72) Inventors: **HOUGHTON, Michael, J.**; 1206 Virginia Avenue, Newark, DE 19711 (US). **SAMBANDAM, Sakthi**; 1709 Stone Gate Blvd., Elkton, MD 21921 (US).

WARNER, Clifford, P.; 1701 Waterglen Lane, West Chester, PA 19392 (US).

(74) Agents: **MILLER, Amy** et al.; W.L. Gore & Associates, Inc., 551 Paper Mill Road, P.O. Box 9206, Newark, DE 19714-9206 (US).

(81) Designated States (unless otherwise indicated, for every kind of national protection available): AE, AG, AL, AM, AO, AT, AU, AZ, BA, BB, BG, BH, BN, BR, BW, BY, BZ, CA, CH, CL, CN, CO, CR, CU, CZ, DE, DK, DM, DO, DZ, EC, EE, EG, ES, FI, GB, GD, GE, GH, GM, GT, HN, HR, HU, ID, IL, IN, IR, IS, JP, KE, KG, KN, KP, KR, KZ, LA, LC, LK, LR, LS, LU, LY, MA, MD, ME, MG, MK, MN, MW, MX, MY, MZ, NA, NG, NI, NO, NZ, OM, PA, PE, PG, PH, PL, PT, QA, RO, RS, RU, RW, SA, SC, SD, SE, SG, SK, SL, SM, ST, SV, SY, TH, TJ, TM, TN, TR, TT, TZ, UA, UG, US, UZ, VC, VN, ZA, ZM, ZW.

(84) Designated States (unless otherwise indicated, for every kind of regional protection available): ARIPO (BW, GH, GM, KE, LR, LS, MW, MZ, NA, RW, SD, SL, ST, SZ, TZ, UG, ZM, ZW), Eurasian (AM, AZ, BY, KG, KZ, RU, TJ, TM), European (AL, AT, BE, BG, CH, CY, CZ, DE,

[Continued on next page]

(54) Title: ANASTOMOSIS DEVICES

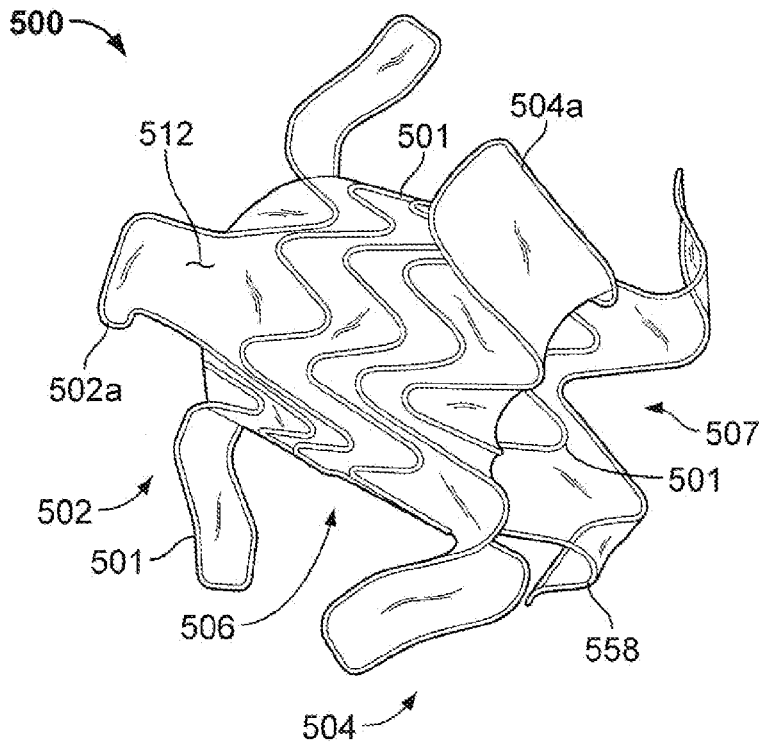

FIG. 2

(57) Abstract: Implantable medical devices for connecting tissue layers, such as for connecting a gallbladder and a portion of a gastrointestinal tract to create an anastomosis, include a tubular structure having two apposition portions, a central

[Continued on next page]





DK, EE, ES, FI, FR, GB, GR, HR, HU, IE, IS, IT, LT, LU, LV, MC, MK, MT, NL, NO, PL, PT, RO, RS, SE, SI, SK, SM, TR), OAPI (BF, BJ, CF, CG, CI, CM, GA, GN, GQ, GW, KM, ML, MR, NE, SN, TD, TG).

— before the expiration of the time limit for amending the claims and to be republished in the event of receipt of amendments (Rule 48.2(h))

Published:

— with international search report (Art. 21(3))

(88) Date of publication of the international search report:

24 March 2016

ANASTOMOSIS DEVICES

FIELD

[0001] The present disclosure relates generally to implantable medical devices, and more specifically, to implantable devices for connecting tissue layers to create an anastomosis. Methods for using the implantable medical devices are also disclosed.

BACKGROUND

[0002] An anastomosis is a cross-connection between two tissue structures, such as blood vessels or intestines. For example, in the context of coronary artery bypass graft surgery, a graft vessel is anastomosed to a native coronary artery so that blood can flow through the graft vessel.

[0003] Anastomoses can be created in various manners including, but not limited to: end-to-end, end-to-side, and side-to-side anastomoses. Often, suturing is used to create such anastomoses.

SUMMARY

[0004] One aspect of the invention relates to a medical device that includes (1) an expandable frame having a first end, a second end, and a middle portion between the first end and the second end, (2) a first apposition portion including a plurality of first apposition members, each of the first apposition members extending toward the middle portion, and (3) a second apposition portion including a plurality of second apposition members each of the second apposition members extending toward the middle portion. A first portion of each of the first apposition members may be oriented at a first angle in relation to a surface of the middle portion and a second portion of each the first apposition members may be oriented at a second angle in relation to the surface of the middle portion. In exemplary embodiments, the first angle is acute and is less than the second angle. Also, a first portion of each of the second apposition members may be oriented at a third angle in relation to the surface of the middle portion and a second portion of each of the second apposition members may be oriented at a fourth angle in relation to the surface of the middle portion. In exemplary embodiments, the third angle

is acute and is less than the fourth angle. In some embodiments, at least one of the first apposition members is longer than one or more others of the first apposition members. Additionally, at least one of the first apposition members may be longer than at least one of the second apposition members. In one or more embodiments, all of the first apposition members are longer than all of the second apposition members. The first apposition members may or may not be in axial alignment with the second apposition members. In another embodiment, one or more of the first apposition members may longitudinally overlap with one or more of the second apposition members. A cover material may be positioned on at least a portion of the frame.

[0005] A second aspect of the invention relates to a medical device that includes a frame including an elongate member defining (1) a first apposition portion that includes one or more first flange members configured to contact a first tissue surface and to provide an apposition force against the first tissue surface, (2) a second apposition portion that includes one or more second flange members configured to contact a second tissue surface and to provide an apposition force against the second tissue surface, and (3) a central portion having a first end and a second end where the central portion defines a longitudinal axis and the central portion is disposed between and interconnects the first apposition portion and the second apposition portion. In exemplary embodiments, at least one of the first flange members and at least one of the second flange members include a radius portion and a descending portion that extends longitudinally toward the central portion. At least one of the radius portions of the first flange members extends longitudinally beyond the first end and at least one of the radius portions of the second flange members extends longitudinally beyond the second end. In at least one embodiment, at least one of the first flange members or at least one of the second flange members further includes a horizontal portion that extends from the descending portion. The radius portions may extend from the first end or the second end of the central portion. Additionally, the descending portion may be a linearly descending portion. Further, the central portion may be configured to longitudinally extend and retract to maintain contact, over a range of tissue thicknesses,

of the first and second apposition portions with the first and second tissue surfaces, respectively.

[0006] A third aspect of the invention relates to a method of implanting an anastomosis device in a patient that includes (1) positioning a delivery sheath containing the anastomosis device at a target location within the patient and (2) deploying the anastomosis device out from the delivery sheath such that at least one layer of tissue is between a first apposition portion and a second apposition portion of the device. The anastomosis device includes (1) an expandable frame having a first end, a second end, and a middle portion between the first end and the second end, (2) a first apposition portion including a plurality of first apposition members, each of the first apposition members extending toward the middle portion, and (3) a second apposition portion including a plurality of second apposition members extending toward the middle portion. A first portion of each of the first apposition members may be oriented at a first angle in relation to a surface of the middle portion and a second portion of each the first apposition members may be oriented at a second angle in relation to the surface of the middle portion. In exemplary embodiments, the first angle is acute and is less than the second angle. Also, a first portion of each of the second apposition members may be oriented at a third angle in relation to the surface of the middle portion and a second portion of each of the second apposition members may be oriented at a fourth angle in relation to the surface of the middle portion. In exemplary embodiments, the third angle is acute and is less than the fourth angle. In at least one exemplary embodiment, a tip portion of the plurality of first apposition members or the plurality of second apposition members is spaced apart from the tissue. In other exemplary embodiments, two layers of tissue are between the first apposition portion and the second apposition portion.

DESCRIPTION OF DRAWINGS

[0007] The accompanying drawings are included to provide a further understanding of the disclosure and are incorporated in and constitute a part of this specification, illustrate embodiments, and together with the description serve to explain the principles of the disclosure.

[0008] FIG. 1 is a cutaway perspective view of an exemplary anastomosis device, that has been implanted within a patient to act as a shunt between the patient's gallbladder and intestine according to some embodiments;

[0009] FIG. 2 is a perspective view of an exemplary anastomosis device in accordance with some embodiments;

[0010] FIGS. 3-6 are perspective views of exemplary apposition members in accordance with some embodiments;

[0011] FIG. 7 is graphical illustration showing the relationship between force and displacement for each of the apposition members shown in FIGS. 3-6;

[0012] FIG. 8 is a schematic illustration of another exemplary anastomosis device in accordance with some embodiments;

[0013] FIG. 9 is a schematic illustration of exemplary apposition members in accordance with some embodiments;

[0014] FIG. 10 is a perspective view of yet another exemplary anastomosis device in accordance with some embodiments;

[0015] FIG. 11 is an end view of the anastomosis device of FIG. 10;

[0016] FIG. 12 is an alternative embodiment of the anastomosis device of FIG. 10; and

[0017] FIG. 13 is a side view of a central portion of another anastomosis device that includes expansion members in accordance with some embodiments.

DETAILED DESCRIPTION

[0018] Persons skilled in the art will readily appreciate that various aspects of the present disclosure can be realized by any number of methods and apparatus configured to perform the intended functions. It should also be noted that the accompanying

drawing figures referred to herein are not necessarily drawn to scale, but may be exaggerated to illustrate various aspects of the present disclosure, and in that regard, the drawing figures should not be construed as limiting.

[0019] The present invention is directed to implantable devices for connecting tissue layers, for example, to circumvent a conduit or organ blockage, such as by creating a direct passage between tissue structures (e.g. connecting a gallbladder and a portion of a gastrointestinal tract) to create an anastomosis that facilitates material flow therebetween. The devices described herein may be endoscopically deployable or deliverable via a catheter and may include self-expanding apposition mechanisms that facilitate a secure connection between the tissue structures (such a connection may also be referred to herein as a "shunt," "passageway," "shunt passageway," or "tunnel"). Such design features simplify implantation and reduce the likelihood of complications. In some embodiments, the devices provided herein are configured to be removable after implantation. As one example, the device is implanted and remains in place until the gallbladder and/or its associated ducts are cleared of blockages, after which the device is removed. In another example, the device remains implanted until the body grows a tissue-anastomosis around the device, and then the device is removed. In other embodiments, tissue ingrowth into and/or around the device permanently implants the device, and the device is not removed. The devices described herein can provide an alternative treatment for patients who are not suitable candidates for other types of treatments (e.g., gallbladder removal surgery) and/or to avoid known complications of other types of treatments (e.g., external biliary drainage).

[0020] This document refers to anastomosis devices in an exemplary fashion. That is, it should be understood that the inventive concepts disclosed in this document can also be applied to other types of devices. For example, this document also provides implantable devices that, in some embodiments, can be used for occluding tissue structures, organs, body conduits, blood vessels, the GI tract, and the like. For example, in some embodiments the devices provided herein can be used to occlude septal defects. In some embodiments, the devices provided herein can be used to occlude a patient's vasculature or GI tract. In some such embodiments, the device

does not include a tunnel through the device. Rather, in some embodiments a covering material seals the device to inhibit, modulate, or substantially prevent material from flowing through the device.

[0021] Referring to FIG. 1, an exemplary anastomosis device 40 in accordance with one or more provided herein can be implanted in a patient to create a fluidic connection between two organs, spaces, tissue structures, conduits, and the like, and combinations thereof. For example, in the depicted implementation the anastomosis device 40 is connecting a gallbladder 10 (that defines an internal gallbladder space 12) with an intestine 20 (that defines an internal intestinal space 22). Hence, the anastomosis device 40 is acting as a fluidic shunt device between the internal gallbladder space 12 and the internal intestinal space 22. Such an implementation may provide a beneficial treatment to the patient when, for example, a flow blockage exists in the native anatomical conduits connecting the internal gallbladder space 12 and the internal intestinal space 22. For example, in some instances the patient may have one or more gallstones that cause a blockage of the patient's cystic duct 14 and/or common bile duct 16. In such a case, the anastomosis device 40 can provide a fluidic passageway such that bile from the gallbladder 10 can flow into the intestine 20. If not for the anastomosis device 40, when bile is blocked from flowing out of the gallbladder 10 cholecystitis (inflammation of the gallbladder 10) may result.

[0022] While the anastomosis devices provided herein can be used in some implementations to relieve or prevent cholecystitis as described above, it should be understood that the anastomosis devices provided herein can also be used in many other types of implementations within a patient. For example, the anastomosis devices provided herein can be used in conjunction with various body tissue structures and organs such as, but not limited to, stomachs, colons, small intestines, pancreases, blood vessels, bladders, kidneys, conduits, and the like.

[0023] In general, some embodiments of the anastomosis devices provided herein (of which anastomosis device 40 is one type of example), include a first tissue apposition portion 42a, a second tissue apposition portion 42b, and a central portion 44

between the first and second tissue apposition portions 42a and 42b. The central portion 44 defines a lumen 46 that extends longitudinally from a first end of the anastomosis device 40 to a second end of the device 40. The lumen 46 acts as a connection (e.g., a shunt passageway) between the internal gallbladder space 12 and the internal intestinal space 22, such that the internal gallbladder space 12 is in fluid communication with the internal intestinal space 22 via the anastomosis device 40.

[0024] Referring to FIG. 2, an example anastomosis device 500 includes a framework of one or more elongate elements 501 that defines a first apposition portion 502, a second apposition portion 504, and a central portion 506 is depicted. The central portion 506 is disposed between and interconnects the first apposition portion 502 and the second apposition portion 504. In some embodiments, the central portion 506 is essentially cylindrical (although other geometries are also contemplated and are considered to be within the purview of the invention).

[0025] In some embodiments, a covering material 512 is disposed on at least some portions of the anastomosis device 500. As described further below, the covering material 512 can be disposed on some portions or on all of the first apposition portion 502, the second apposition portion 504, and/or the central portion 506. In some embodiments, portions of the first apposition portion 502, the second apposition portion 504, and/or the central portion 506 can remain free of the covering material 512.

[0026] In some embodiments, the central portion 506 defines a lumen 507 that extends between the first apposition portion 502 and the second apposition portion 504. In some implementations, the lumen 507 provides an anastomosis passageway or tunnel through which biological materials and/or fluids can pass. The device 500 is shown in an expanded configuration. The expanded configuration is the configuration that the device 500 naturally exhibits in the absence of external forces acting upon the device 500. It should be understood that when the anastomosis device 500 is implanted in a patient, the configuration of the device 500 may be somewhat different than shown because of the external forces from the patient's anatomy that are exerted on the device 500.

[0027] The anastomosis device 500 is shown in a deployed or expanded configuration. In some embodiments, the framework of the anastomosis device 500, as described further below, can be made of a variety of metallic shape memory materials and super-elastic alloys. Thus, in some embodiments the central portion 506 (and/or the apposition portions 502 and 504) can be configured to self-expand to the deployed configuration. In some embodiments, the central portion 506 is balloon expandable to the deployed configuration, or supplemental expansion forces can be applied to a self-expandable device by balloon dilation. The diameter of the central portion 506 can be made in any size as desired in order to suit the intended use and/or delivery system of the anastomosis device 500.

[0028] When the anastomosis device 500 is configured in its expanded deployed configuration as shown, the diameter of the central portion 506 increases to a deployed diameter. The diameter of the central portion 506 can be made in any dimension as desired in order to suit the intended use and/or delivery system of the anastomosis device 500. In some implementations, the deployed outer diameter of the central portion 506 is configured to at least partially anchor the device 500 via an interference fit with the tissue aperture in which the central portion 506 resides. Additionally, when the central portion 506 and the tissue aperture have an interference fit relationship, para-device leakage may be reduced or minimized. In such a case, leakage of the contents of the organs, conduits, and other types of tissue structures in which the anastomosis device 500 may be deployed can be substantially prevented. For example, when the anastomosis device 500 is used between a gallbladder and GI tract (e.g., refer to FIG. 1), leakage into the abdominal cavity can be substantially prevented.

[0029] In some implementations the deployed outer diameter of the central portion 506 is slightly less than the diameter of the tissue aperture in which the central portion 506 resides, and the apposition portions 502 and 504 compress the tissue to provide the migration resistance. In some embodiments, the fully expanded diameter of the central portion 506 is about 30 mm, or about 25 mm, or about 20 mm, or about 15 mm, or about 12 mm, or about 10 mm, or about 8 mm, or about 6 mm, or about 4 mm, and the like. In some embodiments, the fully expanded diameter of the central portion 506

is in a range between about 20 mm to about 30 mm, or about 15 mm to about 25 mm, or about 10 mm to about 20 mm, or about 5 mm to about 15 mm, or about 4 mm to about 8 mm, and the like.

[0030] The length of the central portion 506 can be made in any dimension as desired in order to suit the intended use and/or delivery system of the anastomosis device 500. For instance, in one exemplary embodiment the central portion 506 is about 13.5 mm in length and about 15 mm in diameter. In some embodiments, the length of the central portion 506 can be in a range from about 5 mm to about 10 mm, or about 8 mm to about 13 mm, or about 11 mm to about 16 mm, or about 14 mm to about 19 mm, or about 17 mm to about 22 mm, or greater than 22 mm.

[0031] In some embodiments, the anastomosis device 500 has a framework that comprises one or more elongate elements 501. In some embodiments, the one or more elongate elements 501 are wound into the framework configuration. In some embodiments, a single elongate element 501 is wound to form the framework of the anastomosis device 500. In some embodiments, two or more elongate elements 510 are cooperatively wound to form the framework of the anastomosis device 500.

[0032] In some embodiments, the framework of the first apposition portion 502, the second apposition portion 504, and the central portion 506 are formed of one or more elongate elements 501 made of materials such as, but not limited to, spring wire (e.g., L605 steel or stainless steels), shape memory alloy wire (e.g., nitinol or nitinol alloys), super-elastic alloy wire (e.g., nitinol or nitinol alloys), other suitable types of elongate elements or wires, or combinations thereof. In some embodiments, the first apposition portion 502, the second apposition portion 504, and the central portion 506 are formed from a precursor material that is cut to create the framework of elongate elements 501. In some such embodiments, the precursor material is a single piece of precursor material. In some embodiments, one or more elongate elements 501 are wound into a configuration to form the framework. In some embodiments, different types of elongate elements 501 are used at different locations of the first apposition portion 502, the second apposition portion 504, and/or the central portion 506. In some embodiments, the

elongate elements 501 of the first apposition portion 502, the second apposition portion 504, and/or the central portion 506 (or portions thereof) may be constructed of polymeric materials.

[0033] Suitable materials for the elongate elements 501 of the anastomosis device 500 and/or other devices provided herein include a variety of metallic materials including alloys exhibiting, shape memory, elastic and super-elastic characteristics. Shape memory refers to the ability of a material to revert to an originally memorized shape after plastic deformation by heating above a critical temperature. Elasticity is the ability of a material to deform under load and return to its original shape when the load is released. Most metals will deform elastically up to a small amount of strain. Super-elasticity refers to the ability of a material to deform under strain to much larger degree than typical elastic alloys, without having this deformation become permanent. For example, the super-elastic materials included in the frames of some anastomosis device embodiments provided herein are able to withstand a significant amount of bending and flexing and then return to or substantially to the frame's original form without deformation. In some embodiments, suitable elastic materials include various stainless steels which have been physically, chemically, and otherwise treated to produce a high springiness, metal alloys such as cobalt chrome alloys (e.g., ELGILOY™, MP35N, L605), platinum/tungsten alloys. Embodiments of shape memory and super-elastic alloys include the NiTi alloys, ternary shape memory alloys such as NiTiPt, NiTiCo, NiTiCr, or other shape memory alloys such as copper-based shape memory alloys. Additional materials could combine both shape memory and elastic alloys such as drawn filled tube where the outer layer is constructed of nitinol and the inner core is a radiopaque material such as platinum or tantalum. In this construct, the outer layer provides the super-elastic properties and the inner core remains elastic due to lower bending stresses.

[0034] In some embodiments, the elongate elements 501 used to construct the anastomosis device 500 and/or other devices provided herein can be treated in various ways to increase the radiopacity of the devices for enhanced radiographic visualization. In some embodiments, the devices are least partially a drawn-filled type of NiTi

containing a different material at the core, such as a material with enhanced radiopacity. In some embodiments, the devices include a radiopaque cladding or plating on at least portions of the first apposition portion, the second apposition portion, and the central portion. In some embodiments, one or more radiopaque markers are attached to the devices. In some embodiments, the elongate elements and/or other portions of the devices provided herein are also visible via ultrasound, and may include portions with enhanced echogenicity.

[0035] In some embodiments, the materials and configuration of the anastomosis device 500 (and the other anastomosis device embodiments provided herein) allow the devices to be elastically crushed, folded, and/or collapsed into a low-profile delivery configuration for containment within a lumen for transcatheter or endoscopic/thoroscopic delivery, and to self-expand to an operative size and configuration once positioned at a desired target site within a body and deployed from the lumen. For example, in the low-profile delivery configuration the anastomosis device 500 can be disposed within a delivery sheath that has about a 15 Fr. (5 mm) outer diameter. However, in some embodiments, sheaths that are smaller or larger than 15 Fr. can be used. For example, sheaths that have outer diameters of 6 Fr., 7 Fr., 8 Fr., 9 Fr., 10 Fr., 11 Fr., 12 Fr., 13 Fr., 14 Fr., 16 Fr., 17 Fr., 18 Fr., 19 Fr., 20 Fr., and larger than 20 Fr., can be used in some embodiments. While the anastomosis device 500 is configured in a collapsed delivery configuration, in some embodiments the framework of one or more elongate elements 501 is radially compressed such that the elongate elements 501 are forced to extend substantially parallel to axis of the central portion 506, and the diameter of the central portion 506 is crushed to become smaller.

[0036] The anastomosis device 500 also includes the covering material 512 (which may also be referred to herein as a "covering"). In some embodiments, the covering material 512 is disposed on at least some portions (or on all) of the first apposition portion 502, the second apposition portion 504, and the central portion 506. In some embodiments, some portions of the first apposition portion 502, the second apposition portion 504, and/or the central portion 506 are not covered by the covering material 512.

[0037] In some embodiments, the covering material 512 is generally fluid impermeable. That is, in some embodiments the covering material 512 is made of a material that inhibits or reduces passage of blood, bile and/or other bodily fluids and materials through the covering material 512 itself. In some embodiments, the covering material 512 has a material composition and configuration that inhibits or prevents tissue ingrowth and/or endothelialization or epithelialization into the covering material 512. Some such embodiments that are configured to inhibit or prevent tissue ingrowth and/or endothelialization can be more readily removed from the patient at a future date if so desired. In some embodiments, the covering material 512, or portions thereof, has a microporous structure that provides a tissue ingrowth scaffold for durable sealing and/or supplemental anchoring strength of the anastomosis device 500.

[0038] In some embodiments, the covering material 512 comprises a fluoropolymer, such as an expanded polytetrafluoroethylene (ePTFE) polymer, polyvinylidene fluoride (PVDF), or PVDA. In some embodiments, the covering material 512 comprises a polyester, a silicone, a urethane, biocompatible polymer(s), polyethylene terephthalate (e.g., Dacron®), bioabsorbable materials, copolymers, or combinations thereof. In some embodiments, the covering material 512 comprises a bioabsorbable web. In other embodiments, the bioabsorbable material may also provide an anti-migration feature by promoting attachment between the device 500 and tissue until the bioabsorbable material is absorbed.

[0039] In some embodiments, the covering material 512 (or portions thereof) is modified by one or more chemical or physical processes that enhance one or more properties of the material 512. For example, in some embodiments, a hydrophilic coating may be applied to the covering material 512 to improve the wettability and echo translucency of the material 512. In some embodiments, the covering material 512, or portions thereof, may be modified with chemical moieties that facilitate one or more of endothelial cell attachment, endothelial cell migration, endothelial cell proliferation, and resistance to or promotion of thrombosis. In some embodiments, the covering material 512, or portions thereof, may be modified to resist biofouling. In some embodiments, the covering material 512, or portions thereof, may be modified with one or more

covalently attached drug substances (e.g., heparin, antibiotics, and the like) or impregnated with the one or more drug substances. The drug substances can be released *in situ* to promote healing, reduce tissue inflammation, reduce or inhibit infections, and to promote various other therapeutic treatments and outcomes. In some embodiments, the drug substance may be, but is not limited to a corticosteroid, a human growth factor, an anti-mitotic agent, an antithrombotic agent, a stem cell material, or dexamethasone sodium phosphate. In some embodiments, a pharmacological agent is delivered separately from the covering material 512 to the target site to promote tissue healing or tissue growth.

[0040] Coatings and treatments may be applied to the covering material 512 before or after the covering material 512 is joined or disposed on or around the framework of the anastomosis device 500. Additionally, one or both sides of the covering material 512, or portions thereof, may be coated. In some embodiments, certain coatings and/or treatments are applied to the covering material(s) 512 located on some portions of the anastomosis device 500, and other coatings and/or treatments are applied to the material(s) 512 located on other portions of the anastomosis device 500. In some embodiments, a combination of multiple coatings and/or treatments are applied to the covering material 512, or portions thereof. In some embodiments, certain portions of the covering material 512 are left uncoated and/or untreated. In some embodiments, the device 500 is fully or partially coated to facilitate or frustrate a biological reaction, such as, but not limited to, endothelial cell attachment, endothelial cell migration, endothelial cell proliferation, and resistance to or promotion of thrombosis.

[0041] In some embodiments, a first portion of the covering material 512 is formed of a first material and a second portion of the covering material 512 is formed of a second material that is different than the first material. In some embodiments, the covering material 512 is comprised of multiple layers of materials, which may be the same or different materials. In some embodiments, portions of the covering material 512 have one or more radiopaque markers attached thereto to enhance *in vivo* radiographic visualization of the anastomosis device 500, or one or more echogenic areas to enhance ultrasonic visibility.

[0042] In some embodiments, one or more portions of the covering material 512 are attached to the framework of the device 500, such as the central portion 506 and/or the apposition portions 502 and 504. The attachment can be accomplished by a variety of techniques such as, but not limited to, stitching the covering material 512 to the framework of the device 500, adhering the covering material 512 to the framework of the device 500, laminating multiple layers of the covering material 512 to encompass portions of the elongate members of the device 500, using clips or barbs, laminating multiple layers of the covering material together through openings in the framework of the device 500. In some embodiments, the covering material 512 is attached to the framework of the device 500 at a series of discrete locations, thereby facilitating the flexibility of the framework. In some embodiments, the covering material 512 is loosely attached to the framework of the device 500. It is to be appreciated that the covering material 512 may be attached to the framework using other techniques or combinations of techniques described herein.

[0043] In some embodiments, the framework of the device 500 (or portions thereof) is coated with a bonding agent (e.g., fluorinated ethylene propylene or other suitable adhesive) to facilitate attachment of the covering material 512 to the framework. Such adhesives may be applied to the framework using contact coating, powder coating, dip coating, spray coating, or any other appropriate means.

[0044] The covering material 512 can adapt to changes in the length and/or diameter of the central portion 506 in a variety of manners. In a first example, the covering material 512 can be elastic such that the covering material 512 can stretch to accommodate changes in the length and/or diameter of the device 500. In a second example, the covering material can include slackened material in the low-profile delivery configuration that becomes less slackened or totally unslackened when the device 500 is in the expanded configuration. In a third example, the covering material 512 can include folded portions (e.g., pleats) that are folded in the low-profile configuration and less folded or totally unfolded when the device 500 is in the expanded configuration. In some embodiments, combinations of such techniques, and/or other techniques can be

used whereby the covering material 512 can adapt to changes in the length and/or diameter of the central portion 506.

[0045] The one or more elongate element(s) 501 of the central portion 506 can be configured in various ways to define a generally cylindrical framework. In the embodiment depicted in FIG. 2, the elongate element(s) 501 of the central portion 506 are wound circumferentially around the central portion 506. In addition to the circumferential winding, the elongate element(s) 501 can exhibit other winding paths, such as the wavy or serpentine path shown (e.g., approximately sinusoidal) and other paths. In the depicted embodiment, the winding path of the elongate element(s) 501 in the central portion 506 has eight apices per circumference, and an apical length of about 3.5 mm. In some embodiments, the elongate element(s) 501 of the central portion 506 can be made to have more or less than eight apices per circumference, and can be made to have an apical length of more than or less than 3.5 mm, as desired to suit a particular application. For example, in some embodiments the elongate element(s) 501 of the central portion 506 can be made to have three, four, five, six, seven, nine, ten, eleven, twelve, thirteen, fourteen, fifteen, sixteen, or more than sixteen apices per circumference. In some embodiments, the elongate element(s) 501 of the central portion 506 can be made to have an apical length in a range of about 1 mm to about 2 mm, or about 2 mm to about 3 mm, or about 3 mm to about 4 mm, or about 4 mm to about 5 mm, or about 5 mm to about 6 mm, or about 6 mm to about 7 mm, or greater than 7 mm.

[0046] In some embodiments, the apposition portions 502 and 504 include one or more flange components 502a and 504a, respectively. Such flange components (e.g., flange components 502a and 504a) may also be referred to herein as "fins," "petals," or "fingers." The flange components 502a and 504a are configured to contact tissues and to exert an apposition pressure thereto. While the depicted embodiment includes four flange components 502a and four flange components 504a, other quantities of flange components 502a and 504a can be included. For example, in some embodiments one, two, three, five, six, seven, eight, or more than eight flange components 502a and/or

504a may be included. In some embodiments, unequal numbers of flange components 502a and flange components 504a are included.

[0047] The flange components 502a and 504a can be configured to exert a predictable and desired apposition force when in contact with tissue. For example, the material(s), the diameter, and other properties of the elongate element can be selected to attain a desired apposition force. Elongate elements (e.g., nitinol elongate members) can be made to have a particular diameter as desired. Elongate elements made of other suitable materials and with larger or smaller diameters can be selected as desired. The geometry of the flange components 502a and 504a can also affect the apposition force exerted by the flange components 502a and 504a. That is, geometry aspects such as, but not limited to, the length, width, radii, angles, arcs (and the like) of the flange components 502a and/or 504a can be selected to attain a desired apposition force.

[0048] In some embodiments, the flange components 502a and 504a can be configured to have an offset orientation between the opposite end portions of the anastomosis device 500. That is, the axes of one or more of the individual flange components 502a may be offset (e.g., skewed, or out of alignment) from the axes of one or more of the individual flange components 504a. In some such embodiments, some or all of the flange components 502a and 504a can be configured to cross each other (e.g., overlap each other in an interposing arrangement). In some such embodiments, some or all of the flange components 502a and 504a may be offset from each other but not crossing each other. However, in some embodiments the axes of one or more of the individual flange components 502a may be generally in alignment (e.g., substantially parallel) with the axes of one or more of the individual flange components 504a. In some such embodiments, some or all of the flange components 502a and 504a can be configured to abut each other. In some such embodiments, some or all of the flange components 502a and 504a may be in alignment with each other but not abutting each other.

[0049] In some embodiments, one or more of the flange components 502a and/or 504a may vary in configuration in comparison to one or more others of the flange components 502a and/or 504a. For example, the flange components 502a can protrude farther towards the central portion 506 than the flange components 504a (or vice versa). Or, one or more of the flange components 502a or 504a can protrude farther towards the central portion 506 than others of the flange components 502a or 504a respectively.

[0050] In some embodiments, one or more of the flange components 502a and/or 504a may have two or more portions with differing curvatures (radii). For example, in the depicted embodiment, at least some of the flange components 502a and/or 504a extend from the central portion 506 at a first radius, and then straighten to a generally linear portion, and then curve along a second radius after which the flange components 502a and/or 504a terminate. In some embodiments, the first radius is unequal to the second radius. In some embodiments, the first and second radii are curved in opposite directions from each other.

[0051] In some embodiments, a radius 558 of the flange components 502a and 504a protrudes beyond the central portion 506 of the device. Therefore, the force applied by the flange components 502a and 504a may push some tissue into the radius 558, thereby making a longer and potentially stronger or less leak-prone anastomosis. In some embodiments, the radius 558 of curvature is determined by the allowed strain of the nitinol material when loaded into a delivery system (e.g., sheath). For example, in some embodiments a strain of about 6.4% may result. However, other strain levels of less than or more than about 6.4% are used in some embodiments.

[0052] In some implementations, including multiple flange components 502a and 504a may tend to reduce the potential for causing tissue ischemia. In some embodiments, individual flange components 502a are configured differently from each other, and/or individual flange components 504a are configured differently from each other. In some embodiments, the flange components 502a and 504a can remain discrete from each other (as shown), or in some embodiments the flange components

502a and 504a are interconnected to each other by, for example, the covering 512. In some embodiments, the flange components 502a and 504a can oppose or not oppose each other, can crisscross over each other, can have different geometries (e.g., lengths, widths, angles, radii, shapes, etc.). All combinations of such design features can be combined to create anastomosis devices of a wide variety of configurations. In some embodiments, one or both of the flange components 502a and 504a protrude from the central portion 506 at an axial orientation and shape to achieve a specific desired apposition pressure on the tissue.

[0053] In some embodiments, one or more of the shape of the flange components, the number of flange components, the elongate element size, and the tissue thickness are factors that are selectable to achieve a specific force profile vs. displacement. For example, referring to FIGS. 3–6, various exemplary flange component designs 510, 520, 530, and 540 are shown. The free ends shown in FIGS. 3–6 are where the flange components design 510, 520, 530, and 540 would extend from the device body (e.g., anastomosis device 500). The force vs. displacement curves for each is shown in FIG. 7.

[0054] The exemplary flange component 510 includes a sharply descending region 511 extending to the edge of the central portion (not shown), and a substantially horizontal region 513 extending away from the device. The exemplary flange component 520 includes a moderately sharp descending region 514 connected to and a sloping region 515 extending away from the device. The exemplary flange component 520 includes a linearly descending region 522 extending away from the device. The exemplary flange component 530 includes a gradual sloping curved region 532 extending away from the device. In some embodiments, one or more regions of the flange components longitudinally extend towards the central portion of the device of which the flange components are part of (e.g., towards central portion 506 of anastomosis device 500).

[0055] Particular flange component force vs. displacement profiles (e.g., flange components 510, 520, 530, and 540) may be advantageous for achieving a desired apposition pressure and/or other performance characteristics. For example, referring to FIG. 7, a graph of force vs. displacement shows the apposition force that can be applied by each flange component 510 (510f), 520 (520f), 530 (530f), and 540 (540f). The force vs. displacement profile of flange component 510 can include a steep linear slope, as shown by 510f. Curve 510f may be of particular benefit if the organs to be apposed are not close together. The linear and quickly increasing force would resist separation of the organs. In some embodiments, the force vs. displacement profile of flange component 520 can include a shallow linear slope that abruptly changes to a steep linear slope (520f). Curve 520f may be of particular benefit for creating high apposition force during the initial healing phase while the anastomosis is being created. During this time the tissue may be thicker and inflamed utilizing the steep linear profile of 520f. As the tissue inflammation and resulting tissue thickness reduced, the shallow part of curve 520f would be employed helping to avoid necrosis of the tissue. The force vs. displacement profile of flange component 530 produces a shallow linear slope (530f). Curve 530f provides a shallow linear increase in force with respect to displacement and may be particularly useful for tissue that is considered friable and prone to perforation. In other embodiments, the force vs. displacement profile of flange component 540 can include a continuously increasing slope (540f). Such variations of flange components (and other variations also contemplated within the scope of this disclosure) can be selected for a particular application as desired. For example, the force vs. displacement curve achieved by flange component 540 may be advantageous in particular applications because the curve smoothly increases and the design allows for a broad area of contact over a large range of displacement.

[0056] FIGS. 8 and 9 illustrate another example anastomosis device 1200. Anastomosis device 1200 is an example variation of the anastomosis device 500 described above. In particular, the anastomosis device 1200 has first and second apposition portions 1202 and 1204 that are designed differently than the first and second apposition portions 502 and 504 of anastomosis device 500. As described

further below, the one or more apposition members 1208 and 1210 that make up the first and second apposition portions 1202 and 1204 can be configured to provide functional properties that are desirable in some implementations.

[0057] In some embodiments, the framework of the device 1200 or any portion thereof can comprise elongate elements such as a spring wire (e.g., L605 steel or stainless steels), shape memory alloy wire (e.g., nitinol or nitinol alloys), super-elastic alloy wire (e.g., nitinol or nitinol alloys), other suitable types of wire, or combinations thereof. In the depicted embodiment of device 1200, the framework includes an elongate element that is formed by winding, for example. In some embodiments, different types of wires are used at different locations of the device 1200. Alternatively, device 1200 or portions thereof can be formed from the same piece of precursor material that is cut to create the elongate element framework structure as desired. In some embodiments, the device 1200 or portions thereof may be constructed of polymeric materials. The device 1200 is shown with a covering material, as described above. It should be understood that anastomosis device 1200 can be constructed using any of the materials and techniques described in reference to any and all other anastomosis devices described herein.

[0058] The central portion 1206 of the device can be constructed to have a tailored radial strength by, for example, varying the elongate element's sine wave amplitude, angle, number of apices per row, number of rows, wire diameter, and by selecting (or not selecting) a covering material. For anastomosis device applications, the radial strength of the central portion 1206 may be designed to resist circumferential loading from the surrounding tissue. Therefore, in some embodiments the radial strength of the central portion 1206 is configured to facilitate remodeling of the tissue external to the central portion 1206 to become approximate in size to the outer diameter of the central portion 1206. When the anastomosis device 1200 (and the other anastomosis devices provided herein) is implanted to form an anastomosis, the radial strength of the central portion 1206 provides resistance to the hoop force applied by the surrounding tissue. Therefore, an anastomosis device with strong radial strength in the central portion (e.g., central portion 1206) will substantially maintain an open lumen at a desired dimension.

In addition, a device with strong radial strength can advantageously act as a scaffold for tissue to grow around the device.

[0059] In some embodiments, the materials and configuration of the anastomosis device 1200 allow the device 1200 to be elastically crushed, folded, and/or collapsed into a low-profile configuration for containment within a lumen for transcatheter or endoscopic/thoroscopic delivery, and to self-expand to an operative size and configuration once positioned at a desired target site within a body and deployed from the lumen.

[0060] The first apposition portion 1202 and the second apposition portion 1204 are configured to engage one or more layers of tissue between the first and second apposition portions 1202 and 1204, and to provide apposition forces against the tissue surfaces. The apposition forces provided by the first and second apposition portions 1202 and 1204 can facilitate fixation of the device 1200 to the tissue, and provide migration resistance such that the device 1200 can reliably remain positioned at a target site in a patient as desired.

[0061] The first apposition portion 1202 and the second apposition portion 1204 each include one or more apposition members 1208 and 1210 respectively. The anastomosis device 1200 can be configured in a collapsed low-profile delivery configuration in which the apposition members 1208 and 1210 are radially compressed such that they extend substantially parallel to the longitudinal axis of the device. In the deployed or expanded configuration, the apposition members 1208 and 1210 protrude outwardly from the central portion 1206.

[0062] In some embodiments, at least one of the apposition members 1208 and/or 1210 is orientated to have a first angle 1216 in relation to the central portion 1206 and to have a second angle 1214 in relation to the central portion 1206 (as shown in FIG. 9). In other words, in some embodiments at least one apposition member 1208 and/or 1210 is non-planar. In the depicted embodiment the apposition member 1210 is orientated at a first angle 1216 in relation to the central portion 1206, and the apposition member 1210 is also oriented at a second angle 1214 in relation to the central portion

1206. In some embodiments, the first angle 1216 is a shallow angle. For example, in some embodiments the angle 1216 is acute, e.g., less than about 90°, or less than about 75°, or less than about 60°, or less than about 45°, or less than about 30°, or less than about 25°, or less than about 20°, or less than about 15°, or less than about 10°, or less than about 5°. In some embodiments, the angle 1216 is between about 15° and about 20°, or between about 10° and about 30°, or between about 5° and about 45°.

[0063] Because in some embodiments the angle 1216 is relatively shallow, and because the apposition member 1210 extends towards the central portion 1206, a portion of the apposition member 1210 is therefore orientated relatively close to the access location (i.e., the incision location in which the anastomosis device 1200 will be deployed). Hence, this configuration facilitates an effective and sustainable apposition of tissue.

[0064] In some embodiments, the second angle 1214 is a larger angle than the first angle 1216. For example, in some embodiments the angle 1214 is greater than about 90°, less than about 45°, less than about 25°, less than about 20°, less than about 15°, less than about 10°, or less than about 5°. In some embodiments, the angle 1214 is between about 30° and about 40°, or about 20° and about 45°, or about 30° and about 50°, or about 40° and about 60°, or about 50° and about 70°, or about 60° and about 80°, or about 70° and about 90°. In some embodiments the second angle 1214 is larger than the first angle 1216 such that a portion of the apposition member is orientated farther away from the access location. While, the shallow angle of the first angle 1216 permits tissue contact resulting in apposition force near the access location, the larger angle of the second angle 1214 permits tissue contact away from the access location, providing anti-migration forces to keep the device 1200 in place. Moreover, in some embodiments the larger angle of the second angle 1214 permits the terminal ends of the apposition members 1208 and/or 1210 to be out of contact with tissue *in situ*. In some such implementations, by having fins pointing away from the apposed tissue, the potential for tissue over-growth on fins can be delayed or avoided. By delaying or avoiding tissue overgrowth the device can be easily removed when/if needed. In some

embodiments, a single apposition member of this design can provide the benefits that are associated with having dual length apposition members.

[0065] In some embodiments, the apposition members 1208 and 1210 are in axial alignment with each other such that the positions of the apposition members 1208 and 1210 around the periphery of the central portion 1206 longitudinally coincide with each other. In some embodiments, the apposition members 1208 and 1210 are out of axial alignment with each other such that the positions of the apposition members 1208 and 1210 around the periphery of the central portion 1206 do not longitudinally coincide with each other. In some such embodiments, one or more of the apposition members 1208 of the first apposition portion 1202 longitudinally overlap (e.g., criss-crossed in an interposing arrangement) with one or more of the apposition members 1210 of the second apposition portion 1204, as depicted in FIGS. 8 and 9. In some embodiments, some or all of the apposition members 1208 and 1210 may be offset from each other, or in alignment with each other, while not crossing each other. In some embodiments, some or all of the apposition members 1208 and 1210 may be in alignment with each other and abutting each other.

[0066] Referring to FIGS. 10–12, an anastomosis device 1300 is shown having a central portion 1306 that is interchangeable with any other central portion described herein, a first apposition portion 1302, and a second apposition portion 1304. In some embodiments, the framework of device 1300 or any portion thereof can comprise one or more elongate elements such as a spring wire (e.g., L605 steel or stainless steels), shape memory alloy wire (e.g., nitinol or nitinol alloys), super-elastic alloy wire (e.g., nitinol or nitinol alloys), other suitable types of wire, or combinations thereof (as described above in reference to elongate element 501).

[0067] In the depicted embodiment of device 1300, the framework is comprised of a single elongate element that is formed by winding and shape-setting, for example. In some embodiments, different types of elongate elements are used at different locations of the device 1300. Alternatively, the anastomosis device 1300 (or portions thereof) can be formed from the same piece of precursor material that is cut and expanded to create

the elongate element framework structure as desired. In some embodiments, the device 1300 (or portions thereof) may be constructed of polymeric materials. It should be understood that anastomosis device 1300 can be constructed using any of the materials and techniques described in reference to any and all other anastomosis devices described herein.

[0068] In some embodiments, the framework of the central portion 1306 can be configured such that the central portion 1306 is longitudinally extendable. For example, in the depicted embodiment of anastomosis device 1300 the framework of the central portion 1306 includes serpentine-wound portions that allow for longitudinal extension and retraction (like a spring). Accordingly, the longitudinal length of the central portion 1306 can self-adjust based on *in vivo* loading forces. This feature can be advantageous, for example, in maintaining apposition when the tissue thickness changes during the healing process (e.g., in at least some cases of acute cholecystitis). It should be understood that this feature can be incorporated into any of the device embodiments described herein.

[0069] The device 1300 may include a covering material 1312. In some embodiments, the covering 1312 is made of stretchable (elastic-like) material that can have a high percentage of recoverable strain (e.g., recoverable strain in the magnitude of 100s of percentage per unit length). Some embodiments of such covering materials may include, but are not limited to, pure silicone, urethane material, or such materials that are imbedded in or laminated to other materials including, but not limited to, fluoropolymers such as ePTFE. In some embodiments, the covering material 1312 is as described herein (e.g., similar or identical to covering material 512).

[0070] The first apposition portion 1302 and the second apposition portion 1304 are configured to engage one or more layers of tissue between the first and second apposition portions 1302 and 1304, and to provide apposition forces against the tissue surfaces. The apposition forces provided by the first and second apposition portions 1302 and 1304 can facilitate attachment of the device 1300 to the tissue and provide

displacement resistance such that the device 1300 can reliably remain positioned at a target site in a patient as desired.

[0071] The first apposition portion 1302 and the second apposition portion 1304 each include one or more apposition members 1302a or 1302a' and 1304a or 1304a' (also referred to herein as anchor members, fins, flange portions, petals, etc.). In some embodiments, the apposition members 1302a and 1304a are bare elongate elements (without a covering). In some embodiments, the apposition members 1302a' and 1304a' have the covering material 1312 disposed on at least some areas of their elongate elements.

[0072] In some embodiments, one or more of the apposition members 1302a or 1302a' and/or 1304a or 1304a' have different configurations (e.g., geometries, lengths, widths, shapes, etc.) than one or more other apposition members 1302a or 1302a' and/or 1304a or 1304a'.

[0073] In some embodiments, the materials of the anastomosis device 1300 allow the device 1300 to be elastically crushed, folded, and/or collapsed into a low-profile configuration for containment within a lumen for transcatheter or endoscopic/thorascopic delivery, and to self-expand to an operative size and configuration once positioned at a desired target site within a body and deployed from the lumen. For example, the anastomosis device 1300 can be configured in a collapsed delivery configuration in which the framework is compressed to a low-profile such that the apposition members 1302a or 1302a' and 1304a or 1304a' extend substantially parallel to the longitudinal axis of the device 1300. In the deployed or expanded configuration, the apposition members 1302a or 1302a' and 1304a or 1304a' extend outwardly from the central portion 1306.

[0074] In some embodiments, the lengths of some of the apposition members 1302a or 1302a' and 1304a or 1304a' are dissimilar to provide both sufficient apposition forces near the periphery of the access location or hole where access is created, and anti-migration forces farther away therefrom. For example, in some embodiments one or more of the apposition members 1302a or 1302a' is longer than one or more of the

apposition members 1304a or 1304a'. In some embodiments, the apposition members 1302a or 1302a' and/or 1304a or 1304a' have varying lengths and are alternated, or arranged around the periphery of the first apposition portion 1302 and/or the second apposition portion 1304 in a pattern. In some embodiments, the apposition members 1302a or 1302a' and/or 1304a or 1304a' within each apposition portion 1102 and/or 1104 are uniform in length.

[0075] In some embodiments, the apposition members 1302a or 1302a' and/or 1304a or 1304a' have lengths that are selected based at least in part on the size of tissue structures that the device 1300 is to be implanted into. For example, if a first tissue structure generally includes smaller geometry than the second tissue structure, having differing lengths of the apposition members 1302a or 1302a' versus 1304a or 1304a' can be advantageous. In this example, the apposition portion entering the smaller tissue structure may beneficially have apposition members with a shorter length, while longer apposition members may be better-suited in the larger tissue structure. In some such implementations, the shorter length apposition members provide an appropriate fit for the smaller tissue structure thus ensuring sufficient tissue contact necessary for an anastomosis device, while the longer apposition members provide anti-migratory forces that help to retain the device in place. In some embodiments, such short and long apposition members 1302a or 1302a' and/or 1304a or 1304a' are staggered, nested, or separated around a periphery of a particular apposition portion 1302 and/or 1304.

[0076] The anastomosis device 1300 (and other embodiments that share design features of the anastomosis device 1300) can exhibit the following advantages. Having varying lengths of apposition members 1302a or 1302a' and/or 1304a or 1304a' can provide apposition at various target tissue locations. Having one or more such specific apposition zones may minimize or eliminate leakage of fluid or other contents that pass through the device lumen. Discrete apposition members 1302a or 1302a' and/or 1304a or 1304a' that move independently of each other can provide advantageous apposition member conformability to non-planar tissue topography. Better conformability can minimize tissue injury especially when used in a diseased tissue bed. The flexible

discrete design of the apposition members 1302a or 1302a' and/or 1304a or 1304a' can facilitate device 1300 removal by folding the apposition members 1302a or 1302a' and/or 1304a or 1304a' parallel to the lumen of the device 1300. This flexibility of the apposition members 1302a or 1302a' and/or 1304a or 1304a' may help to minimize tissue injury during removal of the anastomosis device 1300.

[0077] Referring to FIG. 13, another example central portion 206 can be included as part of any the anastomosis devices provided herein. As with the central portions 506, 1206, and 1306, the central portion 206 is comprised of a framework of one or more elongate elements. For enhanced visibility, the central portion 206 is shown without a covering material, however the covering material(s) described elsewhere herein can be applied to the central portion 206 in some embodiments. In this example, the central portion 206 is shown in an undeployed or low-profile delivery configuration. When deployed in a patient, the central portion 206 can self-expand or be forced to expand to an expanded configuration.

[0078] The one or more elongate elements of the central portion 206 can be constructed from the same types of materials and can be constructed using the same types of techniques as described above in reference to the elongate elements of anastomosis device 500. In some embodiments, the central portion 210 is formed by one or more wound wires. In some embodiments, the central portion 206 is formed from a unitary piece of precursor material that is cut to create the elongate element framework structure as desired. In some such embodiments, the precursor material is a tube (e.g., a nitinol tube) that is laser cut to form the desired elongate element framework structure. In some such embodiments, the precursor material is a sheet (e.g., a nitinol sheet) that is laser cut to form the desired elongate element framework structure. In some embodiments, different types of elongate elements are used at different portions of the central portion 206. For example, in some embodiments the central portion 206 or portions thereof may be constructed of polymeric materials.

[0079] The central portion 206 includes one or more axial adjustment members 218 extending along the longitudinal axis of the central portion 206. The axial adjustment members 218 allow the axial length (also referred to herein as "longitudinal length") of the central portion 206 to elastically extend or contract (as described above in reference to the framework of the central portion 1306 of anastomosis device 1300).

[0080] The central portion 206 also includes one or more cells 212. In some embodiments, the one or more cells 212 interconnect the axial adjustment members 218. The cells 212 allow for the radial expansion and contraction of the central portion 206, and provide radial strength to the device to maintain its shape/size while resisting external compression forces. During radial expansion of the central portion 206, the cells 212 expand in the circumferential direction and collapse in the longitudinal direction. While the cells 212 are shown as having a diamond-like shape, other geometries may be used. In the depicted embodiment, pairs of cells 212 are interconnected to each other in the circumferential direction by a bridge member 213. However, in some embodiments a single cell 212, or more than two cells 212, may be included (rather than the pair shown).

[0081] In some embodiments, the cells 212 are unconnected to adjacent cells 212 along the longitudinal axis of the central portion 206. As such, the cells 212 connecting to the axial adjustment members 218 do not substantially constrain the axial expansion or contraction of the axial adjustment members 218 and/or the central portion 206. In some embodiments, the cells 212 provide radial strength to the central portion 206. That is, in some embodiments the cells 212 tend to self-expand into an expanded configuration. Such self-expansion can provide radial forces from the central portion 206 to the tissues in that are contacted by the central portion 206.

[0082] In some embodiments, axial length of the central portion 206 is adjusted before or during deployment, e.g., by a clinician to accommodate differences in tissue thicknesses. In other embodiments, the axial adjustment member 218 self-responds to mechanical forces exerted on the deployed anastomosis device *in situ*. For example, the axial adjustment member 218 permits the axial length of the device to dynamically

adjust during the healing process (as described above in reference to central portion 1306).

[0083] The anastomosis devices provided herein are deployable to a target site within a patient using one or more catheters, delivery sheaths, and other suitable devices and techniques. In some implementations, the anastomosis devices provided herein are deployable using an endoscopic or laparoscopic approach.

[0084] It should be understood that one or more design features of the anastomosis devices provided herein can be combined with other features of other anastomosis devices provided herein. In effect, hybrid designs that combine various features from two or more of the anastomosis device designs provided herein can be created, and are within the scope of this disclosure.

[0085] In some such embodiments, the device does not include a tunnel or central aperture through the device.

[0086] In some embodiments the devices provided herein can be used for sealing or anchoring a heart valve implant. A heart valve implant enables one-way flow of blood from a heart chamber and usually has a first inflow end and a second outflow end. The contractions of the heart cause flow of blood through the valve from the inflow end to the outflow end. Between the inflow and outflow ends, a valve assembly within the heart valve implant provides for one way flow, opening to allow flow from the inflow to the outflow end when the pressure of the blood is higher on the inflow end, and closing to prevent flow when the pressure on the outflow end is higher than the inflow end. In some embodiments, the device includes a tunnel or central aperture through the device with apposition portions to anchor a valve assembly and seal against backward flow. A valve assembly can be attached in the tunnel or central aperture. The apposition portions of the device can be configured to be highly conformable to the topography of the heart chambers or blood vessels, and compliant with the beating movements of the heart. In some embodiments, a covering material is configured to allow flow through a valve assembly in the tunnel or aperture while preventing flow around the apposition portions.

[0087] The invention of this application has been described above both generically and with regard to specific embodiments. It will be apparent to those skilled in the art that various modifications and variations can be made in the embodiments without departing from the scope of the disclosure. Thus, it is intended that the embodiments cover the modifications and variations of this invention provided they come within the scope of the appended claims and their equivalents.

WHAT IS CLAIMED IS:

1. A medical device comprising:

an expandable frame having a first end, a second end, and a middle portion between said first end and said second end;

a first apposition portion comprising a plurality of first apposition members, each of said first apposition members extending toward said middle portion, a first portion of each said first apposition members being oriented at a first angle in relation to a surface of said middle portion, a second portion of each said first apposition member being oriented at a second angle in relation to said surface of said middle portion, wherein said first angle is acute and is less than said second angle; and

a second apposition portion comprising a plurality of second apposition members, each of said second apposition member extending toward said middle portion, a first portion of each said first apposition members being oriented at a third angle in relation to said surface of said middle portion, a second portion of each said second apposition members being oriented at a fourth angle in relation to said surface of said middle portion, wherein said third angle is acute and is less than said fourth angle.

2. The device of claim 1, further comprising a covering material on at least a portion of said frame.

3. The device of claim 2, wherein the covering material spans between adjacent first apposition members or between adjacent second apposition members.

4. The device of claim 1, wherein the middle portion defines at least one lumen extending between said first end and said second end.

5. The device of claim 1, wherein at least one said first apposition members is configured differently than one or more others of said first apposition members.

6. The device of claim 5, wherein at least one said first apposition members is longer than one or more others of said first apposition members.

7. The device of claim 1, wherein at least one of said first apposition members is longer than at least one of said second apposition members.

8. The device of claim 7, wherein all of said first apposition members are longer than all of said second apposition members.

9. The device of claim 1, wherein said plurality of first apposition members are in axial alignment with said plurality of second apposition members.

10. The device of claim 1, wherein said plurality of first apposition members are axially unaligned with said plurality of second apposition members.

11. The device of claim 10, wherein one or more of said plurality of first apposition members longitudinally overlap with one or more of said plurality of second apposition members.

12. A medical device comprising:

a frame comprising an elongate member defining:

a first apposition portion comprising one or more first flange members configured to contact a first tissue surface and to provide an apposition force against said first tissue surface;

a second apposition portion comprising one or more second flange members configured to contact a second tissue surface and to provide an apposition force against said second tissue surface; and

a central portion having a first end and a second end, said central portion defining a longitudinal axis, said central portion being disposed between and interconnecting said first apposition portion and said second apposition portion,

wherein at least one of said one or more first flange members and at least one of said second flange members comprises a radius portion and a descending portion that extends longitudinally toward said central portion,

wherein at least one of said radius portions of said one or more first flange members extends longitudinally beyond said first end, and

wherein at least one of said radius portions of said one or more second flange members extends longitudinally beyond said second end.

13. The medical device of claim 12, wherein at least one of said one or more first flange members or at least one of said one or more second flange members further comprises a horizontal portion extending from said descending portion.

14. The medical device of claim 12, wherein each of said one or more first flange members and each of said second flange members comprises a radius portion and a descending portion that extends longitudinally toward said central portion,

15. The medical device of claim 12, wherein said radius portions extend from said first end or said second end of said central portion.

16. The medical device of claim 12, wherein said descending portion is a linearly descending portion.

17. The medical device of claim 12, wherein the central portion defines a lumen extending between said first end and said second end.

18. The medical device of claim 12, wherein the central portion is configured to longitudinally extend and retract to maintain contact, over a range of tissue thicknesses, of the first and second apposition portions with the first and second tissue surfaces respectively.

19. A method of implanting an anastomosis device in a patient:
positioning a delivery sheath containing the anastomosis device at a target location within the patient, wherein the anastomosis device comprises:
an expandable frame having a first end, a second end, and a middle portion between said first end and said second end;
a first apposition portion comprising a plurality of first apposition members, each said first apposition member extending toward said middle portion, a first portion of each said first apposition member being oriented at a first angle in relation to a surface of said middle portion, a second portion of each said first apposition member being oriented at a second angle in relation to said surface of said middle portion, wherein said first angle is acute and is less than said second angle; and
a second apposition portion comprising a plurality of second apposition members, each said second apposition member extending toward said middle portion, a first portion of each said second apposition member being oriented at a third angle in relation to said surface of said middle portion, a second portion of each said second apposition member being oriented at a fourth angle in relation to said surface of said middle portion, wherein said third angle is acute and is less than said fourth angle; and
deploying the anastomosis device out from the delivery sheath such that at least one layer of tissue is between said first apposition portion and said second apposition portion.
20. The method of claim 19, wherein a tip portion of said plurality of first apposition members or said plurality of second apposition members is spaced apart from said tissue.
21. The method of claim 19, wherein two layers of tissue are between said first apposition portion and said second apposition portion.

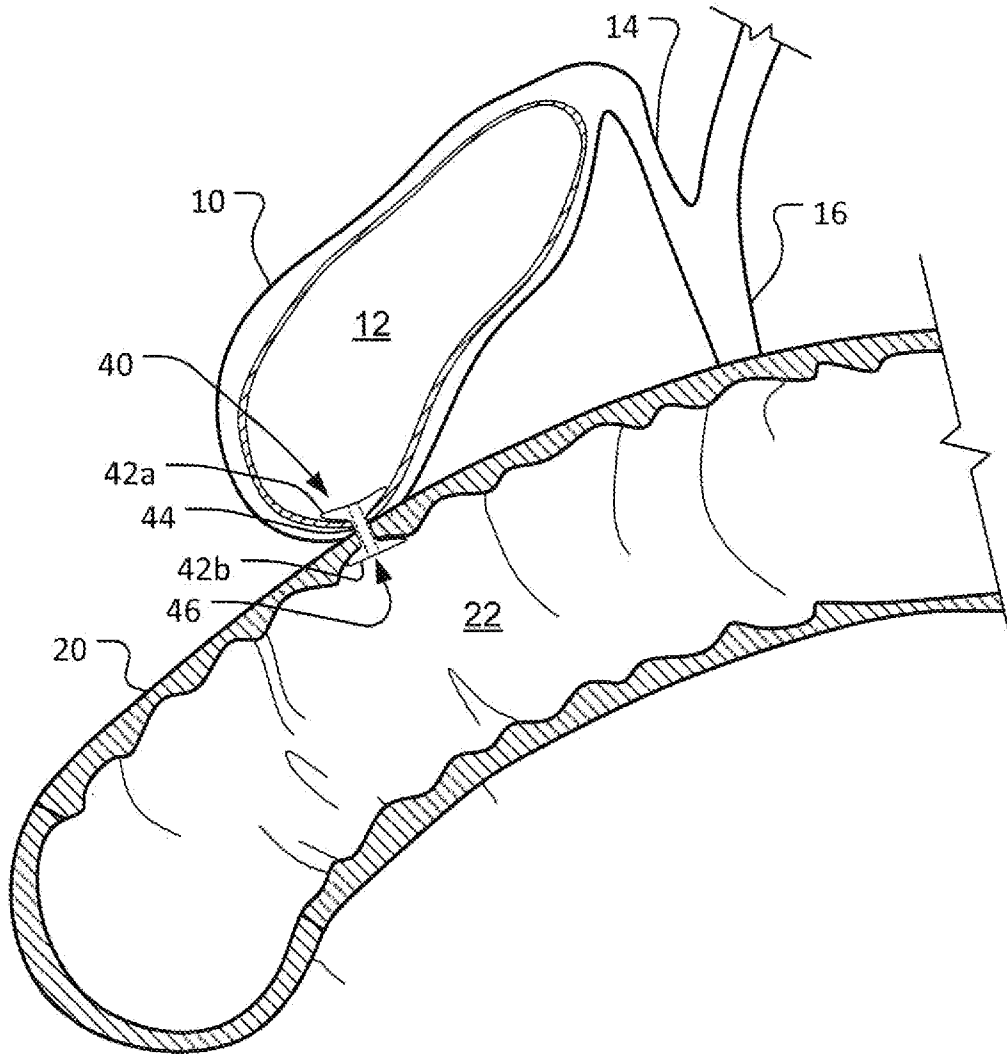

FIG. 1

2/7

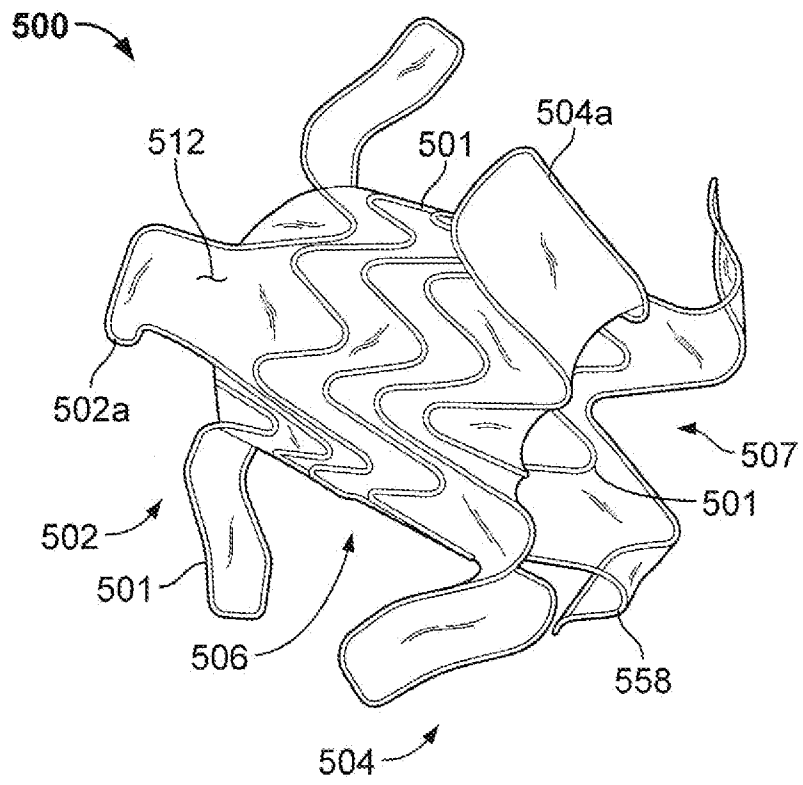

FIG. 2

3/7

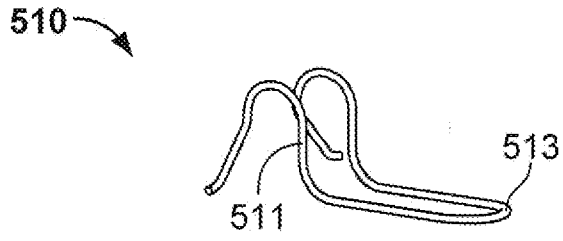

FIG. 3

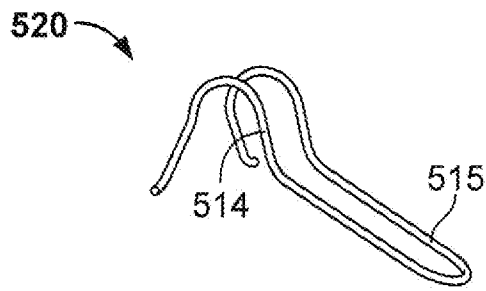

FIG. 4

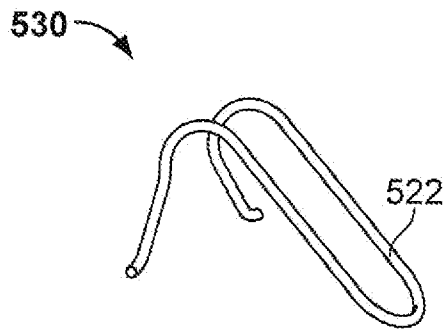

FIG. 5

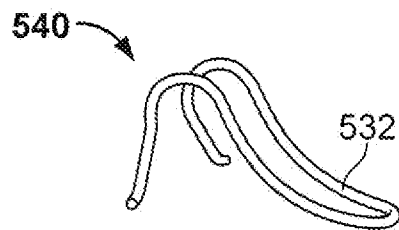

FIG. 6

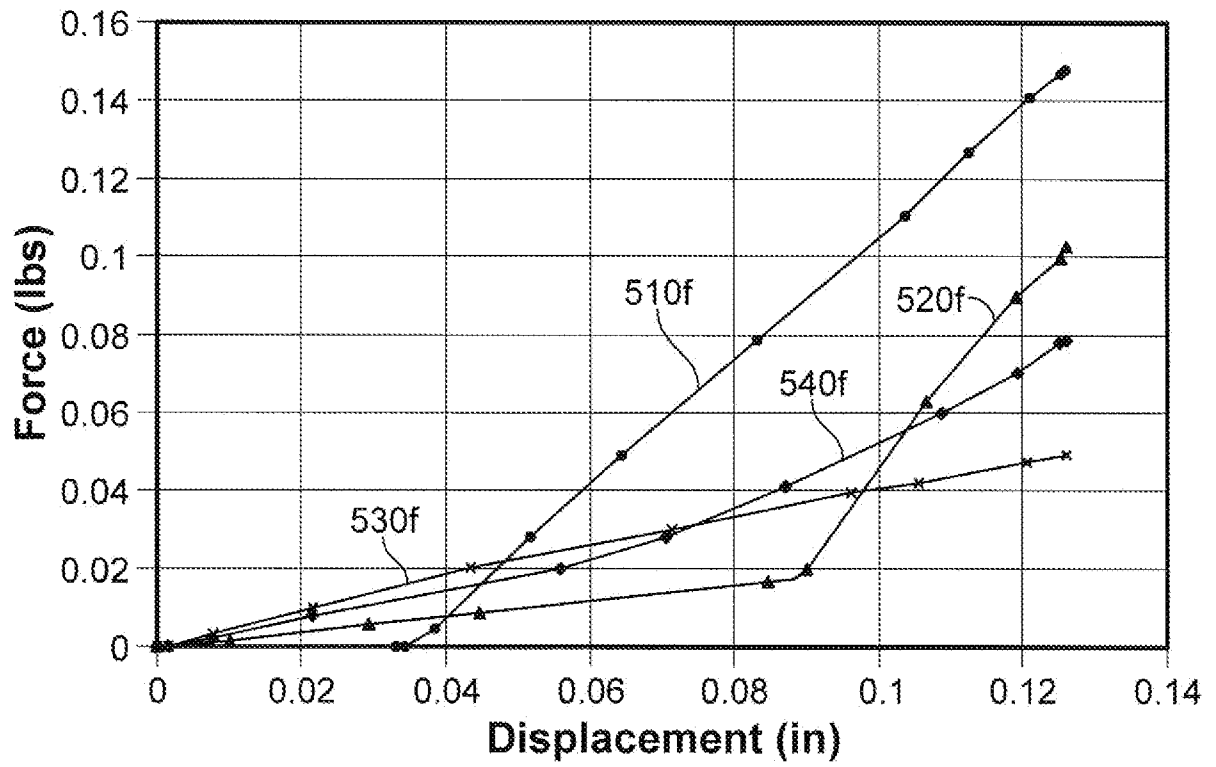

FIG. 7

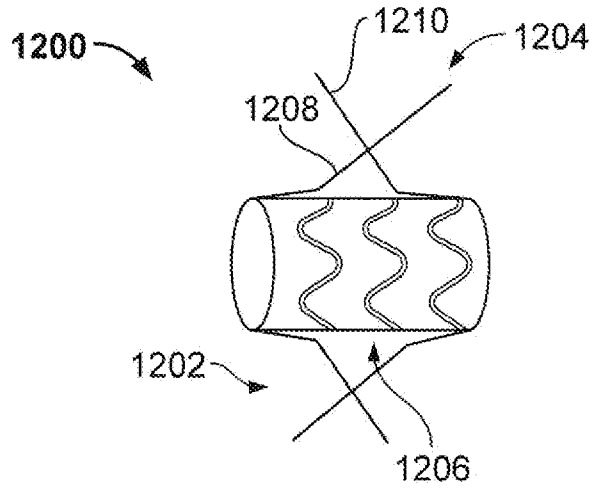

FIG. 8

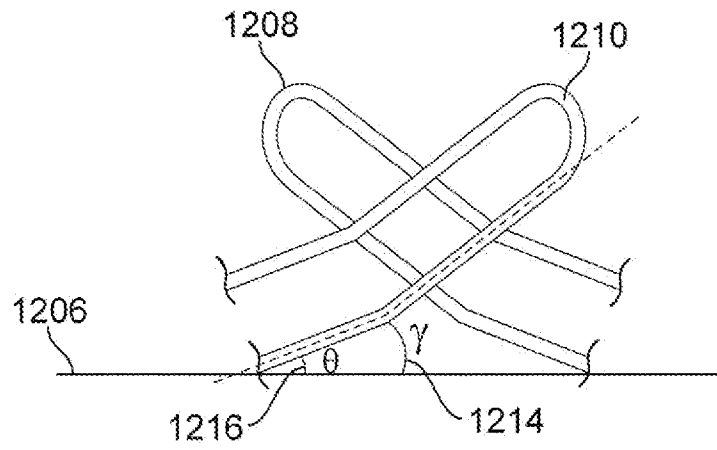

FIG. 9

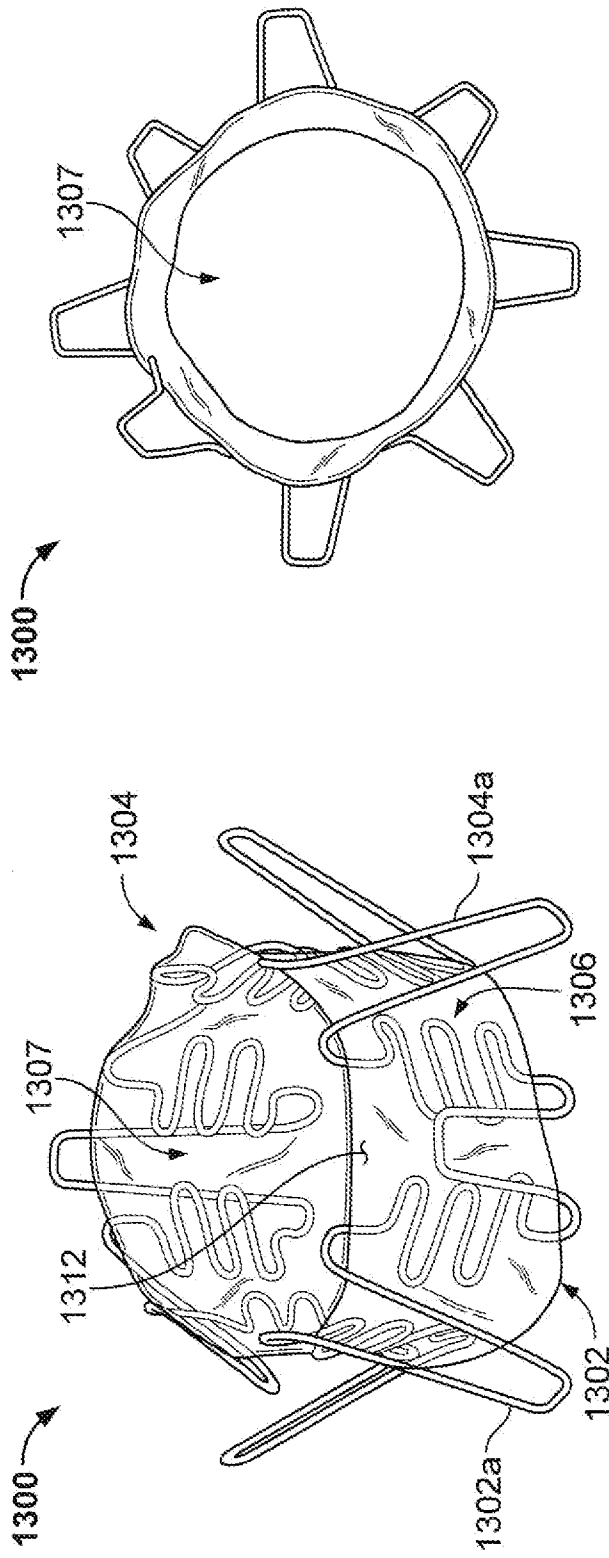

FIG. 11

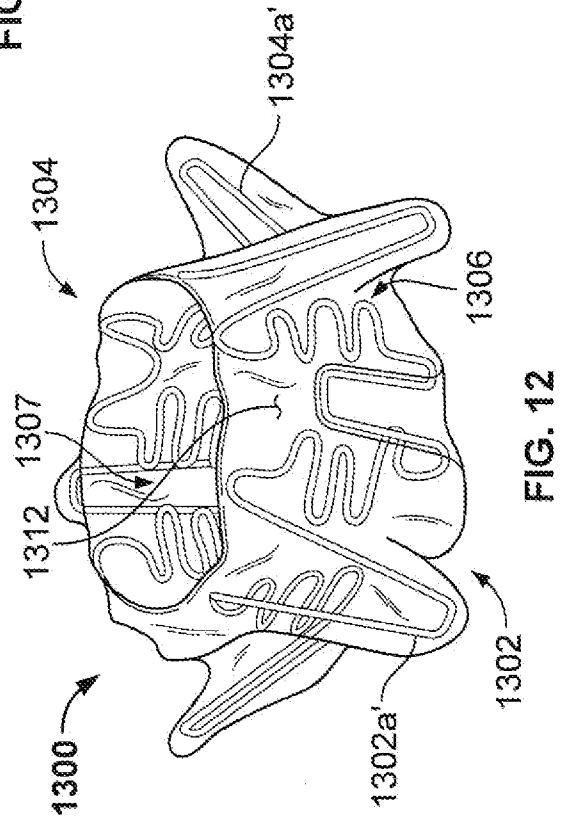

FIG. 12

FIG. 10

7/7

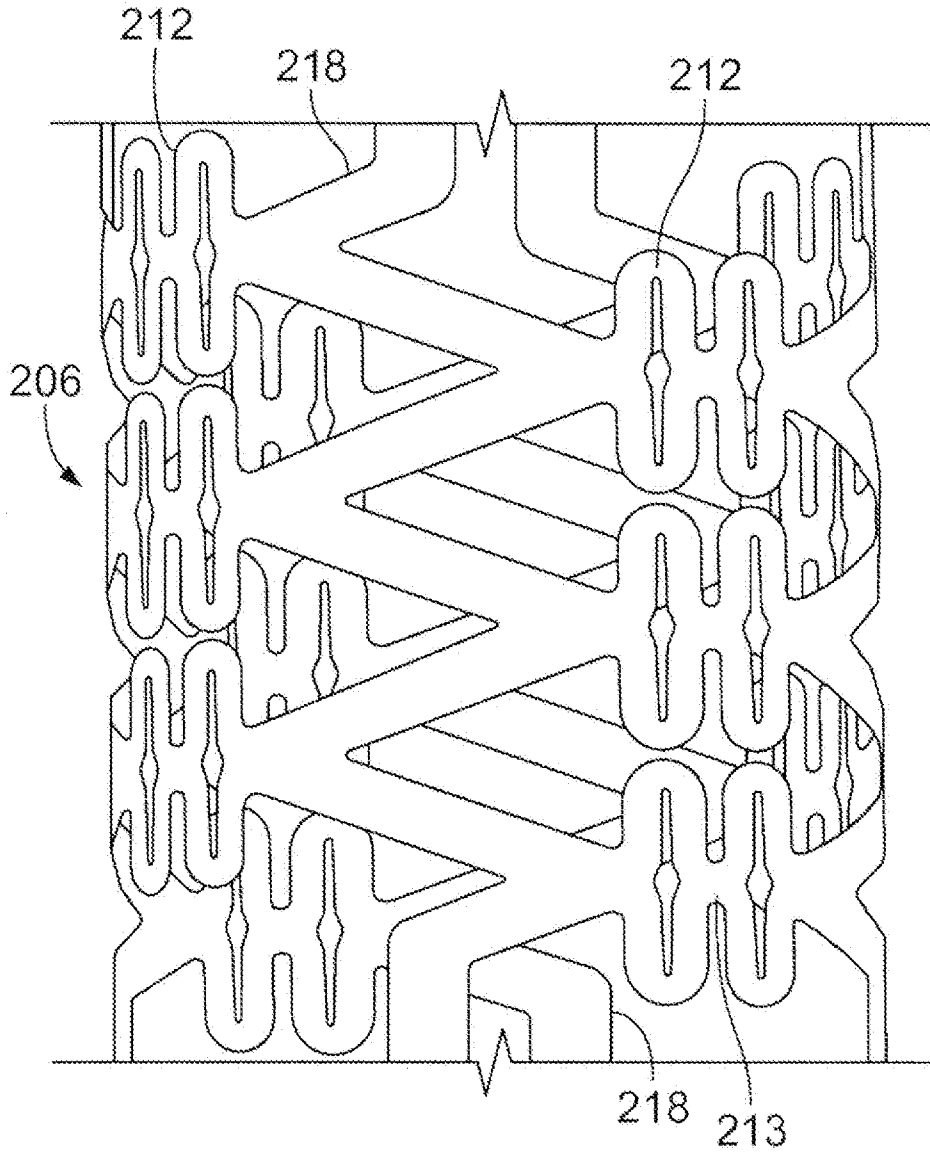

FIG. 13