

W. P. Martin,
Dressing Leather,

No 28,108.

Patented May 1, 1860.

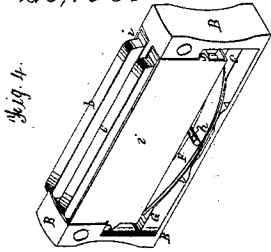

Fig. 4.

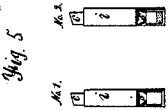

Fig. 5.

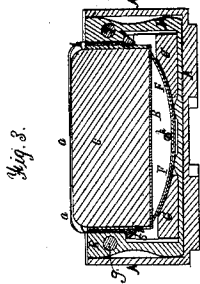

Fig. 3.

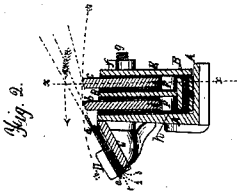

Fig. 2.

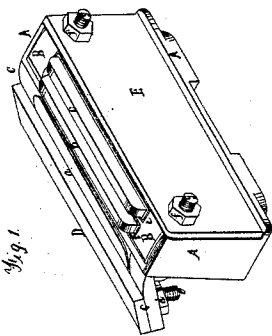

Fig. 1.

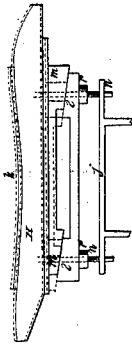

Fig. 11.

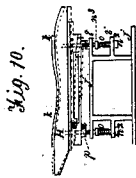

Fig. 10.

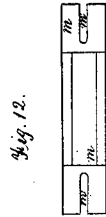

Fig. 12.

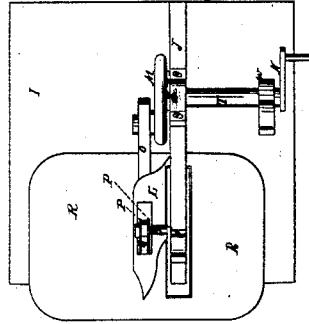

Fig. 9.

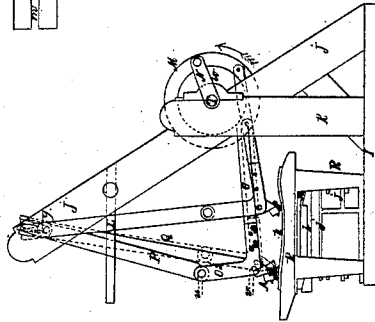

Fig. 8.

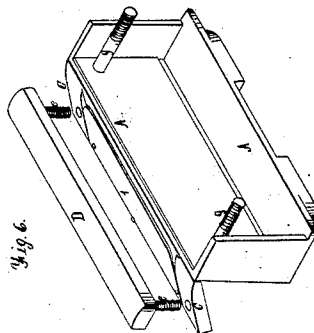
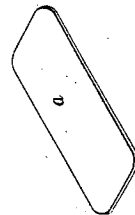

Fig. 6.

Fig. 7.



Witnesses
Thos. H. Southwick,
James. W. Mason.

Inventor
William P. Martin.

UNITED STATES PATENT OFFICE.

WILLIAM P. MARTIN, OF SALEM, MASSACHUSETTS.

MACHINE FOR FINISHING LEATHER.

Specification of Letters Patent No. 28,108, dated May 1, 1860.

To all whom it may concern:

Be it known that I, WM. P. MARTIN, of Salem, county of Essex, in the State of Massachusetts, have invented certain new and useful Improvements in Machinery for Finishing Leather; and I do hereby declare that the following is a full and exact description thereof, reference being had to the accompanying drawings and to the characters of reference marked thereon.

My invention relates to certain improvements in machinery for finishing leather and has for its object a novel construction of the "hand" which operates on the leather to finish its surface and for a further object a more perfect and desirable arrangement of mechanism for operating the "hand", and to these ends my present invention consists in constructing the hand with a yielding, or elastic plate (or tool) which is adjustable and reversible in the hand or tool stock, whereby said plate or tool stock is rendered capable of adjustment to keep its operating edge always in the same line and keep its elasticity always the same and capable of having four operating edges which may be used in succession before the re-sharpening of the tool is rendered necessary as will be hereinafter more fully described; and my invention further consists in the employment in combination with the "hand" of a tool of glass (or other suitable material) which is so constructed and arranged in the hand as to be capable of yielding either uniformly along its entire face or unevenly along its face as will be hereinafter fully described; and my invention further consists in the combination of two yielding tools with their faces formed each on a different angle from the other as will be hereinafter described; and my invention further consists in the combination of two yielding glass (or equivalent) tools with the spring plate tool, when the whole is so arranged as that the operating faces of the three tools shall have their "angles of bearing" diminished successively in the manner hereinafter to be described; and my invention further consists in arranging the glass tool in a case in such a manner that as the face of the tool is worn away it may be set out to be always in the same line relative to the other tools and to the hand,

or tool stock as will be hereinafter fully described; and my invention further consists in combining with the adjustable yielding table a device for further adjusting the said table to different height at pleasure without effecting the previous adjustment of its two ends relative to a horizontal line—as will be presently explained; and my invention further consists in a novel construction and combination of the lever and bars operating the hand as will be fully described hereinafter.

In the accompanying drawings forming part of this specification, Figure 1 illustrates, in perspective view, one of my improved "hands" for finishing leather. Fig. 2 represents a vertical cross section of the same. Fig. 3 represents a vertical longitudinal section of the same (at the line x, x , Fig. 1). Fig. 4 represents a perspective view of the tool holding frame. Fig. 5 represents in end elevations one of the tool cases. Fig. 6 represents a perspective view of the tool stock, or hand with all the removable devices detached. Fig. 7 represents a perspective view of the plate tool. Fig. 8 represents (on a decreased scale) a side elevation of the leather finishing machine. Fig. 9 represents a top view of the same and, Figs. 10, 11 and 12 are detail illustrative views to be hereinafter alluded to.

In the different views the same letters indicate the same parts of the apparatus.

A is the hand case which is made in the form of a rectangular box with two sides left open (see Fig. 6). It has cast with, or permanently secured to it, an obliquely arranged lip piece C, and is furnished with two projecting screw studs g, g . The lip C, has a depression during the greater part of its upper surface, in which depressions are secured by rivets three (or more) plates of spring steel, each of a different width as seen at 1, 2 and 3 (at Fig. 2), the top, or outside one of the said pieces coming flush with the top surface of the lip c , as seen at Fig. 6.

a is the spring plate tool, which is placed in the proper position, between the spring piece 1, and the retaining bar D, which latter is furnished with projecting screw studs e, e , that pass through holes in the lip C, and are furnished with nuts d, d , whereby the said tool plate a , is firmly secured in its

proper relative position on the lip of the case A.

B, is the tool frame in which are arranged the yielding tool cases *i, i*. This frame B, the form of which will be perfectly comprehended by reference to Figs. 2, 3 and 4, fits into the case A, the stud *g, g*, of the latter passing through holes in said frame B, and is secured therein by the cap plate E (see Figs. 1 and 2) which is held on by the nuts *f, f*.

The tools *b* and *c*, are made alike with the exception of the angle at which their faces are finished off. These tools are made of glass (but may be made of agate or other suitable substance) and are arranged in cases or stocks *i, i*. Each of these stocks is a duplicate of the other, hence the description of one will answer for both. Said case *i*, is a rectangular box of sheet metal of sufficient capacity to contain one of the glass tools "*b*," (with a suitable packing around it) allowing its operating face to project out, about a half inch, more or less (as illustrated) and said case *i*, is formed with a projecting lip or stop shoulder on either end as seen at *s s* (see Figs. 3, 4 and 5) below which the end of said case is left open showing the glass. The shoulders *s* hold the case *i* in the frame B, by coming against shoulders formed in said frame (as seen at Figs. 3 and 4) and the openings left in each end of said case *i*, are for the purpose of allowing the introduction of a wedge or backing to "set out" the glass as its face is worn away. This feature of my improvement will be fully understood by reference to Fig. 5, where "No. 1" illustrates an end elevation of one of the cases *i*, with the glass *c*, properly fitted in, and "No. 2" is a duplicate elevation with the glass supposed to have been worn and sharpened away about an eighth of an inch and as being, wedged, or set out, by a backing strip drawn in red lines, so as to have its operating face in the same position as previous to the wearing away of the glass.

G, are four india rubber blocks, two back of each of the cases *i*, each pair arranged as seen at Figs. 3 and 4.

F are semielliptical springs arranged in connection with the rubber springs G in manner illustrated, and retained by a pin *h*, passing through the frame B (see Figs. 2, 3 and 4).

In Figs. 8 and 9, (which are drawn on a much smaller scale than the preceding figures,) I represents the base of the apparatus, on which is erected an inclined or obliquely arranged standard, or frame piece J, properly braced, and a standard K. To the piece J is secured a horizontal plate L, near its upper end, on one side and on the same side of said piece J nearer its upper end is

fixed a projecting stud Y. On the standards J and K are arranged suitable bearing boxes *w, w*, for the shaft T on one end of which is arranged the driving fly wheel M, (on the other end is illustrated a crank and handle N, for turning said shaft which however in practice is driven by suitable motive power.)

R is the working table, which is made in the usual manner and with a portion of its top cut out to accommodate the yielding table on which the leather rests while being operated upon by the hand, (this yielding and adjustable table is represented in other figures and will be particularly described presently.)

On the stud Y are pivoted the upper ends of two (similar) pendulums P, P, which are jointed at their lower ends by pins *u*, to the upper ends of two bent arms or knees *o², o²*, which knees are securely fastened by bolts 4, 5, (see Fig. 8) to the connecting rod O, which coupled to the crank pin of the fly wheel M.

Q is a pendent arm which lies between the pairs of pendulums and knees, is slotted out at its upper end so as to play up and down around the pin *y*, and is pivoted by a pin *v*. To the knees *o²* at their bend or angle and on the lower end of the said arm Q is secured the "hand" A.

H is the yielding adjustable table on which the leather *k* is laid and which is supported on a frame work (see Figs. 8 and 10) *j* in such a manner as to be adjusted (up through the top of table R) to any desired height and to any desired inclination longitudinally to a horizontal line. The table H is steadied by screw rods *w, w*, (see Figs. 10 and 11,) the upper ends of which pass into vertical bearing slots in said table on which said table plays up and down. The rods *w*, move vertically in holes in the projecting portions *t, t'*, of frame *j* (see Fig. 10) being forced upward always by springs *o*, which press on the upper side of *t'* and the lower side of set nut *n³*. The set nuts *n³* are for the purpose of increasing or diminishing the intensity of the springs *o*, and the heads *n²* prevent the rods *n* from being forced out of the frame by the springs. Just above the part *t* of the frame *j* there is arranged on each of the rods *n*, a set nut *p*, on which rest two bars *l* and *m*, (these bars are best seen at Figs. 11 and 12 which show them in side and top view on an increased scale.) Said bars are retained laterally by the rods *n*, but are slotted out at *m'* so as to be capable of sliding longitudinally around said rods, and it will be seen that said bars are thus capable of sliding, one on the other, and that the adjacent and touching surfaces of said bars inclined (as shown at Figs. 10 and 11).

Previous to my invention the yielding plate tool has been permanently secured to the hand with a rubber spring strip under it; but in such an arrangement the elasticity of said plate changes as its edge is worn away closer to the spring strip. The position of its operating edge is also changed as it is worn away which has to be compensated for by setting up the table, and after it has been very partially worn away it has to be replaced by a new plate and while fit for use it has to be sharpened every time one edge is dulled. With my improvement the operating edge of the plate *a*, may be adjusted readily to a given line relative to the other parts of the hand whereby its elasticity remains always just the same and it swings while in operation in the same line of motion. It can also be turned up side down when one edge is worn to bring a new one to operate on the leather. It can further have the front side put back to bring a new and third edge into use.

Previous to my invention the glass or agate tool has been rigidly fixed in the hand so that the table had to yield to every unevenness of the surface of the leather being operated upon; but as the table yielded to the same extent in every point in a line drawn across it from side to side it followed that when an inequality existed near one edge of the table the table yielding under the pressure of the tool on this inequality would allow the tool to pass over the leather on the opposite edge without touching it; but with my improved method of arranging the glass tool in the hand (as already described) said tool yields at either end to accommodate itself to any inequality in a cross section of the surface of the table previous to the yielding of the table itself, the springs of which are made stronger than those of the hand.

By the employment of the two glasses *b*, and *c*, with their faces ground to a different angle, I accomplish in one operation a degree of perfection in the surface of the leather, which could before only be attained by successive operations.

In Fig. 2 the arrow illustrates the direction of motion of the hand while operating on the leather and the red line * * * represents the curve of the yielding table inverted. (In all the figures representing the hand and its parts said hand is drawn in an inverted position to that in which it would be while operating, but in the natural position for putting together and adjusting its parts previous to bolting it on to the arm A.) From this figure it will be seen that the prominent edge of each tool just touches the line of the table's curvature so that the tools will be all operating on the leather at the same time, and it will be further seen

by the blue lines that the angles formed by the faces of the tools *a*, *b*, *c*, with the surface of the bed or table diminished in each instance successively in the opposite direction to that of the hands motion. By this arrangement of the two yielding glasses *b* and *c* with the plate *a*, in the hand I have found in practice a better result to be produced than has been by any mechanism used previous to my invention.

In order to keep all the tools adjusted relatively to each other they must each have an adjustment. The glass tools I attain the adjustment in by arranging them in cases *i*, *i*, in which they may be "set out" as hereinbefore described. Previous to my invention the yielding table has been so arranged in the stationary table as to be capable of an adjustment up and down at each end and it has in some instances been differently arranged so as to be capable of adjustment bodily every point being raised and lowered simultaneously and to the same extent; but I have found in practice that it is very necessary that the table should be capable of an independent adjustment at each end, and in addition to this a means of readily elevating and depressing the table uniformly along its length while the machine is running. This end I have accomplished by employing in combination with the device for adjusting each end (as illustrated at Fig. 10) a device for raising the table after it has been adjusted by said first device. This method of raising and lowering the table uniformly while the machine is running is shown at Fig. 11, where the slide bars *l* and *m* are shown in changed positions in red lines and the effect in red lines, on the table H.

It is very necessary to the perfect working of the hand on the leather that the hand should be held at the same angle to the surface of the table, in every point of its path of motion while at the same time the hand (which runs on the table only in one direction) should be elevated as far above the table and occupy as much time as practical during its retrograde motion to allow the operators time to make such changes in the position of the table or leather as may appear necessary. To attain these ends the hand has been hung on a jointed arm to throw or flap up and down during the vibration of the arm, but in such construction exists a great practical objection in the throw of the lower limb of the swinging arm to which the hand is attached, for since the hand weighs from eight to ten pounds and the fly wheel runs pretty fast (in the machines running in my establishment, I am running the fly wheels at 120 revolutions per minute) it is obvious that the lower "limb" brought up with such a momentum as must

exist will soon become deranged and derange the other parts of the apparatus. In my improved machine these desired ends are perfectly attained by a simple and durable combination of devices.

Having described the several features of my invention as I have practiced them what I claim as new and desire to secure by Letters Patent is—

10 1. The employment of an adjustable and reversible plate *a*, in combination with a suitable spring and arranged on the hand substantially as and for the purposes specified.

15 2. I also claim the employment in the hand of a yielding tool *b*, so arranged in the hand as to be capable of yielding uniformly along its whole length or unevenly as hereinbefore described for the purposes set forth.

20 3. I also claim the combination of two or more yielding tools *b*, *c*, when their edges are each ground on a different angle as hereinbefore specified the whole arranged to operate as and for the purposes set forth.

4. I also claim the combination of the spring plate *a*, and yielding tools *b* and *c*, the whole arranged and operating as specified for the purposes set forth.

5. I also claim arranging each glass in a separate case *i*, in such manner that while the case always remains in the same relative position with the other parts of the hand the glass or tool may be set out as and for the purpose set forth.

6. I also claim in combination with the device for adjusting each end of the table separately, the bars *l*, and *m*, or their equivalents, for raising the whole table simultaneously, as and for the purposes set forth.

7. I also claim the combination of the slotted pendant *Q* pendulum bars *P*, *P*, bent arms *o*² *o*² and connecting rod *O*, with the fly wheel *M*, and fixed stud *Y*, the whole arranged to operate as and for the purposes specified.

WILLIAM P. MARTIN. [L. s.]

Witnesses:

THOS. H. FROTHINGHAM,
JAMES VAN HAGEN.