

No. 776,506.

PATENTED DEC. 6, 1904.

J. A. FAUGHT.
SHOVEL PLOW.

APPLICATION FILED MAY 16, 1904.

NO MODEL.

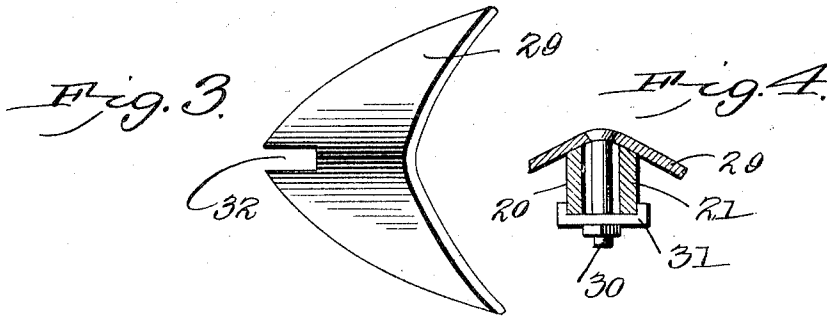
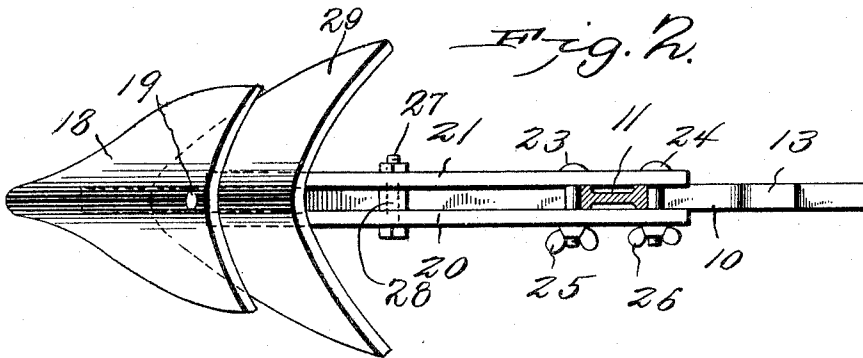
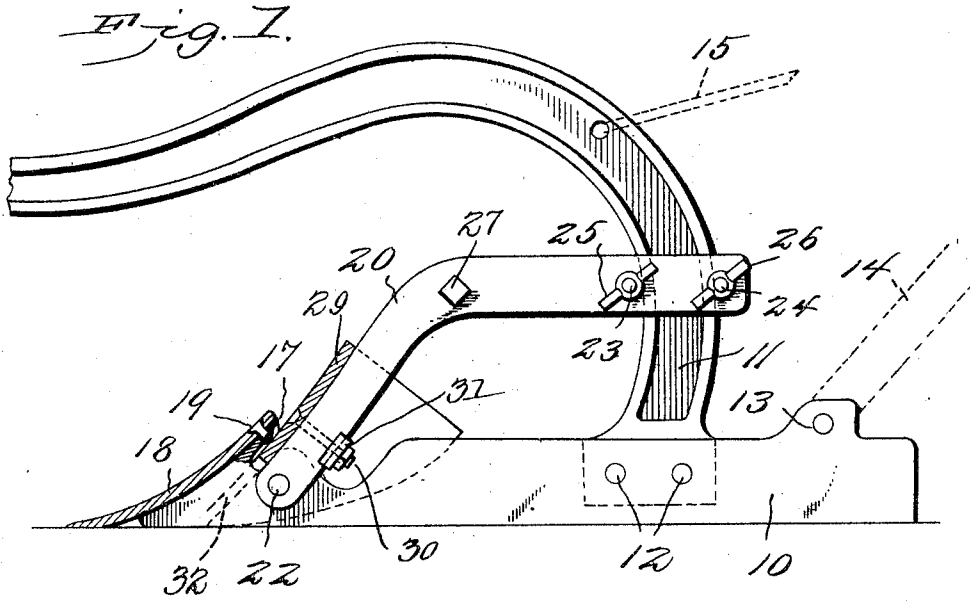

Witnesses
E. H. Stewart
C. N. Woodward

Jerry H. Faught, Inventor,
 by *C. A. Snow & Co.* Attorneys.

UNITED STATES PATENT OFFICE.

JERRY A. FAUGHT, OF EMET, INDIAN TERRITORY.

SHOVEL-PLOW.

SPECIFICATION forming part of Letters Patent No. 776,506, dated December 6, 1904.

Application filed May 16, 1904. Serial No. 208,246. (No model.)

To all whom it may concern:

Be it known that I, JERRY A. FAUGHT, a citizen of the United States, residing at Emet, in the Chickasaw Nation, Indian Territory, have invented a new and useful Shovel-Plow, of which the following is a specification.

This invention relates to plows or cultivators, more particularly to the class known as "shovel-plows," and has for its object to improve the construction and produce an implement of this character which may be inexpensively manufactured, is strong and durable, and which may be quickly adjusted to adapt it to varying qualities of soil and conditions of the crops.

With these and other objects in view, which will appear as the nature of the invention is better understood, the same consists in certain novel features of construction, as hereinafter fully described and claimed.

In the accompanying drawings, forming a part of this specification, and in which corresponding parts are denoted by like designating characters, is illustrated the preferred form of the embodiment of the invention capable of carrying the same into practical operation, it being understood that the invention is not necessarily limited thereto, as various changes in the shape, proportions, and general assemblage of the parts may be resorted to without departing from the principle of the invention or sacrificing any of its advantages, and the right is therefore reserved of making all the changes and modifications which fairly fall within the scope of the invention and the claims made therefor.

In the drawings thus employed, Figure 1 is a sectional side elevation, and Fig. 2 is a plan view, of the improved implement. Fig. 3 is a perspective view of the adjustable moldboard detached. Fig. 4 is a sectional detail of the means whereby the spreader is detachably coupled to the frame.

The improved device is designed for attachment to any of the various forms of steel plow-beams manufactured and to support any of the various forms of shovel-plow moldboards employed in connection with different kinds of crops, but for the purpose of illustration is shown applied to an ordinary cotton

or corn cultivator or plow having a "sweep" form of moldboard, to which form of plow it is more particularly adapted.

The improved device consists of a sole-bar or runner 10, to which the beam 11 of a plow is adapted to be connected, as by bolts or rivets 12. At its rear end the bar 10 is provided with an integral lug 13 to support the lower ends of the handles, (indicated by dotted lines, as at 14,) the handles being further supported by brace-rods (indicated by dotted lines, as at 15) from the beam and held spaced apart by the usual "rung" 16. At its forward end the bar 10 is provided with a rearwardly-inclined projection 17, to which the breaker-share or furrow-opener 18 is connected, as by rivets 19.

In the rear of the projection 17 two brace members 20 21 are disposed upon opposite sides of the bar 10 and extending upwardly and rearwardly upon opposite sides of the beam 11 and pivoted at 22 to the heel-bar by their lower ends and secured adjustably to the beam by clamp-bolts 23 24, the bolts provided with wing-nuts 25 26 to facilitate the adjustment. The members 20 21 are also connected between their end connections by a clamp-bolt 27 and spacer-block 28.

The member 29, which performs the functions of a moldboard or "spreader" of the earth turned up by the furrow-opener or "share" 18, rests upon the forward faces of the members 20 21, which are slightly convex to correspond to the convexity of the member 29 and is secured in place by a bolt 30, passing between the members 20 21 and engaging a clip 31 in the rear of the same, as shown more clearly in Fig. 4, which represents a sectional detail of this portion of the device. The member 29 is also provided with a cavity 32 for embracing the sole bar 10 at the bottom of the recess 17, which thus materially assists in supporting the member and preventing lateral movement thereto, while not interfering with the adjustment of the brace members 20 21 by the clamp-bolts 23 24. By this simple means it is obvious that the spreader member is adjustable independently of the furrow-opener member and may be elevated and depressed to any desired extent to increase or decrease the amount of the

sweep of the spreader members or to increase or decrease the extent of the furrow opened, and thus very effectually adapt the device to the growing crops. When operating between plants which are but slightly grown and where consequently a limited amount of earth only is required to be thrown around their roots, the members 20 21 will be elevated by adjusting the clamp-bolts 23 24 to cause the outer edges of the member 29 to move at a relatively high point above the earth, and thus effect only a limited amount of the earth thrown up by the furrow-opener member 18. Then as the plants increase in size and require an increased amount of earth around their roots to properly "hill" them the members 20 21 will be lowered to cause the outer edges of the member 29 to travel nearer the earth, and thus act upon a greater amount of the earth thrown up by the furrow-opener. By means of this simple device, therefore, it is obvious the spreader member may be caused to turn a narrow or wide furrow without disturbing or interfering with the action of the furrow-opener 18, and which is a very desirable and valuable advantage, especially in cultivating cotton, corn, and similar crops, as the device may be easily and quickly adapted to the crops as they increase in size by merely loosening the clamp-bolts 23 24 and adjusting the brace members, together with the spreader member carried by them.

Having thus fully described the invention, what is claimed is—

35 1. In a plow, a sole-bar, a plow-beam connected therewith, brace members connected pivotally with the sole-bar near the point thereof and having adjustable connection with

the plow-beam, and a spreader mounted upon the base members and having a notch straddling the sole-bar. 40

2. In a plow, a sole-bar having the plow-beam connected thereto, brace members movably connected by one end to said sole-bar and adjustably connected by the other ends to said beam, a furrow-opener connected to said sole-bar in advance of said brace members, and a spreader member attached to said brace members and extending laterally therefrom. 45

3. In a plow, a sole-bar having the plow-beam connected thereto, brace members spaced apart and movably connected at one end to the opposite sides of said sole-bar and adjustably connected at the other ends to opposite sides of said plow-beam, a furrow-opener connected to said sole-bar in advance of said brace members, a spreader member connected adjustably to said brace members and extending laterally therefrom. 50 55

4. In a plow, a sole-bar having the plow-beam connected thereto, brace members movably connected by one end to said sole-bar and adjustably connected by the other ends to said beam, a furrow-opener connected to said sole-bar in advance of said brace members, and a spreader member attached to said brace members and extending laterally therefrom and having a recess embracing said sole-bar in the rear of said furrow-opener. 60 65

In testimony that I claim the foregoing as my own I have hereto affixed my signature in the presence of two witnesses. 70

JERRY A. FAUGHT.

Witnesses:

JOSEPH B. SHAMON,
J. W. SHAMON.