



US00D509669S

(12) **United States Design Patent**
Krebs

(10) **Patent No.:** **US D509,669 S**

(45) **Date of Patent:** **** Sep. 20, 2005**

(54) **ACCESSORY RAIL**

(76) **Inventor:** **Marc K. Krebs**, 1000 Rand Rd., Unit 106, Wauconda, IL (US) 60084

(**) **Term:** **14 Years**

(21) **Appl. No.:** **29/200,233**

(22) **Filed:** **Feb. 24, 2004**

(51) **LOC (8) Cl.** **06-08**

(52) **U.S. Cl.** **D6/315**

(58) **Field of Search** D6/315, 320, 328,
D6/553, 567; D13/123; 211/13.1, 60.1,
71.1, 87.1, 94.1, 96, 85.3, 1

(56) **References Cited**

U.S. PATENT DOCUMENTS

- D209,521 S * 12/1967 Penland D6/320
- 4,828,121 A * 5/1989 Willcocks, Jr. 211/94.01
- D340,610 S * 10/1993 Hubbard D6/567
- D398,160 S * 9/1998 Umbarger D6/320

- D442,814 S * 5/2001 Sterling et al. D6/553
- D444,954 S * 7/2001 Umbarger D6/320
- D468,262 S * 1/2003 Lee D13/123

* cited by examiner

Primary Examiner—Stella Reid

Assistant Examiner—Shanda C. Hill

(74) *Attorney, Agent, or Firm*—Richard L. Mikesell

(57) **CLAIM**

The design for an accessory rail, as shown and described.

DESCRIPTION

FIG. 1 is a top left perspective view on an accessory rail showing my new design;
 FIG. 2 is a left side elevation view thereof, the right side being a mirror image thereto;
 FIG. 3 is a bottom plan view thereof;
 FIG. 4 is a front elevation view thereof; and,
 FIG. 5 is a rear elevation view thereof.

1 Claim, 2 Drawing Sheets

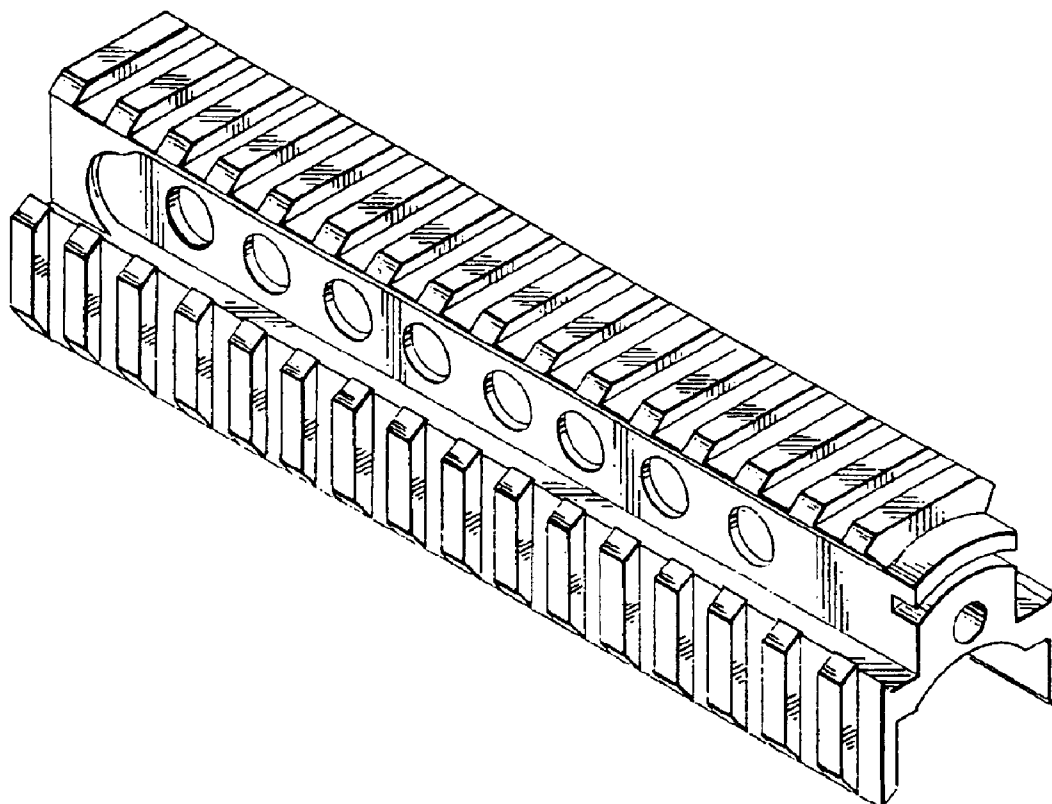

FIG. 1

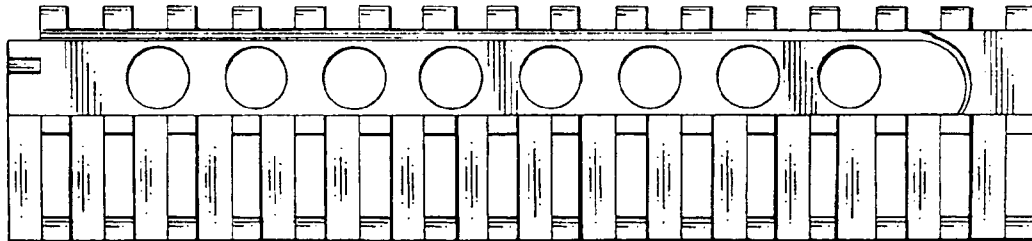
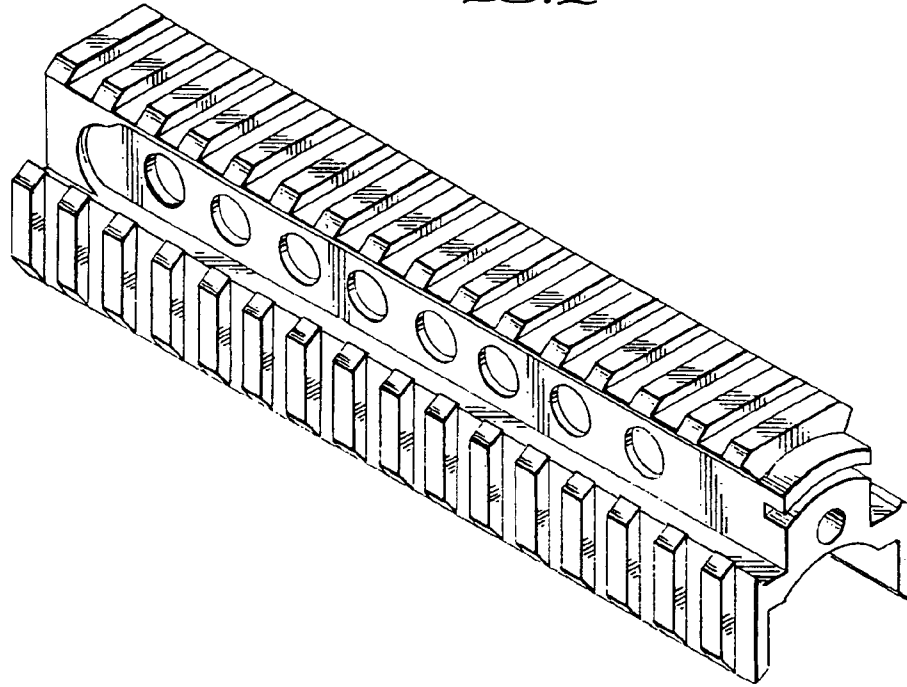

FIG. 2

FIG. 3

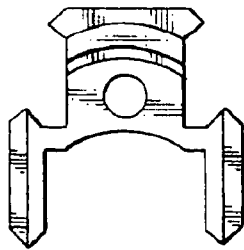
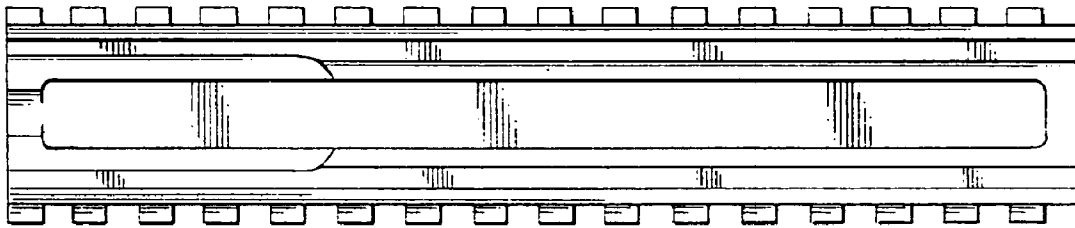

FIG. 4

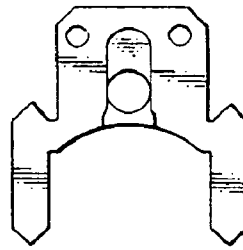

FIG. 5