



(19) **United States**

(12) **Patent Application Publication**  
**Schultz et al.**

(10) **Pub. No.: US 2004/0014077 A1**

(43) **Pub. Date: Jan. 22, 2004**

(54) **COMBINATORIAL SYNTHESIS OF NOVEL MATERIALS**

**Publication Classification**

(51) **Int. Cl.<sup>7</sup>** ..... **A61L 2/00; B05D 3/00; C12Q 1/68; G01N 33/53; C12M 1/34**

(76) Inventors: **Peter G. Schultz**, La Jolla, CA (US);  
**Xiao-Dong Xiang**, Danville, CA (US);  
**Isy Goldwasser**, Baldwin Park, CA (US);  
**Gabriel Briceno**, Baldwin Park, CA (US);  
**Xiao-Dong Sun**, Fremont, CA (US);  
**Kai-An Wang**, Cupertino, CA (US)

(52) **U.S. Cl.** ..... **435/6; 435/7.1; 435/287.1; 427/2.11; 436/518**

(57) **ABSTRACT**

Methods and apparatus for the preparation and use of a substrate having an array of diverse materials in predefined regions thereon. A substrate having an array of diverse materials thereon is generally prepared by delivering components of materials to predefined regions on a substrate, and simultaneously reacting the components to form at least two materials. Materials which can be prepared using the methods and apparatus of the present invention include, for example, covalent network solids, ionic solids and molecular solids. More particularly, materials which can be prepared using the methods and apparatus of the present invention include, for example, inorganic materials, intermetallic materials, metal alloys, ceramic materials, organic materials, organometallic materials, non-biological organic polymers, composite materials (e.g., inorganic composites, organic composites, or combinations thereof), etc. Once prepared, these materials can be screened for useful properties including, for example, electrical, thermal, mechanical, morphological, optical, magnetic, chemical, or other properties. Thus, the present invention provides methods for the parallel synthesis and analysis of novel materials having useful properties.

Correspondence Address:  
**Madeline I. Johnston, Esq.**  
**King & Spalding**  
**191 Peachtree Street**  
**Atlanta, GA 30303-1763 (US)**

(21) Appl. No.: **10/350,703**

(22) Filed: **Jan. 23, 2003**

**Related U.S. Application Data**

(60) Continuation of application No. 09/881,036, filed on Jun. 13, 2001, which is a division of application No. 09/127,195, filed on Jul. 31, 1998, now Pat. No. 6,346,290, which is a division of application No. 08/327,513, filed on Oct. 18, 1994, now Pat. No. 5,985,356.

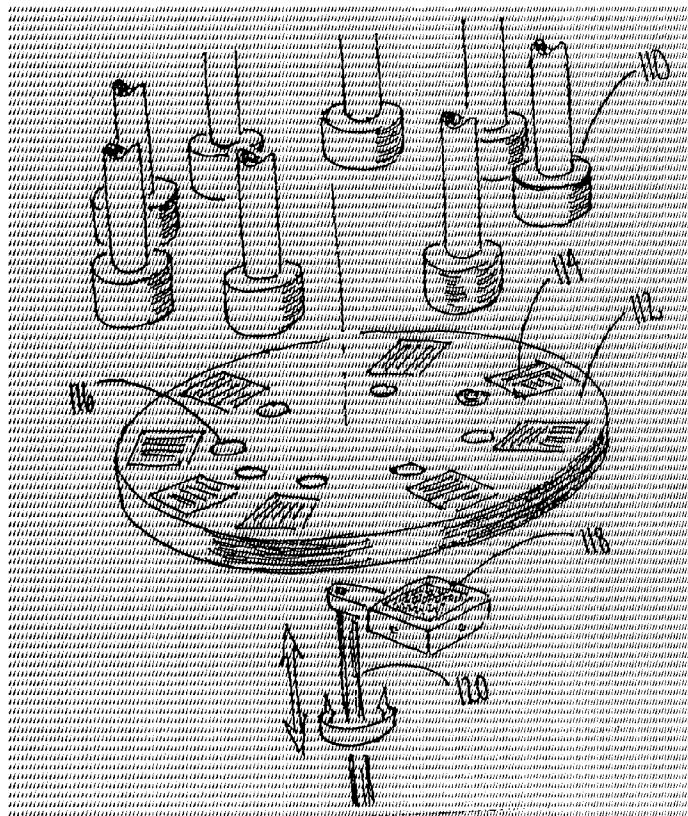

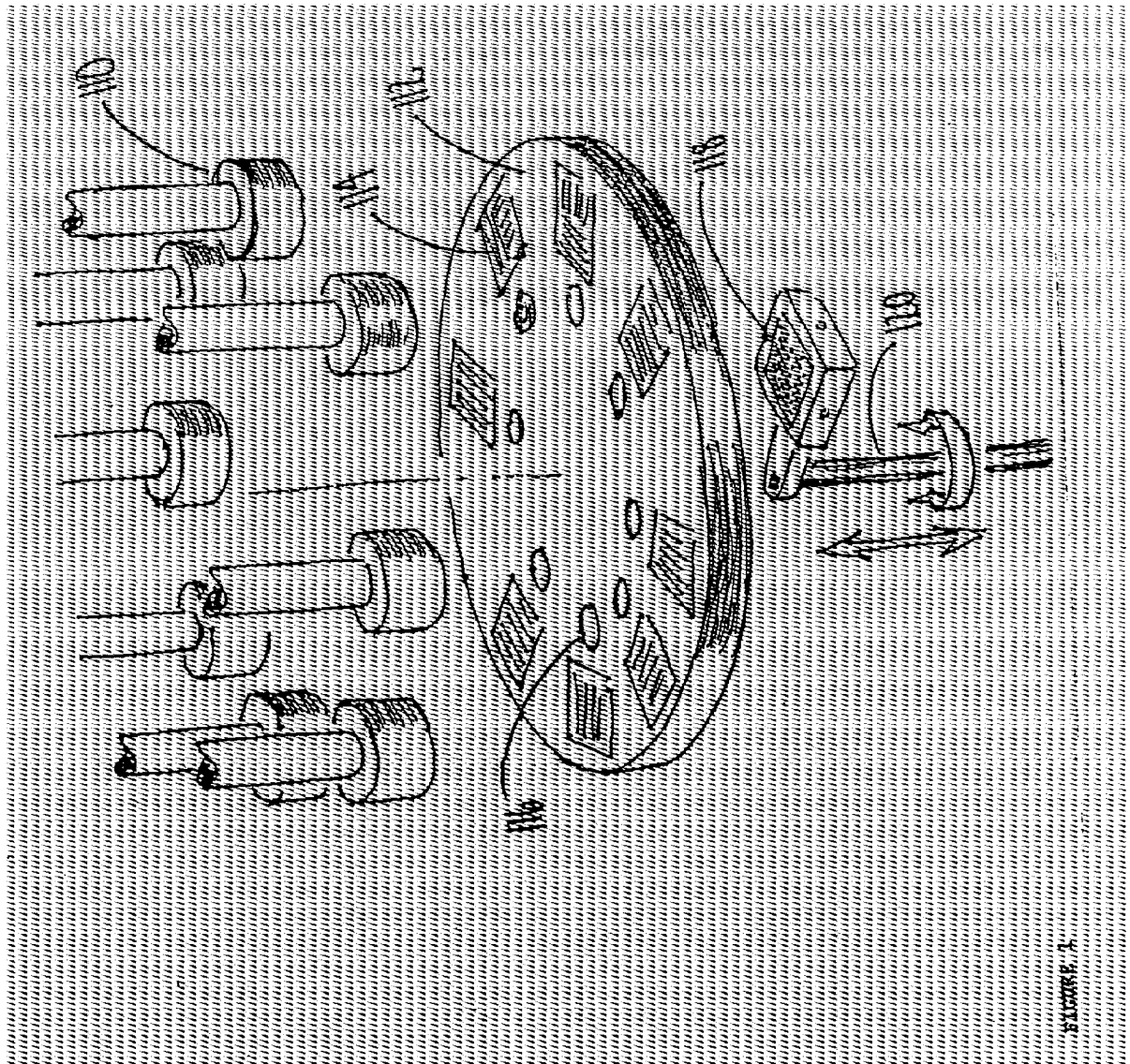

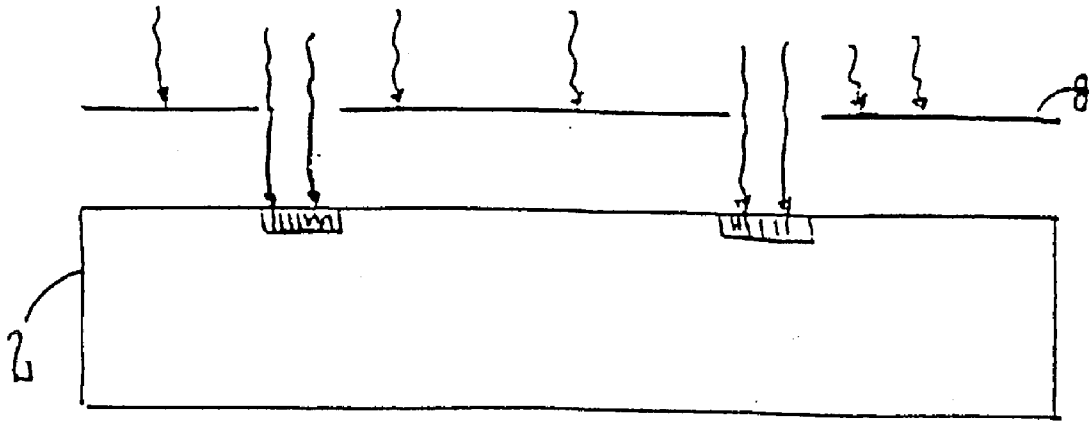

FIGURE 2

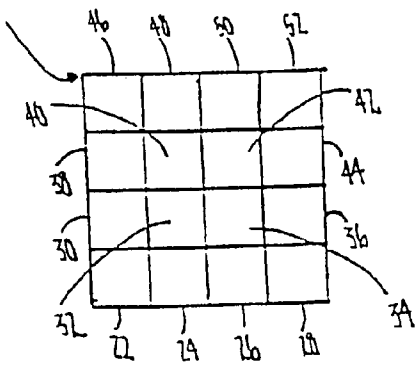

Fig. 3A

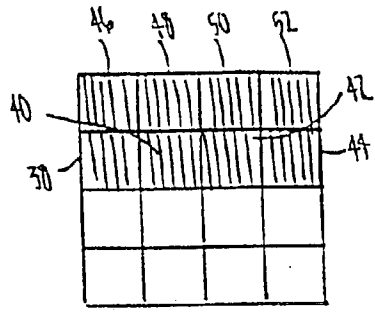

Fig. 3B

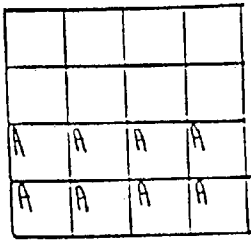

Fig. 3C

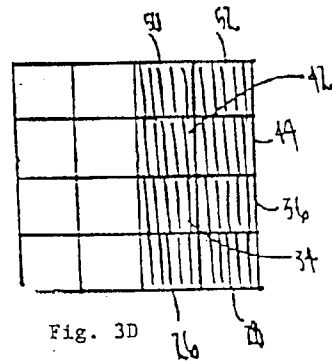

Fig. 3D

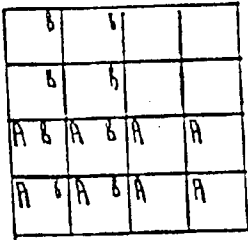

Fig. 3E

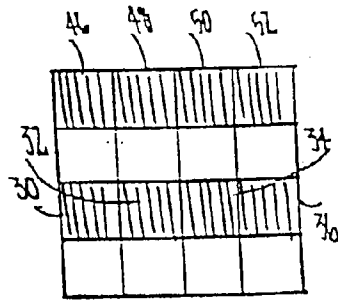

Fig. 3F

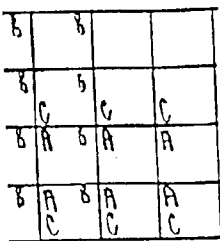

Fig. 3G

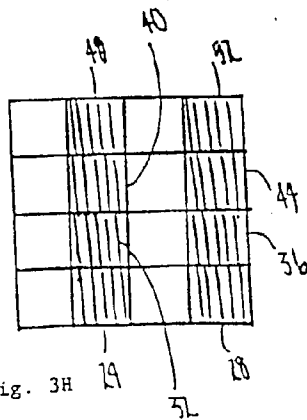

Fig. 3H

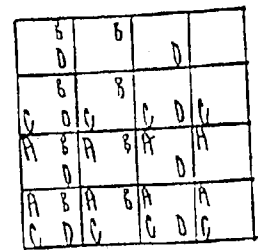

Fig. 3I

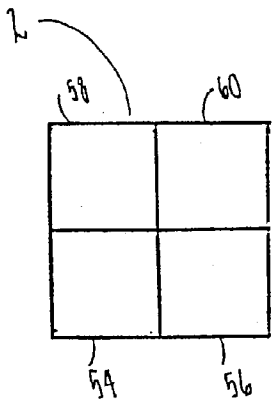

Fig. 4A

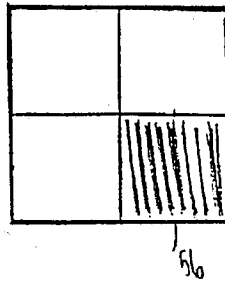

Fig. 4B

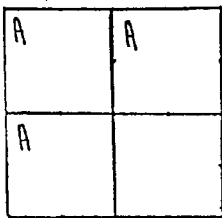

Fig. 4C

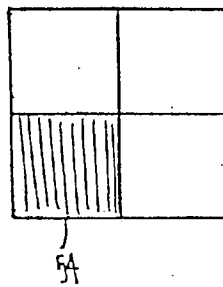

Fig. 4D

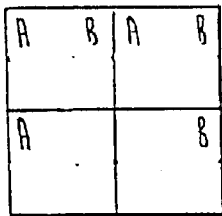

Fig. 4E

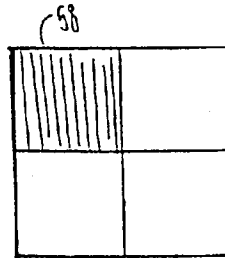

Fig. 4F

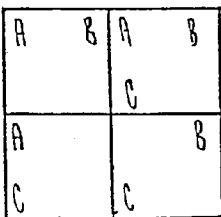

Fig. 4G

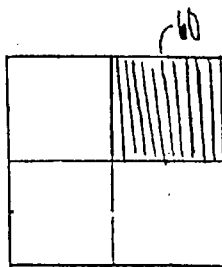

Fig. 4H

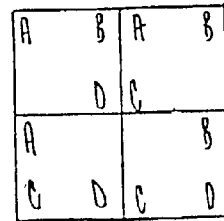
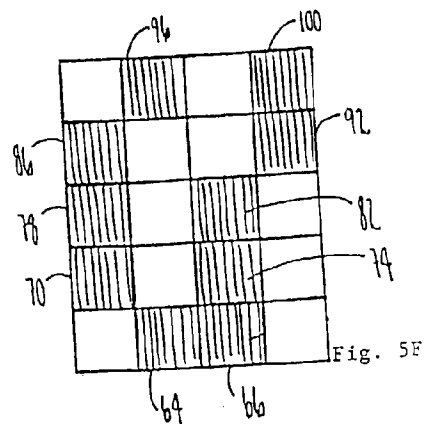
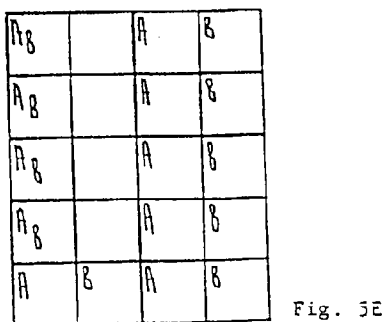
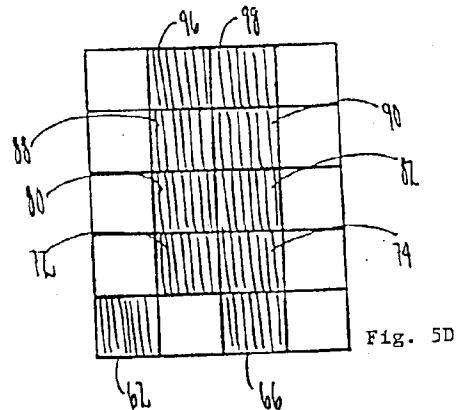
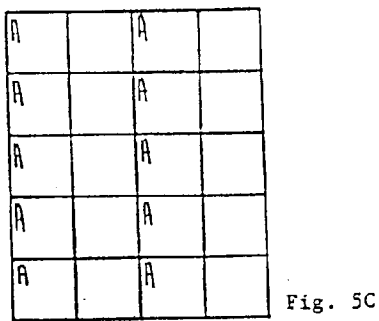
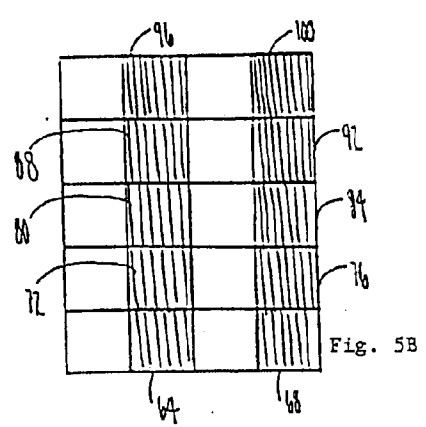
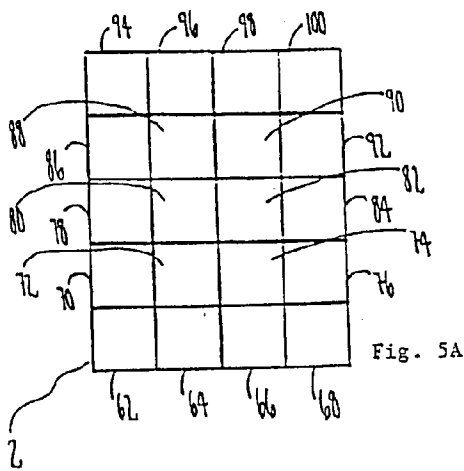

Fig. 4I



A B C		A C	B
A B	C	A C	B
A B	C	A	B C
A B	C	A	B C
A C	B	A	B C

Fig. 5G

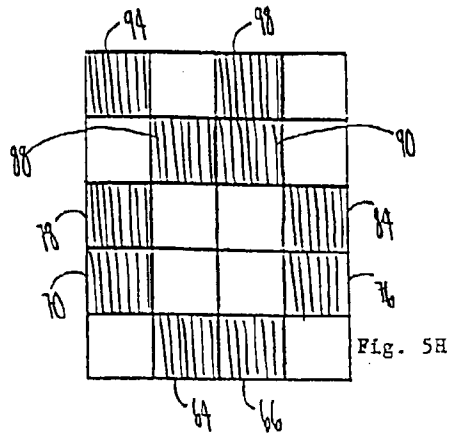

Fig. 5H

A B C	D	A C	B D
A B D	C	A C	B D
A B	C D	A D	B C
A B	C D	A D	B C
A C D	B	A	B C D

Fig. 5I

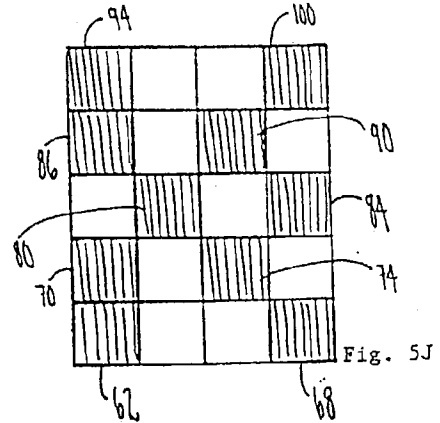

Fig. 5J

A B C	D E	A C E	B D
A B D	C E	A C	B D E
A B E	C D	A D E	B C
A B	C D E	A D	B C E
A C D	B E	A E	B C D

Fig. 5K

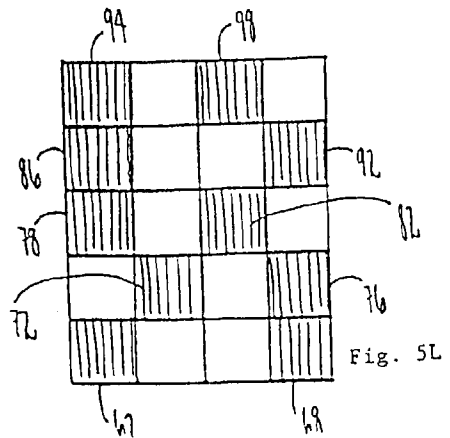

Fig. 5L

ABC	DEF	ACE	BCD
ABD	CEF	ACF	BDE
ABE	CDF	ADE	BCF
ABF	CDE	ADF	BCE
ACD	BEF	AEF	BCD

Fig. 5M



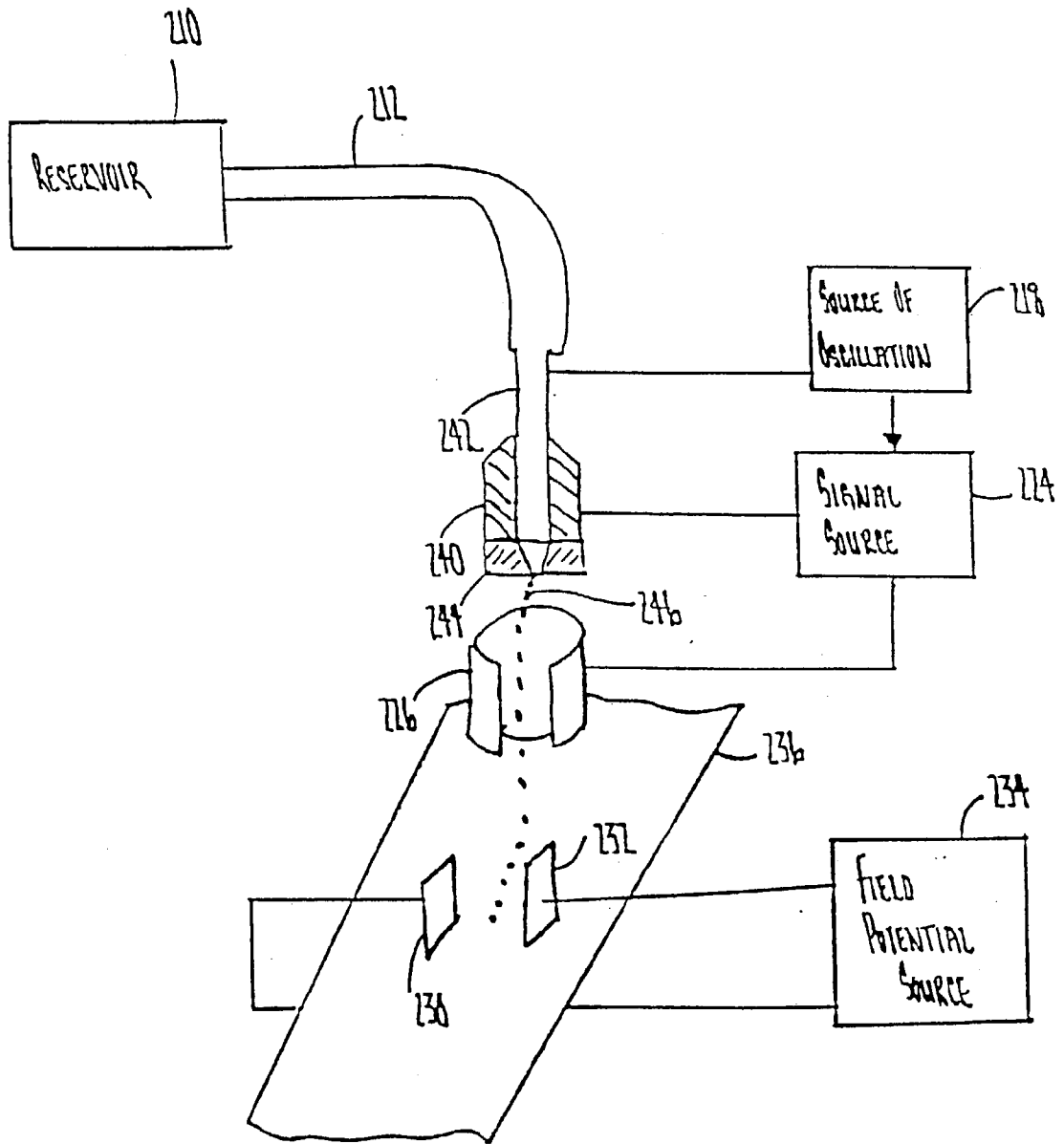

FIGURE 6

### RF Susceptiometer Design

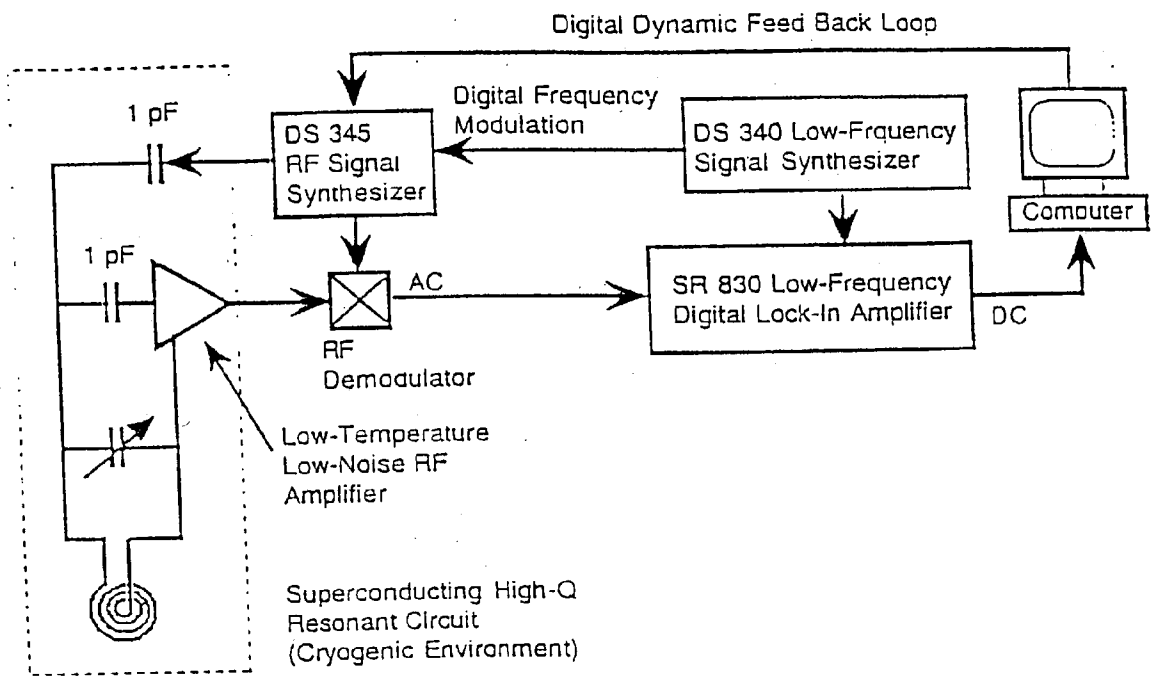
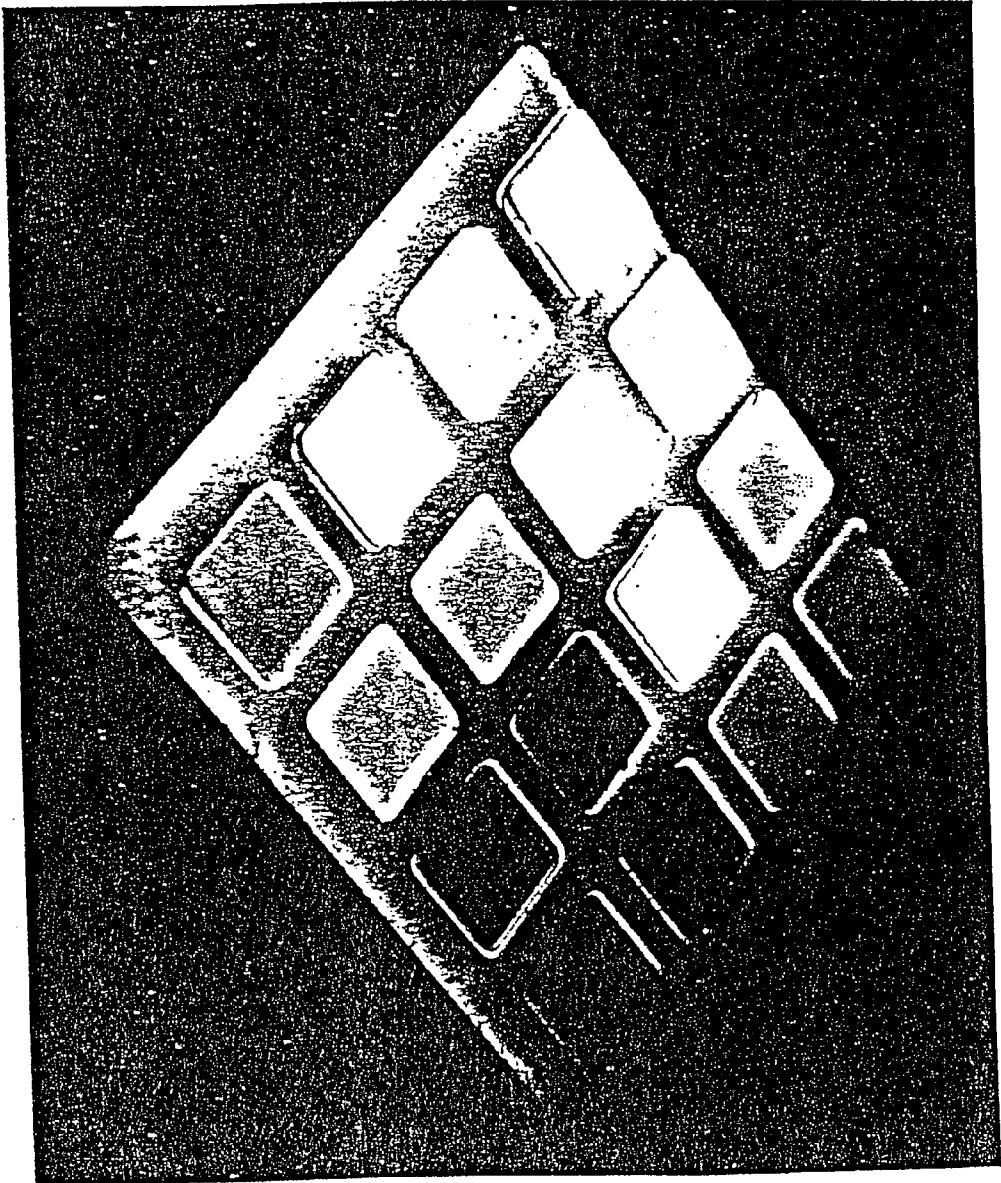

FIGURE 7

CuSr Ca	CuCa	CuPb SrCa	CuPb Ca
CuSr	Cu	CuPb Sr	CuPb
BiCu SrCa	BiCu Ca	BiPbCu SrCa	BiPb CuCa
BiCu Sr	BiCu	BiPb CuSr	BiPb Cu

FIGURE 8

Figure 9



Lib.(16) R vs T 10/7/94#2

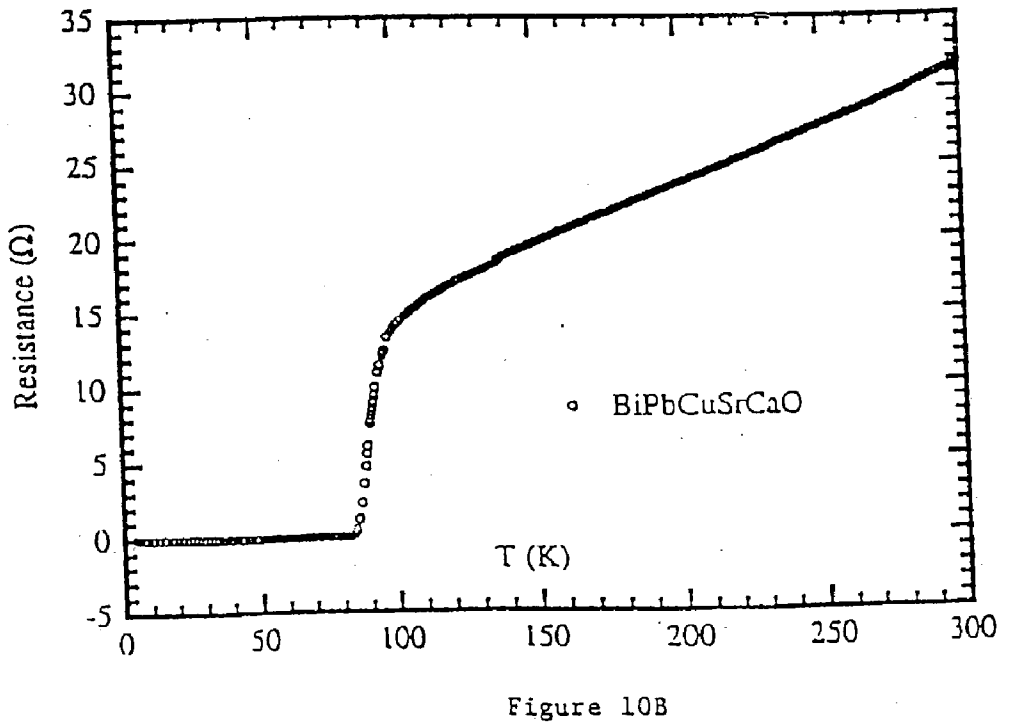
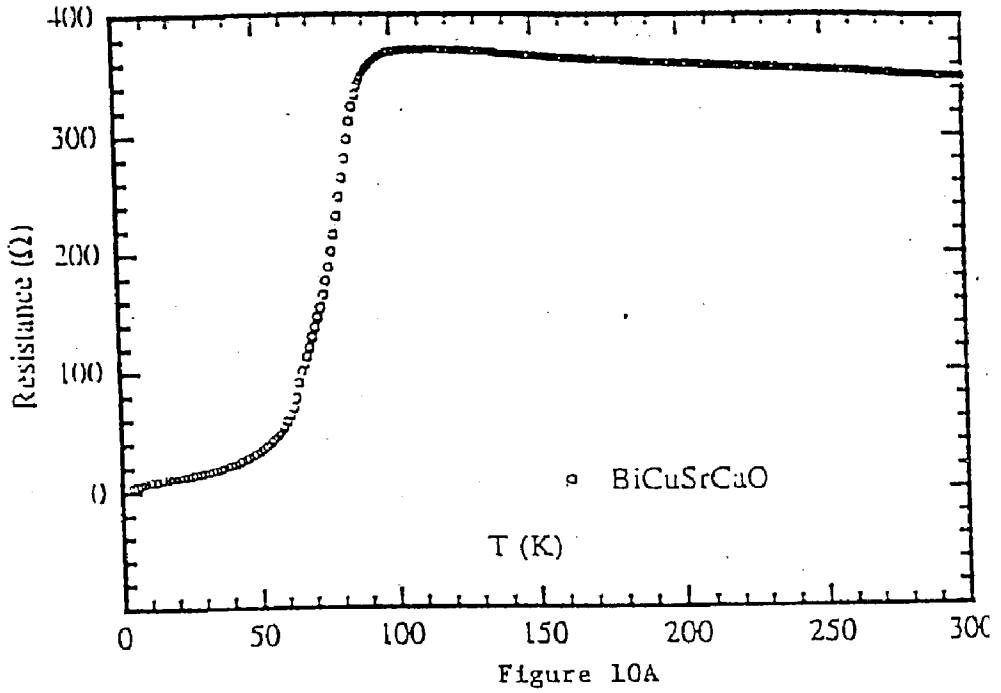

## COMBINATORIAL SYNTHESIS OF NOVEL MATERIALS

### STATEMENT OF GOVERNMENT INVENTION

[0001] This invention was made with Government support pursuant to Contract No. DE-AC03-76SF00098 awarded by the Department of Energy. The Government has certain rights in this invention.

### FIELD OF THE INVENTION

[0002] The present invention generally relates to methods and apparatus for the parallel deposition, synthesis and screening of an array of diverse materials at known locations on a single substrate surface. The invention may be applied, for example, to prepare covalent network solids, ionic solids and molecular solids. More specifically, the invention may be applied to prepare inorganic materials, intermetallic materials, metal alloys, ceramic materials, organic materials, organometallic materials, non-biological organic polymers, composite materials (e.g., inorganic composites, organic composites, or combinations thereof), etc. Once prepared, these materials can be screened in parallel for useful properties including, for example, electrical, thermal, mechanical, morphological, optical, magnetic, chemical, and other properties.

### BACKGROUND OF THE INVENTION

[0003] The discovery of new materials with novel chemical and physical properties often leads to the development of new and useful technologies. Over forty years ago, for example, the preparation of single crystal semiconductors transformed the electronics industry. Currently, there is a tremendous amount of activity being carried out in the areas of superconductivity, magnetic materials, phosphors, non-linear optics and high strength materials. Unfortunately, even though the chemistry of extended solids has been extensively explored, few general principles have emerged that allow one to predict with certainty composition, structure and reaction pathways for the synthesis of such solid state compounds. Moreover, it is difficult to predict a priori the physical properties a particular three dimensional structure will possess. Consider, for example, the synthesis of the  $\text{YBa}_2\text{Cu}_3\text{O}_{7-8}$  superconductor in 1987. Soon after the discovery of the  $\text{La}_{2-x}\text{Sr}_x\text{CuO}_4$  superconductor, which adopts the  $\text{K}_2\text{NiF}_4$  structure (Bednorz, I. G. and K. A. Muller, *Z. Phys. B* 64:189 (1986), it was observed that the application of pressure increased the transition temperature (Chu, et al., *Phys. Rev. Lett.* 58:405 (1987)). As such, Chu, et al. attempted to synthesize a Y—Ba—Cu—O compound of the same stoichiometry in the hope that substitution of the smaller element, i.e., yttrium, for lanthanum would have the same effect. Although they found superconductivity above 93K, no phase with  $\text{K}_2\text{NiF}_4$  structure was observed (Wu, et al., *Phys. Rev. Lett.* 58:908 (1987)). Even for the relatively simple intermetallic compounds, such as the binary compounds of nickel and zirconium ( $\text{Ni}_5\text{Zr}$ ,  $\text{Ni}_7\text{Zr}_2$ ,  $\text{Ni}_3\text{Zr}$ ,  $\text{Ni}_2\text{Zr}_8$ ,  $\text{Ni}_{10}\text{Zr}_7$ ,  $\text{Ni}_{11}\text{Zr}_9$ ,  $\text{NiZr}$  and  $\text{NiZr}_2$ ), it is not yet understood why only certain stoichiometries occur.

[0004] Clearly, the preparation of new materials with novel chemical and physical properties is at best happenstance with our current level of understanding. Consequently, the discovery of new materials depends largely on

the ability to synthesize and analyze new compounds. Given approximately 100 elements in the periodic table which can be used to make compositions consisting of three, four, five, six or more elements, the universe of possible new compounds remains largely unexplored. As such, there exists a need in the art for a more efficient, economical and systematic approach for the synthesis of novel materials and for the screening of such materials for useful properties.

[0005] One of the processes whereby nature produces molecules having novel functions involves the generation of large collections (libraries) of molecules and the systematic screening of those libraries for molecules having a desired property. An example of such a process is the humoral immune system which in a matter of weeks sorts through some  $10^{12}$  antibody molecules to find one which specifically binds a foreign pathogen (Nisonoff, et al., *The Antibody Molecule* (Academic Press, New York, 1975)). This notion of generating and screening large libraries of molecules has recently been applied to the drug discovery process. The discovery of new drugs can be likened to the process of finding a key which fits a lock of unknown structure. One solution to the problem is to simply produce and test a large number of different keys in the hope that one will fit the lock.

[0006] Using this logic, methods have been developed for the synthesis and screening of large libraries (up to  $10^{14}$  molecules) of peptides, oligonucleotides and other small molecules. Geysen, et al., for example, have developed a method wherein peptide syntheses are carried out in parallel on several rods or pins (see, *J. Immun. Meth.* 102:259-274 (1987), incorporated herein by reference for all purposes). Generally, the Geysen, et al. method involves functionalizing the termini of polymeric rods and sequentially immersing the termini in solutions of individual amino acids. In addition to the Geysen, et al. method, techniques have recently been introduced for synthesizing large arrays of different peptides and other polymers on solid surfaces. Pirrung, et al., have developed a technique for generating arrays of peptides and other molecules using, for example, light-directed, spatially-addressable synthesis techniques (see, U.S. Pat. No. 5,143,854 and PCT Publication No. WO 90/15070, incorporated herein by reference for all purposes). In addition, Fodor, et al. have developed, among other things, a method of gathering fluorescence intensity data, various photosensitive protecting groups, masking techniques, and automated techniques for performing light-directed, spatially-addressable synthesis techniques (see, Fodor, et al., PCT Publication No. WO 92/10092, the teachings of which are incorporated herein by reference for all purposes).

[0007] Using these various methods, arrays containing thousands or millions of different elements can be formed (see, U.S. Patent Application No. 805,727, filed Dec. 6, 1991, the teachings of which are incorporated herein by reference for all purposes). As a result of their relationship to semiconductor fabrication techniques, these methods have come to be referred to as "Very Large Scale Immobilized Polymer Synthesis," or "VLSIPS™" technology. Such techniques have met with substantial success in, for example, screening various ligands such as peptides and oligonucleotides to determine their relative binding affinity to a receptor such as an antibody.

[0008] The solid phase synthesis techniques currently being used to prepare such libraries involve the stepwise,

i.e., sequential, coupling of building blocks to form the compounds of interest. In the Pirrung, et al. method, for example, polypeptide arrays are synthesized on a substrate by attaching photoremovable groups to the surface of the substrate, exposing selected regions of the substrate to light to activate those regions, attaching an amino acid monomer with a photoremovable group to the activated region, and repeating the steps of activation and attachment until polypeptides of the desired length and sequences are synthesized. These solid phase synthesis techniques, which involve the sequential coupling of building blocks (e.g., amino acids) to form the compounds of interest, cannot readily be used to prepare many inorganic and organic compounds.

[0009] From the above, it is seen that a method and apparatus for synthesizing and screening libraries of materials, such as inorganic materials, at known locations on a substrate is desired.

#### SUMMARY OF THE INVENTION

[0010] The present invention provides methods and apparatus for the preparation and use of a substrate having an array of diverse materials in predefined regions thereon. A substrate having an array of diverse materials thereon is prepared by delivering components of materials to Predefined regions on the substrate, and simultaneously reacting the components to form at least two materials. Materials which can be prepared using the methods and apparatus of the present invention include, for example, covalent network solids, ionic solids and molecular solids. More particularly, materials which can be prepared include inorganic materials, intermetallic materials, metal alloys, ceramic materials, organic materials, organometallic materials, non-biological organic polymers, composite materials (e.g., inorganic composites, organic composites, or combinations thereof), etc. Once prepared, these materials can be screened in parallel for useful properties including, for example, electrical, thermal, mechanical, morphological, optical, magnetic, chemical and other properties. As such, the present invention provides methods and apparatus for the parallel synthesis and analysis of novel materials having new and useful properties. Any material found to possess a useful property can be subsequently prepared on a large-scale.

[0011] In one embodiment of the present invention, a first component of a first material is delivered to a first region on a substrate, and a first component of a second material is delivered to a second region on the same substrate. Thereafter, a second component of the first material is delivered to the first region on the substrate, and a second component of the second material is delivered to the second region on the substrate. The process is optionally repeated, with additional components, to form a vast array of components at predefined, i.e., known, locations on the substrate. Thereafter, the components are simultaneously reacted to form at least two materials. The components can be sequentially or simultaneously delivered to predefined regions on the substrate in any stoichiometry, including a gradient of stoichiometries, using any of a number of different delivery techniques.

[0012] In another embodiment of the present invention, a method is provided for forming at least two different arrays of materials by delivering substantially the same reaction components at substantially identical concentrations to reac-

tion regions on both first and second substrates and, thereafter, subjecting the components on the first substrate to a first set of reaction conditions and the components on the second substrate to a second set of reaction conditions. Using this method, the effects of the various reaction parameters can be studied on many materials simultaneously and, in turn, such reaction parameters can be optimized. Reaction parameters which can be varied include, for example, reactant amounts, reactant solvents, reaction temperatures, reaction times, the pressures at which the reactions are carried out, the atmospheres in which the reactions are conducted, the rates at which the reactions are quenched, the order in which the reactants are deposited, etc.

[0013] In the delivery systems of the present invention, a small, precisely metered amount of each reactant component is delivered into each reaction region. This may be accomplished using a variety of delivery techniques, either alone or in combination with a variety of masking techniques. For example, thin-film deposition in combination with physical masking or photolithographic techniques can be used to deliver various reactants to selected regions on the substrate. Reactants can be delivered as amorphous films, epitaxial films, or lattice and superlattice structures. Moreover, using such techniques, reactants can be delivered to each site in a uniform distribution, or in a gradient of stoichiometries. Alternatively, the various reactant components can be deposited into the reaction regions of interest from a dispenser in the form of droplets or powder. Suitable dispensers include, for example, micropipettes, mechanisms adapted from ink-jet printing technology, or electrophoretic pumps.

[0014] Once the components of interest have been delivered to predefined regions on the substrate, they can be reacted using a number of different synthetic routes to form an array of materials. The components can be reacted using, for example, solution based synthesis techniques, photochemical techniques, polymerization techniques, template directed synthesis techniques, epitaxial growth techniques, by the sol-gel process, by thermal, infrared or microwave heating, by calcination, sintering or annealing, by hydrothermal methods, by flux methods, by crystallization through vaporization of solvent, etc. Thereafter, the array can be screened for materials having useful properties.

[0015] In another embodiment of the present invention, an array of inorganic materials on a single substrate at predefined regions thereon is provided. Such an array can consist of more than  $10$ ,  $10^2$ ,  $10^3$ ,  $10^4$ ,  $10^5$  or  $10^6$  different inorganic compounds. It should be noted that when gradient libraries are prepared in each of the predefined reaction regions, a virtually infinite number of inorganic materials can be prepared on a single substrate. In some embodiments, the density of regions per unit area will be greater than  $0.04$  regions/cm<sup>2</sup>, more preferably greater than  $0.1$  regions/cm<sup>2</sup>, even more preferably greater than  $1$  region/cm<sup>2</sup>, even more preferably greater than  $10$  regions/cm<sup>2</sup>, and still more preferably greater than  $100$  regions/cm<sup>2</sup>. In most preferred embodiments, the density of regions per unit area will be greater than  $1,000$  regions/cm<sup>2</sup>, more preferably  $10,000$  regions/cm<sup>2</sup>, even more preferably greater than  $100,000$  regions/cm<sup>2</sup>, and still more preferably  $10,000,000$  regions/cm<sup>2</sup>.

[0016] In yet another aspect, the present invention provides a material having a useful property prepared by:

forming an array of materials on a single substrate; screening the array for a materials having a useful property; and making additional amounts of the material having the useful property. As such, the present invention provides methods and apparatus for the parallel synthesis and analysis of novel materials having new and useful properties.

[0017] A further understanding of the nature and advantages of the inventions herein may be realized by reference to the remaining portions of the specification and the attached drawings.

#### BRIEF DESCRIPTION OF THE DRAWINGS

[0018] FIG. 1 illustrates an example of a reaction system employing an eight RF magnetron sputtering gun.

[0019] FIG. 2 illustrates masking of a substrate at a first location. The substrate is shown in cross-section;

[0020] FIGS. 3A-3I illustrate the use of binary masking techniques to generate an array of reactants on a single substrate;

[0021] FIGS. 4A-4I illustrate the use of physical masking techniques to generate an array of reactants on a single substrate;

[0022] FIGS. 5A-5M illustrate the use of physical masking techniques to generate an array of reactants on a single substrate;

[0023] FIG. 6 displays the elements of a typical guided droplet dispenser that may be used to delivery the reactant solution of the present invention;

[0024] FIG. 7 illustrates an example of a Scanning RF Susceptibility Detection System which can be used to detect the superconductivity of an array of materials;

[0025] FIG. 8 is a map of the reactant components delivered to the 16 predefined regions on the MgO substrate;

[0026] FIG. 8 is a photograph of the array of 16 different compounds on the 1.25 cm×1.25 cm MgO substrate; and

[0027] FIGS. 10A-10B illustrate the resistance of the two conducting materials as a function of temperature.

#### DETAILED DESCRIPTION OF THE INVENTION AND PREFERRED EMBODIMENTS CONTENTS

[0028] I. Glossary

[0029] II. General Overview

[0030] III. Isolation of Reaction Regions on the Substrate

[0031] IV. Methods for Delivery of Reactant Components

[0032] A. Delivery Using Thin-Film Deposition Techniques

[0033] B. Delivery Using a Dispenser

[0034] V. Moving the Dispenser with Respect to the Substrate

[0035] VI. Synthetic Routes for Reacting the Array of Components

[0036] VII. Methods for Screening an Array of Materials

[0037] VIII. Alternative Embodiments

[0038] IX. Examples

[0039] A. Synthesis of an Array of Copper Oxide Thin-Film Materials

[0040] B. Synthesis of an Array of 16 Different Organic Polymers

[0041] C. Synthesis of an Array of Different Zeolites

[0042] D. Synthesis of an Array of Copper Oxide Compounds Using Spraying Deposition Techniques

[0043] E. Synthesis of an Array of Manganese Oxide Thin-Film Materials

[0044] X. Conclusion

[0045] I. Glossary

[0046] The following terms are intended to have the following general meanings as they are used herein.

[0047] 1. Substrate: A material having a rigid or semi-rigid surface. In many embodiments, at least one surface of the substrate will be substantially flat, although in some embodiments it may be desirable to physically separate synthesis regions for different materials with, for example, dimples, wells, raised regions, etched trenches, or the like. In some embodiments, the substrate itself contains wells, raised regions, etched trenches, etc. which form all or part of the synthesis regions. According to other embodiments, small beads or pellets may be provided on the surface within dimples or on other regions of the surface or, alternatively, the small beads or pellets may themselves be the substrate.

[0048] 2. Predefined Region: A predefined region is a localized area on a substrate which is, was, or is intended to be used for formation of a selected material and is otherwise referred to herein in the alternative as "known" region, "reaction" region, a "selected" region, or simply a "region." The predefined region may have any convenient shape, e.g., circular, rectangular, elliptical, wedge-shaped, etc. Additionally, the predefined region, i.e., the reaction site, can be a bead or pellet which is coated with a reactant component(s) of interest. In this embodiment, the bead or pellet can be identified with a tag, such as an etched binary bar code that can be used to indicate the history of the bead or pellet, i.e., to identify which components were deposited thereon. In some embodiments, a predefined region and, therefore, the area upon which each distinct material is synthesized is smaller than about 25 cm<sup>2</sup>, preferably less than 10 cm<sup>2</sup>, more preferably less than 5 cm<sup>1</sup>, even more preferably less than 1 cm<sup>2</sup>, still more preferably less than 1 mm<sup>2</sup>, and even more preferably less than 0.5 mm<sup>2</sup>. In most preferred embodiments, the regions have an area less than about 10,000 cm<sup>2</sup>, preferably less than 1,000 μm<sup>2</sup>, more preferably less than 100 μm<sup>2</sup>, and even more preferably less than 10 cm<sup>2</sup>.



- [0049] 3. Radiation: Energy which may be selectively applied including energy having a wavelength between  $10^{-14}$  and  $10^4$  meters including, for example, electron beam radiation, gamma radiation, x-ray radiation, ultraviolet radiation, visible light, infrared radiation, microwave radiation and radio waves. "Irradiation" refers to the application of radiation to a surface.
- [0050] 4. Component: "Component" is used herein to refer to each of the individual chemical substances that act upon one another to produce a particular material and is otherwise referred to herein in the alternative as "reactant" or "reactant component." That is to say, the components or, alternatively, reactants are the molecules that act upon one another to produce a new molecule(s), i.e., product(s); for example, in the reaction  $\text{HCl} + \text{NaOH} \rightarrow \text{NaCl} + \text{H}_2\text{O}$ , the HCl and the NaOH are the components or reactants.
- [0051] 5. Material: The term "material" is used herein to refer to solid-state compounds, extended solids, extended solutions, clusters of molecules or atoms, crystals, etc.
- [0052] 6. Covalent Network Solids: Solids that consist of atoms held together in a large network of chains by covalent bonds. Such covalent network solids include, but are not limited to, diamond, silicon nitride, graphite, buckminsterfullerene and organic polymers which cannot be synthesized in a stepwise fashion.
- [0053] 7. Ionic Solids: Solids which can be modeled as cations and anions held together by electrical attraction of opposite charge. Such ionic solids include, but are not restricted to,  $\text{CaF}_2$ ,  $\text{CdCl}_2$ ,  $\text{ZnCl}_2$ ,  $\text{NaCl}$ ,  $\text{AgF}$ ,  $\text{AgCl}$ ,  $\text{AgBr}$  and spinels (e.g.,  $\text{ZnAl}_2\text{O}_4$ ,  $\text{MgAl}_2\text{O}_4$ ,  $\text{FeCr}_2\text{O}_4$ , etc.).
- [0054] 8. Molecular Solids: Solids consisting of atoms or molecules held together by intermolecular forces. Molecular solids include, but are not limited to, extended solids, solid neon, organic compounds, synthetic or organic metals (e.g., tetrathiafulvalene-tetracyanoquinodimethane (TTF-TCNQ)), liquid crystals (e.g., cyclic siloxanes) and protein crystals.
- [0055] 9. Inorganic Materials: Materials which do not contain carbon as a principal element. The oxides and sulphides of carbon and the metallic carbides are considered inorganic materials. Examples of inorganic compounds which can be synthesized using the methods of the present invention include, but are not restricted to, the following:
- [0056] (a) Intermetallics (or Intermediate Constituents): Intermetallic compounds constitute a unique class of metallic materials that form long-range ordered crystal structures below a critical temperature. Such materials form when atoms of two metals combine in certain proportions to form crystals with a different structure from that of either of the two metals (e.g., NiAl,  $\text{CrBc}_2$ , CuZn, etc.).
- [0057] (b) Metal Alloys: A substance having metallic properties and which is composed of a mixture of two or more chemical elements of which at least one is a metal.
- [0058] (c) Magnetic Alloys: An alloy exhibiting ferromagnetism such as silicon iron, but also iron-nickel alloys, which may contain small amounts of any of a number of other elements (e.g., copper, aluminum, chromium, molybdenum, vanadium, etc.), and iron-cobalt alloys.
- [0059] (d) Ceramics: Typically, a ceramic is a metal oxide, boride, carbide, nitride, or a mixture of such materials. In addition, ceramics are inorganic, non-metallic products that are subjected to high temperatures (i.e., above visible red,  $540^\circ\text{C}$ . to  $1000^\circ\text{C}$ .) during manufacture or use. Such materials include, for example, alumina, zirconium, silicon carbide, aluminum nitride, silicon nitride, the  $\text{YBaCu}_3\text{O}_{7-8}$  superconductor, ferrite ( $\text{BaFe}_{12}\text{O}_{19}$ ), Zeolite A ( $\text{Na}_{12}[(\text{SiO}_2)_{12}(\text{AlO}_2)] \cdot 27\text{H}_2\text{O}$ ), soft and permanent magnets, etc. High temperature superconductors are illustrative of materials that can be formed and screened using the present invention. "High temperature superconductors" include, but are not restricted to, the  $\text{La}_{2-x}\text{Sr}_x\text{CuO}_4$  superconductors, the  $\text{Bi}_2\text{CaSr}_2\text{Cu}_2\text{O}_{8+x}$  superconductors, the  $\text{Ba}_{1-x}\text{BiO}_3$  superconductors and the ReBaCu superconductors. Such high temperature superconductors will, when they have the desired properties, have critical temperatures above  $30^\circ\text{K}$ , preferably above  $50^\circ\text{K}$ , and more preferably above  $70^\circ\text{K}$ .
- [0060] 10. Organic Materials: Compounds, which generally consist of carbon and hydrogen, with or without oxygen, nitrogen or other elements, except those in which carbon does not play a critical role (e.g., carbonate salts). Examples of organic materials which can be synthesized using the methods of the present invention include, but are not restricted to, the following: (a) Non-biological, organic polymers: Nonmetallic materials consisting of large macromolecules composed of many repeating units. Such materials can be either natural or synthetic, cross-linked or non-crosslinked, and they may be homopolymers, copolymers, or higher-ordered polymers (e.g., terpolymers, etc.). By "non-biological,"  $\alpha$ -amino acids and nucleotides are excluded. More particularly, "non-biological, organic polymers" exclude those polymers which are synthesized by a linear, stepwise coupling of building blocks. Examples of polymers which can be prepared using the methods of the present invention include, but are not limited to, the following: polyurethanes, polyesters, polycarbonates, polyethyleneimines, polyacetates, polystyrenes, polyamides, polyanilines, polyacetylenes, polypyrroles, etc.
- [0061] 11. Organometallic Materials: A class of compounds of the type R-M, wherein carbon atoms are linked directly with metal atoms (e.g., lead tetraethyl ( $\text{Pb}(\text{C}_2\text{H}_5)_4$ ), sodium phenyl ( $\text{C}_6\text{H}_5\text{Na}$ ), zinc dimethyl ( $\text{Zn}(\text{CH}_3)_2$ ), etc.).
- [0062] 12. Composite Materials: Any combination of two materials differing in form or composition on a macroscale. The constituents of composite materials retain their identities, i.e., they do not dissolve or merge completely into one another although they act in concert. Such composite materials may be inorganic, organic or a combination thereof. Included within this

definition are, for example, doped materials, dispersed metal catalysts and other heterogeneous solids.

## [0063] II. General Overview

[0064] The present invention provides methods and apparatus for the preparation and use of a substrate having an array of materials in predefined regions thereon. The invention is described herein primarily with regard to the preparation of inorganic materials, but can readily be applied in the preparation of other materials. Materials which can be prepared in accordance with the methods of the present invention include, for example, covalent network solids, ionic solids and molecular solids. More particularly, materials which can be prepared in accordance with the methods of the present invention include, but are not limited to, inorganic materials, intermetallic materials, metal alloys, ceramic materials, organic materials, organometallic materials, non-biological organic polymers, composite materials (e.g., inorganic composites, organic composites, or combinations thereof), or other materials which will be apparent to those of skill in the art upon review of this disclosure.

[0065] The resulting substrate having an array of materials thereon will have a variety of uses. For example, once prepared, the substrate can be screened for materials having useful properties. Accordingly, the array of materials is preferably synthesized on a single substrate. By synthesizing the array of materials on a single substrate, screening the array for materials having useful properties is more easily carried out. Alternatively, however, the array of materials can be synthesized on a series of beads or pellets by depositing on each bead or pellet the components of interest. In this embodiment, each bead or pellet will have a tag which indicates the history of components deposited thereon as well as their stoichiometries. The tag can, for example, be a binary tag etched into the surface of the bead so that it can be read using spectroscopic techniques. As with the single substrate having an array of materials thereon, each of the individual beads or pellets can be screened for useful properties.

[0066] Properties which can be screened for include, for example, electrical, thermal mechanical, morphological, optical, magnetic, chemical, etc. More particularly, properties which can be screened for include, for example, conductivity, super-conductivity, resistivity, thermal conductivity, anisotropy, hardness, crystallinity, optical transparency, magnetoresistance, permeability, frequency doubling, photoemission, coercivity, critical current, or other useful properties which will be apparent to those of skill in the art upon review of this disclosure. Importantly, the synthesizing and screening of a diverse array of materials enables new compositions with new physical properties to be identified. Any material found to possess a useful property can be subsequently prepared on a large-scale. It will be apparent to those of skill in the art that once identified using the methods of the present invention, a variety of different methods can be used to prepare such useful materials on a large or bulk scale with essentially the same structure and properties.

[0067] Generally, the array of materials is prepared by successively delivering components of materials to predefined regions on a substrate, and simultaneously reacting the components to form at least two materials. In one embodiment, for example, a first component of a first material is delivered to a first region on a substrate, and a

first component of a second material is delivered to a second region on the same substrate. Thereafter, a second component of the first material is delivered to the first regions on the substrate, and a second component of the second material is delivered to the second region on the substrate. Each component can be delivered in either a uniform or gradient fashion to produce either a single stoichiometry or, alternatively, a large number of stoichiometries within a single predefined region. Moreover, reactants can be delivered as amorphous films, epitaxial films, or lattice or superlattice structures. The process is repeated, with additional components, to form a vast array of components at predefined, i.e., known, locations on the substrate. Thereafter, the components are simultaneously reacted to form at least two materials. As explained hereinbelow, the components can be sequentially or simultaneously delivered to predefined regions on the substrate using any of a number of different delivery techniques.

[0068] In the methods of the present invention, the components, after being delivered to predefined regions on the substrate, can be reacted using a number of different synthetic routes. For example, the components can be reacted using, for example, solution based synthesis techniques, photochemical techniques, polymerization techniques, template directed synthesis techniques, epitaxial growth techniques, by the sol-gel process, by thermal, infrared or microwave heating, by calcination, sintering or annealing, by hydrothermal methods, by flux methods, by crystallization through vaporization of solvent, etc. Other useful synthesis techniques that can be used to simultaneously react the components of interest will be readily apparent to those of skill in the art.

[0069] Since the reactions are conducted in parallel, the number of reaction steps can be reduced. Moreover, the reaction conditions at different reaction regions can be controlled independently. As such, reactant amounts, reactant solvents, reaction temperatures, reaction times, the rates at which the reactions are quenched, deposition order of reactants, etc. can be varied from reaction region to reaction region on the substrate. Thus, for example, the first component of the first material and the first component of the second material can be the same or different. If the first component of the first material is the same as the first component of the second materials, this component can be offered to the first and second regions on the substrate at either the same or different concentrations. This is true as well for the second component of the first material and the second component of the second material, etc. As with the first component of the first and second materials, the second component of the first material and the second component of the second material can be the same or different and, if the same, this component can be offered to the first and second regions on the substrate at either the same or different concentrations. Moreover, within a given predefined region on the substrate, the component can be delivered in either a uniform or gradient fashion. If the same components are delivered to the first and second regions of the substrate at identical concentrations, then the reaction conditions (e.g., reaction temperatures, reaction times, etc.) under which the reactions are carried out can be varied from reaction region to reaction region.

[0070] Moreover, in one embodiment of the present invention, a method is provided for forming at least two different arrays of materials by delivering substantially the same

reactant components at substantially identical concentrations to reaction regions on both first and second substrates and, thereafter, subjecting the components on the first substrate to a first set of reaction conditions and the components on the second substrate to a second set of reaction conditions in a wide array of compositions. Using this method, the effects of the various reaction parameters can be studied and, in turn, optimized. Reaction parameters which can be varied include, for example, reactant amounts, reactant solvents, reaction temperatures, reaction times, the pressures at which the reactions are carried out, the atmospheres in which the reactions are conducted, the rates at which the reactions are quenched, the order in which the reactants are deposited, etc. Other reaction parameters which can be varied will be apparent to those of skill in the art.

[0071] The reactant components in the individual reaction regions must often be prevented from moving to adjacent reaction regions. Most simply, this can be ensured by leaving a sufficient amount of space between the regions on the substrate so that the various components cannot interdiffuse between reaction regions. Moreover, this can be ensured by providing an appropriate barrier between the various reaction regions on the substrate. In one approach, a mechanical device or physical structure defines the various regions on the substrate. A wall or other physical barrier, for example, can be used to prevent the reactant components in the individual reaction regions from moving to adjacent reaction regions. This wall or physical barrier may be removed after the synthesis is carried out. One of skill in the art will appreciate that, at times, it may be beneficial to remove the wall or physical barrier before screening the array of materials.

[0072] In another approach, a hydrophobic material, for example, can be used to coat the region surrounding the individual reaction regions. Such materials prevent aqueous (and certain other polar) solutions from moving to adjacent reaction regions on the substrate. Of course, when non-aqueous or nonpolar solvents are employed, different surface coatings will be required. Moreover, by choosing appropriate materials (e.g., substrate material, hydrophobic coatings, reactant solvents, etc.), one can control the contact angle of the droplet with respect to the substrate surface. Large contact angles are desired because the area surrounding the reaction region remains unwetted by the solution within the reaction region.

[0073] In the delivery systems of the present invention, a small, precisely metered amount of each reactant component is delivered into each reaction region. This may be accomplished using a variety of delivery techniques, either alone or in combination with a variety of masking techniques. For example, thin-film deposition techniques in combination with physical masking or photolithographic techniques can be used to deliver the various reactants to selected regions on the substrate. More particularly, sputtering systems, spraying techniques, laser ablation techniques, electron beam or thermal evaporation, ion implantation or doping techniques, chemical vapor deposition (CVD), as well as other techniques used in the fabrication of integrated circuits and epitaxially grown materials can be applied to deposit highly uniform layers of the various reactants on selected regions of the substrate. Alternatively, by varying the relative geometries of the mask, target and/or substrate, a gradient of components can be deposited within each predefined regions

on the substrate or, alternatively, over all of the predefined regions on the substrate. Such thin-film deposition techniques are generally used in combination with masking techniques to ensure that the reactant components are being delivered only to the reaction regions of interest.

[0074] Moreover, in addition to the foregoing, the various reactant components can be deposited into the reaction regions of interest from a dispenser in the form of droplets or powder. Conventional micropipetting apparatus can, for example, be adapted to dispense droplet volumes of 5 nanoliters or smaller from a capillary. Such droplets can fit within a reaction region having a diameter of 300  $\mu\text{m}$  or less when a mask is employed. The dispenser can also be of the type employed in conventional ink-jet printers. Such ink-jet dispenser systems include, for example, the pulse pressure type dispenser system, the bubble jet type dispenser system and the slit jet type dispenser system. These ink-jet dispenser systems are able to deliver droplet volumes as small as 5 picoliters. Moreover, such dispenser systems can be manual or, alternatively, they can be automated using, for example, robotics techniques.

[0075] The dispenser of the present invention can be aligned with respect to the appropriate reaction regions by a variety of conventional systems. Such systems, which are widely used in the microelectronic device fabrication and testing arts, can deliver droplets to individual reaction regions at rates of up to 5,000 drops per second. The translational (X-Y) accuracy of such systems is well within 1  $\mu\text{m}$ . The position of the dispenser stage of such systems can be calibrated with respect to the position of the substrate by a variety of methods known in the art. For example, with only one or two reference points on the substrate surface, a "dead reckoning" method can be provided to locate each reaction region of the array. The reference marks in any such systems can be accurately identified by using capacitive, resistive or optical sensors. Alternatively, a "vision" system employing a camera can be employed.

[0076] In another embodiment of the present invention, the dispenser can be aligned with respect to the reaction region of interest by a system analogous to that employed in magnetic and optical storage media fields. For example, the reaction region in which the component is to be deposited is identified by its track and sector location on the disk. The dispenser is then moved to the appropriate track while the disk substrate rotates. When the appropriate reaction region is positioned below the dispenser, a droplet of reactant solution is released.

[0077] In some embodiments, the reaction regions may be further defined by dimples in the substrate surface. This will be especially advantageous when a head or other sensing device must contact or glide along the substrate surface. The dimples may also act as identification marks directing the dispenser to the reaction region of interest.

### [0078] III. Isolation of Reaction Regions on a Substrate

[0079] In a preferred embodiment, the methods of the present invention are used to prepare an array of diverse materials at known locations on a single substrate surface. Essentially, any conceivable substrate can be employed in the invention. The substrate can be organic, inorganic, biological, nonbiological, or a combination of any of these, existing as particles, strands, precipitates, gels, sheets, tub-

ing, spheres, containers, capillaries, pads, slices, films, plates, slides, etc. The substrate can have any convenient shape, such a disc, square, sphere, circle, etc. The substrate is preferably flat, but may take on a variety of alternative surface configurations. For example, the substrate may contain raised or depressed regions on which the synthesis of diverse materials takes place. The substrate and its surface preferably form a rigid support on which to carry out the reaction described herein. The substrate may be any of a wide variety of materials including, for example, polymers, plastics, pyrex, quartz, resins, silicon, silica or silica-based materials, carbon, metals, inorganic glasses, inorganic crystals, membranes, etc. Other substrate materials will be readily apparent to those of skill in the art upon review of this disclosure. Surfaces on the solid substrate can be composed of the same materials as the substrate or, alternatively, they can be different, i.e., the substrates can be coated with a different material. Moreover, the substrate surface can contain thereon an adsorbent (for example, cellulose) to which the components of interest are delivered. The most appropriate substrate and substrate-surface materials will depend on the class of materials to be synthesized and the selection in any given case will be readily apparent to those of skill in the art.

**[0080]** In some embodiments, a predefined region on the substrate and, therefore, the area upon which each distinct material is synthesized is smaller than about  $25 \text{ cm}^2$ , preferably less than  $10 \text{ cm}^2$ , more preferably less than  $5 \text{ cm}^2$ , even more preferably  $1 \text{ cm}^2$ , still more preferably less than  $1 \text{ mm}^2$ , and still more preferably less than  $0.5 \text{ mm}^2$ . In most preferred embodiments, the regions have an area less than about  $10,000 \mu\text{m}^2$ , preferably less than  $1,000 \mu\text{m}^2$ , more preferably less than  $100 \mu\text{m}^2$ , and even more preferably less than  $10 \mu\text{m}^2$ .

**[0081]** In preferred embodiments, a single substrate has at least 10 different materials and, more preferably, at least 100 different materials synthesized thereon. In even more preferred embodiments, a single substrate has more than  $10^3$ ,  $10^4$ ,  $10^5$ ,  $10^6$ , or more materials synthesized thereon. In some embodiments, the delivery process is repeated to provide materials with as few as two components, although the process may be readily adapted to form materials having 3, 4, 5, 6, 7, 8 or more components therein. The density of regions per unit area will be greater than 0.04 regions/ $\text{cm}^2$ , more preferably greater than 0.1 regions/ $\text{cm}^2$ , even more preferably greater than 1 region/ $\text{cm}^2$ , even more preferably greater than 10 regions/ $\text{cm}^2$ , and still more preferably greater than 100 regions/ $\text{cm}^2$ . In most preferred embodiments, the density of regions per unit area will be greater than 1,000 regions/ $\text{cm}^2$ , more preferably 10,000 regions/ $\text{cm}^2$ , even more preferably greater than 100,000 regions/ $\text{cm}^2$ , and still more preferably 10,000,000 regions/ $\text{cm}^2$ .

**[0082]** In other embodiments, the substrate can be a series of small beads or pellets (hereinafter "beads"). The number of beads used will depend on the number of materials to be synthesized and can range anywhere from 2 to an infinite number of beads. In this embodiment, each of the beads is uniformly coated with the reactant component(s) of interest and, thereafter, reacted. This is readily done, for example, by using a series of vessels each of which contains a solution of a particular reactant component. The beads are equally divided into groups corresponding to the number of components used to generate the array of materials. Each group

of beads is then added to one of the vessels wherein a coating of one of the components in solution forms on the surface of each bead. The beads are then pooled together into one group and heated to produce a dry component layer on the surface of each of the beads. The process is repeated several times to generate an array of different reaction components on each of the beads. Once the components of interest have been deposited on the beads, the beads are reacted to form an array of materials. All of the beads may or may not be reacted under the same reaction conditions. To determine the history of the components deposited on a particular bead, mass spectroscopic techniques can be used. Alternatively, each bead can have a tag which indicates the history of components deposited thereon as well as their stoichiometries. The tag can be, for example, a binary tag etched into the surface of the bead so that it can be read using spectroscopic techniques. As with the single substrate having an array of materials thereon, each of the individual beads or pellets can be screened for materials having useful properties.

**[0083]** More particularly, if an array of materials is to be generated based on Bi, Cu, Ca and Si using a series of beads as the substrate, for example, four vessels containing aqueous solutions of  $\text{Bi}(\text{NO}_3)_3$ ,  $\text{Cu}(\text{NO}_3)_3$ ,  $\text{Ca}(\text{NO}_3)_3$  and  $\text{Si}(\text{NO}_3)_3$  would be employed. A portion of the beads are added to the vessel containing the  $\text{Bi}(\text{NO}_3)_3$  solution; a portion of the beads are added to the  $\text{Cu}(\text{NO}_3)_3$  solution; a portion of the beads are added to the vessel containing the  $\text{Ca}(\text{NO}_3)_3$  solution; and, finally, a portion of the beads are added to the vessel containing the  $\text{Si}(\text{NO}_3)_3$  solution. Once the beads are uniformly coated with the component contained in the vessel, the beads are removed from the vessel, dried, etched, pooled together into one group and, thereafter, subsequently divided and added to the vessels containing the foregoing reactant components of interest. The process is optionally repeated, with additional components, to form a vast array of components on each of the beads. It will be readily apparent to those of skill in the art that a number of variations can be made to this technique to generate a vast array of beads containing a vast array of components thereon. For example, some of the beads can be coated with only two components, others with more than two components. Additionally, some of the beads can be coated two or more times with the same components, whereas other beads are coated a single time with a given component.

**[0084]** As previously explained, the substrate is preferably flat, but may take on a variety of alternative surface configurations. Regardless of the configuration of the substrate surface, it is imperative that the reactant components in the individual reaction regions be prevented from moving to adjacent reaction regions. Most simply, this can be ensured by leaving a sufficient amount of space between the regions on the substrate so that the various components cannot interdiffuse between reaction regions. Moreover, this can be ensured by providing an appropriate barrier between the various reaction regions on the substrate. A mechanical device or physical structure can be used to define the various regions on the substrate. For example, a wall or other physical barrier can be used to prevent the reactant components in the individual reaction regions from moving to adjacent reaction regions. Alternatively, a dimple or other recess can be used to prevent the reactant components in the individual reaction regions from moving to adjacent reaction regions.

[0085] If the substrate used in the present invention is to contain dimples or other recesses, the dimples must be sufficiently small to allow close packing on the substrate. Preferably, the dimples will be less than 1 mm in diameter, preferably less than 0.5 mm in diameter, more preferably less than 10,000  $\mu\text{m}$  in diameter, even more preferably less than 100  $\mu\text{m}$  in diameter, and still more preferably less than 25  $\mu\text{m}$  in diameter. The depth of such dimples will preferably be less than 100  $\mu\text{m}$  and more preferably less than 25  $\mu\text{m}$  below the upper surface of the substrate.

[0086] Dimples having these characteristics can be produced by a variety of techniques including laser, pressing, or etching techniques. A suitable dimpled substrate surface can, for example, be provided by pressing the substrate with an imprinted "master" such as those commonly used to prepare compact optical disks. In addition, an isotropic or anisotropic etching technique employing photolithography can be employed. In such techniques, a mask is used to define the reaction regions on the substrate. After the substrate is irradiated through the mask, selected regions of the photoresist are removed to define the arrangement of reaction regions on the substrate. The dimples may be cut into the substrate with standard plasma or wet etching techniques. If the substrate is a glass or silicon material, suitable wet etch materials can include hydrogen fluoride, or other common wet etchants used in the field of semiconductor device fabrication. Suitable plasma etchants commonly used in the semiconductor device fabrication field can also be employed. Such plasma etchants include, for example, mixtures of halogen containing gases and inert gases. Typically, a plasma etch will produce dimples having a depth of less than 10  $\mu\text{m}$ , although depths of up to 50  $\mu\text{m}$  may be obtained under some conditions.

[0087] Another method for preparing a suitably dimpled surface employs photochemically etchable glass or polymer sheets. For example, a photochemically etchable glass known as "FOTOFORM" is available from Corning Glass Company (New York). Upon exposure to radiation through a mask, the glass becomes soluble in aqueous solutions. Thereafter, the exposed glass is simply washed with the appropriate solution to form the dimpled surface. With this material, well-defined dimples can be made having aspect ratios of 10 to 1 (depth to diameter) or greater, and depths of up to 0.1 inches. Dimple diameters can be made as small as 25  $\mu\text{m}$  in a 250  $\mu\text{m}$  thick glass layer. Moreover, the dimpled surface can contain thereon an adsorbent (for example, cellulose) to which the components of interest are delivered.

[0088] Even when a dimpled surface is employed, it is often important to ensure that the substrate material is not wetted beyond the reaction region parameters. Most simply, this can be ensured by leaving a sufficient amount of space between the regions on the substrate so that the various components cannot interdiffuse between reaction regions. In addition, other techniques can be applied to control the physical interactions that affect wetting, thereby ensuring that the solutions in the individual reaction regions do not wet the surrounding surface and contaminate other reaction regions. Whether or not a liquid droplet will wet a solid surface is governed by three tensions: the surface tension at the liquid-air interface, the interfacial tension at the solid-liquid interface and the surface tension at the solid-air interface. If the sum of the liquid-air and liquid-solid ten-

sions is greater than the solid-air tension, the liquid drop will form a bead (a phenomenon known as "lensing"). If, on the other hand, the sum of the liquid-air and liquid-solid tensions is less than the solid-air tension, the drop will not be confined to a given location, but will instead spread over the surface. Even if the surface tensions are such that the drop will not spread over the surface, the contact or wetting angle (i.e., the angle between the edge of the drop and the solid substrate) may be sufficiently small that the drop will cover a relatively large area (possibly extending beyond the confines of a given reaction region). Further, small wetting angles can lead to formation of a thin (approximately 10 to 20 Å) "precursor film" which spreads away from the liquid bead. Larger wetting angles provide "taller" beads that take up less surface area on the substrate and do not form precursor films. Specifically, if the wetting angle is greater than about 90°, a precursor film will not form.

[0089] Methods for controlling chemical compositions arid, in turn, the local surface free energy of a substrate surface include a variety of techniques apparent to those in the art. Chemical vapor deposition and other techniques applied in the fabrication of integrated circuits can be applied to deposit highly uniform layers on selected regions of the substrate surface. If, for example, an aqueous reactant solution is used, the region inside the reaction regions may be hydrophilic, while the region surrounding the reaction regions may be hydrophobic. As such, the surface chemistry can be varied from position to position on the substrate to control the surface free energy and, in turn, the contact angle of the drops of reactant solution. In this manner, an array of reaction regions can be defined on the substrate surface.

[0090] Moreover, as previously explained, the reactant components in the individual reaction regions can be prevented from moving to adjacent reaction regions by leaving a sufficient amount of space between the regions on the substrate so that the various components cannot interdiffuse between reaction regions.

[0091] IV. Methods for Delivery of Reactant Components

[0092] In the delivery systems of the present invention, a small, precisely metered amount of each reactant component is delivered into each reaction region. This may be accomplished using a variety of delivery techniques, either alone or in combination with a variety of physical masking or photolithographic techniques. Delivery techniques which are suitable for use in the methods of the present invention can generally be broken down into those involving the use of thin-film deposition techniques and those involving the use of a dispenser.

[0093] A. Delivery Using Thin-Film Deposition Techniques

[0094] Thin-film deposition techniques in combination with physical masking or photolithographic techniques can be used to deposit thin-films of the various reactants on predefined regions on the substrate. Such thin-film deposition techniques can generally be broken down into the following four categories: evaporative methods, glow-discharge processes, gas-phase chemical processes, and liquid-phase chemical techniques. Included within these categories are, for example, sputtering techniques, spraying techniques, laser ablation techniques, electron beam or thermal evaporation techniques, ion implantation or doping techniques,

chemical vapor deposition techniques, as well as other techniques used in the fabrication of integrated circuits. All of these techniques can be applied to deposit highly uniform layers, i.e., thin-films, of the various reactants on selected regions on the substrate. Moreover, by adjusting the relative geometries of the masks, the delivery source and/or the substrate, such thin-film deposition techniques can be used to generate uniform gradients at each reaction region on the substrate or, alternatively, over all of the reaction regions on the substrate. For an overview of the various thin-film deposition techniques which can be used in the methods of the present invention, see, for example, *Handbook of Thin-Film Deposition Processes and Techniques*, Noyes Publication (1988), which is incorporated herein by reference for all purposes.

[0095] Thin-films of the various reactants can be deposited on the substrate using evaporative methods in combination with physical masking techniques. Generally, in thermal evaporation or vacuum evaporation methods, the following sequential steps take place: (1) a vapor is generated by boiling or subliming a target material; (2) the vapor is transported from the source to the substrate; and (3) the vapor is condensed to a solid film on the substrate surface. Evaporants, i.e., target materials, which can be used in the evaporative methods cover an extraordinary range of varying chemical reactivity and vapor pressures and, thus, a wide variety of sources can be used to vaporize the target material. Such sources include, for example, resistance-heated filaments, electron beams; crucible heated by conduction, radiation or rf-inductions; arcs, exploding wires and lasers. In preferred embodiments of the present invention, thin-film deposition using evaporative methods is carried out using lasers, filaments, electron beams or ion beams as the source. Successive rounds of deposition, through different physical masks, using evaporative methods generates an array of reactants on the substrate for parallel synthesis.

[0096] Molecular Beam Epitaxy (MBE) is an evaporative method that can be used to grow epitaxial thin-films. In this method, the films are formed on single-crystal substrates by slowly evaporating the elemental or molecular constituents of the film from separate Knudsen effusion source cells (deep crucibles in furnaces with cooled shrouds) onto substrates held at temperatures appropriate for chemical reaction, epitaxy and re-evaporation of excess reactants. The furnaces produce atomic or molecular beams of relatively small diameter, which are directed at the heated substrate, usually silicon or gallium arsenide. Fast shutters are interposed between the sources and the substrates. By controlling these shutters, one can grow superlattices with precisely controlled uniformity, lattice match, composition, dopant concentrations, thickness and interfaces down to the level of atomic layers.

[0097] In addition to evaporative methods, thin-films of the various reactants can be deposited on the substrate using glow-discharge processes in combination with physical masking techniques. The most basic and well known of these processes is sputtering, i.e., the ejection of surface atoms from an electrode surface by momentum transfer from bombarding ions to surface atoms. Sputtering or sputter-deposition is a term used by those of skill in the art to cover a variety of processes. One such process is RF/DC Glow Discharge Plasma Sputtering. In this process, a plasma of energized ions is created by applying a high RF or DC

voltage between a cathode and an anode. The energized ions from the plasma bombard the target and eject atoms which then deposit on a substrate. Ion-Beam Sputtering is another example of a sputtering process which can be used to deposit thin-films of the various reactant components on the substrate. Ion-Beam Sputtering is similar to the foregoing process except the ions are supplied by an ion source and not a plasma. It will be apparent to one of skill in the art that other sputtering techniques (e.g., diode sputtering, reactive sputtering, etc.) and other glow-discharge processes can be used to deposit thin-films on a substrate. Successive rounds of deposition, through different physical masks, using sputtering or other glow-discharge techniques generates an array of reactants on the substrate for parallel synthesis.

[0098] An example of an eight RF magnetron sputtering gun system which can be employed in the methods of the present invention is illustrated in FIG. 1. This system comprises eight RF magnetron sputtering guns 110, each of which contains a reactant component of interest. The eight RF magnetron sputtering guns are located about 3 to about 4 inches above a disk 112 containing thereon eight masking patterns 114 as well as eight film-thickness monitors 116. In this system, the eight RF magnetron sputtering guns as well as the disk are fixed. The substrate 118, however, is coupled to a substrate manipulator 120 which is capable of linear and rotational motion and which engages the substrate with the particular mask of interest so that the substrate is in contact with the mask when the sputtering begins. Combinations of the eight components are generated on the substrate by the sequential deposition of each component through its respective mask. This entire system is used in vacuo.

[0099] In addition to evaporative methods and sputtering techniques, thin-films of the various reactants can be deposited on the substrate using Chemical Vapor Deposition (CVD) techniques in combination with physical masking techniques. CVD involves the formation of stable solids by decomposition of gaseous chemicals using heat, plasma, ultraviolet, or other energy source, of a combination of sources. Photo-Enhanced CVD, based on activation of the reactants in the gas or vapor phase by electromagnetic radiation, usually short-wave ultraviolet radiation, and Plasma-Assisted CVD, based on activation of the reactants in the gas or vapor phase using a plasma, are two particularly useful chemical vapor deposition techniques. Successive rounds of deposition, through different physical masks, using CVD techniques generates an array of reactants on the substrate for parallel synthesis.

[0100] In addition to evaporative methods, sputtering and CVD, thin-films of the various reactants can be deposited on the substrate using a number of different mechanical techniques in combination with physical masking techniques. Such mechanical techniques include, for example, spraying, spinning, dipping, and draining, flow coating, roller coating, pressure-curtain coating, brushing, etc. Of these, the spray-on and spin-on techniques are particularly useful. Sprayers which can be used to deposit thin-films include, for example, ultrasonic nozzle sprayers, air atomizing nozzle sprayers and atomizing nozzle sprayers. In ultrasonic sprayers, disc-shaped ceramic piezoelectric transducers convert electrical energy into mechanical energy. The transducers receive electrical input in the form of a high-frequency signal from a power supply that acts as a combination oscillator/amplifier. In air atomizing sprayers, the nozzles intermix air and

liquid streams to produce a completely atomized spray. In atomizing sprayers, the nozzles use the energy of from a pressurized liquid to atomize the liquid and, in turn, produce a spray. Successive rounds of deposition, through different physical masks, using mechanical techniques such as spraying generates an array of reactants on the substrate for parallel synthesis.

[0101] In addition to the foregoing techniques, photolithographic techniques of the type known in the semiconductor industry can be used. For an overview of such techniques, see, for example, Sze, *VLSI Technology*, McGraw-Hill (1983) and Mead, et al., *Introduction to VLSI Systems*, Addison-Wesley (1980), which are incorporated herein by reference for all purposes. A number of different photolithographic techniques known to those of skill in the art can be used. In one embodiment, for example, a photoresist is deposited on the substrate surface; the photoresist is selectively exposed, i.e., photolyzed; the photolyzed or exposed photoresist is removed; a reactant is deposited on the exposed regions on the substrate; and the remaining unphotolyzed photoresist is removed. Alternatively, when a negative photoresist is used, the photoresist is deposited on the substrate surface; the photoresist is selectively exposed, i.e., photolyzed; the unphotolyzed photoresist is removed; a reactant is deposited on the exposed regions on the substrate; and the remaining photoresist is removed. In another embodiment, a reactant is deposited on the substrate using, for example, spin-on or spin-coating techniques; a photoresist is deposited on top of the reactant; the photoresist is selectively exposed, i.e., photolyzed; the photoresist is removed from the exposed regions; the exposed regions are etched to remove the reactant from those regions; and the remaining unphotolyzed photoresist is removed. As with the previous embodiment, a negative photoresist can be used in place of the positive photoresist. Such photolithographic techniques can be repeated to produce an array of reactants on the substrate for parallel synthesis.

[0102] Using the foregoing thin-film deposition techniques in combination with physical masking or photolithographic techniques, a reactant component can be delivered to all of the predefined regions on the substrate in a uniform distribution (i.e., in the stoichiometry at each predefined region) or, alternatively, in a gradient of stoichiometries. Moreover, multiple reactant components can be delivered to all of the predefined regions on the substrate in a gradient of stoichiometries. For example, a first component can be deposited through a 100-hole mask from left to right as a gradient layer ranging from about 100 Å to about 1,000 Å in thickness. Thereafter, a second component can be deposited through a 100-hole mask from top to bottom as a gradient layer ranging from about 200 Å to about 2,000 Å in thickness. Once the components have been delivered to the substrate, the substrate will contain 100 predefined regions with varying ratios of the two components in each of the predefined regions. In addition, using the foregoing thin-film deposition techniques in combination with physical masking techniques, a reactant component can be delivered to a particular predefined region on the substrate in a uniform distribution or, alternatively, in a gradient of stoichiometries.

[0103] It will be readily apparent to those of skill in the art that the foregoing deposition techniques are intended to illustrate, and not restrict, the ways in which the reactants

can be deposited on the substrate in the form of thin-films. Other deposition techniques known to and used by those of skill in the art can also be used.

[0104] FIG. 2 and FIG. 3 illustrate the use of the physical masking techniques which can be used in conjunctions with the aforementioned thin-film deposition techniques. More particularly, FIG. 2 illustrates one embodiment of the invention disclosed herein in which a substrate 2 is shown in cross-section. The mask 8 can be any of a wide variety of different materials including, for example, polymers, plastics, resins, silicon, metals, inorganic glasses, etc. Other suitable mask materials will be readily apparent to those of skill in the art. The mask is brought into close proximity with, imaged on, or brought directly into contact with the substrate surface as shown in FIG. 2. "Openings" in the mask correspond to regions on the substrate where it is desired to deliver a reactant. Conventional binary masking techniques in which one-half of the mask is exposed at a given time are illustrated hereinbelow. It will be readily apparent to those of skill in the art, however, that masking techniques other than conventional binary masking techniques can be used in the methods of the present invention.

[0105] As shown in FIG. 3A, the substrate 2 is provided with regions 22, 24, 26, 28, 30, 32, 34, 36, 38, 40, 42, 44, 46, 48, 50 and 52. Regions 38, 40, 42, 44, 46, 48, 50 and 52 are masked, as shown in FIG. 3B, and component A is delivered to the exposed regions in the form of a thin-film using, for example, spraying or sputtering techniques, with the resulting structure shown in FIG. 3C. Thereafter, the mask is repositioned so that regions 26, 28, 34, 36, 42, 44, 50 and 52 are masked, as shown in FIG. 3D, and component B is delivered to the exposed regions in the form of a thin-film, with the resulting structure shown in FIG. 3E.

[0106] As an alternative to repositioning the first mask, a second mask can be used and, in fact, multiple masks are frequently required to generate the desired array of reactants. If multiple masking steps are used, alignment of the masks may be performed using conventional alignment techniques in which alignment marks (not shown) are used to accurately overly successive masks with previous patterning steps, or more sophisticated techniques can be used. Moreover, it may be desirable to provide separation between exposed areas to account for alignment tolerances and to ensure separation of reaction sites so as to prevent cross-continuation. In addition, it will be understood by those of skill in the art that the delivery techniques used to deliver the various reactants to the regions of interest can be varied from reactant to reactant, but, in most instances, it will be most practical to use the same deposition technique for each of the reactants.

[0107] After component B has been delivered to the substrate, regions 30, 32, 34, 36, 46, 48, 50 and 52 are masked, as shown in FIG. 3F, using a mask different from that used in the delivery of components A and B. Component C is delivered to the exposed regions in the form of a thin-film, with the resulting structure shown in FIG. 3G. Thereafter, regions 24, 28, 32, 36, 40, 44, 48 and 52 are masked, as shown in FIG. 3H, and component D is delivered to the exposed regions in the form of a thin-film, with the resulting structure shown in FIG. 3I. Once the components of interest have been delivered to appropriate predefined regions on the substrate, they are simultaneously reacted using any of a number of different synthetic routes to form an array of at least two materials.

[0108] As previously mentioned, masking techniques other than conventional binary masking techniques can be employed with the aforementioned thin-film deposition techniques in the methods of the present invention. For example, FIG. 4 illustrates a masking technique which can be employed to generate an array of materials, each consisting of a combination of three different components, formed from a base group of four different components. In non-conventional binary techniques, a separate mask is employed for each of the different components. Thus, in this example, four different masks are employed. As shown in FIG. 4A, the substrate 2 is provided with regions 54, 56, 58 and 60. Region 56 is masked, as shown in FIG. 4B, and component A is delivered to the exposed regions in the form of a thin-film using, for example, spraying or sputtering techniques, with the resulting structure shown in FIG. 4C. Thereafter, a second mask is employed to mask region 54, as shown in FIG. 4D, and component B is delivered to the exposed regions in the form of a thin-film, with the resulting structure shown in FIG. 4E. Thereafter, region 58 is masked using a third mask, as shown in FIG. 4F, and component C is delivered to the exposed regions in the form of a thin-film, with the resulting structure shown in FIG. 4G. Finally, a fourth mask is employed to mask region 60, as shown in FIG. 4H, and component D is delivered to the exposed regions in the form of a thin-film, with the resulting structure shown in FIG. 4I. Once the components of interest have been delivered to appropriate predefined regions on the substrate, they are simultaneously reacted using any of a number of different synthetic routes to form an array of four different materials.

[0109] FIG. 5 illustrates another masking technique which can be employed to generate an array of materials, each consisting of a combination of three different components, formed from a base group of six different components. As shown in FIG. 5A, the substrate 2 is provided with regions 62, 64, 66, 68, 70, 72, 74, 76, 78, 80, 82, 84, 86, 88, 90, 92, 94, 96, 98 and 100. Regions 64, 68, 72, 76, 80, 84, 88, 92, 96 and 100 are masked, as shown in FIG. 5B, and component A is delivered to the exposed regions in the form of a thin-film using, for example, spraying or sputtering techniques, with the resulting structure shown in FIG. 5C. Thereafter, a second mask is employed to mask regions 62, 66, 72, 74, 80, 82, 88, 90, 96 and 98, as shown in FIG. 5D, and component B is delivered to the exposed regions in the form of a thin-film, with the resulting structure shown in FIG. 5E. Thereafter, regions 64, 66, 70, 74, 78, 82, 86, 92, 96, and 100 are masked using a third mask, as shown in FIG. 5F, and component C is delivered to the exposed regions in the form of a thin-film, with the resulting structure shown in FIG. 5G. Thereafter, a fourth mask is employed to mask regions 64, 66, 70, 76, 78, 84, 88, 90, 94 and 98, as shown in FIG. 5H, and component D is delivered to the exposed regions in the form of a thin-film, with the resulting structure shown in FIG. 5I. Thereafter, regions 62, 68, 70, 74, 80, 84, 86, 90, 94 and 100 are masked with a fifth mask, as shown in FIG. 5J, and component E is delivered to the exposed regions in the form of a thin-film, with the resulting structure shown in FIG. 5K. Finally, a sixth mask is employed to mask regions 62, 68, 72, 76, 78, 82, 86, 92, 94 and 98, as shown in FIG. 5L, and component F is delivered to the exposed regions in the form of a thin-film, with the resulting structure shown in FIG. 5M. Once the components of interest have been delivered to appropriate predefined

regions on the substrate, they are simultaneously reacted using any of a number of different synthetic routes to form an array of 20 different materials.

[0110] It will be readily apparent to those of skill in the art that alternative masking techniques can be employed to generate an array of materials, each consisting of a combination of 3 or more components, formed from a base group of four or more components.

#### [0111] B. Delivery Using A Dispenser

[0112] In addition to the foregoing delivery techniques, dispensers can be utilized to generate diverse combinations of reactant components in the form of droplets or powder on a single substrate. As explained above, commercially available micropipetting apparatus can be adapted to dispense droplet volumes of 5 nanoliters or smaller from a capillary. Such droplets can fit within a reaction region having a diameter of 300  $\mu\text{m}$  or less when a non-wetting mask is employed. In some embodiments, the micropipette is accurately and precisely positioned above the reaction, as described below, before the reactant solution is deposited.

[0113] In a different preferred embodiment, the present invention employs a solution depositing apparatus that resembles devices commonly employed in the inkjet printing field. Such inkjet dispensers include, for example, the pulse pressure type, the bubble jet type and the slit jet type. In an ink-jet dispenser of the pulse pressure type, the printing ink is jetted from a nozzle according to a change in pressure applied by a piezoelectric device. In an ink-jet dispenser of the bubble jet type, bubbles are generated with heat generated with a resistance device embedded in a nozzle, and printing ink is jetted by using the force due to the expansion of a bubble. In an ink-jet dispenser of the slit jet type, printing ink is filled within a slit-like orifice wherein recording electrodes are aligned in correspondence to pixels, and a DC voltage pulse is applied between a recording electrode and a counter electrode arranged behind a recording paper. In this system, the printing ink around the top of the record electrode is charged electrically so that the ink is ejected towards the recording paper with an electrostatic force to record a dot on the paper.

[0114] Such ink-jet printers can be used with minor modification by simply substituting a reactant containing solution or reactant containing powder for the ink. For example, Wong, et al., European Patent Application 260 965, incorporated herein by reference for all purposes, describes the use of a pulse pressure type inkjet printer to apply an antibody to a solid matrix. In the process, a solution containing the antibody is forced through a small bore nozzle that is vibrating in a manner that fragments the solution into discrete droplets. The droplets are subsequently charged by passing through an electric field and then deflected onto the matrix material.

[0115] For illustrative purposes, a conventional ink drop printer of the pulse pressure type includes a reservoir in which ink is held under pressure. The ink reservoir feeds a pipe which is connected to a nozzle. An electromechanical transducer is employed to vibrate the nozzle at some suitable high frequency. The actual structure of the nozzle may have a number of different constructions, including a drawn glass tube which is vibrated by an external transducer, or a metal tube vibrated by an external transducer (e.g., a piezoelectric



crystal), or a magnetostrictive metal tube which is magnetostrictively vibrated. The ink accordingly is ejected from the nozzle in a stream which shortly thereafter breaks into individual drops. An electrode may be present near the nozzle to impart a charge to the droplets.

[0116] A schematic drawing of an ink drop dispenser of the pulse pressure type (such as is described in U.S. Pat. Nos. 3,281,860 and 4,121,222, which are incorporated by reference herein for all purposes) which may be employed in the present invention is shown in FIG. 6. This apparatus comprises a reservoir 210 which contains a solution under pressure. Tubing 212 is connected to the reservoir 210 and terminates in a metal nozzle 242. Nozzle 242 is disposed within a hole provided in piezoelectric crystal 240. The end of the metal tube and of the piezoelectric crystal are made to coincide. The tubing and the piezoelectric crystal are soldered together to form a permanent waterproof attachment. The coincident ends of the crystal and the tubing are covered with a washer 244 which is termed an orifice washer. This washer has an opening 246 drilled therethrough through which the solution is emitted under pressure. A source of oscillations 218 is connected between the outside of the metal tubing 242 and the outside of the piezoelectric crystal 240. The construction is such that hermetic sealing can be employed which protects against electrochemical and atmospheric attack of the components.

[0117] The piezoelectric crystal 240 is vibrated substantially at the frequency of the source of oscillations causing the tubing and nozzle to vibrate whereby the solution stream breaks down into droplets 246. A signal source 224 which is synchronized by the source of oscillations is connected between the nozzle and the charging cylinder 226. As a result, each of the drops, which should be substantially the same mass, receives a charge, the amplitude of which is determined by the amplitude of the signal applied from the source 224 and the charging cylinder 226.

[0118] The charged drops, after passing through the charging cylinder, pass into an electric field which is established between two plates respectively 230 and 232 which are connected to a field potential source 234. As a result of the action between the field and the charge of each drop, the drops are deflected from their center line path between the plates in accordance with the charge which they carry. Thus, when they fall on an optionally moving writing medium 236, a deposition pattern occurs on the writing medium representative of the information in the signals.

[0119] Although the inkjet printer of the pulse pressure type has been described in greater detail herein for purposes of illustration, it will be readily apparent to those of skill in the art that inkjet printers of the bubble jet type and the slit jet type can also be used, with only minor modifications, to deliver reactant components to predefined regions on the substrate. Moreover, although the foregoing discussion refers to a single nozzle, it will be readily apparent to those of skill in the art that ink-jet printers having multiple nozzles can be used to deliver multiple reactant components to a single predefined region on the substrate or, alternatively, to multiple predefined regions on the substrate. In addition, as improvements are made in field of ink-jet printers, such improvements can be used in the methods of the present invention.

[0120] In other embodiments, the reactant solutions can be delivered from a reservoir to the substrate by an electro-

phoretic pump. In such a device, a thin capillary connects a reservoir of the reactant with the nozzle of the dispenser. At both ends of the capillary, electrodes are present to provide a potential difference. As is known in the art, the speed at which a chemical species travels in a potential gradient of an electrophoretic medium is governed by a variety of physical properties, including the charge density, size, and shape of the species being transported, as well as the physical and chemical properties of the transport medium itself. Under the proper conditions of potential gradient, capillary dimensions, and transport medium rheology, a hydrodynamic flow will be set up within the capillary. Thus, bulk fluid containing the reactant of interest can be pumped from a reservoir to the substrate. By adjusting the appropriate position of the substrate with respect to the electrophoretic pump nozzle, the reactant solution can be precisely delivered to predefined reaction regions.

[0121] Using the aforementioned dispenser systems, the reactants can be delivered to predefined regions on the substrate either sequentially or simultaneously. In a presently preferred embodiment, the reactants are simultaneously delivered to either a single predefined region on the substrate or, alternatively, to multiple predefined regions on the substrate. For example, using an ink-jet dispenser having two nozzles, two different reactants can be simultaneously delivered to a single predefined region on the substrate. Alternatively, using this same inkjet dispenser, a reactant can be simultaneously delivered to two different predefined regions on the substrate. In this instance, the same reactant or, alternatively, two different reactants can be delivered. If the same reactant is delivered to both of the predefined regions, it can be delivered at either the same or different concentrations. Similarly, using an ink-jet dispenser having eight nozzles, for example, eight different reactants can be simultaneously delivered to a single predefined region on the substrate or, alternatively, eight reactants (either the same or different) can be simultaneously delivered to eight different predefined regions on the substrate.

[0122] V. Moving the Dispenser with Respect to the Substrate

[0123] To deposit reactant droplets consistently at precisely specified regions using a dispenser, a frame of reference common to the delivery instrument and the substrate is required. In other words, the reference coordinates of the instrument must be accurately mapped onto the reference coordinates of the substrate. Ideally, only two reference points on the substrate would be required to completely map the array of reaction regions. The dispenser instrument locates these reference points and then adjust its internal reference coordinates to provide the necessary mapping. After this, the dispenser can move a particular distance in a particular direction and be positioned directly over a known region. Of course, the dispenser instrument must provide precisely repeatable movements. Further, the individual regions of the array must not move with respect to the reference marks on the substrate after the reference marks have been formed. Unfortunately, pressing or other mechanical operations commonly encountered during fabrication and use of a substrate can warp the substrate such that the correspondence between the reference marks and the reaction regions is altered.

[0124] To allow for this possibility, a substrate containing both "global" and "local" reference marks is employed. In

preferred embodiments, only two global reference marks are conveniently located on the substrate to define the initial frame of reference. When these points are located, the dispenser instrument has an approximate map of the substrate and the predefined regions therein. To assist in locating the exact position of the regions, the substrate is further subdivided into local frames of reference. Thus, in an initial, "course" adjustment, the dispenser is positioned within one of the local frames of reference. Once in the local region, the dispensing instrument looks for local reference marks to define further a local frame of reference. From these, the dispenser moves exactly to the reaction region where the reactant is deposited. In this manner, the effects of warpage or other deformation can be minimized. The number of local reference marks is determined by the amount of deformation expected in the substrate. If the substrate is sufficiently rigid so that little or no deformation will occur, very few local reference marks are required. If substantial deformation is expected, however, more local reference marks are required.

[0125] Starting at a single reference point, the micropipette or other dispenser is translated from one reaction region to other reaction regions of the substrate by a correct distance in the correct direction (this is the "dead reckoning" navigational technique). Thus, the dispenser can move from region to region, dispensing correctly metered amounts of reactant. In order to initially locate the reference point and align the dispenser directly over it, a vision or blind system can be employed. In a vision system, a camera is rigidly mounted to the dispenser nozzle. When the camera locates the reference point(s), the dispenser is known to be a fixed distance and direction away from the point, and a frame of reference is established. Blind systems locate the reference point(s) by capacitive, resistive, or optical techniques, for example. In one example of an optical technique, a laser beam is transmitted through or reflected from the substrate. When the beam encounters a reference mark, a change in light intensity is detected by a sensor. Capacitive and resistive techniques are similarly applied. A sensor registers a change in capacitance or resistivity when a reference point is encountered.

[0126] For purposes of this invention, the spacing between the individual regions will vary in accordance with the size of the regions used. For example, if a 1 mm<sup>2</sup> region is used, the spacing between the individual regions will preferably be on the order of 1 mm or less. If, for example, a 10 μm<sup>2</sup> region is used, the spacing between the individual regions will preferably be on the order of 10 μm or less. Further, the angular relation between the cells is preferably consistent, to within 0.1 degrees. Of course, the photolithographic or other process used to define the arrangement of cells will accurately define the angle and spacing. However, in subsequent processes (e.g., pressing processes), the angle can be distorted. Thus, in some embodiments, it may be necessary to employ "local" reference points throughout the array.

[0127] Translational mechanisms capable of moving with the desired precision are preferably equipped with position feedback mechanisms (i.e., encoders) of the type used in devices for semiconductor device manufacturing and testing. Such mechanisms will preferably be closed loop systems with insignificant backlash and hysteresis. In preferred embodiments, the translation mechanism will have a high resolution, i.e., greater than five motor ticks per encoder count. Further, the electro-mechanical mechanism will pref-

erably have a high repeatability relative to the region diameter travel distance (preferably, ±1-5 μm).

[0128] To deposit a drop of reactant solution on the substrate accurately, the dispenser nozzle must be placed a correct distance above the surface. The dispenser tip preferably will be located about 0.1 cm to about 3 cm above the substrate surface when the drop is released. The degree of control necessary to achieve such accuracy can be attained with a repeatable high-resolution translation mechanism of the type described above. In one embodiment, the height above the substrate is determined by moving the dispenser toward the substrate in small increments, until the dispenser tip touches the substrate. At this point, the dispenser is moved away from the surface a fixed number of increments which corresponds to a specific distance. From there, the drop is released to the cell below. Preferably, the increments in which the dispenser moves will vary in accordance with the size of the regions used.

[0129] In an alternative embodiment, the dispenser nozzle is encircled by a sheath that rigidly extends a fixed distance beyond the dispenser tip. Preferably, this distance corresponds to the distance at which the solution drop will fall when delivered to the selected reaction region. Thus, when the sheath contacts the substrate surface, the movement of the dispenser is halted and the drop is released. It is not necessary in this embodiment to move the dispenser back, away from the substrate, after contact is made. In this embodiment, as well as the previous embodiment, the point of contact with the surface can be determined by a variety of techniques such as by monitoring the capacitance or resistance between the tip of the dispenser (or sheath) and the substrate below. A rapid change in either of these properties is observed upon contact with the surface.

[0130] To this point, the dispenser delivery system has been described only in terms of translational movements. However, other systems may also be employed. In one embodiment, the dispenser is aligned with respect to the region of interest by a system analogous to that employed in magnetic and optical storage media fields. For example, the region in which reactant is to be deposited is identified by a track and sector location on the disk. The dispenser is then moved to the appropriate track while the disk substrate rotates. When the appropriate cell is positioned below the dispenser (as referenced by the appropriate sector on the track), a droplet of reactant solution is released.

[0131] Control of the droplet size may be accomplished by various techniques. For example, in one embodiment, a conventional micropipetting instrument is adapted to dispense droplets of five nanoliters or smaller from a capillary. Such droplets fit within regions having diameters of 300 μm or less when a non-wetting mask is employed.

[0132] Although the above embodiments have been directed to systems employing liquid droplets, minuscule aliquots of each test substance can also be delivered to the reaction region as powders or miniature pellets. Pellets can be formed, for example, from the compound of interest and one or more kinds of inert binding material. The composition of such binders and methods for the preparation of the "pellets" will be apparent to those of skill in the art. Such "mini-pellets" will be compatible with a wide variety of test substances, stable for long periods of time and suitable for easy withdrawal from the storage vessel and dispensing.

**[0133]** VI. Synthetic Routes for Reacting the Array of Components

**[0134]** Once the array of components have been delivered to predefined regions on the substrate, they can be simultaneously reacted using a number of different synthetic routes. The components can be reacted using, for example, solution based synthesis techniques, photochemical techniques, polymerization techniques, template directed synthesis techniques, epitaxial growth techniques, by the sol-gel process, by thermal, infrared or microwave heating, by calcination, sintering or annealing, by hydrothermal methods, by flux methods, by crystallization through vaporization of solvent, etc. Other useful synthesis techniques will be apparent to those of skill in the art upon review of this disclosure. Moreover, the most appropriate synthetic route will depend on the class of materials to be synthesized, and the selection in any given case will be readily apparent to those of skill in the art. In addition, it will be readily apparent to those of skill in the art that, if necessary, the reactant components can be mixed using, for example, ultrasonic techniques, mechanical techniques, etc. Such techniques can be applied directly to a given predefined region on the substrate or, alternatively, to all of the predefined regions on the substrate in a simultaneous fashion (e.g., the substrate can be mechanically moved in a manner such that the components are effectively mixed).

**[0135]** Traditional routes to solid-state synthesis involve the sintering of solid reactants. The standard method used to synthesize superconductors, for example, is to grind several metal-oxide powders together, compress the mixture and, thereafter, bake at a temperature ranging from 800° C. to about 1000° C. The elements in the powder mixture sinter, i.e., they react chemically to form new compounds and fuse into a solid, without passing through the liquid or gaseous phase. Gaseous elements, such as oxygen, can be taken up during sintering or, alternatively, in a subsequent step, and the pressure of the system can be varied during the synthesis process. Unfortunately, using traditional sintering techniques, reaction rates are limited by the slow diffusion of atoms or ions through solid reactants, intermediates and products. Moreover, high temperatures are frequently required to accelerate diffusion and to thermodynamically drive the formation of a stable phase.

**[0136]** In contrast to such traditional routes, in the present invention, new routes to solid-synthesis focus on the synthesis of compounds at lower temperatures. It has been found that reaction rates can be increased at lower temperatures by drastically shortening the distance required for diffusion of the reactants and by increasing the surface to volume ratio. This can be achieved by depositing the reactants on the substrate in the form of very thin-films or, alternatively, by using solution based synthesis techniques wherein the reactants are delivered to the substrate in the form of a solution. Moreover, when the synthesis reaction is to be carried out at a temperature ranging from about 200° C. to about 600° C., a molten salt can be employed to dissolve the reactant components. This technique is generally referred to as the flux method. Similarly, in a hydrothermal method, water or other polar solvent containing a soluble inorganic salt is employed to dissolve the reactant components. The hydrothermal method is usually carried out under pressure and at a temperature ranging from about 100° C. to about 400° C. Moreover, using the various

synthetic routes of the present invention, the array of reactant components can be pressurized or depressurized under an inert atmosphere, oxygen or other gas. In addition, in the synthetic routes of the present invention, various regions on the substrate can be exposed to different heat histories using, for example, laser thermolysis, wherein bursts of energy of a predetermined duration and intensity are delivered to target regions on the substrate.

**[0137]** Furthermore, using the synthetic routes of the present invention, the array of components can be processed between the various delivery steps. For example, component A can be delivered to a first region on a substrate and, thereafter, exposed to oxygen at elevated temperature, for example. Subsequently, component B can be delivered to the first region on the substrate and, thereafter, components A and B are reacted under a set of reaction conditions. Other manipulations and processing steps which can be carried out between the various delivery steps will be apparent to those of skill in the art upon reading this disclosure.

**[0138]** As such, using the methods of the present invention, the following materials can be prepared: covalent network solids, ionic solids and molecular solids. More particularly, the methods of the present invention can be used to prepare, for example, inorganic materials, intermetallic materials, metal alloys, ceramic materials, organic materials, organometallic materials, non-biological organic polymers, composite materials (e.g., inorganic composites, organic composites, or combinations thereof), etc. High-temperature superconductors can be prepared, for instance, by delivering reactant components to predefined regions on the substrate using, for example, solution based delivery techniques. Once the reactant components of interest have been delivered to the substrate, the substrate is heated to the boiling point of the solvent to evaporate off the solvent. Alternatively, the solvent can be removed by delivering the reactant components to a heated substrate. The substrate is then oxidized to remove unwanted components (e.g., carbon, nitrogen, etc.) from the array. The substrate is then flash heated at a temperature of about 800° C. to about 875° C. for about two minutes. Thereafter, the reaction is rapidly quenched and the array is scanned for materials that are superconducting. Magnetic materials can be prepared using a similar process except that in the case of magnetic materials, the components are delivered to the substrate and simultaneously reacted thereon in the presence of a magnetic field.

**[0139]** Moreover, an array of zeolites, i.e., hydrated silicates of aluminum and either sodium, calcium or both, can be prepared using the methods of the present invention. To prepare an array of such materials, the reactant components are delivered to predefined regions on a substrate in the form of a slurry. Using a low temperature (e.g., 60° C. to about 70° C.) hydrothermal method, for example, the zeolites will crystallize out of solution. In addition, organic polymers can be prepared by delivering a monomer (or monomers) of interest to predefined regions on the substrate usually in the form of a solution. Once the monomer of interest has been delivered, an initiator is added to each region on the substrate. The polymerization reaction is allowed to proceed until the initiator is used up, or until the reaction is terminated in some other manner. Upon completion of the polymerization reaction, the solvent can be removed by, for example, evaporation in vacuo.

[0140] It will be readily apparent to those of skill in the art that the foregoing synthetic routes are intended to illustrate, and not restrict, the ways in which the reactants can be simultaneously reacted to form at least two materials on a single substrate. Other synthetic routes and other modifications known to and used by those of skill in the art can also be used.

[0141] VII. Methods for Screening the Array of Materials

[0142] Once prepared, the array of materials can be screened in parallel for materials having useful properties. Either the entire array or, alternatively, a section thereof (e.g., a row of predefined regions) can be screened in parallel for materials having useful properties. Scanning detection systems are preferably utilized to screen an array of materials wherein the density of regions per unit area will be greater than 0.04 regions/cm<sup>2</sup>, more preferably greater than 0.1 regions/cm<sup>2</sup>, even more preferably greater than 1 region/cm<sup>2</sup>, even more preferably greater than 10 regions/cm<sup>2</sup>, and still more preferably greater than 100 regions/cm<sup>2</sup>. In most preferred embodiments, scanning detection systems are preferably utilized to screen an array of materials wherein the density of regions per unit area will be greater than 1,000 regions/cm<sup>2</sup>, more preferably 10,000 regions/cm<sup>2</sup>, even more preferably greater than 100,000 regions/cm<sup>2</sup>, and still more preferably 10,000,000 regions/cm<sup>2</sup>.

[0143] Accordingly, in a preferred embodiment, the array of materials is synthesized on a single substrate. By synthesizing the array of materials on a single substrate, screening the array for materials having useful properties is more easily carried out. Properties which can be screened for include, for example, electrical, thermal mechanical, morphological, optical, magnetic, chemical, etc. More particularly, useful properties which can be screened for are set forth in Table I, infra. Any material found to possess a useful property can subsequently be prepared on a large-scale.

[0144] The properties listed in Table I can be screened for using conventional methods and devices known to and used by those of skill in the art. Scanning systems which can be used to screen for the properties set forth in Table I include, but are not limited to, the following: scanning Raman spectroscopy; scanning NMR spectroscopy; scanning probe spectroscopy including, for example, surface potentialometry, tunnelling current, atomic force, acoustic microscopy, shearing-stress microscopy, ultra fast photo excitation, electrostatic force microscope, tunneling induced photo emission microscope, magnetic force microscope, microwave field-induced surface harmonic generation microscope, non-linear alternating-current tunnelling microscopy, near-field scanning optical microscopy, inelastic electron tunneling spectrometer, etc.; optical microscopy in different wavelength; scanning optical ellipsometry (for measuring dielectric constant and multilayer film thickness); scanning Eddy-current microscope; electron (diffraction) microscope, etc.

[0145] More particularly, to screen for conductivity and/or superconductivity, one of the following devices can be used: a Scanning RF Susceptibility Probe, a Scanning RF/Microwave Split-Ring Resonator Detector, or a Scanning Superconductors Quantum Interference Device (SQUID) Detection System. To screen for hardness, a nanoindenter (diamond tip) can, for example, be used. To screen for magnetoresistance, a Scanning RF/Microwave Split-Ring Resonator Detector or a SQUID Detection System can be

used. To screen for crystallinity, infrared or Raman spectroscopy can be used. To screen for magnetic strength and coercivity, a Scanning RF Susceptibility Probe, a Scanning RF/Microwave Split-Ring Resonator Detector, a SQUID Detection System or a Hall probe can be used. To screen for fluorescence, a photodetector can be used. Other scanning systems known to those of skill in the art can also be used.

TABLE I

EXAMPLES OF PROPERTIES WHICH CAN BE SCREENED FOR	
ELECTRICAL:	SUPERCONDUCTIVITY CRITICAL CURRENT CRITICAL MAGNETIC FIELD CONDUCTIVITY RESISTIVITY FOR RESISTIVE FILMS DIELECTRIC CONSTANT DIELECTRIC STRENGTH DIELECTRIC LOSS STABILITY UNDER BIAS POLARIZATION PERMITTIVITY PIEZOELECTRICITY ELECTROMIGRATION
THERMAL:	COEFFICIENT OF EXPANSION THERMAL CONDUCTIVITY TEMPERATURE VARIATION VOLATILITY & VAPOR PRESSURE
MECHANICAL:	STRESS ANISOTROPY ADHESION HARDNESS DENSITY DUCTILITY ELASTICITY POROSITY
MORPHOLOGY:	CRYSTALLINE OR AMORPHOUS MICROSTRUCTURE SURFACE TOPOGRAPHY CRYSTALLITE ORIENTATION
OPTICAL:	REFRACTIVE INDEX ABSORPTION BIREFRINGENCE SPECTRAL CHARACTERISTICS DISPERSION FREQUENCY MODULATION EMISSION
MAGNETIC:	SATURATION FLUX DENSITY MAGNETORESISTANCE MAGNETORESTRICTION COERCIVE FORCE
MAGNETIC: CHEMICAL:	PERMEABILITY COMPOSITION COMPLEXATION ACIDITY-BASICITY CATALYSIS IMPURITIES REACTIVITY WITH SUBSTRATE CORROSION & EROSION RESISTANCE

[0146] The arrays of the present invention can be screened sequentially or, alternatively, they can be screened in parallel using a scanning system. For instance, the array of materials can be sequentially screened for superconductivity using, for example, magnetic decoration (Bitter pattern) and electron holography. Alternatively, the array of materials can be scanned for superconductivity using, for example, a Hall-probe, magnetic force microscopy, SQUID microscopy, a AC susceptibility microscope, a microwave absorption microscope, an Eddy current microscope, etc.

[0147] In a presently preferred embodiment, a scanning detection system is employed. In one embodiment, the

substrate having an array of materials thereon is fixed and the detector has X-Y motion. In this embodiment, the substrate is placed inside a sealed chamber, close to the detector. The detector (e.g., an RF Resonator, a SQUID detector, etc.) is attached to a rigid rod with low thermal conductivity coupled to an X-y positioning table at room temperature with a scanning range of up to 1 inch and a  $2\ \mu\text{m}$  spatial resolution. The position of the detector is controlled using stepping motors (or servomotors) connected to a computer-controlled positioner. The temperature of the detector and the substrate can be lowered via helium exchange gas by liquid helium reservoir located around the chamber. This scanning system can be operated at temperatures ranging from  $600^\circ\text{K}$  down to  $4.2^\circ\text{K}$  (when immersed in liquid helium).

[0148] In another embodiment, the detector is fixed and the substrate having an array of materials thereon has R- $\theta$  motion. In this embodiment, the substrate is placed on a rotating stage (e.g., a spur gear) driven by a gear rack which is coupled to a micrometer and a stepping motor. This rotating stage is located on a cryogenic sliding table which is driven by a separate micrometer and stepping motor system. This system is capable of scanning an area having a 1 inch radius with a  $1\ \mu\text{m}$  spatial resolution. The scanning and probing are controlled through the use of a computer. As with the other embodiment, the temperature of the detector and the substrate can be lowered via helium exchange gas using a liquid helium reservoir located around the chamber. This scanning system can be operated at temperatures ranging from  $600^\circ\text{K}$  down to  $4.2^\circ\text{K}$  (when immersed in liquid helium).

[0149] Using either of the foregoing embodiments, a Scanning RF Susceptibility Detection System can, for example, be used to detect the superconductivity of a large array of materials (see, e.g., FIG. 7). Using photolithographic techniques, a micro (about  $1\times 1\ \text{mm}^2$ ) spiral coil can be fabricated to probe the conductivity of a sample adjacent to the coil. The signals are picked up by a phase-sensitive detection electronic circuit. Thereafter, the data is analyzed by a computer to obtain a correlation between the properties and stoichiometry of a given sample. If desired, analytical results can be fed back to the delivery system so that the system can "zoom in" on the most promising stoichiometry in the next synthesis cycle.

[0150] Moreover, a superconducting microcircuit implementation of a parallel LC resonance circuit can be used to scan the array of materials for those that are superconducting. A parallel LC circuit is simply an inductor in parallel with a capacitor. The electrical properties of both circuit elements give the circuit a resonance frequency where a maximum amount of input voltage is transmitted through to the output. The sharpness of the peak, conventionally measured by its Q value, is determined by the materials used in the circuit, whereas the frequency of the resonance is set by the capacitance and the inductance. It has been determined that manufacturing the circuit out of a superconducting material, such as niobium, gives a very high Q value, i.e., a Q value on the order of 10,000 or more. This is in contrast to commercially available, non-superconducting capacitors and inductors which generally give Q values on the order of hundreds. The steep peak of the niobium circuit gives rise to high sensitive detection.

[0151] In this system, actual detection is done by the induction coil. The inductance of an inductor is a function of the magnetic field geometry through its coils. In the presence of a nearby superconducting sample, the magnetic field through the inductor is distorted by the expulsion of field by the material (i.e., the Meissner effect). This, in turn, changes the inductance and shifts the resonance. By following the resonance, one can readily determine when a material is superconducting.

[0152] In this scanning device, the total circuit is approximately  $5\ \text{mm}\times 2.5\ \text{mm}$ , with an active area equal to approximately one-fourth of that. The coil is a spiral coil having dimensions of about 1.5 mm per side, and the capacitor is a two-plate niobium capacitor with a  $\text{SiO}_2$  dielectric (i.e., insulating) layer SQUID magnetometers have achieved spatial resolutions of  $10\ \mu\text{m}$ , but their sensitivities have been limited by noise present in the Josephson junction. In the scanning device of the present invention, however, the device is unencumbered by noise from the Josephson junction and, thus, a sensitivity for samples of  $1\ \mu\text{m}$  or less can be achieved. In this embodiment, sensitivity, rather than spatial resolution, is a more critical criterion.

[0153] It will be readily apparent to those of skill in the art that the foregoing detection systems are intended to illustrate, and not restrict, the ways in which the array of material can be screened for those materials having useful properties. Other detection systems known to and used by those of skill in the art can similarly be used.

#### [0154] VIII. Alternative Embodiments

[0155] In another embodiment of the present invention, at least two different arrays of materials are prepared by delivering substantially the same reaction components at substantially identical concentrations to predefined regions on both first and second substrates and, thereafter, subjecting the components on the first substrate to a first set of reaction conditions and the components on the second substrate to a second set of reaction conditions in a wide array of compositions. If a first substrate has, for example, components A and B on a first region on the substrate and, in addition, components X and Y on a second region on the substrate, the second substrate is prepared in a manner such that it has substantially the same components in predefined regions. That is to say, the second substrate is substantially identical to the first substrate in terms of the components contained thereon. As such, in this example, the second substrate would also have components A and B on the first region of the substrate and, in addition, components X and Y on the second region on the substrate.

[0156] Once the components have been delivered to their appropriate predefined regions on the substrate, the components on the first substrate are reacted using a first set of reaction conditions, whereas the components on the second substrate are reacted using a second set of reaction conditions. It will be understood by those of skill in the art that the components on the first substrate can be reacted under a first set of reaction conditions at the same time as the components on the second substrate are reacted under a second set of reaction conditions or, alternatively, the components on the first substrate can be reacted under a first set of reaction conditions either before or after the components on the second substrate are reacted under a second set of reaction conditions.

[0157] In this embodiment, the effects of various reaction parameters can be studied and, in turn, optimized. Reaction parameters which can be varied include, for example, reactant amounts, reactant solvents, reaction temperatures, reaction times, the pressures at which the reactions are carried out, the atmospheres in which the reactions are conducted, the rates at which the reactions are quenched, etc. Other reaction parameters which can be varied will be apparent to those of skill in the art. Alternatively, the first set of reaction conditions can be the same as the second set of reaction conditions, but, in this embodiment, the processing steps after the components on the first and second substrates have been reacted would differ from the first substrate to the second substrate. For example, the first substrate can be exposed to oxygen at elevated temperatures, while the second substrate is not processed at all.

[0158] Alternatively, in another aspect of this embodiment, the first substrate having component A on the first region of the substrate and component X on the second region of the substrate is exposed to a particular set of reaction conditions (e.g., exposed to oxygen at elevated temperatures), while the second substrate also having component A on the first region of the substrate and component X on the second region of the substrate is not exposed to such reaction conditions. Thereafter, component B is delivered to the first region of both the first and second substrates, and component Y is delivered to the second region of both the first and second substrates. Once the desired components have been delivered to the first and second regions on the first and second substrates, the components are simultaneously reacted under substantially identical reaction conditions. This particular embodiment allows one to determine the effects intermediate processing steps have on a particular array of materials. As set forth above, any of a number of different reaction parameters can be varied.

[0159] In still another embodiment of the present invention, a method is provided for producing an array of materials varying from one another in terms of chemical composition and component stoichiometries. In this method, a reactant component can be delivered to a particular predefined region(s) in a gradient of stoichiometries. Moreover, multiple reactant components can be delivered to a particular predefined region(s) in a gradient of stoichiometries. For example, a first component of a first material is deposited in a gradient of stoichiometries from left to right on the first reaction region. Thereafter, a first reaction component of a second material is deposited in a gradient of stoichiometries from left to right on the second reaction region. Thereafter, a second component of the first material is deposited in a gradient of stoichiometries from top to bottom on the first reaction region. Thereafter, a second component of the second material is deposited in a gradient of stoichiometries from top to bottom on the second reaction region. Once the components have been delivered to the substrate, the components are simultaneously reacted to form materials varying from one another in terms of chemical composition and chemical stoichiometries.

[0160] In yet another embodiment of the present invention, a material having a useful property is provided. The material is prepared by a process comprising the steps of: (a) forming an array of different materials on a single substrate; (b) screening the array for a material having a useful property; and (c) making additional amounts of the material

having the useful property. Such materials include, for example, intermetallic materials, metal alloys, ceramic materials, organometallic materials, organic polymers, composite materials (e.g., inorganic composites, organic composites, or combinations thereof), etc. In addition, useful properties include, for example, electrical, thermal, mechanical, morphological, optical, magnetic, chemical, etc.

[0161] It will be understood by those of skill in the art that the foregoing discussions directed to the various delivery techniques, synthetic routes, screening methods, etc. are fully applicable to the above embodiments of the present invention.

## IX. EXAMPLES

[0162] The following examples are provided to illustrate the efficacy of the inventions herein.

[0163] A. Synthesis of an Array of Copper Oxide Thin-Film Materials

[0164] This example illustrates the synthesis and screening of an array of copper oxide thin-film materials. The reactants were delivered to a 1.25 cm×1.25 cm MgO substrate with a (100) polished surface. The substrate having 16 predefined regions thereon was contained in a reaction chamber in vacuo. The reactants were delivered to the substrate in the form of thin-films using a sputtering system in combination with binary masking techniques. The binary mask was made of stainless steel. A RF magnetron gun sputtering system was used to deliver the reactant components to the predefined regions on the substrate. The RF magnetron sputtering gun (Mini-mak manufactured by US, Inc., Campbell, Calif.) used was about 1.3 inches in diameter. With RF input power (supplied by a Plasmtherm-2000 with a matching network) of 50 to about 200 W, deposition rates ranged from about 0.3 U/s to about 2 U/s for the five different reactant components. The RF magnetron sprayer was positioned about 3 to 4 inches above the substrate and the uniformity of deposited film was about 5% over a 1 to 2 inch diameter area. The sputtering gas flow (Ar or Ar and O<sub>2</sub>) was controlled by metering valves and differential pumping through a manual gate valve. To achieve a high deposition rate, it was determined that the best gas pressure range was about 5 to 15 mTorr. The partial pressure of each gas component in the chamber was monitored using a residual gas analyzer (Micropole Sensor by Ferran Scientific, San Diego, Calif.) directly up to 15 mTorr without differential pumping.

[0165] The reactant components used to generate the array of copper oxide materials were as follows: CuO, Bi<sub>2</sub>O<sub>3</sub>, CaO, PbO and SrCO<sub>3</sub>. CuO was used as the base element in an effort to discover new copper oxide materials and, thus, this component was delivered to each of the 16 predefined regions on the substrate. Prior to delivering the component of interest to the predefined regions on the substrate, the base air pressure of the reaction chamber was lowered, within 10 to 15 minutes, to about 10<sup>-3</sup> to 10<sup>-4</sup> Torr by a 250 l/s turbo pump and, if necessary, it was further lowered to 10<sup>-8</sup> Torr using extended pumping time in combination with heating the reaction chamber to about 100° C. to about 150° C. Since only a single RF magnetron gun sputtering system was employed, the vacuum was broken and reestablished each time the component was changed. The film deposition

thickness was monitored using a crystal micro-balance (STM-100 by Sycon Instruments, Syracuse, N.Y.). Since the position of crystal micro-balance was not located at exactly the same position as the substrate, it was necessary to calibrate the thickness monitor reading for each component with a profilometer.

[0166] The reactant components were delivered to the MgO substrate in the following order: Bi<sub>2</sub>O<sub>3</sub>, PbO, CuO, CaO and SrCO<sub>3</sub>. The stoichiometry was designed so that each of the five components was present in equal molar amounts, i.e., 1 Bi:1 Pb:1 Cu:1 Sr:1 Ca as deposited film. The total thickness of the film was about 0.5 μm for a five layered site. The thickness of each of the individual films as well as the sputtering rates at which each of the components were deposited are set forth in Table II, supra.

TABLE II

DEPOSITION THICKNESS AND SPUTTERING RATE FOR THE COMPONENTS USED TO GENERATE AN ARRAY OF COPPER OXIDES		
Component	Deposition Thickness	Sputtering Rate
Bi <sub>2</sub> O <sub>3</sub>	1200 Å	2 Å/Sec
PbO	970 Å	1.6 Å/Sec
CuO	540 Å	1 Å/Sec
SrCO <sub>3</sub>	1650 Å	3 Å/Sec
CaO	720 Å	3 Å/Sec

[0167] Once the components of interest were delivered to the 16 predefined regions on the substrate as illustrated in FIG. 8, the substrate was placed in a furnace, and the components were subsequently reacted. FIG. 9 is a photograph of the array of 16 different compounds on the 1.25 cm×1.25 cm MgO substrate. The color of each site is the natural color of reflected light from a white light source at an angle. The components were simultaneously reacted using the following heating and cooling procedure: 50° C. to 725° C. in 2 hr., 725° C. to 820° C. in 1 hr., 820° C. to 840° C. in 0.5 hr. and 840° C. to 750° C. in 0.5 hr. Once the substrate cooled to a temperature of about 750° C., the power was turned off. The heating and cooling procedure was performed in ambient atmosphere. No apparent evaporation or melting was observed.

[0168] Once reacted, each of the 16 predefined reaction regions were screened for resistance. In doing so, it was found that two of the predefined regions contained materials which are conducting. Contacts were put on these two sites in in-line 4-probe configuration, and it was determined that the contact resistances are less than hundred ohms (i). Thereafter, the samples were cooled down to 4.2° K in a liquid helium cryostat to measure resistivity as a function of temperature. Factory calibrated Cemox™ resistance temperature sensor (LakeShore) was used to measure temperature. FIGS. 10A and 10B shows the resistance of the two conducting materials as a function of temperature. The BiPbCuSrCa material has a metallic conductivity (resistance decrease with temperature) from room temperature down to about 100° K, whereas the BiCuSrCa material has a rather flat and slightly upward temperature dependence resistance. Superconducting critical temperatures (T<sub>c</sub>) for both samples are about 100° K. Evidence of two superconducting phases in the resistivity measurement was not observed.

[0169] B. Synthesis of an Array of 16 Different Organic Polymers

[0170] This example illustrates the possible synthesis of an array of 16 different organic polymers formed by the polymerization of styrene with acrylonitrile. A 3 cm×3 cm pyrex substrate having 16 predefined regions thereon is used in this example. Each of the predefined regions is 3 mm×3 mm×5 mm and, thus, the volume of each predefined region is about 45 μL. To ensure that the reactants in a given region do not move to adjacent regions, 35 μL reaction volumes will be used.

[0171] A 2 M solution of the styrene monomer in toluene and a 2 M solution of acrylonitrile in toluene are used. The initiator used to initiate the polymerization reaction is benzoyl peroxide. A 70 mM solution of benzoyl peroxide in toluene is used. The initiator is present in each of the reactions at a 10 mM concentration. The styrene, acrylonitrile and benzoyl peroxide solutions are delivered to each of the 16 predefined regions on the substrate using an ink-jet dispenser having three nozzles. The first nozzle is connected to a reservoir containing the 2 M solution of styrene in toluene, the second nozzle is connected to a reservoir containing the 2 M solution of acrylonitrile in toluene, and the third nozzle is connected to a reservoir containing the 70 mM solution of benzoyl peroxide in toluene. The initiator is delivered to each of the 16 predefined regions only after the monomers have been delivered.

[0172] To generate an array of 16 different polymers of styrene and acrylonitrile, the reactant amounts set forth in Table II, infra, are delivered to the 16 predefined regions on the substrate. Once the monomers have been delivered to the 16 predefined regions on the substrate, 5 μL of the 70 mM initiator solution is added. The polymerization reaction is carried out at a temperature of about 60° C. and at ambient pressure. The reactions are allowed to proceed until the terminator is used up. Upon completion of the polymerization reaction, the organic solvent is removed by evaporation in vacuo (100 Torr). The resulting polymers can be screened for hardness using, for example, a nanoindenter (sharp tip).

TABLE III

VARIOUS REACTANT COMPONENTS USED TO GENERATE AN ARRAY OF 16 DIFFERENT POLYMERS		
Reaction Region	Amount of 2 M Solution of Styrene (μL)	Amount of 2 M Solution of Acrylonitrile (μL)
1	30	0
2	28.5	1.5
3	27	3
4	25.5	4.5
5	24	6
6	22.5	7.5
7	21	9
8	19.5	10.5
9	18	12
10	16.5	13.5
11	15	15
12	13.5	16.5
13	12	18
14	10.5	19.5
15	9	21
16	7.5	22.5

**[0173]** C. Synthesis of an Array of Zeolites

**[0174]** This example illustrates a possible method for the synthesis of an array of different zeolites. The reactants are delivered to a 9 cm×9 cm Teflon substrate having 16 predefined regions thereon. The substrate is placed in a sealed container having a temperature of about 100° C. Each of the 16 predefined regions on the substrate is a 1 cm×1 cm×2 cm well. The reactants are delivered to the substrate using an automated pipette.

**[0175]** The five components used to generate the array of zeolites are as follows:  $\text{Na}_2\text{O} \cdot \text{Al}_2\text{O}_3 \cdot 5\text{H}_2\text{O}$ , KOH,  $\text{Na}_2\text{O} \cdot 2\text{SiO}_2 \cdot 5\text{H}_2\text{O}$ , NaOH and  $\text{H}_2\text{O}$ . The first four components are dissolved in water to concentrations of 2.22 M, 2.22 M, 8.88 M and 11.1 M, respectively. In delivering the components to the predefined regions on the substrate, it is important that the  $\text{Na}_2\text{O} \cdot 2\text{SiO}_2 \cdot 5\text{H}_2\text{O}$  solution is added last. The five reactant components are delivered to the predefined regions on the substrate in the amounts set forth in Table III, supra.

**[0176]** Once the foregoing components have been delivered to the appropriate predefined regions on the substrate and allowed to react, the array can be scanned for microstructure using a Raman Light Scattering System. Scanning of the array can begin 2 to 3 hours after the components have been delivered to the substrate and can continue for anywhere from 5 to 10 days. In this example, Zeolite A will initially be formed at reaction region 1. With time, however, Zeolite A will be converted to Zeolite P. Zeolite X will be formed at reaction region 3. Sodalite will be formed at reaction region 6. Zeolite L will be formed at reaction region 12. In addition, other zeolites may be formed at other reaction regions on the substrate.

TABLE IV.

VARIOUS REACTANT COMPONENTS USED TO GENERATE AN ARRAY OF ZEOLITES					
Reaction Region	Amount of 2.2 M Solution of $\text{Na}_2\text{O} \cdot \text{Al}_2\text{O}_3 \cdot 5\text{H}_2\text{O}$ ( $\mu\text{L}$ )	Amount of 8.88 M Solution of KOH ( $\mu\text{L}$ )	Amount of 2.2 M Solution of $\text{Na}_2\text{O} \cdot 2\text{SiO}_2 \cdot 5\text{H}_2\text{O}$ ( $\mu\text{L}$ )	Amounts of 11.1 M Solution of NaOH ( $\mu\text{L}$ )	Amount of $\text{H}_2\text{O}$ ( $\mu\text{L}$ )
	1	100	0	100	
2	100	0	100	80	1280
3	100	0	200	40	420
4	100	0	200	40	1220
5	100	0	100	320	240
6	100	0	100	320	1040
7	100	0	200	280	180
8	100	0	200	280	980
9	100	200	100	80	280
10	100	200	100	80	1080
11	100	200	200	40	220
12	100	200	200	40	1020
13	100	200	100	320	40
14	100	200	100	320	840
15	100	200	200	280	0
16	100	200	200	280	800

**[0177]** D. Synthesis of an Array of Copper Oxide Compounds Using Spraying Deposition Techniques

**[0178]** This example illustrates the synthesis of an array of different copper oxide compounds using spraying deposition

techniques. The reactants are delivered to a 1.25 cm×1.25 cm MgO substrate having 16 predefined regions thereon. The reactants are delivered in the form of thin-films using a sprayer in combination with physical masking techniques. The sprayer used in this example is a Sinitek 8700-120MS ultrasonic sprayer. At a water flow rate of 0.26 GPM and a frequency of 120 KHz, this sprayer can generate a cone-line spraying pattern of 2 inches and a droplet diameter of 18 microns.

**[0179]** The four components used in this example to generate the array of inorganic materials are  $\text{Bi}(\text{NO}_3)_3$ ,  $\text{Cu}(\text{NO}_3)_3$ ,  $\text{Ca}(\text{NO}_3)_3$  and  $\text{Si}(\text{NO}_3)_3$ . These components were dissolved in water to concentrations of 0.8 M, 2 M, 2 M and 2 M, respectively. The pH of the  $\text{Bi}(\text{NO}_3)_3$  solution was about 0.9. In delivering the reactants to the predefined regions on the substrate, it is important to control the flow rate of the sprayer as well as the temperature of the substrate so that the reactant droplets dry immediately upon contact with the substrate surface. The flow rate used was kept at about 0.26 GPM, and the temperature of the substrate was maintained at about 2100 C. In addition, it is important to control the spraying time so that the amount, i.e., moles, of each reactant is approximately the same. The spraying time was such that each of the thin-layer films deposited on the surface of the substrate had a thickness of about 1 to 4 microns.

**[0180]** Using a binary masking strategy, the aqueous solutions of  $\text{Ca}(\text{NO}_3)_3$ ,  $\text{Bi}(\text{NO}_3)_3$ ,  $\text{Cu}(\text{NO}_3)_3$  and  $\text{Si}(\text{NO}_3)_3$  were delivered, in this order, to the substrate using the following steps. As mentioned, the MgO substrate had 16 predefined regions 1, 2, 3, 4, 5, 6, 7, 8, 9, 10, 11, 12, 13, 14, 15 and 16. In a first masking step, regions 9, 10, 11, 12, 13, 14, 15, and 16 were masked and an aqueous solution of  $\text{Ca}(\text{NO}_3)_3$  was delivered to the exposed regions in the form of a thin-film. Thereafter, in a second masking step, the mask was repositioned so that regions 3, 4, 7, 8, 11, 12, 15 and 16 were masked, and an aqueous solution of  $\text{Bi}(\text{NO}_3)_3$  was delivered to the exposed regions in the form of a thin-film. In a third masking step, regions 5, 6, 7, 8, 13, 14, 15 and 16 were masked, and an aqueous solution of  $\text{Cu}(\text{NO}_3)_3$  was delivered to the exposed regions in the form of a thin-film. Finally, in a fourth masking step, regions 2, 4, 6, 8, 10, 12, 14 and 16 were masked, and an aqueous solution of  $\text{Si}(\text{NO}_3)_3$  was delivered to the exposed regions in the form of a thin-film.

**[0181]** Once the components of interest were delivered to the appropriate predefined regions on the substrate, the substrate having the array of reactants thereon was oxidized at 300° C. to remove any nitrogen from the array. Thereafter, the substrate was flash heated at 880° C. for about 2 minutes and rapidly quenched on a copper block. Thereafter, the array of materials was screened for superconducting material.

**[0182]** E. Synthesis of an Array of Manganese Oxide Thin-film Materials

**[0183]** This example illustrates the possible synthesis and screening of an array of manganese oxide thin-film materials. The reactants are delivered to a 1.25 cm×1.25 cm  $\text{LaAlO}_3$  substrate with a (100) polished surface. The substrate having 16 predefined regions thereon is contained in a reaction chamber in vacuo. The reactants are delivered to the substrate in the form of thin-films using a sputtering system in combination with binary masking techniques. The



binary mask is made of stainless steel. A RF magnetron gun sputtering system is used to deliver the reactant components to the predefined regions on the substrate. The RF magnetron sputtering gun (Mini-mak manufactured by US, Inc., Campbell, Calif.) used is about 1.3 inches in diameter. With RF input power (supplied by a Plasmtherm-2000 with a matching network) of 50 to about 200 W, deposition rates ranged from about 0.3 Å/s to about 2 Å/s for the five different reactant components. The RF magnetron sprayer is positioned about 3 to 4 inches above the substrate and the uniformity of deposited film is about 5% over a 1 to 2 inch diameter area. The sputtering gas flow (Ar or Ar and O<sub>2</sub>) is controlled by metering valves and differential pumping through a manual gate valve. To achieve a high deposition rate, it is determined that the best pressure range is about 5 to 15 mTorr. The partial pressure of each gas component in the chamber is monitored using a residual gas analyzer (Micropole Sensor by Ferran Scientific, San Diego, Calif.) directly up to 15 mTorr without differential pumping.

[0184] The reactant components used to generate the array of copper oxide materials are as follows: MnO<sub>2</sub>, La<sub>2</sub>O<sub>3</sub>, CaO, SrF<sub>2</sub>, and BaF<sub>2</sub>. MnO<sub>2</sub> is used as the base element in an effort to discover new manganese oxide materials and, thus, this component is delivered to each of the 16 predefined regions on the substrate. Prior to delivering the component of interest to the predefined regions on the substrate, the base air pressure of the reaction chamber is lowered, within 10 to 15 minutes, to about 10<sup>-5</sup> to 10<sup>-4</sup> Torr by a 250 l/s turbo pump and, thereafter, it is furthered lowered to 10<sup>-8</sup> Torr using extended pumping time in combination with heating the reaction chamber to about 100° C. to about 150° C. Since only a single RF magnetron gun sputtering system is employed, the vacuum is broken and reestablished each time the component is changed. The film deposition thickness is monitored using a crystal microbalance (STM-100 by Sycon Instruments, Syracuse, N.Y.).

[0185] The reactant components are delivered to the LaAlO<sub>3</sub> substrate in the following order: MnO<sub>2</sub>, La<sub>2</sub>O<sub>3</sub>, CaO, SrF<sub>2</sub>, and BaF<sub>2</sub>. The stoichiometry is designed so that each of the five components is present in equal molar amounts, i.e., 2 M:1 La:1 Ca:1 Sr:1 Ba as deposited film. The total thickness of the film is about 0.4 μm for a five layered site. The thickness of each of the individual films as well as the sputtering rates at which each of the components are deposited are set forth in Table V, supra.

TABLE V

DEPOSITION THICKNESS AND SPUTTERING RATE FOR THE COMPONENTS USED TO GENERATE AN ARRAY OF MANGANESE OXIDES		
Component	Deposition Thickness	Sputtering Rate
La <sub>2</sub> O <sub>3</sub>	480 Å	0.3 Å/SEC
MnO <sub>2</sub>	1000 Å	1 Å/SEC
BaF <sub>2</sub>	1040 Å	0.3 Å/SEC
SrF <sub>2</sub>	860 Å	0.3 Å/SEC
CaO	480 Å	0.3 Å/SEC

[0186] Once the components of interest are delivered to the 16 predefined regions on the substrate, the substrate is placed in a furnace, and the components are subsequently reacted. The components are simultaneously reacted using the following heating and cooling procedure: 50° C. to 840°

C. in 2 hr., 840° C. to 900° C. in 0.5 hr. and 900° C. to 840° C. in 0.5 hr. Once the substrate cools to a temperature of about 840° C., the power is turned off. The heating and cooling procedure is performed in ambient atmosphere. No apparent evaporation or melting is observed.

[0187] Once reacted, each of the 16 predefined reaction regions are screened for giant magnetoresistant (GMR) materials using a 12 Telsa superconducting magnet cryostat (manufactured by Janis Research Co., Inc., Willmington, Mass.) using contact measurement techniques. Non-contact measurement techniques using similar scanning detection systems for high T<sub>c</sub> materials can also be applied to increase the efficiency and resolution.

[0188] F. Synthesis of an Array of 16 Different Zinc Silicate Phosphors

[0189] This example illustrates the possible synthesis of an array of 16 different zinc silicate phosphors. A 1 mm×1 mm pyrex substrate having 16 predefined regions thereon is used in this example. Each of the predefined regions is 100 μm×100 μm×500 μm and, thus, the volume of each predefined region is about 5,000 picoliters. To ensure the reactants in a given region do not move to adjacent regions, 3,000 picoliter reaction volumes will be used.

[0190] The reactants will be delivered simultaneously to each region on the substrate using an ink-jet dispenser having three nozzles. The first nozzle is connected to a reservoir containing a 1M solution of ZnO in water. To generate an array of 16 different phosphors, the reactant amounts set forth in Table VI, infra, are delivered to the 16 predefined regions on the substrate. The synthesis reaction is carried out under a nitrogen atmosphere for a period of 2 hrs. at 1400° C. Once formed, each of the 16 predefined reaction regions is screened for electroluminescent materials or phosphors by radiating the sample with a specific excitation wavelength and recording the emission spectra with a Perkin-Elmer LS50 spectrofluorimeter.

TABLE VI

VARIOUS REACTANT COMPONENTS USED TO GENERATE AN ARRAY OF ZINC SILICATE PHOSPHORS			
Reaction Region	SiCO <sub>2</sub>	MnCO <sub>3</sub> (picoliters)	ZnO
1	1500	1425	75
2	1500	1350	150
3	1500	1275	225
4	1500	1200	300
5	1500	1125	375
6	1500	1050	450
7	1500	975	525
8	1500	900	600
9	2000	950	50
10	2000	900	100
11	2000	850	150
12	2000	800	200
13	2000	750	250
14	2000	700	300
15	2000	650	350
16	2000	600	400

## X. CONCLUSION

[0191] The present invention provides greatly improved methods and apparatus for the parallel deposition, synthesis

and screening of an array of materials on a single substrate. It is to be understood that the above description is intended to be illustrative and not restrictive. Many embodiments and variations of the invention will become apparent to those of skill in the art upon review of this disclosure. Merely by way of example a wide variety of process times, reaction temperatures and other reaction conditions may be utilized, as well as a different ordering of certain processing steps. The scope of the invention should, therefore, be determined not with reference to the above description, but instead should be determined with reference to the appended claims along with the full scope of equivalents to which such claims are entitled.

What is claim is:

1. A method of making an array of materials, said method comprising:

- (a) delivering a first component of a first material and a first component of a second material to first and second regions on a substrate;
- (b) delivering a second component of said first material and a second component of said second material to said first and second regions on said substrate; and
- (c) simultaneously reacting said components to form at least two materials.

2. The method as recited in claim 1 wherein said materials are covalent network solids.

3. The method as recited in claim 1 wherein said materials are ionic solids.

4. The method as recited in claim 1 wherein said materials are molecular solids.

5. The method as recited in claim 1 wherein said materials are inorganic materials.

6. The method as recited in claim 5 wherein said inorganic materials are intermetallic materials.

7. The method as recited in claim 5 wherein said inorganic materials are metal alloys.

8. The method as recited in claim 5 wherein said inorganic materials are ceramic materials.

9. The method as recited in claim 1 wherein said materials are organometallic materials.

10. The method as recited in claim 1 wherein said materials are composite materials.

11. The method as recited in claim 1 wherein said materials are non-biological organic polymers.

12. The method as recited in claim 1 wherein said first component of said first material and said second component of said first material are simultaneously delivered to said first region.

13. The method as recited in claim 1 wherein said first component of said first material and said first component of said second material are simultaneously delivered to said first region and said second region, respectively.

14. The method as recited in claim 1 wherein said first component of said first material and said first component of said second material are the same, but are offered in different concentrations.

15. The method as recited in claim 1 wherein said second component of said first material and said second component of said second material are the same, but are offered in different concentrations.

16. The method as recited in claim 1 wherein said first component of said first material is delivered to said first region in a gradient of stoichiometries.

17. The method as recited in claim 1 wherein said first component of said first material and said first component of said second material are the same, but are offered to said first and second regions on said substrate in a gradient of stoichiometries.

18. The method as recited in claim 1 wherein the components of said materials are delivered to said first and second regions on said substrate from a pipette.

19. The method as recited in claim 1 wherein the components of said materials are delivered to said first and second regions on said substrate from a pulse pressure ink-jet dispenser.

20. The method as recited in claim 1 wherein the components of said materials are delivered to said first and second regions on said substrate from bubble jet ink-jet dispenser.

21. The method as recited in claim 1 wherein the components of said materials are delivered to said first and second regions on said substrate from a slit jet ink-jet dispenser.

22. The method as recited in claim 1 wherein said steps of delivering said components each comprises the following steps:

- (i) identifying a reference point on said substrate;
- (ii) moving a dispenser of said component a fixed distance and direction from said reference point such that said dispenser is positioned approximately above said first region on said substrate;
- (iii) delivering said component to said first region; and
- (iv) repeating steps (ii) and (iii) for each remaining component for each remaining region.

23. The method as recited in claim 1 wherein said step of delivering said first component of said first material to said first region on said substrate comprises the steps of:

- (i) placing a mask adjacent to said substrate, said mask permitting said first component of said first material to be delivered to said first region on said substrate, but not to said second region on said substrate;
- (ii) delivering said first component of said first material to said first region on said substrate; and
- (iii) removing said mask.

24. The method as recited in claim 1 wherein said step of delivering said first component of said first material to said first region on said substrate comprises the steps of:

- (i) placing a mask adjacent to said substrate, said mask permitting said first component of said first material to be delivered to said first region on said substrate, but not to said second region on said substrate;
- (ii) depositing a thin-film of said first component of said first material on said first region on said substrate; and
- (iii) removing said mask.

25. The method as recited in claim 1 wherein said step of delivering said first component of said first material to said first region on said substrate comprises the steps of:

- (i) placing a mask adjacent to said substrate, said mask permitting said first component of said first material to

be delivered to said first region on said substrate, but not to said second region on said substrate;

- (ii) spraying said first component of said first material onto said first region on said substrate; and
- (iii) removing said mask.

26. The method as recited in claim 1 wherein said step of delivering said first component of said first material to said first region on said substrate comprises the steps of:

- (i) depositing a photoresist on said substrate;
- (ii) selectively exposing said photoresist on said substrate;
- (iii) selectively removing said photoresist from said substrate to expose said first region;
- (iv) delivering said first component of said first material to said first region on said substrate; and
- (v) removing remaining photoresist from said substrate.

27. The method as recited in claim 1 wherein said step of delivering said first component of said first material to said first region on said substrate comprises the steps of:

- (i) delivering said first component of said first material to first and second regions on said substrate;
- (ii) depositing a photoresist on said substrate;
- (iii) selectively exposing said photoresist on said substrate;
- (iv) selectively removing said photoresist from said second region on said substrate, thereby exposing said first component of said first material;
- (v) etching off the exposed first component of said first material; and
- (vi) removing remaining photoresist from said substrate.

28. The method as recited in claim 1 wherein each of said materials is synthesized in an area of less than 25 cm<sup>2</sup>.

29. The method as recited in claim 1 wherein each of said materials is synthesized in an area of less than 10 cm<sup>2</sup>.

30. The method as recited in claim 1 wherein each of said materials is synthesized in an area of less than 5 cm<sup>2</sup>.

31. The method as recited in claim 1 wherein each of said materials is synthesized in an area of less than 1 cm<sup>2</sup>.

32. The method as recited in claim 1 wherein each of said materials is synthesized in an area of less than 1 mm<sup>2</sup>.

33. The method as recited in claim 1 wherein each of said materials is synthesized in an area of less than 10,000 μm<sup>2</sup>.

34. The method as recited in claim 1 wherein each of said materials is synthesized in an area of less than 1,000 μm<sup>2</sup>.

35. The method as recited in claim 1 wherein each of said materials is synthesized in an area of less than 100 μm<sup>2</sup>.

36. The method as recited in claim 1 wherein each of said materials is synthesized in an area of less than 1 μm<sup>2</sup>.

37. The method as recited in claim 1 wherein at least 10 different materials are synthesized on said substrate.

38. The method as recited in claim 1 wherein at least 100 different materials are synthesized on said substrate.

39. The method as recited in claim 1 wherein at least 100 different materials are synthesized on said substrate.

40. The method as recited in claim 1 wherein at least 10<sup>6</sup> different materials are synthesized on said substrate.

41. The method as recited in claim 1 wherein at least 100 different materials are synthesized, and each different material is contained within an area of about 1 mm<sup>2</sup> or less.

42. The method as recited in claim 1 further comprising the step of screening said array of materials for a useful property.

43. The method as recited in claim 42 wherein said useful property is an electrical property.

44. The method as recited in claim 42 wherein said useful property is a thermal property.

45. The method as recited in claim 42 wherein said useful property is a mechanical property.

46. The method as recited in claim 42 wherein said useful property is a morphological property.

47. The method as recited in claim 42 wherein said useful property is an optical property.

48. The method as recited in claim 42 wherein said useful property is a magnetic property.

49. The method as recited in claim 42 wherein said useful property is a chemical property.

50. The method as recited in claim 42 wherein said array of materials is screened in parallel.

51. The method as recited in claim 42 wherein said array of materials is screened sequentially.

52. An array of more than 10 different inorganic materials on a substrate at known locations thereon.

53. The array as recited in claim 52 wherein more than 100 different inorganic materials on a substrate at known locations thereon.

54. The array as recited in claim 52 wherein more than 10<sup>3</sup> different inorganic materials on a substrate at known locations thereon.

55. The array as recited in claim 52 wherein more than 10<sup>6</sup> different inorganic materials on a substrate at known locations thereon.

56. The array as recited in claim 52 wherein said inorganic materials are intermetallic materials.

57. The array as recited in claim 52 wherein said inorganic materials are metal alloys.

58. The array as recited in claim 52 wherein said inorganic materials are ceramic materials.

59. The array as recited in claim 52 wherein said inorganic materials are inorganic-organic composite materials.

60. A method of making at least two different arrays of materials, said method comprising:

- (a) delivering a first component of a first material to a first region on a first substrate and delivering said first component of said first material to a first region on a second substrate;
- (b) delivering a first component of a second material to a second region on said first substrate and delivering said first component of said second material to a second region on said second substrate;
- (c) delivering a second component of said first material to said first region on said first substrate and delivering said second component of said first material to said first region on said second substrate;
- (d) delivering a second component of said second material to said second region on said first substrate and delivering said second component of said second material to said second region on said second substrate; and
- (e) reacting said components on said first substrate under a first set of reaction conditions and said components

on said second substrate under a second set of reaction conditions to form at least two different arrays of at least two materials.

61. The method as recited in claim 60 wherein said materials are covalent network solids.

62. The method as recited in claim 60 wherein said materials are ionic solids

63. The method as recited in claim 60 wherein said materials are molecular solids.

64. The method as recited in claim 60 wherein said materials are inorganic materials.

65. The method as recited in claim 64 wherein said materials are intermetallic materials.

66. The method as recited in claim 64 wherein said inorganic materials are metal alloys.

67. The method as recited in claim 64 wherein said inorganic materials are ceramic materials.

68. The method as recited in claim 60 wherein said materials are organometallic materials.

69. The method as recited in claim 60 wherein said materials are composite materials.

70. The method as recited in claim 60 wherein said materials are non-biological organic polymers.

71. The method as recited in claim 60 wherein said first set of reaction conditions differs from said second set of reaction conditions in terms of the temperature at which the reactions are carried out.

72. The method as recited in claim 60 wherein said first set of reaction conditions differs from said second set of reaction conditions in terms of the pressure at which the reactions are carried out.

73. The method as recited in claim 60 wherein said first set of reaction conditions differs from said second set of reaction conditions in terms of the reaction times at which the reactions are carried out.

74. The method as recited in claim 60 wherein said first set of reaction conditions differs from said second set of reaction conditions in terms of the atmosphere in which the reactions are carried out.

75. The method as recited in claim 60 wherein said first component of said first material and said first component of said second material are the same, but are offered in different concentrations.

76. A material having a useful property prepared by a process comprising the steps of:

(a) forming an array of different materials on a single substrate;

(b) screening said array for a material having said useful property; and

(c) making additional amounts of said material having said useful property.

77. The material as recited in claim 76 wherein step (a) of said process further comprises the steps of:

(i) delivering a first component of a first material and a first component of a second material to first and second regions on a substrate;

(ii) delivering a second component of said first material and a second component of said second material to first and second regions on said substrate; and

(iii) simultaneously reacting said components to form said array of at least two different materials.

78. The material as recited in claim 77 wherein said first component of said first material and said first component of said second material are the same, but are offered in different concentrations.

79. The material as recited in claim 76 wherein said material is a covalent network solid.

80. The material as recited in claim 76 wherein said material is an ionic solids.

81. The material as recited in claim 76 wherein said material is a molecular solid.

82. The material as recited in claim 76 wherein said material is an inorganic material.

83. The method as recited in claim 82 wherein said inorganic material is an intermetallic material.

84. The method as recited in claim 82 wherein said inorganic material is a metal alloy.

85. The method as recited in claim 82 wherein said inorganic material is a ceramic material.

86. The method as recited in claim 76 wherein said material is an organometallic material.

87. The method as recited in claim 76 wherein said material is a composite material.

88. The method as recited in claim 76 wherein said material is a non-biological organic polymer.

89. The method as recited in claim 76 wherein said material is a high temperature superconductor.

90. The method as recited in claim 76 wherein said material is a magnetoresistive material.

91. The method as recited in claim 76 wherein said material is a zeolite.

92. The method as recited in claim 76 wherein said material is a phosphor.

93. The method as recited in claim 76 wherein said material is a conducting polymer.

\* \* \* \* \*