

(19) World Intellectual Property Organization  
International Bureau



(43) International Publication Date  
30 November 2006 (30.11.2006)

PCT

(10) International Publication Number  
**WO 2006/127898 A2**

(51) International Patent Classification:

*C07D 489/08* (2006.01) *A61P 1/12* (2006.01)  
*A61K 31/485* (2006.01) *A61P 25/04* (2006.01)

(74) Agent: VAN AMSTERDAM, John, R.; WOLF, GREENFIELD & SACKS, P.C., 600 Atlantic Avenue, Boston, MA 02210 (US).

(21) International Application Number:

PCT/US2006/020232

(81) Designated States (unless otherwise indicated, for every kind of national protection available): AE, AG, AL, AM, AT, AU, AZ, BA, BB, BG, BR, BW, BY, BZ, CA, CH, CN, CO, CR, CU, CZ, DE, DK, DM, DZ, EC, EE, EG, ES, FI, GB, GD, GE, GH, GM, HR, HU, ID, IL, IN, IS, JP, KE, KG, KM, KN, KP, KR, KZ, LC, LK, LR, LS, LT, LU, LV, LY, MA, MD, MG, MK, MN, MW, MX, MZ, NA, NG, NI, NO, NZ, OM, PG, PH, PL, PT, RO, RU, SC, SD, SE, SG, SK, SL, SM, SY, TJ, TM, TN, TR, TT, TZ, UA, UG, US, UZ, VC, VN, YU, ZA, ZM, ZW.

(22) International Filing Date: 25 May 2006 (25.05.2006)

(25) Filing Language: English

(26) Publication Language: English

(30) Priority Data:

60/684,570 25 May 2005 (25.05.2005) US

(84) Designated States (unless otherwise indicated, for every kind of regional protection available): ARIPO (BW, GH, GM, KE, LS, MW, MZ, NA, SD, SL, SZ, TZ, UG, ZM, ZW), Eurasian (AM, AZ, BY, KG, KZ, MD, RU, TJ, TM), European (AT, BE, BG, CH, CY, CZ, DE, DK, EE, ES, FI, FR, GB, GR, HU, IE, IS, IT, LT, LU, LV, MC, NL, PL, PT, RO, SE, SI, SK, TR), OAPI (BF, BJ, CF, CG, CI, CM, GA, GN, GQ, GW, ML, MR, NE, SN, TD, TG).

(71) Applicant (for all designated States except US): PROGENICS PHARMACEUTICALS, INC. [US/US]; 777 Old Saw Mill River Road, Tarrytown, NY 10591 (US).

(72) Inventors; and

(75) Inventors/Applicants (for US only): WAGONER, Howard [US/US]; 334 Cascade Road, Warwick, NY 10990 (US). SANGHVI, Suketu, P. [US/US]; 1 Hancock Drive, Kendall Park, NJ 18824 (US). BOYD, Thomas, A. [US/US]; 279 River Road, Grandview, NY 10960 (US). VERBICKY, Christopher [US/US]; 992 Ridge River Road, Broadalbin, NY 12025 (US). ANDRUSKI, Stephen [US/US]; 7 Sylvan Lane, Clifton Park, NY 12065 (US).

Published:

— without international search report and to be republished upon receipt of that report

For two-letter codes and other abbreviations, refer to the "Guidance Notes on Codes and Abbreviations" appearing at the beginning of each regular issue of the PCT Gazette.

(54) Title: (S)-N-METHYLNALTREXONE

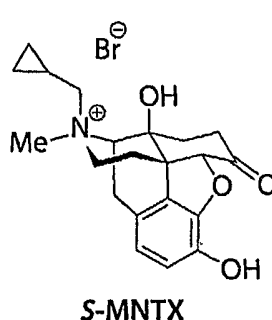
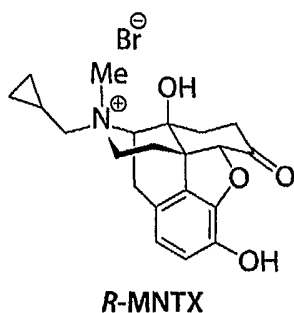

(57) Abstract: This invention relates to S-MNTX, methods of producing S-MNTX, pharmaceutical preparations comprising S-MNTX and methods for their use.

WO 2006/127898 A2

- 1 -

**(S)-N-METHYLNALTREXONE****FIELD OF THE INVENTION**

This invention relates to (*S*)-*N*-methylnaltrexone (S-MNTX), stereoselective  
5 synthetic methods for the preparation of S-MNTX, pharmaceutical preparations  
comprising S-MNTX and methods for their use.

**BACKGROUND OF INVENTION**

Methylnaltrexone (MNTX) is a quaternary derivative of the pure opioid  
10 antagonist, naltrexone. It exists as a salt. Names used for the bromide salt of MNTX in  
the literature include: Methylnaltrexone bromide; *N*-Methylnaltrexone bromide;  
Naltrexone methobromide; Naltrexone methyl bromide; MRZ 2663BR. MNTX was first  
reported in the mid-70s by Goldberg et al as described in US Patent No. 4,176,186. It is  
believed that addition of the methyl group to the ring nitrogen forms a charged  
15 compound with greater polarity and less liposolubility than naltrexone. This feature of  
MNTX prevents it from crossing the blood-brain barrier in humans. As a consequence,  
MNTX exerts its effects in the periphery rather than in the central nervous system with  
the advantage that it does not counteract the analgesic effects of opioids on the central  
nervous system.

20 MNTX is a chiral molecule and the quaternary nitrogen can be in R or S  
configuration. (See FIG. 1.) It is unknown whether the different stereoisomers of MNTX  
exhibit different biological and chemical properties. All of the reported functions of  
MNTX described in the literature indicate that MNTX is a peripheral opioid antagonist.  
Some of these antagonist functions are described in U.S. Patents 4,176,186, 4,719,215,  
25 4,861,781, 5,102,887, 5,972,954, 6,274,591, 6,559,158, and 6,608,075, and in U.S.  
Patent Application Serial Nos. 10/163,482 (2003/0022909A1), 10/821,811  
(20040266806), 10/821,813 (20040259899) and 10/821,809 (20050004155). These uses  
include reducing the side-effects of opioids without reducing the analgesic effect of  
opioids. Such side-effects include nausea, emesis, dysphoria, pruritus, urinary retention,  
30 bowel hypomotility, constipation, gastric hypomotility, delayed gastric emptying and  
immune suppression. The art discloses that MNTX not only reduces the side-effects  
stemming from opioid analgesic treatment but also reduces the side-effects mediated by  
endogenous opioids alone or in conjunction with exogenous opioid treatment. Such side-

- 2 -

effects include inhibition of gastrointestinal motility, post-operative gastrointestinal dysfunction, idiopathic constipation and other such conditions including, but not limited to, those mentioned above. However, it is unclear from the art whether the MNTX used in these studies was a mixture of R and S stereoisomers or a single stereoisomer.

5           The art suggests that isolated stereoisomers of a compound sometimes may have contrasting physical and functional properties, although it is unpredictable whether this is the case in any particular circumstance. Dextromethorphan is a cough suppressant, whereas its enantiomer, levomethorphan, is a potent narcotic. R,R-methylphenidate is a drug to treat attention deficit hyperactivity disorder (ADHD), whereas its enantiomer,  
10       S,S-methylphenidate is an antidepressant. S-fluoxetine is active against migraine, whereas its enantiomer, R-fluoxetine is used to treat depression. The S enantiomer of citalopram is therapeutically active isomer for treatment of depression. The R enantiomer is inactive. The S enantiomer of omeprazole is more potent for the treatment of heartburn than the R enantiomer.

15           Bianchetti et al, 1983 *Life Science* 33 (Sup D):415-418 studied three pairs of diastereoisomers of quaternary narcotic antagonist and their parent tertiary amines, levallorphan, nalorphine, and naloxone, to see how the configuration about the chiral nitrogen affected in vitro and in vivo activity. It was found that the activity varied considerably depending on how the quaternary derivatives were prepared. In each series,  
20       only the diastereomer obtained by methylation of the N-allyl-substituted tertiary amine (referred to as "N-methyl diastereomer") was potent in displacing <sup>3</sup>H-naltrexone from rat brain membranes, and acting as a morphine antagonist in the guinea-pig ileum. Conversely, diastereoisomers obtained by reacting N-methyl-substituted tertiary amines with allyl halide (referred to as "N-allyl diastereomers") did not displace <sup>3</sup>H-naltrexone  
25       and had negligible antagonist activity and slight agonist action in the guinea-pig ileum. In vivo findings were generally consistent with those in vitro. Thus only the "N-methyl" but not the "N-allyl diastereomers" inhibited morphine-induced constipation in rats and behaved as antagonists. The author stated that the prepared materials appeared to be pure by <sup>1</sup>H and <sup>13</sup>C nuclear magnetic resonance (NMR) analysis, but these methods are  
30       not accurate. The author cites a literature reference for the assignment of the R configuration to the "N-methyl diastereomer" of nalorphine. No assignment is proposed for the levallorphan and naloxone diastereomers. It would be adventurous to extrapolate

- 3 -

the configuration to these diastereomers (R.J. Kobylecki et al, J. Med. Chem. 25, 1278-1280, 1982).

Goldberg et al.'s US Patent No. 4,176,186, and more recently Cantrell et al.'s WO 2004/043964 A2 describe a protocol for the synthesis of MNTX. Both describe a synthesis of MNTX by quaternizing a tertiary N-substituted morphinan alkaloid with a methylating agent. Both Goldberg et al. and Cantrell et al. are silent as to the stereoisomer(s) produced by the synthesis. The authors remained cautiously silent about the stereochemistry because the stereochemistry could not be determined based on prior art. The cyclopropylmethyl side-chain in naltrexone is different from the prior art side-chains and may have affected the stereochemical outcome in the synthesis of MNTX, as may other reaction parameters such as temperature and pressure. Based on the method of synthesis described in each, it is unknown whether the MNTX so produced was R, S or a mixture of both.

S-MNTX in pure form, and a method of making pure S-MNTX have not been described in the literature. Researchers would have been unable to definitively characterize and distinguish the stereoisomer(s) obtained by the Goldberg et al. or Cantrell et al. synthesis in the absence of S-MNTX as a standard.

### SUMMARY OF THE INVENTION

S-MNTX has now been produced in high purity, permitting the characterization of its relative retention time in chromatography versus that of (*R*)-*N*-methylnaltrexone (R-MNTX). S-MNTX has been found to have activity different from the activity of MNTX reported in the literature.

The present invention provides highly pure S-MNTX, crystals of highly pure S-MNTX and intermediates thereof, novel methods for making highly pure S-MNTX, methods for analyzing S-MNTX in a mixture of R-MNTX and S-MNTX, methods of distinguishing R-MNTX from S-MNTX, methods of quantifying S-MNTX, pharmaceutical products containing the same and related uses of these materials.

S-MNTX, and salts thereof are provided. A protocol for obtaining S-MNTX was unpredictable from the prior art. In addition, it has been discovered, surprisingly, that S-MNTX has opioid agonist activity.

- 4 -

According to one aspect of the invention, a composition is provided. The composition is an isolated compound of the S configuration with respect to nitrogen of Formula I:

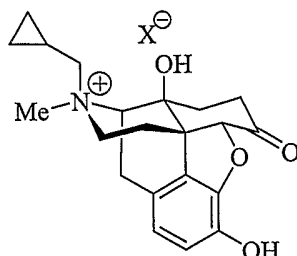

Formula I (S-MNTX)

5 wherein X is a counterion.

S-MNTX is a salt. Therefore, there will be a counterion, which for the present application, includes the zwitterion. More typically, the counterion is a halide, sulfate, phosphate, nitrate, or anionic-charged organic species. Halides include fluoride, chloride, iodide and bromide. In some important embodiments, the halide is iodide and  
 10 in other important embodiments the halide is bromide. In some embodiments the anionic-charged species is a sulfonate or a carboxylate. Examples of sulfonates include mesylate, besylate, tosylate, and triflate. Examples of carboxylates include formate, acetate, citrate, and fumarate.

According to the invention, S-MNTX is provided in isolated form. By isolated, it  
 15 is meant at least 50% pure. In important embodiments, S-MNTX is provided at 75% purity, at 90% purity, at 95% purity, at 98% purity, and even at 99% purity or above. In one important embodiment, the S-MNTX is in a crystal form.

According to another aspect of the invention, a composition is provided. The composition is MNTX, wherein the MNTX present in the composition is greater than  
 20 10% in S configuration with respect to nitrogen. More preferably, the MNTX present in the composition is greater than 30%, 40%, 50%, 60%, 70%, 75%, 80%, 85%, 90%, 95%, 96%, 97%, 98%, 98.5%, 99%, 99.5%, 99.6%, 99.7%, 99.8%, and even 99.9% in S configuration with respect to nitrogen. In some embodiments there is no detectable R-MNTX as measured by high performance liquid chromatography (HPLC).

25 The composition in some embodiments is a solution, in others an oil, in others a cream, and in still others a solid or semi-solid. In one important embodiment, the composition is a crystal.

- 5 -

According to another aspect of the invention, a pharmaceutical preparation is provided. The pharmaceutical preparation includes any one of the compositions of S-MNTX described above in a pharmaceutically acceptable carrier. The pharmaceutical preparation contains an effective amount of S-MNTX. In some embodiments, there is little or no detectable R-MNTX in the composition. If present, R-MNTX is at a level such that effective amounts of S-MNTX are administered to a subject. In some embodiments, the pharmaceutical preparation further includes a therapeutic agent other than MNTX. In one embodiment, the therapeutic agent is an opioid or opioid agonist. Examples of opioids or opioid agonists are alfentanil, anileridine, asimadoline,bremazocine, burprenorphine, butorphanol, codeine, dezocine, diacetylmorphine (heroin), dihydrocodeine, diphenoxylate, fedotozine, fentanyl, funaltrexamine, hydrocodone, hydromorphone, levallorphan, levomethadyl acetate, levorphanol, loperamide, meperidine (pethidine), methadone, morphine, morphine-6-glucuronide, nalbuphine, nalorphine, opium, oxycodone, oxymorphone, pentazocine, propiram, propoxyphene, remifentanyl, sufentanil, tilidine, trimebutine, tramadol, or combinations thereof. In some embodiments, the opioid or opioid agonist does not readily cross the blood brain barrier and, therefore, has substantially no central nervous system (CNS) activity when administered systemically (i.e., it is of the class of agents known as “peripherally acting”) agents. In other embodiments the therapeutic agent is an opioid antagonist. Opioid antagonists include peripheral mu opioid antagonists. Examples of peripheral mu opioid antagonists include quarternary derivatives of noroxymorphone (See Goldberg et al, US Patent No. 4,176,186, and Cantrell et al WO 2004/043964), piperidine N-alkylcarboxylates such as described in U.S. patents 5,250,542; 5,434,171; 5,159,081; 5,270,328; and 6,469,030, opium alkaloid derivatives such as described in U.S. patents 4,730,048; 4,806,556; and 6,469,030, quaternary benzomorphan compounds such as described in U.S. patents 3,723,440 and 6,469,030.

In one embodiment, the peripheral opioid antagonist is R-MNTX. R-MNTX is the predominant form of MNTX following the manufacturing procedures described in the prior art, although it is believed that such preparations are contaminated with S-MNTX. Pure R-MNTX can be synthesized using the following protocol. In brief, stereoselective synthesis of R-MNTX is carried out by adding a hydroxyl protecting group to naltrexone to yield 3-O-protected-naltrexone; methylating the 3-O-protected-naltrexone to yield 3-O-protected-R-MNTX salt; and removing hydroxyl protecting

- 6 -

group to yield R-MNTX. The hydroxyl protecting group can be added in the presence of each or both: an organic solvent, e.g. tetrahydrofuran, and/or a tertiary amine that is not naltrexone, e.g. triethylamine. The naltrexone can be methylated by reacting the 3-*O*-protected-naltrexone with methyl iodide to produce 3-*O*-protected-R-MNTX iodide salt. Naltrexone can be protected by a hydroxyl protecting group such as isobutyryl. The 3-*O*-protected-R-MNTX iodide salt can be treated with hydrobromic acid to remove the protecting group and produce R-MNTX bromide/iodide salt, and the bromide/iodide salt can be passed through an anion exchange resin column (bromide form) to yield R-MNTX bromide.

In other embodiments, the therapeutic agent is not an opioid, opioid agonist, or an opioid antagonist. For example, the therapeutic agent can be an antiviral agent, antibiotic agent, antifungal agent, antibacterial agent, antiseptic agent, anti-protozoal agent, anti-parasitic agent, anti-inflammatory agent, a vasoconstrictor agent, a local anesthetic agent, an anti-diarrheal agent, an anti-hyperalgesia agent, or combinations thereof.

In one aspect of the invention, the S-MNTX is combined with an anti-diarrhea agent that is loperamide, loperamide analogs, N-oxides of loperamide and analogs, metabolites and prodrugs thereof, diphenoxylate, cisapride, antacids, aluminum hydroxide, magnesium aluminum silicate, magnesium carbonate, magnesium hydroxide, calcium carbonate, polycarbophil, simethicone, hyoscyamine, atropine, furazolidone, difenoxin, octreotide, lansoprazole, kaolin, pectin, activated charcoal, sulphaguanidine, succinylsulphathiazole, phthalylsulphathiazole, bismuth aluminate, bismuth subcarbonate, bismuth subcitrate, bismuth citrate, tripotassium dicitrate bismuthate, bismuth tartrate, bismuth subsalicylate, bismuth subnitrate and bismuth subgallate, opium tincture (paregoric), herbal medicines, plant-derived anti-diarrheal agents or combinations thereof.

In one aspect of the invention, the S-MNTX is combined with an anti-inflammatory agent that is a non-steroidal anti-inflammatory drug (NSAID), a tumor necrosis factor inhibitor, basiliximab, daclizumab, infliximab, mycophenolate, mofetil, azothioprine, tacrolimus, steroids, sulfasalazine, olsalazine, mesalamine, or combinations thereof.

The pharmaceutical preparations of the invention can take on a variety of forms, including, but not limited to a composition that is enteric coated, a composition that is a controlled release or sustained release formulation, a composition that is a solution, a

- 7 -

composition that is a topical formulation, a composition that is a suppository, a composition that is lyophilized, a composition that is in an inhaler, a composition that is in a nasal spray device, and the like. The composition can be for oral administration, parenteral administration, mucosal administration, nasal administration, topical administration, ocular administration, local administration, etc. If parenteral, the administration can be subcutaneous, intravenous, intradermal, intraperitoneal, intrathecal, etc.

According to another aspect of the invention, a method for synthesizing S-MNTX salt is provided. The method involves combining (iodomethyl) cyclopropane with oxymorphone in a first solvent to produce an iodo salt of S-MNTX. Counterions then may be substituted, optionally, for iodide by transferring the iodo salt S-MNTX to a second solvent and exchanging iodide for a counterion other than iodide. In one important embodiment, the iodo salt of S-MNTX is transferred from the first solvent to a second solvent, and the iodide is exchanged in the second solvent for bromide to produce a bromo salt of S-MNTX. The preferred first solvent is a dipolar aprotic solvent. Most preferred is N-methylpyrrolidone (NMP). The preferred second solvent is at least isopropyl acetate or dioxane. The method of the invention also involves purifying the salt of S-MNTX by chromatography, recrystallization, or a combination thereof. In one embodiment, the purification is by multiple recrystallizations. The reaction can be carried out across a wide temperature spectrum and at atmospheric conditions. In important embodiments, the reaction in the first solvent is conducted under a controlled reaction temperature between 65° to 75° C, preferable at about 70° C, and the reaction in the second solvent is conducted at room temperature.

More broadly, the method involves synthesizing S-MNTX plus counterion by combining a cyclopropylmethyl derivative with oxymorphone in a first solvent to produce the S-MNTX plus counterion. The cyclopropylmethyl derivative contains a leaving group. Preferably the leaving group is a halide or sulfonate. Preferably the leaving group is iodide. The first solvent may be a dipolar aprotic solvent. Examples of such solvents are N-methylpyrrolidone, dimethyl formamide, methylphosphoramidate, acetone, 1,4-dioxane, and acetonitrile and combinations thereof. Preferred is N-methylpyrrolidone. The first solvent can be a dipolar protic solvent. Examples are 2-propanol, 1-propanol, ethanol, methanol. The method can further involve exchanging the counterion of S-MNTX with another counterion. Examples of counterions are bromide,



- 8 -

chloride, fluoride, nitrate, sulfonate, or carboxylate. The sulfonate can be mesylate, besylate, tosylate or triflate. The carboxylate can be formate, acetate, citrate and fumarate. The method can involve transferring the S-MNTX counterion to a second solvent prior to exchanging the counterion of S-MNTX with another counterion. The method can further involve purifying the S-MNTX plus counterion, for example by  
5 recrystallization, by chromatography or by both.

According to another aspect of the invention, method is provided for inhibiting diarrhea in a subject, by administering to a subject in need of such treatment a pharmaceutical composition containing S-MNTX in an amount effective to treat or  
10 prevent the diarrhea. The pharmaceutical preparation can be of the type described above. The diarrhea can be acute or chronic. The diarrhea can be caused by any variety of circumstances, alone or combined, such as caused by an infectious agent, food intolerance, food allergy, malabsorption syndrome, reaction to a medication or nonspecific etiology. In some embodiments, the diarrhea is associated with irritable  
15 bowel disease or with inflammatory bowel disease. In one embodiment the inflammatory bowel disease is celiac disease. In another embodiment the inflammatory bowel disease is Crohn's disease. In yet another embodiment, the inflammatory bowel disease is ulcerative colitis. In other embodiments the diarrhea results from stomach or bowel resection, removal of a gall bladder, or organic lesions. In other embodiments, the  
20 diarrhea is associated with a carcinoid tumor or vasoactive intestinal polypeptide-secreting tumor. In still other embodiments, the diarrhea is chronic functional (idiopathic) diarrhea.

According to the invention, the S-MNTX may be administered in conjunction with an anti-diarrhea agent that is not S-MNTX. By in conjunction with, it is meant at  
25 the same time or close enough in time whereby both agents are treating the condition at the same time. In one embodiment, the agent is an opioid or an opioid agonist. In another embodiment, the agent is not an opioid or an opioid agonist.

According to another aspect of the invention, a method is provided for reducing a volume of discharge from a ileostomy or cholostomy in a subject. The method involves  
30 administering to a subject in need of such reduction a pharmaceutical composition containing S-MNTX in an amount effective to reduce the volume of discharge from the ileostomy or cholostomy. The pharmaceutical preparation can be of the type described above.

- 9 -

According to another aspect of the invention, a method is provided for reducing a rate of discharge from a ileostomy or cholostomy in a subject. The method involves administering to a subject in need of such reduction a pharmaceutical composition containing S-MNTX in an amount effective to reduce the rate of discharge from the  
5 ileostomy or cholostomy. The pharmaceutical preparation can be of the type described above.

According to another aspect of the invention, a method is provided for inhibiting gastrointestinal motility in a subject. The method involves administering to a subject in need of such inhibition a pharmaceutical composition containing S-MNTX in an amount  
10 effective to inhibit gastrointestinal motility in the subject. The pharmaceutical preparation can be of the type described above. According to the invention, the S-MNTX may be administered in conjunction with another motility inhibiting agent that is not S-MNTX. In one embodiment, the agent is an opioid or an opioid agonist. Opioids and opioid agonists are described above. In another embodiment, the agent is not an  
15 opioid or an opioid agonist. Examples of such gastrointestinal motility inhibiting agents are described below, each as if recited specifically in this summary of invention.

According to another aspect of the invention, a method is provided for treating irritable bowel syndrome. The method involves administering to a patient in need of such treatment a pharmaceutical composition containing S-MNTX in an amount  
20 effective to ameliorate at least one symptom of the irritable bowel syndrome. The pharmaceutical preparation can be of the type described above. In one embodiment, the symptom is diarrhea. In another embodiment, the symptom is alternating constipation and diarrhea. In another embodiment, the symptom is abdominal pain, abdominal bloating, abnormal stool frequency, abnormal stool consistency, or combinations thereof.

According to another aspect of the invention, a method is provided for inhibiting  
25 pain in a subject. The method involves administering to a patient in need of such treatment a pharmaceutical composition containing S-MNTX in an amount effective to inhibit the pain. The pharmaceutical preparation can be of the type described above. The method can further involve administering to the subject a therapeutic agent other  
30 than S-MNTX. In one embodiment the agent other than S-MNTX is an opioid. In another embodiment, the agent other than S-MNTX is a nonopioid pain relieving agent. Nonopioid pain relieving agents include corticosteroids and nonsteroidal anti-inflammatory drugs. Pain relieving agents are described in greater detail below, as if

- 10 -

recited herein this summary. In another embodiment, the agent other than S-MNTX is an antiviral agent, antibiotic agent, antifungal agent, antibacterial agent, antiseptic agent, anti-protozoal agent, anti-parasitic agent, anti-inflammatory agent, a vasoconstrictor agent, a local anesthetic agent, an anti-diarrheal agent, or an anti-hyperalgesia agent. If the pain is peripheral hyperalgesia, it can result, for example, from a bite, sting, burn, viral or bacterial infection, oral surgery, tooth extraction, injury to the skin and flesh, wound, abrasion, contusion, surgical incision, sunburn, rash, skin ulcers, mucositis, gingivitis, bronchitis, laryngitis, sore throat, shingles, fungal irritation, fever blisters, boils, plantar's warts, vaginal lesions, anal lesions, corneal abrasion, post-radial keratectomy, or inflammation. It also can be associated with post-surgery recovery. The surgery can be, for example, radial keratectomy, tooth extraction, lumpectomy, episiotomy, laparoscopy, and arthroscopy.

In some embodiments, the pharmaceutical composition is administered locally to a site of the pain. In some embodiments, the administration is intra-articular. In some embodiments, the administration is systemic. In some embodiments, the administration is topical. In some embodiments, the composition is administered to the eye.

According to another aspect of the invention, a method is provided for inhibiting inflammation in a subject. The method involves administering to a patient in need of such treatment a pharmaceutical composition containing S-MNTX in an amount effective to inhibit the inflammation. The pharmaceutical preparation can be of the type described above. The method can also involve administering to the subject a therapeutic agent other than S-MNTX. The therapeutic agent other than S-MNTX can be an anti-inflammatory agent. The administration can be, for example, local administration at a site of the inflammation, systemic administration, or topical administration.

The inflammation in some embodiments is periodontal inflammation, orthodontic inflammation, inflammatory conjunctivitis, hemorrhoids and venereal inflammations. In other embodiments, the inflammation is a skin inflammatory condition. Examples include inflammation associated with a disorder selected from the group consisting of irritant contact dermatitis, psoriasis, eczema, pruritus, seborrheic dermatitis, nummular dermatitis, lichen planus, acne vulgaris, comedones, polymorphs, nodulokystic acne, conglobata, senile acne, secondary acne, medical acne, a keratinization disorder, and blistery derma, atopic dermatitis, and UV-induced inflammation. The skin inflammatory condition also can be associated with skin sensitization or irritation arising from the use

- 11 -

of a cosmetic or skin care product which causes skin sensitization or irritation or can be a non-allergic inflammatory skin condition. It also can be induced by all-trans-retinoic acid. In other embodiments, the inflammation can be a systemic inflammatory condition. Examples include conditions selected from the group consisting of inflammatory bowel disease, rheumatoid arthritis, cachexia, asthma, Crohn's disease, endotoxin shock, adult respiratory distress syndrome, ischemic/reperfusion damage, graft-versus-host reactions, bone resorption, transplantation and lupus. Other embodiments can involve inflammation associated with a condition selected from the group consisting of multiple sclerosis, diabetes, and wasting associated with acquired immunodeficiency syndrome (AIDS) or cancer.

According to another aspect of the invention, a method is provided for inhibiting the production of tumor necrosis factor in a subject. The method involves administering to a patient in need of such treatment a pharmaceutical composition containing S-MNTX in an amount effective to inhibit the production of tumor necrosis factor. The pharmaceutical preparation can be of the type described above. The method can also involve administering to the subject a therapeutic agent other than S-MNTX.

According to another aspect of the invention, a method is provided for regulating gastrointestinal function in a subject. The method involves administering to a patient in need of such treatment a pharmaceutical composition containing S-MNTX and administering to the subject a peripheral mu opioid antagonist, both in amounts to regulate gastrointestinal function. In one embodiment, the peripheral mu opioid antagonist is R-MNTX.

According to another aspect of the invention, a method is provided. The method involves preventing or treating a psychogenic eating or digestive disorder by administering to a patient a composition described above in an amount effective to prevent or treat the psychogenic eating or digestive disorder.

According to another aspect of the invention, a kit is provided. The kit includes a package containing a sealed container of a pharmaceutical composition containing S-MNTX. The kit further can include a therapeutic agent other than S-MNTX. The therapeutic agent other than S-MNTX in one embodiment is an opioid or opioid agonist. In one aspect, the opioid or opioid agonist has substantially no CNS activity when administered systemically (i.e., is "peripherally acting"). In other embodiments, the therapeutic agent other than S-MNTX is an opioid antagonist. Opioid antagonists include

- 12 -

peripheral mu opioid antagonists. In one embodiment, the peripheral opioid antagonist is R-MNTX. In other embodiments, the agent other than S-MNTX is an antiviral agent, antibiotic agent, antifungal agent, antibacterial agent, antiseptic agent, anti-protozoal agent, anti-parasitic agent, anti-inflammatory agent, a vasoconstrictor agent, a local  
 5 anesthetic agent, an anti-diarrheal agent, or an anti-hyperalgesia agent, or combinations thereof.

According to another aspect of the invention, a method for analyzing S-MNTX in a mixture of R-MNTX and S-MNTX is provided. The method involves conducting high performance liquid chromatography (HPLC) and applying S-MNTX to the  
 10 chromatography column as a standard. The method preferably involves applying both S-MNTX and R-MNTX as standards to determine relative retention/elution times. Relative Retention times of R and S-MNTX are disclosed therein. In one aspect of this invention, the chromatography is conducted using two solvents, solvent A and solvent B, wherein solvent A is an aqueous solvent and solvent B is a methanolic solvent and wherein both  
 15 A and B contain trifluoroacetic acid (TFA). Preferably, A is 0.1% aqueous TFA and B is 0.1% methanolic TFA. In important embodiments the column comprises a bonded, end-capped silica. In important embodiments, the pore size of the column gel is 5 microns. In a most preferred embodiment, the column, flow rate and gradient program are as follows:

20 Column: Luna C18(2), 150 × 4.6 mm, 5 μ  
 Flow Rate: 1 mL/min  
 Gradient Program:

Time (min)	%A	%B
0:00	95	5
8:00	65	35
12:00	35	65
15:00	0	100
16:00	95	5
18:00	95	5

25 Detection can be carried out conveniently by ultraviolet (UV) @ 230 nm wavelength.

The foregoing HPLC also can be used to determine the relative amount of S-MNTX and R-MNTX by determining the area under the respective R and S curves in the chromatogram produced.

- 13 -

According to another aspect of the invention, methods are provided for ensuring the manufacture of S-MNTX (which is an opioid agonist) that is free of R-MNTX (which is an opioid antagonist). The methods permit for the first time the assurance that a pharmaceutical preparation of S-MNTX which is intended for agonist activity is not contaminated with a compound that opposes the activity of S-MNTX. In this aspect of the invention, a method is provided for manufacturing S-MNTX. The method involves: (a) obtaining a first composition containing S-MNTX, (b) purifying the first composition by chromatography, recrystallization or a combination thereof, (c) conducting HPLC on a sample of purified first composition using R-MNTX as a standard, and (d) determining the presence or absence of R-MNTX in the sample. In important embodiments, both R-MNTX and S-MNTX are used as standards to determine, for example, relative retention time of R-MNTX and S-MNTX. In one embodiment, the purifying is multiple recrystallization steps or multiple chromatography steps. In another embodiment, the purifying is carried out until R-MNTX is absent from the sample as determined by HPLC. It should be understood, however, that the "purified first composition" in some aspects of the invention is not necessarily free of detectable R-MNTX. The presence of such R-MNTX, for example, might indicate that further purification steps should be conducted if pure S-MNTX is desired. The methods can further involve packaging purified first composition that is free of HPLC detectable R-MNTX. The methods further can include providing indicia on or within the packaged, purified first composition indicating that the packaged, purified first composition is free of HPLC detectable R-MNTX. The method further can involve packaging a pharmaceutically effective amount for treating anyone of the conditions described herein. The first composition containing S-MNTX can be obtained by the methods described herein. Pure R-MNTX can be obtained as described herein.

According to another aspect of the invention, a packaged product is provided. The package contains a composition comprising S-MNTX, wherein the composition is free of HPLC detectable R-MNTX, and indicia on or contained within the package indicating that the composition is free of detectable R-MNTX. The composition can take on a variety of forms, including, but not limited to, a standard for use in laboratory experiments, a standard for use in manufacturing protocols, or a pharmaceutical composition. If the composition is a pharmaceutical composition, then one important form of indicia is writing on a label or package insert describing the characteristics of the

- 14 -

pharmaceutical preparation. The indicia can indicate directly that the composition is free of R-MNTX, or it can indicate the same indirectly, by stating for example that the composition is pure or 100% S-MNTX. The pharmaceutical composition can be for treating any of the conditions described herein. The pharmaceutical composition can contain an effective amount of the pure S-MNTX and can take any of the forms described below as if specifically recited in this summary, including, but not limited to, solutions, solids, semi-solids, enteric coated materials and the like.

These and other aspects of the invention are described in greater detail below.

10

### BRIEF DESCRIPTION OF DRAWINGS

FIG. 1 provides the chemical structure of bromide salts of R-MNTX and S-MNTX;

FIG. 2 illustrates a representative reaction scheme of the invention;

FIG. 3 provides a proton NMR spectrum of S-MNTX;

15

FIG. 4 provides an infrared spectrum of S-MNTX;

FIG. 5 provides an HPLC chromatogram of S-MNTX; and

FIG. 6 provides a mass spectrogram of S-MNTX.

FIG. 7 illustrates a kit according to the invention.

20

### DETAILED DESCRIPTION

The invention provides for the compound, S-MNTX, synthetic routes for stereoselective synthesis of S-MNTX, substantially pure S-MNTX, crystals of substantially pure S-MNTX, methods of analysis of S-MNTX, pharmaceutical preparations containing substantially pure S-MNTX, and methods for their use.

S-MNTX, also called (*S*)-*N*-(cyclopropylmethyl)-noroxymorphone methyl salt has the structure in Formula I:

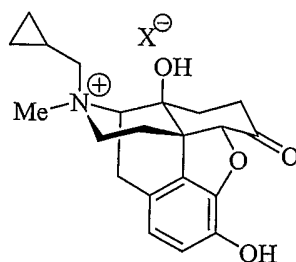

- 15 -

wherein X is a counterion. The counterion can be any counterion, including a zwitterion. Preferably the counterion is pharmaceutically acceptable. Counterions include halides, sulfates, phosphates, nitrates, and anionic-charged organic species. The halide can be iodide, bromide, chloride, fluoride, or combinations thereof. In one embodiment the halide is iodide. In a preferred embodiment the halide is bromide. The anionic-charged organic species may be a sulfonate or carboxylate.

It is believed that the methods of manufacture and the agonist properties of S-MNTX apply equally to S-quarternary derivatives of noroxymorphone other than where the derivative is cyclopropylmethyl. Thus, the invention is intended to embrace S-quarternary derivatives of noroxymorphone where the cyclopropylmethyl is replaced with a moiety R, where R is a 1-20 carbon hydrocarbyl consisting exclusively of carbon and hydrogen, including alkyl, alkenyl, alkynyl, and aryl, substituted or unsubstituted with hydrocarbons or with one or more atoms such as nitrogen, oxygen, silicon, phosphorus, boron, sulfur, or halogen (described in PCT publication WO 2004/043964.) In important embodiments, R is allyl, chloroallyl, or propargyl. In important embodiments, the hydrocarbyl contains 4-10 carbons.

"Alkyl", in general, refers to an aliphatic hydrocarbon group which may be straight, branched or cyclic having from 1 to about 10 carbon atoms in the chain, and all combinations and subcombinations of ranges therein. "Branched" refers to an alkyl group in which a lower alkyl group, such as methyl, ethyl or propyl, is attached to a linear alkyl chain. In certain preferred embodiments, the alkyl group is a C<sub>1</sub>-C<sub>5</sub> alkyl group, i.e., a branched or linear alkyl group having from 1 to about 5 carbons. In other preferred embodiments, the alkyl group is a C<sub>1</sub>-C<sub>3</sub> alkyl group, i.e., a branched or linear alkyl group having from 1 to about 3 carbons. Exemplary alkyl groups include methyl, ethyl, n-propyl, isopropyl, butyl, isobutyl, sec-butyl, tert-butyl, pentyl, hexyl, heptyl, octyl, nonyl and decyl. "Lower alkyl" refers to an alkyl group having 1 to about 6 carbon atoms. Preferred alkyl groups include the lower alkyl groups of 1 to about 3 carbons.

An "alkylating agent" is a compound that can be reacted with a starting material to bind, typically covalently, an alkyl group to the starting material. The alkylating agent typically includes a leaving group that is separated from the alkyl group at the time of attachment to the starting material. Leaving groups may be, for example, halogens, halogenated sulfonates or halogenated acetates. An example of an alkylating agent is cyclopropylmethyl iodide.



- 16 -

“Organic solvent” has its common ordinary meaning to those of skill in this art. Exemplary organic solvents useful in the invention include, but are not limited to tetrahydrofuran, acetone, hexane, ether, chloroform, acetic acid, acetonitrile, chloroform, cyclohexane, methanol, and toluene. Anhydrous organic solvents are included.

5 “Dipolar aprotic” solvents are protophilic solvents that cannot donate labile hydrogen atoms and that exhibit a permanent dipole moment. Examples include acetone, ethyl acetate, dimethyl sulfoxide (DMSO), dimethyl formamide (DMF) and N-methylpyrrolidone.

10 “Dipolar protic” solvents are those that can donate labile hydrogen atoms and that exhibit a permanent dipole moment. Examples include water, alcohols such as 2-propanol, ethanol, methanol, carboxylic acids such as formic acid, acetic acid, and propionic acid.

S-MNTX exhibits properties different from those of R-MNTX and different properties from a mixture of S- and R- MNTX. Those properties include mobility on chromatography columns, biological and functional activity, and crystal structure. It is believed that the *in vivo* clearance rate, the side-effect profile, and the like may also differ from R-MNTX or mixtures of R-MNTX and S-MNTX. As discovered and claimed herein, pure S-MNTX behaves as an agonist of peripheral opioid receptors as demonstrated by inhibition of gastrointestinal transit. As a consequence, S-MNTX activity may be interfered with or antagonized by R-MNTX in mixtures containing both R-MNTX and S-MNTX. It therefore is highly desirable to have S-MNTX in isolated and substantially pure form.

In one aspect of the invention, methods for the synthesis of S-MNTX are provided. S-MNTX may be produced at a purity of greater than or equal to 10%, 20%, 25 30%, 40%, 50 %, 60 %, 70 %, 75%, 80 %, 85 %, 90 %, 95 %, 97 %, 98 %, 98.5%, 99%, and 99.5% area under the curve (AUC) based on chromatographic techniques. In a preferred embodiment, the purity of S-MNTX is 98% or greater. The amount of R-MNTX in the purified S-MNTX may be less than or equal to about 90%, 80%, 70%, 60%, 50 %, 40 %, 30 %, 20 %, 10 %, 5 %, 3 %, 2 %, 1 %, 0.5 %, 0.3 %, 0.2 %, 0.1 % 30 (AUC) or undetectable by chromatographic techniques described herein. It will be appreciated by the skilled artisan that the detection of the methods will depend upon the detection and quantitation limits of the employed technique. Quantitation Limit is the lowest amount of R-MNTX that can be consistently measured and reported, regardless of

- 17 -

variations in laboratories, analysts, instruments or reagent lots. Detection Limit is the lowest amount of R-MNTX in a sample which can be detected but not necessarily quantitated as an exact value. In one embodiment of the invention the detection limit is 0.1% and the quantitation limit is 0.2%. In yet another embodiment the detection limit is  
5 0.02% and the quantitation limit is 0.05%.

Various synthetic protocols were attempted to synthesize S-MNTX. Many of the syntheses failed to make S-MNTX or failed to make S-MNTX at acceptable purity levels or yields. In the successful method of the invention, S-MNTX was synthesized via the direct alkylation of oxymorphone while leaving the phenolic OH group of oxymorphone  
10 unprotected (FIG. 2). Oxymorphone was reacted with the methylcyclopropane species iodomethyl cyclopropane. The S-MNTX salt that results includes a counterion such as iodide, that can then be exchanged for a preferred counterion such as bromide. The starting material in the synthesis of S-MNTX, oxymorphone, may be obtained at about 95 % yield through the demethylation of oxycodone, for example, with boron tribromide.  
15 Alternatively, the oxymorphone may be obtained through commercial sources.

An alkylation reaction may be performed in a solvent, or solvent system, that may be anhydrous. The solvent system may be a single solvent or may include a combination of two or more solvents. Suitable solvent systems may include dipolar aprotic solvents such as N-methylpyrrolidone (NMP), dimethyl formamide (DMF),  
20 hexamethylphosphoramide (HMPA), acetone, 1,4-dioxane and acetonitrile, and dipolar protic solvents such as 2-propanol. Solvent systems may also include dipolar aprotic solvents in combination with aliphatic ethers, such as tetrahydrofuran (THF), 1,2-dimethoxyethane (glyme), diethyleneglycol dimethyl ether (diglyme), 1,4-dioxane, methyl t-butyl ether (methyl 1,1,-dimethylethyl ether, or 2-methyl-2-methoxypropane)  
25 diethyl ether, other polar solvents may also be included in some embodiments. For instance, the solvent system may include acetone, methylethylketone, diethylketone (3-pentanone), and t-butylmethylketone(3,3-dimethylbutan-2-one). Alkylation solvent systems may also include aliphatic or alicyclic congeners of any of the compounds disclosed above. Solvent systems may include two or more solvents in any proportion  
30 and appropriate proportions for a particular alkylation reaction may be determined through routine experimentation. Notwithstanding the foregoing, surprisingly, NMP proved the preferred solvent.

- 18 -

The solvent may be used at a ratio of less than, greater than, or equal to about 1, 2, 3, 4, 5, 10 or more volumes. In some cases it may be preferred to minimize the amount of solvent used, such as when product is to be transferred from the solvent using a liquid/liquid extraction or when product is to be crystallized or when the solvent is to be removed from the product.

The alkylating agent may be added to the starting material in various molar ratios, such as less than 8, 12, 16, 20, 24 or greater than 24 equivalents per equivalent of starting material. In some instances, it has been found that reaction efficiency (production of S-MNTX) may be substantially independent of the amount of alkylating agent used.

In one set of embodiments, alkylation may be performed using the Finkelstein reaction. An alkyl halide, such as cyclopropylmethyl chloride, can be combined with a halide salt, such as sodium iodide, to continuously supply a reactive halogenated alkylating agent, such as cyclopropylmethyl iodide, that is replenished as it is consumed.

Starting materials may be alkylated at atmospheric pressure in an open vessel or under pressure. The reaction is conducted such that the temperature is maintained or controlled over the reaction time at a prescribed temperature using methods/equipment as are known in the art. One device for maintaining a controlled temperature throughout the alkylation reaction is a heater/chiller unit. Controlling the temperature throughout the alkylation reaction inhibits or reduces temperature fluctuations. In one embodiment, the temperature does not exceed 110° C, preferably does not exceed 100° C. For example, oxymorphone may be alkylated in an open or closed vessel over a range of from 50 to 100° C, 60 to 90° C, or 65 to 75° C. The reaction is allowed to proceed up to about 22 hours, preferably for about 15 to 22 hours, more preferably about 16 to 20 hours. It is contemplated that reaction times may be shortened through the use of microwave irradiation. In one embodiment, reactants are placed in a closed vessel at 70° C for about 17 hours to produce a product having a ratio of oxymorphone to S-MNTX of about 1:1. In a preferred embodiment, the alkylation is conducted at 70° C for about 20 hours in an open vessel (atmospheric pressure) wrapped to reduce exposure to light.

In some embodiments, S-MNTX may be isolated from the solvent in which it is produced. For example, the solvent may be removed from a residue containing the S-MNTX, or any S-MNTX may be transferred from the alkylation solvent to a transfer solvent. Transfer solvents may be polar or non-polar and may have boiling points below 100°C. Transfer solvents may include esters, aldehydes, ethers, alcohols, aliphatic

- 19 -

hydrocarbons, aromatic hydrocarbons and halogenated hydrocarbons. Specific transfer solvents include, for example, dioxane, ethyl acetate, isopropyl acetate, methanol, ethanol, dichloromethane, acetonitrile, water, aqueous HBr, heptane, and MTBE. In one embodiment, a mixture of isopropyl acetate and dioxane can be used to at least partially isolate S-MNTX from NMP. Upon mixing one or more of these solvents with a solution of S-MNTX in NMP, a light colored solid may develop that becomes an oil over time.

Any residue obtained from the solvent may be worked up to purify and isolate the product, S-MNTX. Purification and isolation may be done using methods known to those skilled in the art, such as by using separation techniques like chromatography, recrystallization, or combinations of various separation techniques as are known the art. In one embodiment, flash chromatography using a C18 column may be used with an aqueous methanol solvent modified with 0.2 % HBr. Methanol content may vary from, for example, about 2.5 % to about 50 %. In a preferred embodiment, the S-MNTX is purified using recrystallization. The process may be repeated until desired purity of product is obtained. In one embodiment, S-MNTX is recrystallized at least two times, three times, or four or more times to achieve the desired level of purity. For example, S-MNTX may be obtained at purities of greater than or equal to 50 %, 80 %, 85 %, 90 %, 95 %, 97 %, 98 %, 98.5 %, 99.8% (AUC) based on chromatographic techniques. Any impurities may include the starting material, oxymorphone of less than 0.2%, with no detectable R-MNTX. Recrystallization may be achieved using a single solvent, or a combination of solvents. A preferred recrystallization is achieved by dissolving S-MNTX in a polar solvent, and then adding a less polar cosolvent. In a more preferred embodiment, S-MNTX is purified by recrystallization from methanol and the cosolvent CH<sub>2</sub>Cl<sub>2</sub>/IPA (6:1). The recrystallization is repeated to achieve desired purity.

S-MNTX, and its derivatives, are produced in the salt form. Derivatives such as zwitterions of S-MNTX are included. S-MNTX, as shown in FIG. 1, may include a positively charged quaternary ammonium group and may be paired with a counterion such as a monovalent or multivalent anion. These anions may include, for example, halides, sulfates, phosphates, nitrates and charged organic species such as sulfonates and carboxylates. Preferred anions include halides such as bromide, chloride, iodide, fluoride, and combinations thereof. In some embodiments, bromide is most preferred. Specific anions may be chosen based on factors such as, for example, reactivity, solubility, stability, activity, cost, availability and toxicity.

- 20 -

Counterions of the S-MNTX salt can be exchanged for alternative counterions. When an alternative counterion is desired, an aqueous solution of an S-MNTX salt can be passed over an anion exchange resin column to exchange some or all of the counterion of the S-MNTX salt for a preferred alternative counterion. Examples of anion  
5 exchange resins include AG 1-X8 in a 100 to 200 mesh grade, available from Bio-Rad. In another embodiment, the S-MNTX cation can be retained on a cation exchange resin and can then be exchanged by removing the S-MNTX from the resin with a salt solution that includes a preferred anion, such as bromide or chloride, forming the desired S-MNTX salt in solution.

10 The S-MNTX of the present invention has numerous utilities. One aspect of the invention is S-MNTX as a chromatographic standard in identifying and distinguishing S-MNTX from other components in a sample in a chromatographic separation. Another aspect of the invention is the use of S-MNTX as a chromatographic standard in identifying and distinguishing S-MNTX in a mixture containing S-MNTX and R-  
15 MNTX. Isolated S-MNTX is also useful in the development of protocols for purifying and distinguishing S-MNTX from R-MNTX in reaction mixtures. Such protocols are described herein and also in co-pending application entitled "Synthesis of (*R*)-*N*-Methylnaltrexone", attorney docket number P0453.70119US00, filed on even date herewith.

20 The S-MNTX may be provided in a kit form with instruction for its use as a standard. The kit may further comprise an authentic R-MNTX as a standard. The S-MNTX for use as a standard preferably has a purity of 99.8% or greater with no detectable R-MNTX.

25 One aspect of the invention is a method of resolving and identifying S-MNTX and R-MNTX in a solution of MNTX. The S-MNTX also is useful in HPLC assay methods of quantifying an amount of S-MNTX in a composition or mixture in which the method comprises applying a sample of the composition or mixture to a chromatography column, resolving the components of the composition or mixture, and calculating the amount of S-MNTX in the sample by comparing the percentage of a resolved component  
30 in the sample with the percentage of a standard concentration of S-MNTX. The method is particularly useful in reverse phase HPLC chromatography. The S-MNTX of the present invention by virtue of its agonist activity on opioid receptors, is useful as a

- 21 -

standard of agonist activity in *in vitro* and *in vivo* opioid receptor assays such as those described herein.

The S-MNTX can be used to regulate a condition mediated by one or more peripheral opioid receptors, prophylactically or therapeutically, to agonize peripheral  
5 opioid receptors, in particular peripheral mu opioid receptors. The subjects being administered S-MNTX may receive treatment acutely, chronically or on an as needed basis.

The subjects to which the S-MNTX is administered are vertebrates, in particular mammals. In one embodiment the mammal is a human, nonhuman primate, dog, cat,  
10 sheep, goat, horse, cow, pig and rodent. In a preferred embodiment, the mammal is a human.

Mu and other opioid receptors exist in the gastrointestinal tract. Of the major classes of opioid receptors in the GI tract, mu receptors are principally involved in modulation of GI activity. Kappa opioid receptors may play a role (Manara L et al *Ann. Rev. Pharmacol. Toxicol.*, 1985, 25:249-73). In general, the S-MNTX is used to prevent  
15 or treat conditions associated with the need for activation or modulation of opioid receptors, in particular, peripheral opioid receptors. Of interest is the use of S-MNTX to prevent or treat conditions associated with the need for activation or modulation of opioid receptors in the GI tract, in particular mu opioid receptors. Such conditions which  
20 may be prevented or treated include diarrhea and used to prevent or inhibit certain forms of gastrointestinal dysfunction including certain forms of inflammatory bowel syndrome, and eating and digestive disorders.

In one aspect, S-MNTX can be used to treat diarrhea. Gastrointestinal function is regulated, at least in part, by one or more opioid receptors as well as endogenous opioids.  
25 Opioid antagonists are known to increase gastrointestinal motility and may thus be used effectively as a treatment for constipation. Opioid agonists on the other hand, in particular peripheral opioid agonists such as loperamide are known to decrease gastrointestinal motility and can be useful in treating diarrhea in mammals. S-MNTX as discovered by Applicants as an opioid agonist, can be administered to a patient in need of  
30 treatment for diarrhea. Diarrhea as used herein is defined as one or more of the following: 1) stool loose in consistency; 2) passing of greater than 3 stools per day; and/or 3) passing a stool volume of  $\geq 200$  g (150 ml) per day. S-MNTX is administered in an amount effective to prolong the transit time of intestinal contents resulting in

- 22 -

reduced fecal volume, increase fecal viscosity and bulk density and diminished loss of fluid and electrolytes.

The S-MNTX of the present invention by virtue of its opioid agonist activity is useful in the prevention and treatment of diarrhea having diverse etiology including acute and chronic forms of diarrhea, including chronic functional (idiopathic) diarrhea.

Acute diarrhea or short-term diarrhea as used herein is diarrhea lasting less than 1 week in duration, typically 1 to 3 days. Chronic diarrhea, ongoing or prolonged diarrhea as used herein is diarrhea lasting 1 week or longer duration. Chronic diarrhea may last for months or even years and may be continuous or intermittent. Various forms and causes of diarrhea which may benefit from treatment using S-MNTX include, but are not limited to those described below.

Viral gastroenteritis or "stomach flu" caused by any virus including but not limited to rotavirus, Norwalk virus, cytomegalovirus, herpes simplex virus, Hepatitis virus, and Adenovirus, is amenable to treatment using S-MNTX.

Food poisoning and traveler's diarrhea which occur from eating food or drinking water contaminated with organisms such as bacteria and parasites are amenable to treatment using S-MNTX. Bacteria commonly causing diarrhea include *Escherichia coli*, Salmonella, Shigella, Clostridia, Campylobacter, Yersinia, and Listeria. Parasites which cause diarrhea include *Giardia lamblia*, *Entamoeba histolytica*, and Cryptosporidium. Fungus which may cause diarrhea includes Candida.

Certain medical conditions can also lead to diarrhea including malabsorption syndromes such as lactose intolerance, celiac disease (sprue or gluten malabsorption), cystic fibrosis, intolerance to the protein in cows milk or other specific foods like beans, or fruits. Allergies to specific foods is another condition which may cause gastrointestinal irritation and/or allergic reaction leading to diarrhea. Typical food allergens include peanuts, corn and shellfish. Diarrhea caused by or associated with these medical conditions is amendable to treatment using S-MNTX of the present invention.

Other medical conditions that lead to diarrhea, in particular chronic diarrhea include inflammatory bowel diseases which include Crohn's disease and ulcerative colitis, irritable bowel syndrome (IBS) and immune deficiency may also benefit from S-MNTX to prevent or treat the diarrhea.

- 23 -

S-MNTX is useful in preventing and treating diarrhea caused by medications and/or therapies such as antibiotics, laxatives containing magnesium, chemotherapeutics for cancer treatment and high dose radiation therapy.

Diarrhea is also associated with Zollinger-Ellison syndrome, nerve disorders such as autonomic neuropathy or diabetic neuropathy, carcinoid syndrome, vasoactive intestinal polypeptide-secreting tumor, and anatomical conditions of the gastrointestinal tract including short bowel syndrome, gastrectomy, bowel resection with or without ileostomy or colostomy, and removal of the gall bladder. Such conditions are amenable to treatment using S-MNTX.

S-MNTX may be administered through any route, oral or parenteral, including intraperitoneal, intravenous, vaginal, rectal, intramuscular, subcutaneously, aerosol, nasal spray, transmucosal, transdermal, topical, colonic, and the like for the prevention and treatment of diarrhea.

S-MNTX is also useful in methods of reducing a volume of discharge from a ileostomy or cholestomy in a subject. The S-MNTX is provided in an amount effective to reduce the volume of discharge from the ostomy, compared to the volume of discharge from the ostomy in the absence of S-MNTX. S-MNTX is also useful in controlling the rate of discharge from an ostomy, in particular in reducing the rate of discharge in a subject in need of lower rate of discharge.

According to another aspect of the invention, a method is provided for inhibiting gastrointestinal motility in a subject. The method involves administering to a subject in need of such inhibition a pharmaceutical composition containing S-MNTX in an amount effective to inhibit gastrointestinal motility in the subject. According to the invention, the S-MNTX may be administered in conjunction with another motility inhibiting agent that is not S-MNTX. In one embodiment, the agent is an opioid or an opioid agonist. Opioids and opioid agonists are described above. In another embodiment, the agent is not an opioid or an opioid agonist. Examples of such nonopioid gastrointestinal motility inhibiting agents include, for example, cisapride, antacids, aluminum hydroxide, magnesium aluminum silicate, magnesium carbonate, magnesium hydroxide, calcium carbonate, polycarbophil, simethicone, hyoscyamine, atropine, furazolidone, difenoxin, octreotide, lansoprazole, kaolin, pectin, activated charcoal, sulphaguanidine, succinylsulphathiazole, phthalylsulphathiazole, bismuth-containing preparations such as bismuth aluminate, bismuth subcarbonate, bismuth subcitrate, bismuth citrate,



- 24 -

tripotassium dicitrato bismuthate, bismuth tartrate, bismuth subsalicylate, bismuth  
subnitrate and bismuth subgallate, opium tincture (paregoric), herbal medicines and  
plant-derived anti-diarrheal agents. Further such agents include benzodiazepine  
compounds, antispasmodic, selective serotonin reuptake inhibitors (SSRIs),  
5 cholecystokinin (CCK) receptor antagonists, natural killer (NK) receptor antagonists,  
Corticotropin Releasing Factor (CRF) receptor agonists, antacids, GI relaxants, anti-gas  
compounds, pentosan polysulfate, anti-emetic dopamine D2 antagonists, gonadotrophin-  
releasing hormone analogues (leuprolide), corticotrophin-1 antagonists, neurokinin 2  
receptor antagonists, cholecystokinin-1 antagonists, beta-blockers, anti-esophageal reflux  
10 agents, anti-inflammatory agents, 5HT<sub>1</sub> agonists, 5HT<sub>3</sub> antagonists, 5HT<sub>4</sub> antagonists,  
bile salt sequestering agents, bulk-forming agents, alpha<sub>2</sub>-adrenergic agonists,  
antidepressants such as tricyclic antidepressants. Additional such agents include  
antimuscarinic agents, ganglion blocking agents, hormones and hormone analogs, and  
motilin receptor antagonists. Antimuscarinic agents include belladonna alkaloids,  
15 quaternary ammonium antimuscarinic compounds and tertiary amine antimuscarinic  
compounds. Examples of belladonna alkaloids include belladonna leaf extracts,  
belladonna tincture, and belladonna extract. Examples of quaternary ammonium  
antimuscarinic agents include Anisotropine or Anisotropine methylbromide (Valpin),  
Clidinium or Clidinium bromide (Quarzan), Glycopyrrolate (Robinul), Hexocyclium  
20 methylsulfate (Tral), Homatropine, Ipratropium or Ipratropium bromide, Isopropamide  
or Isopropamide iodide (Darbid), Mepenzolate or Mepenzolate bromide (Cantil),  
Methantheline or Methantheline bromide (Banthine), Methscopolamine or  
Methscopolamine bromide (Pamine), Oxyphenonium, and Propantheline or  
Propantheline bromide. Examples of tertiary amine antimuscarinic agents include  
25 Atropine, Dicyclomine or Dicyclomine hydrochloride (Bentyl and others), Flavoxate  
hydrochloride (Urispas), Oxybutynin or Oxybutynin chloride (Ditropan),  
Oxyphencyclimine or Oxyphencyclimine hydrochloride (Daricon), Propiverine,  
Scopolamine, Tolterodine, and Tridihexethyl or Tridihexethyl chloride (Pathilon). Other  
antimuscarinic agents include Pirenzepine, Telenzepine, AF-DX116, Methoctranine,  
30 Himbacine, and Hexahydrosiladifenidol. Ganglion blocking agents include synthetic  
amines such as Hexamethonium, Mecamylamine, Tetraethylammonium, and  
Acetylcholine. Examples of hormones or hormone analogs that are anti-gastrointestinal  
motility agents include: somatostatin and somatostatin receptor agonists,. Examples of

- 25 -

somatostatin analogs include octreotide (e.g., Sandostatin®) and vapreotide. Motilin antagonists include (Phe<sup>3</sup>, Leu-13) porcine motilin, 214<sup>th</sup> American Chemical Society (ACS) Meeting (Part V); Highlights from Medicinal Chemistry Poster Session, Wednesday 10 September, Las Vegas, Nevada, (1997), Iddb Meeting Report September 5 7-11 (1997); and ANQ-1 1 125, Peeters T.L., et al., Biochem. Biophys. Res. Commun., Vol. 198(2), pp. 411-416 (1994).

In another aspect, S-MNTX may be used to treat eating and digestive disorders. Eating disorders and digestive disorders amenable to treatment using S-MNTX according to the invention comprise, but are not limited to, the regulation of pathological 10 imbalanced appetite, loss of appetite or diminished appetite, induced for example by pregnancy, cancer, infectious diseases such as influenza, HCV or HIV, as a result of catabolism, cachexy, anorexia, especially anorexia nervosa, dysorexia, dysponderosis, adiposity, bulimia, obesity, gastroparesis, especially neurogenic gastroparesis, diabetic gastroparesis, myogenic gastroparesis or gastroparesis induced by drugs, gastrotonia, 15 gastroparalysis or enteroparesis, and stenosis of the gastrointestinal tract, especially stenosis of the pylorus.

Pain has been defined in a variety of ways. For example, pain can be defined as the perception by a subject of noxious stimuli that produces a withdrawal reaction by the subject. Analgesia, is the reduction of pain perception. Agents that selectively block an 20 animal's response to a strong stimulus without obtunding general behavior or motor function are referred to as analgesics. Opiates and opioid agonists affect pain via interaction with specific opioid receptors. Given the discovery that S-MNTX has opiate agonist activity on gastrointestinal transit in rats, there is a rationale for using S-MNTX in treatment of pain.

25 In general, administration of S-MNTX and derivatives thereof according to the invention can be used to facilitate management of pain that is associated with any of a wide variety of disorders, conditions, or diseases. "Pain" as used herein, unless specifically noted otherwise, is meant to encompass pain of any duration and frequency, including, but not limited to, acute pain, chronic pain, intermittent pain, and the like. 30 Causes of pain may be identifiable or unidentifiable. Where identifiable, the origin of pain may be, for example, of malignant, non-malignant, infectious, non-infectious, or autoimmune origin. One embodiment is the management of pain associated with diseases, disorders, or conditions that require short-term therapy, e.g., dental procedures,

- 26 -

bone fractures, outpatient surgeries, for which therapy involves treatment over a period of hours up to 3 days. Of particular interest is the management of pain associated with disorders, diseases, or conditions that require long-term therapy, e.g., chronic and/or persistent diseases or conditions for which therapy involves treatment over a period of several days (e.g., about 3 days to 10 days), to several weeks (e.g., about 2 weeks or 4 weeks to 6 weeks), to several months or years, up to and including the remaining lifetime of the subject. Subjects who are not presently suffering from a disease or condition, but who are susceptible to such may also benefit from prophylactic pain management using the compositions and methods of the invention, e.g., prior to traumatic surgery. Pain amenable to therapy according to the invention may involve prolonged episodes of pain alternating with pain-free intervals, or substantially unremitting pain that varies in severity.

In general, pain can be nociceptive, somatogenic, neurogenic, or psychogenic. Somatogenic pain can be muscular or skeletal (i.e., osteoarthritis, lumbosacral back pain, posttraumatic, myofascial), visceral (i.e., pancreatitis, ulcer, irritable bowel), ischemic (i.e., arteriosclerosis obliterans), or related to the progression of cancer (e.g., malignant or non-malignant). Neurogenic pain can be due to posttraumatic and postoperative neuralgia, can be related to neuropathies (i.e., diabetes, toxicity, etc.), and can be related to nerve entrapment, facial neuralgia, perineal neuralgia, postamputation, thalamic, causalgia, and reflex sympathetic dystrophy.

Specific examples of conditions, diseases, disorders, and origins of pain amenable to management according to the present invention include, but are not necessarily limited to, cancer pain (e.g., metastasis or non-metastatic cancer), inflammatory disease pain, neuropathic pain, postoperative pain, iatrogenic pain (e.g., pain following invasive procedures or high dose radiation therapy, e.g., involving scar tissue formation resulting in a debilitating compromise of freedom of motion and substantial pain), complex regional pain syndromes, failed-back pain (e.g., acute or chronic back pain), soft tissue pain, joints and bone pain, central pain, injury (e.g., debilitating injuries, e.g., paraplegia, quadriplegia, etc., as well as non-debilitating injury (e.g., to back, neck, spine, joints, legs, arms, hands, feet, etc.)), arthritic pain (e.g., rheumatoid arthritis, osteoarthritis, arthritic symptoms of unknown etiology, etc.), hereditary disease (e.g., sickle cell anemia), infectious disease and resulting syndromes (e.g., Lyme disease, AIDS, etc.), headaches (e.g., migraines), causalgia, hyperesthesia,

- 27 -

sympathetic dystrophy, phantom limb syndrome, denervation, and the like. Pain can be associated with any portion(s) of the body, e.g., the musculoskeletal system, visceral organs, skin, nervous system, etc.

The methods of the invention can be used to manage pain in patients who are  
5 opioid naïve or who are no longer opioid naïve. Exemplary opioid naïve patients are those who have not received long-term opioid therapy for pain management. Exemplary non-opioid naïve patients are those who have received short-term or long-term opioid therapy and have developed tolerance, dependence, or other undesirable side effect. For example, patients who have intractable adverse side effects with oral, intravenous, or  
10 intrathecal morphine, transdermal fentanyl patches, or conventionally administered subcutaneous infusions of fentanyl, morphine or other opioid can achieve good analgesia and maintain favorable side-effects profiles with deliver of S-MNTX and derivatives thereof.

The term “pain management or treatment” is used here to generally describe  
15 regression, suppression, or mitigation of pain so as to make the subject more comfortable as determined by subjective criteria, objective criteria, or both. In general, pain is assessed subjectively by patient report, with the health professional taking into consideration the patient’s age, cultural background, environment, and other psychological background factors known to alter a person’s subjective reaction to pain.

20 As mentioned above, S-MNTX can be administered together with a therapeutic agent that is not S-MNTX, including but not limited, therapeutic agents that are pain relieving agents. In one embodiment, the pain relieving agent is an opioid or opioid agonist. In another embodiment, the pain relieving agent is a nonopioid pain relieving agent such as a corticosteroid or a nonsteroidal anti-inflammatory drug (NSAID). Pain  
25 relieving agents include: Alfentanil Hydrochloride; Aminobenzoate Potassium; Aminobenzoate Sodium; Anidoxime; Anileridine; Anileridine Hydrochloride; Anilopam Hydrochloride; Anirolac; Antipyrine; Aspirin; Benoxaprofen; Benzylamine Hydrochloride; Bicifadine Hydrochloride; Brifentanil Hydrochloride; Bromadoline Maleate; Bromfenac Sodium; Buprenorphine Hydrochloride; Butacetin; Butixirate;  
30 Butorphanol; Butorphanol Tartrate; Carbamazepine; Carbaspirin Calcium; Carbiphen Hydrochloride; Carfentanil Citrate; Ciprofadol Succinate; Ciramadol; Ciramadol Hydrochloride; Clonixeril; Clonixin; Codeine; Codeine Phosphate; Codeine Sulfate; Conorphone Hydrochloride; Cyclazocine; Dexoxadrol Hydrochloride; Dexpemedolac;

- 28 -

Dezocine; Diflunisal; Dihydrocodeine Bitartrate; Dimefadane; Dipyrone; Doxpicomine Hydrochloride; Drinidene; Enadoline Hydrochloride; Epirizole; Ergotamine Tartrate; Ethoxazene Hydrochloride; Etofenamate; Eugenol; Fenoprofen; Fenoprofen Calcium; Fentanyl Citrate; Floctafenine; Flufenisal; Flunixin; Flunixin Meglumine; Flupirtine  
5 Maleate; Fluproquazone; Fluradoline Hydrochloride; Flurbiprofen; Hydromorphone Hydrochloride; Ibuprofen; Indoprofen; Ketazocine; Ketorfanol; Ketorolac Tromethamine; Letimide Hydrochloride; Levomethadyl Acetate; Levomethadyl Acetate Hydrochloride; Levonantradol Hydrochloride; Levorphanol Tartrate; Lofemizole Hydrochloride; Lofentanil Oxalate; Lorcinadol; Lornoxicam; Magnesium Salicylate; Mefenamic Acid;  
10 Menabitan Hydrochloride; Meperidine Hydrochloride; Meptazinol Hydrochloride; Methadone Hydrochloride; Methadyl Acetate; Methopoline; Methotrimeprazine; Metkephamid Acetate; Mimbane Hydrochloride; Mirfentanil Hydrochloride; Molinazone; Morphine Sulfate; Moxazocine; Nabitan Hydrochloride; Nalbuphine Hydrochloride; Nalmexone Hydrochloride; Namoxyrate; Nantradol Hydrochloride;  
15 Naproxen; Naproxen Sodium; Naproxol; Nefopam Hydrochloride; Nexeridine Hydrochloride; Noracymethadol Hydrochloride; Ocfentanil Hydrochloride; Octazamide; Olvanil; Oxetorone Fumarate; Oxycodone; Oxycodone Hydrochloride; Oxycodone Terephthalate; Oxymorphone Hydrochloride; Pemedolac; Pentamorphone; Pentazocine; Pentazocine Hydrochloride; Pentazocine Lactate; Phenazopyridine Hydrochloride;  
20 Phenyramidol Hydrochloride; Picenadol Hydrochloride; Pinadoline; Pirfenidone; Piroxicam Olamine; Pravadoline Maleate; Prodilidine Hydrochloride; Profadol Hydrochloride; Propiram Fumarate; Propoxyphene Hydrochloride; Propoxyphene Napsylate; Proxazole; Proxazole Citrate; Proxorphan Tartrate; Pyrroliphen Hydrochloride; Remifentanil Hydrochloride; Salcolex; Salthamide Maleate;  
25 Salicylamide; Salicylate Meglumine; Salsalate; Sodium Salicylate; Spiradoline Mesylate; Sufentanil; Sufentanil Citrate; Talmecacin; Talniflumate; Talosalate; Tazadolene Succinate; Tebufelone; Tetrydamine; Tifurac Sodium; Tilidine Hydrochloride; Tiopinac; Tonazocine Mesylate; Tramadol Hydrochloride; Trefentanil Hydrochloride; Trolamine; Veradoline Hydrochloride; Verilopam Hydrochloride; Volazocine; Xorphanol Mesylate;  
30 Xylazine Hydrochloride; Zenazocine Mesylate; Zomepirac Sodium; Zucapsaicin, and combinations thereof.

Hyperalgesia is an increased sensitivity to pain or enhanced intensity of pain sensation. Hyperalgesia can result when a subject is hypersensitive to a stimulus,

- 29 -

resulting in an exaggerated pain response to a given stimulus . Hyperalgesia is often the result of a local inflammatory state and may follow trauma or injury to body tissue . Inflammation may follow, or be associated with, local infection, blisters, boils, skin injury such as cuts, scrapes, burns, sunburns, abrasions, surgical incisions, inflammatory skin conditions such as poison ivy, allergic rashes, insect bites and stings, and joint inflammation. S-MNTX can be used to prevent and treat peripheral hyperalgesia and to reduce pain and/or symptoms resulting from inflammation. As used herein, hyperalgesia includes pruritis, or itching, and S-MNTX may be used as an anti-pruritic treatment.

The compositions and methods herein are intended for the preventions and treatment of hyperalgesia association with numerous inflammatory conditions and injuries. The compositions and methods provided herein may be used to treat a variety of hyperalgesic conditions associated with burns, including, but not limited to, thermal, radiation, chemical, sun and wind burns, abrasions, including, for example, corneal abrasions, bruises, contusions, frostbite, rashes, including, for example, allergic heat and contact dermatitis, such as, for example, poison ivy and diaper rashes, acne, insect bites/stings, skin ulcers, including, but not limited to, diabetic and decubitus ulcers, mucositis, inflammation, for example, periodontal inflammation, orthodontic inflammation, inflammation/irritation arising from use of a cosmetic or skin care product, inflammatory conjunctivitis, hemorrhoids and venereal inflammations, gingivitis, bronchitis, laryngitis, sore throat, singles, fungal irritation, for example, athlete's foot and jock itch, fever blisters, boils, plantar's warts or vaginal lesions, including, for example, mycotic and sexually transmitted vaginal lesions.

Hyperalgesic conditions associated with skin surfaces include burns, including but not limited to, thermal, radiation, chemical, sun and wind burns, abrasions such as, for example, corneal abrasions, bruises, contusions, frostbite, rashes including allergic, heat contact dermatitis (for example, poison ivy) and diaper rashes), acne insect bites/stings and skin ulcers (including diabetic and decubitus ulcers). Hyperalgesic conditions of the mouth, larynx and bronchium include mucositis, post-tooth extraction, periodontal inflammation, gingivitis, orthodontic inflammation, bronchitis, laryngitis and sore throat. Hyperalgesic conditions of the eyes include corneal abrasions, post-radial keratectomy and inflammatory conjunctivitis. Hyperalgesic conditions of the rectum/anus include hemorrhoids and venereal inflammations. Hyperalgesic conditions associated with infectious agents include shingles, fungal irritations (including athlete's

- 30 -

foot and jock itch), fever blisters, boils, plantar's warts and vaginal lesions (including lesions associated with mycosis and sexually transmitted diseases). Hyperalgesic conditions may also be associated with recovery following surgery, such as recovery following lumpectomy, episiotomy, laparoscopy, arthroscopy, radial keratectomy and  
5 tooth extraction.

As a preventative or treatment for peripheral hyperalgesia, S-MNTX can be administered using any pathway that provides for delivery of the compound to an afflicted area. Administration may be oral or parenteral. Methods of administration also include topical and local administration. S-MNTX can be applied to any body surface  
10 including skin, joints, eyes, lips and mucosal membranes.

S-MNTX may be delivered in combination with other compounds, such as those disclosed herein, that provide anti-hyperalgesic effects, including, but not limited to, pain medications, itching medications, anti-inflammatory agents, and the like. S-MNTX also may be administered with other compounds used to treat the conditions causing the  
15 inflammation, such as antivirals, antibacterials, antifungals, and anti-infectives. These other compounds may act and be administered locally or systemically and may be part of the same composition or may be administered separately. Such compounds are described in greater detail below.

Inflammation is often associated with an increase in Tumor Necrosis Factor  
20 (TNF) production and it is believed that a decrease in TNF production will result in a reduction in inflammation. Peripherally acting opioid agonists have been shown to decrease TNF production (U.S. Patent No. 6,190,691). The peripherally selective k-opioid, asimadoline, has been shown to be a potent anti-arthritis agent in an adjuvant-induced arthritis animal model (Binder, W. and Walker, J.S. *Br. J. Pharma* 124:647-  
25 654). Thus the peripheral opioid agonist activity of S-MNTX and derivatives thereof provide for prevention and treatment of inflammatory conditions. While not being bound by theory, the anti-inflammatory effect of S-MNTX and derivatives thereof may be through inhibition of TNF production, directly or indirectly. The S-MNTX or derivatives thereof may be administered systemically or locally. S-MNTX may be  
30 administered in combination with another TNF inhibitor such as loperamide and diphenoxylate or with other anti-inflammatory agents described herein.

Another aspect of the present invention is prevention and/or treatment of a systemic inflammatory condition, preferably inflammatory bowel disease, rheumatoid

- 31 -

arthritis, cachexia, asthma, Crohn's disease, endotoxin shock, adult respiratory distress syndrome, ischemic/reperfusion damage, graft-versus-host reactions, bone resorption, transplantation or lupus using S-MNTX or derivatives thereof.

In still another group of embodiments, the inflammatory condition amenable to  
5 treatment using S-MNTX or derivatives thereof is associated with multiple sclerosis, diabetes or wasting associated with acquired immunodeficiency syndrome (AIDS) or cancer.

In one group of embodiments, a skin inflammatory condition, preferably  
psoriasis, atopic dermatitis, UV-induced inflammation, contact dermatitis or  
10 inflammation induced by other drugs, including, but not limited to RETIN-A (all-trans-retinoic acid) is amenable to treatment using S-MNTX or derivative thereof.

Another aspect of the invention is a method of treating a non-allergic  
inflammatory skin condition comprising the administration of S-MNTX in an amount  
effective to treat the inflammatory condition. Non-allergic inflammatory skin conditions  
15 are associated with irritant contact dermatitis, psoriasis, eczema, pruritus, seborrheic dermatitis, nummular dermatitis, lichen planus, acne vulgaris, comedones, polymorphs, nodulokystic acne, conglobata, senile acne, secondary acne, medicinal acne, a keratinization disorder, and blistering dermatoses.

Certain patients particularly amenable to treatment are patients having the  
20 symptoms of any one of the foregoing conditions. The patients may have failed to obtain relief or ceased to obtain relief or a consistent degree of relief of their symptoms using other therapies. Such patients are said to be refractory to the conventional treatments. The condition may be induced or a consequence of one or more diverse conditions including, but not limited to, a disease condition, a physical condition, a drug-induced  
25 condition, a physiological imbalance, stress, anxiety, and the like. The conditions may be an acute condition or chronic condition.

Subjects can be treated with a combination of the S-MNTX and a therapeutic  
agent other than the S-MNTX. In these circumstances the S-MNTX and the other  
therapeutic agent(s) are administered close enough in time such that the subject  
30 experiences the effects of the various agents as desired, which typically is at the same time. In some embodiments the S-MNTX will be delivered first in time, in some embodiments second in time, and still in some embodiments at the same time. As discussed in greater detail below, the invention contemplates pharmaceutical



- 32 -

preparations where the S-MNTX is administered in a formulation including another pharmaceutical agent. These formulations may be such as those described in U.S. Patent Application Serial No. 10/821,809, which is hereby incorporated by reference in its entirety herein. Included are solid, semisolid, liquid, controlled release and other such formulations.

One important class of therapeutic agent which can be part of the prevention and treatment protocol together with the S-MNTX are opioids. It has been surprisingly found by Applicants that S-MNTX used in combination with the opioid, morphine results in an enhanced and apparently synergistic inhibition of gastrointestinal transit. Thus, the present invention provides pharmaceutical compositions comprising S-MNTX in combination with one or more opioids. This will permit alteration of doses not previously obtainable. For example, where a lower dose of opioid is desirable in treating certain peripherally mediated conditions this now is possible by combination with S-MNTX treatment.

The opioid can be any pharmaceutically acceptable opioid. Common opioids are those selected from the group consisting of alfentanil, anileridine, asimadoline, bremazocine, burprenorphine, butorphanol, codeine, dezocine, diacetylmorphine (heroin), dihydrocodeine, diphenoxylate, fedotozine, fentanyl, funaltrexamine, hydrocodone, hydromorphone, levallorphan, levomethadyl acetate, levorphanol, loperamide, meperidine (pethidine), methadone, morphine, morphine-6-glucuronide, nalbuphine, nalorphine, opium, oxycodone, oxymorphone, pentazocine, propiram, propoxyphene, remifentanyl, sufentanil, tilidine, trimebutine, and tramadol.

Depending on the desired effect to be achieved the opioid may be administered parenterally or other systemic route to affect both the central nervous system (CNS) and peripheral opioid receptors. The desired effect of the opioid in combination with S-MNTX may be prevention or treatment of diarrhea, prevention or treatment of pain from any cause or etiology including prevention or treatment of peripheral hyperalgesia. When the indication is prevention or treatment of peripheral hyperalgesia, it is desirable to provide an opioid which does not have concomitant CNS effects or alternatively to administer the opioid topically or locally such that the opioid does not substantially cross the blood brain barrier but provide an effect on peripheral opioid receptors.

Opioids particularly useful for prevention or treatment of diarrhea or prevention or treatment of peripheral hyperalgesia in combination with S-MNTX include but are not limited to:

- (i) loperamide [4-(p-chlorophenyl)-4-hydroxy-N-N-dimethyl- $\alpha,\alpha$ -diphenyl-1-piperidinebutyramide hydrochloride]], loperamide analogs and related compounds as defined herein [see, U.S. Pat. Nos. 3,884,916 and 3,714,159; see, also U.S. Pat. Nos. 4,194,045, 4,116,963, 4,072,686, 4,069,223, 4,066,654.], N-oxides of loperamide and analogs, metabolites and prodrugs thereof and related compounds as defined herein [see, also, U.S. Pat. No. 4,824,853], and related compounds, such as (a), (b) and (c) as follows:
- (a) 4-(aroylamino)pyridine-butanamide derivatives and N-oxides thereof as defined herein [see, also U.S. Patent No. 4,990,521];
- (b) 5-(1,1-diphenyl-3-(5- or 6-hydroxy-2-azabicyclo-(2.2.2)oct-2-yl)propyl)-2-alkyl-1,3,4-oxadiazoles, 5-(1,1-diphenyl-4-(cyclic amino)but-2-trans-en-1-yl)-2-alkyl-1,3,4-oxadiazoles, 2-[5-(cyclic amino)-ethyl-10,11-dihydro-5H-dibenzo[a,d]-cyclohepten-5-yl]-5-alkyl-1,3,4-oxadiazoles] and related compounds [see, U.S. Pat. Nos. 4,013,668, 3,996,214 and 4,012,393];
- (c) 2-substituted-1-azabicyclo[2,2,2]octanes [see, U.S. Pat. No. 4,125,531];
- (ii) 3-hydroxy-7-oxomorphinans and 3-hydroxy-7-oxoisomorphinans [see, e.g., U.S. Pat. No. 4,277,605]
- (iii) amidinoureas as provided herein [see, also U.S. Pat. Nos. 4,326,075, 4,326,074, 4,203,920, 4,060,635, 4,115,564, 4,025,652] and 2-[(aminophenyl and amidophenyl)amino]-1-azacycloalkanes [see, U.S. Pat. No. 4,533,739];
- (iv) metkephamid [H-L-Tyr-D-Ala-Bly-L-Phe-N(Me)Met-NH<sub>2</sub>; see, e.g., U.S. Pat. No. 4,430,327; Burkhart et al. (1982) *Peptides* 3-869-871; Frederickson et al. (1991) *Science* 211:603-605] and other synthetic opioid peptides, such as H-Tyr-D-Nva-Phe-Orn-NH<sub>2</sub>, H-Tyr-D-Nle-Phe-Orn-NH<sub>2</sub>, H-Tyr-D-Arg-Phe-A<sub>2</sub>bu-NH<sub>2</sub>, H-Tyr-D-Arg-Phe-Lys-NH<sub>2</sub>, and H-Lys-Tyr-D-Arg-Phe-Lys-NH<sub>2</sub> [see, U.S. Pat. No. 5,312,899; see, also Gesellchen et al. (1981) *Pept.: Synth., Struct., Funct., Proc. Am. Pept. Symp.*, 7<sup>th</sup>.; Rich et al., (Eds), Pierce Chem. Co., Rochford, Ill., pp. 621-62] that do not cross the blood brain barrier;
- (v) propanamines as defined in U.S. Pat. No. 5,236,947 and the like.

- 34 -

S-MNTX may also be used to treat diarrhea in combination with other anti-diarrheal compounds and compositions. For example, S-MNTX may be administered to a subject in combination with a known anti-diarrheal agent. Two or more compounds may be administered in a cocktail or the compounds may be administered separately  
5 using the same or different administration routes. Known anti-diarrheal agents include, for example, loperamide, loperamide analogs, N-oxides of loperamide and analogs, metabolites and prodrugs thereof, diphenoxylate, cisapride, antacids, aluminum  
1 hydroxide, magnesium aluminum silicate, magnesium carbonate, magnesium hydroxide, calcium carbonate, polycarbophil, simethicone, hyoscyamine, atropine, furazolidone,  
10 difenoxin, octreotide, lansoprazole, kaolin, pectin, activated charcoal, sulphaguanidine, succinylsulphathiazole, phthalylsulphathiazole, bismuth aluminate, bismuth  
subcarbonate, bismuth subcitrate, bismuth citrate, tripotassium dicitrate bismuthate, bismuth tartrate, bismuth subsalicylate, bismuth subnitrate and bismuth subgallate,  
opium tincture (paregoric), herbal medicines and plant-derived anti-diarrheal agents.

15 Other therapeutic agents which can be part of treatment protocols together with S-MNTX are irritable bowel syndrome (IBS) agents, antibiotics, antivirals, anti-fungals, anti-infectives, anti-inflammatory agents including anti-histamines, vasoconstrictors, anti-diarrheals, and the like.

IBS therapeutic agents which may be used in combination with S-MNTX include,  
20 but are not limited to, benzodiazepine compounds, antispasmodic, selective serotonin reuptake inhibitors (SSRIs), cholecystokinin (CCK) receptor antagonists, motilin  
receptor agonists or antagonists, natural killer (NK) receptor antagonists, Corticotropin Releasing Factor (CRF) receptor agonists or antagonists, somatostatin receptor agonists,  
antacids, GI relaxants, anti-gas compounds, bismuth-containing preparations, pentosan  
25 polysulfate, anti-emetic dopamine D2 antagonists, prostaglandin E analogs, gonadotrophin-releasing hormone analogues (leuprolide), corticotrophin-1 antagonists,  
neurokinin 2 receptor antagonists, cholecystokinin-1 antagonists, beta-blockers, anti-esophageal reflux agents, anti-muscarinics, antidiarrheals, anti-inflammatory agents,  
anti-motility agents, 5HT<sub>1</sub> agonists, 5HT<sub>3</sub> antagonists, 5HT<sub>4</sub> antagonists, 5HT<sub>4</sub> agonists,  
30 bile salt sequestering agents, bulk-forming agents, alpha<sub>2</sub>-adrenergic agonists, mineral oils, antidepressants, herbal medicines.

Specific examples of IBS therapeutic agents include, but are not limited to, the following:

- 35 -

Benzodiazepine compounds and analogs which act to suppress seizures through an interaction with gamma-aminobutyric acid (GABA) receptors of the A-type (GABA<sub>A</sub>), for example, DIASTAT® and VALIUM®; LIBRIUM®; and ZANAX®.

SSRIs, for example, fluvoxamine; fluoxetine; paroxetine; sertraline; citalopram; 5 venlafaxine; cericlamine; duloxetine; milnacipran; nefazodone; and cyanodothiepin (See The Year Drugs News, 1995 Edition, pp. 47-48 by Prous J.R.) and WO 97/29739.

CCK receptor antagonists, for example, devazepide; lorglumide; dexioxiglumide; loxiglumide, D'Amato, M. et al., Br. J. Pharmacol. Vol. 102(2), pp. 391-395 (1991); CI 988; L364,718; L3637260; L740,093 and LY288,513; CCK receptor antagonists 10 disclosed in U. S. Patent No. 5,220,017, Bruley-Des-Varannes, S, et al. Gastroenterol. Clin. Biol. Vol.15.(10)9 pp. 744-757 (1991), and Worker C: EUPHAR'99- Second European Congress of Pharmacology (Part IV) Budapest, Hungary Iddb Meeting Report 1999 July 3-7.

Motilin receptor agonists or antagonists which include e.g. motilin agonist ABT- 15 269, (erythromycin, 8,9-didehydro-N-dimethyl deoxo-4",6,12-trideoxy-6,9-epoxy-N-ethyl), de(Nmethyl-N-ethyl-8,9-anhydroerythromycin A) and de(N-methyl)-N-isoprop-8,9anhydroerythromycin A), Sunazika T. et al., Chem. Pharm. Bull., Vol. 37(10), pp. 2687-2700 (1989); A-173508 (Abbot Laboratories); motilin antagonists (Phe<sup>3</sup>, Leu-13) porcine motilin, 214<sup>th</sup> American Chemical Society (ACS) Meeting (Part V); Highlights 20 from Medicinal Chemistry Poster Session, Wednesday 10 September, Las Vegas, Nevada, (1997), Iddb Meeting Report September 7-11 (1997); and ANQ-1 1 125, Peeters T.L., et al., Biochem. Biophys. Res. Commun., Vol. 198(2), pp. 411-416 (1994).

NK receptor antagonists which include e.g. FK 888( Fujisawa); GR 205171 (Glaxo Wellcome); LY 303870 (Lilly); MK 869 (Merck); GR82334 (Glaxo Wellcome); 25 L758298 (Merck); L 733060 (Merck); L 741671 (Merck); L 742694 (Merck); PD 154075 (Parke-Davis); S1 8523 (Servier); S1 9752 (Servier); OT 7100 (Otsuka); WIN 51708 (Sterling Winthrop); NKP-608A; TKA457; DNK333; CP-96345; CP-99994; CP122721; L-733060; L-741671; L742694; L-758298; L-754030; GR-203040; GR-205171; RP-67580; RPR-100893 (dapitant); RPR-107880; RPR-111905; FK-888; SDZ- 30 NKT-343; MEN-10930; MEN-11149; S-18523; S-19752; PD-154075 (CAM-4261); SR-140333; LY-303870 (lanepitant); EP-00652218; EP00585913; L-737488; CGP-49823; WIN-51708; SR-48968 (saredutant); SR-144190; YM383336; ZD-7944; MEN-10627; GR-159897; RPR-106145; PD-147714 (CAM-2291); ZM253270; FK-224; MDL-1

- 36 -

05212A; MDL-105172A; L-743986; L-743986 analogs; S-16474; SR-1 42801 (osanetant); PD-161182; SB-223412; and SB-222200.

CRF receptor agonists or antagonists, e.g. as disclosed in WO 99/40089, AXC 2219, Antalarmin, NGD 1, CRA 0165, CRA 1000, CRA 1001.

5 Somatostatin receptor agonists, e.g. octreotide, vapreotide, lanreotide.

Anti-inflammatory compounds, particularly those of the immuno-modulatory type, for example, NSAIDS; Tumor Necrosis Factor (TNF, TNF $\alpha$ ) inhibitors; basiliximab (e.g. SIMULECT®); daclizumab (e.g. ZENAPAX®); infliximab (e.g. REMICADE®); etanercept (e.g. ENBREL®) mycophenolate mofetil (e.g. CELLCEPT®); azathioprine (e.g. IMURAN®); tacrolimus (e.g. PROGRAF®); steroids; 10 methotrexate and GI anti-inflammatory agents, for example, sulfasalazine (e.g. AZULFIDINE®); olsalazine (e.g. DIPENTUM®); and mesalamine (e.g. ASACOL®, PENTASA®, ROWASA®).

Antacids, such as aluminum and magnesium antacids; and calcium hydroxides 15 such as MAALOX®.

Anti-gas compounds, for example, simethicone marketed under the trade names MYLANTA® and MYLICON®; and enzyme preps including PHAZYME® and BEANO®.

Bismuth-containing preparations, for example, bismuth subsalicylate also known 20 as PEPTO-BISMOL®.

Pentosan polysulfate, a heparin-like macromolecular carbohydrate derivative which chemically and structurally resembles glycosaminoglycans, marketed under the trade name ELMIRON®.

Anti-emetic dopamine D2 antagonists which include e.g. domperidone.

25 Prostaglandin E analogs, gonadotrophin-releasing hormone analogues (leuprolide), corticotrophin-1 antagonists, neurokinin 2 receptor antagonists, cholecystokinin-1 antagonists, beta-blockers.

Anti-esophageal reflux agents include but are not limited to PRILOSEC®.

Antispasmodics and anti-muscarinics include, but are not limited to, dicyclomine, 30 oxybutynin (e.g., oxybutynin chloride), tolterodine (e.g., tolterodine tartarate), alverine anisotropine, atropine (e.g., atropine sulfate), belladonna, homatropine, homatropine methobromide, hyoscyamine (e.g., hyoscyamine sulfate), methscopolamine, scopolamine

- 37 -

(e.g., scopolamine hydrochloride), clidinium, cimetropium, hexocyclium, pinaverium, otilonium, glycopyrrolate, and mebeverine.

Antidiarrheals include, but are not limited to, ipratropium, isopropamide, mepenzolate, propantheline, oxyphenycyclimine, pirenzepine, diphenoxylate (e.g.,  
5 diphenoxylate hydrochloride), atropine sulfate, alosetron hydrochloride, difenoxin hydrochloride, bismuth subsalicylate, lactobacillus acidophilus, trimebutine, asimadoline, and octreotide acetate.

Anti-inflammatory agents also include, but are not limited to, mesalamine, sulfasalazine, balsalazide disodium, hydrocortisone, and olsalazine sodium.

10 5HT<sub>1</sub> agonists include, but are not limited to, buspirone.

5HT<sub>3</sub> antagonists include, but are not limited to, ondansetron, cilansetron, and alosetron.

5HT<sub>4</sub> antagonists include, but are not limited to, pipsocrod.

15 5HT<sub>4</sub> agonists include, but are not limited to, tegaserod (e.g., tegaserod maleate), and povcalopride.

Antidepressants include, but are not limited to, desipramine, amitriptyline, imipramine, fluoxetine, and paroxetine.

Other IBS therapeutic agents include dexloiglumide, TAK-637, talnetant, SB 223412, AU 244, neurotrophin-3, GT 160-246, immunoglobulin (IgG), ramoplanin,  
20 risaxmin, rimethicone, darifenacine, zamifenacin, loxiglumide, misoprostil, leuprolide, domperidone, somatostatin analogues, phenytoin, NBI-34041, saredutant, and dexloiglumide.

Antibiotics include, but are not limited to, tetracycline antibiotics, such as chlortetracycline, oxytetracycline, tetracycline, demethylchlortetracycline, metacycline,  
25 doxycycline, minocycline and rolitetracycline; such as kanamycin, amikacin, gentamicin C<sub>1a</sub>, C<sub>2</sub>, C<sub>2b</sub> or C<sub>1</sub>, sisomicin, netilmicin, spectinomycin, streptomycin, tobramycin, neomycin B, dibekacin and kanandomycin; macrolides, such as maridomycin and erythromycin; lincomycins, such as clindamycine and lincomycin; penicillanic acid (6-APA)- and cephalosporanic acid (7-ACA)-derivatives having (6 $\beta$ - or 7 $\beta$ -acylamino  
30 groups, respectively, which are present in fermentatively, semi-synthetically or totally synthetically obtainable 6 $\beta$ -acylamino penicillanic acid or 7 $\beta$ -acylaminocephalosporanic acid derivatives and/or 7 $\beta$ -acylaminocephalosporanic acid derivatives that are modified in the 3-position, such as penicillanic acid derivatives that have become known under the

- 38 -

names penicillin G or V, such as phenethicillin, propicillin, nafcillin, oxycillin, cloxacillin, dicloxacillin, flucloxacillin, cyclacillin, epicillin, mecillinam, methicillin, azlocillin, sulbenicillin, ticarcillin, mezlocillin, piperacillin, carindacillin, azidocillin or ciclacillin, and cephalosporin derivatives that have become known under the names  
5 cefaclor, cefuroxime, cefazlur, cephacetrile, cefazolin, cephalixin, cefadroxil, cephaloglycin, cefoxitin, cephaloridine, cefsulodin, cefotiam, ceftazidime, cefonicid, cefotaxime, cefmenoxime, ceftizoxime, cephalothin, cephradine, cefamandol, cephanone, cephapirin, cefroxadin, cefatrizine, cefazedone, ceftriaxon and ceforanid; and  
10 other  $\beta$ -lactam antibiotics of the clavam, penem and carbapenem type, such as moxalactam, clavulanic acid, nocardicine A, sulbactam, aztreonam and thienamycin; and other antibiotics including bicozamycin, novobiocin, chloramphenicol or thiamphenicol, rifampicin, fosfomycin, colistin, and vancomycin.

Antiviral agents include, but are not limited to, nucleoside analogs, nonnucleoside reverse transcriptase inhibitors, nucleoside reverse transcriptase  
15 inhibitors, protease inhibitors, integrase inhibitors, including the following: acemannan; acyclovir; acyclovir sodium; adefovir; alovudine; alvircept sudotox; amantadine hydrochloride; arantoin; arildone; atevirdine mesylate; avridine; cidofovir; cipamfylline; cytarabine hydrochloride; delavirdine mesylate; desciclovir; didanosine; disoxaril; edoxudine; enviroxime; famciclovir; famotone hydrochloride; fiacitabine;  
20 fialuridine; fosarilate; foscarnet sodium; fosfonet sodium; ganciclovir; ganciclovir sodium; idoxuridine; indinavir; kethoxal; lamivudine; lobucavir; lopinavir; memotone hydrochloride; methisazone; nelfinavir; nevirapine; penciclovir; pirodavar; ribavirin; rimantadine hydrochloride; ritonavir; saquinavir mesylate; somantadine hydrochloride; sorivudine; statolon; stavudine; tenofovir; tilorone hydrochloride; trifluridine;  
25 valacyclovir hydrochloride; vidarabine; vidarabine phosphate; vidarabine sodium phosphate; viroxime; zalcitabine; zert; zidovudine (AZT); and zinviroxime.

Anti-infective agents include, but are not limited to, difloxacin hydrochloride; lauryl isoquinolinium bromide; moxalactam disodium; ornidazole; pentisomicin; sarafloxacin hydrochloride; protease inhibitors of HIV and other retroviruses; integrase  
30 Inhibitors of HIV and other retroviruses; cefaclor (ceclor); acyclovir (zovirax); norfloxacin (noroxin); cefoxitin (mefoxin); cefuroxime axetil (ceftin); ciprofloxacin (cipro); aminacrine hydrochloride; benzethonium chloride : bithionolate sodium; bromchlorenone; carbamide peroxide; cetalkonium chloride; cetylpyridinium chloride :

- 39 -

chlorhexidine hydrochloride; clioquinol; domiphen bromide; fenticlor; fludazonium chloride; fuchsin, basic; furazolidone; gentian violet; halquinols; hexachlorophene : hydrogen peroxide; ichthammol; imidecyl iodine; iodine; isopropyl alcohol; mafenide acetate; meralein sodium; mercufenol chloride; mercury, ammoniated;

5 methylbenzethonium chloride; nitrofurazone; nitromersol; octenidine hydrochloride; oxychlorosene; oxychlorosene sodium; parachlorophenol, camphorated; potassium permanganate; povidone-iodine; sepazonium chloride; silver nitrate; sulfadiazine, silver; symclosene; thimerfonate sodium; thimerosal: troclosene potassium.

Antifungal (antibiotics) include: polyenes such as Amphotericin-B, candicidin,

10 dermostatin, filipin, fungichromin, hachimycin, hamycin, lucensomycin, mepartricin, natamycin, nystatin, pecilocin, perimycin; and others, such as azaserine, griseofulvin, oligomycins, pyrrolnitrin, siccanin, tubercidin and viridin. Antifungal synthetics include: allylamines such as naftifine and terbinafine; imidazoles such as bifonazole, butoconazole, chlordantoin, chlormidazole, cloconazole, clotrimazole, econazole,

15 enilconazole, fenticonazole, isoconazole, ketoconazole, miconazole, omoconazole, oxiconazole nitrate, sulconazole and tioconazole; triazoles such as fluconazole, itraconazole, terconazole. Others include acrisorcin, amorolfine, biphenamine, bromosalicylchloranilide, buclosamide, chlophenesin, ciclopirox, cloxyquin, coparaffinate, diamthazole, dihydrochloride, exalamide, flucytosine, halethazole,

20 hexetidine, loflucarban, nifuratel, potassium iodide, propionates, propionic acid, pyrrithione, salicylanilide, sulbentine, tenonitroazole, tolciolate, tolindate, tolinaftate, tricetin, ujothion, and undecylenic acid. Antifungals also include the echinocandin class class or antifungals, including caspofungin, micafungin, anidulafungin, aminocandin, and the like.

25 Vasoconstrictors include, but are not limited to, epinephrine, norepinephrine, pseudoephedrine, phenylephrine, oxymetazoline, propylhexedrine, naphazoline, tetrahydrolozine, xylometazoline, ethylnorepinephrine, methoxamine, phenylhexedrine, mephentermine, metaraminol, dopamine, dipivefrin, norphedrine and ciraxzoline may be advantageously used in the compositions and methods herein. Use of such should aid in

30 reducing systemic delivery of the active antihyperalgesic agent.

The pharmaceutical preparations of the invention, when used alone or in cocktails, are administered in therapeutically effective amounts. A therapeutically effective amount will be determined by the parameters discussed below; but, in any



- 40 -

event, is that amount which establishes a level of the drug(s) effective for treating a subject, such as a human subject, having one of the conditions described herein. An effective amount means that amount alone or with multiple doses, or the rate of delivery necessary to delay the onset of, lessen the severity of, or inhibit completely, lessen the progression of, or halt altogether the onset or progression of the condition being treated or a symptom associated therewith. In the case of diarrhea, an effective amount can be, for example, that amount which results in one or more of the following : 1) decreasing the frequency of bowel movements; 2) increasing the consistency of the stool, and/or 3) decreasing the stool volume to less than 200 g per day. In one embodiment, an effective amount is an amount that results in 3 or less per bowel movements per day, preferably 2 or less per day, more preferably 1 bowel movement per day. In certain instances, the amount is sufficient to decrease bowel movements within 12 hours of administration of the MNTX, 10 hours, 8 hours, 6 hours, 4 hours, 2 hours, 1 hour and even immediately upon administration, depending upon the mode of administration. Intravenous administration can produce an immediate effect. In restoring gastrointestinal function, an effective amount can be, for example, that amount necessary to increase oral-cecal transit time. For management or treatment of pain, an effective amount can be, for example, that amount to sufficient to make a subject more comfortable as determined by subjective criteria, objective criteria or both. In the case of peripheral hyperalgesia, an effective amount can be, for example, that amount which relieves a symptom of peripheral hyperalgesia such as hypersensitivity to pain or pruritis. For the prevention or treatment of inflammation, an effective amount can be, for example, the amount sufficient to reduce or lessen the redness, swelling, or tissue damage associated with the inflammation or to increase the mobility of an affected area such as a joint. When administered to a subject, effective amounts will depend, of course, on the particular condition being treated; the severity of the condition; individual patient parameters including age, physical condition, size and weight; concurrent treatment; frequency of treatment; and the mode of administration. These factors are well known to those of ordinary skill in the art and can be addressed with no more than routine experimentation.

Generally, oral doses of S-MNTX will be from about 0.05 to about 40 mg/kg, from 0.05 to about 20.0 mg/kg, from about 0.05 to about 10 mg/kg, or from about 0.05 to about 5 mg/kg body weight per day. Generally, parenteral administration, including intravenous and subcutaneous administration, will be from about 0.001 to 1.0 mg/kg,

- 41 -

from about 0.01 to 1.0 mg/kg, or from about 0,1 to 1.0 mg/kg body weight depending on whether administration is as a bolus or is spread out over time such as with an I.V. drip. It is expected that doses ranging from about 0.05 to 0.5 mg/kg body weight will yield the desired results. Dosage may be adjusted appropriately to achieve desired drug levels, local or systemic, depending on the mode of administration. For example, it is expected that the dosage for oral administration of the S-MNTX in an enterically-coated formulation would be lower than in an immediate release oral formulation. In the event that the response in a patient is insufficient at such doses, even higher doses (or effectively higher dosage by a different, more localized delivery route) may be employed to the extent that the patient tolerance permits. Multiple doses per day are contemplated to achieve appropriate systemic levels of compounds. Appropriate systemic levels can be determined by, for example, measurement of the patient's peak or sustained plasma level of the drug. "Dose" and "dosage" are used interchangeably herein.

A variety of administration routes are available. The particular mode selected will depend, of course, upon the particular combination of drugs selected, the severity of the condition being treated, or prevented, the condition of the patient, and the dosage required for therapeutic efficacy. The methods of this invention, generally speaking, may be practiced using any mode of administration that is medically acceptable, meaning any mode that produces effective levels of the active compounds without causing clinically unacceptable adverse effects. Such modes of administration include oral, rectal, topical, transdermal, sublingual, intravenous infusion, pulmonary, intra-arterial, intra-adipose tissue, intra-lymphatic, intramuscular, intracavity, aerosol, aural (e.g., via eardrops), intranasal, inhalation, intra-articular, needleless injection, subcutaneous or intradermal (e.g., transdermal) delivery. For continuous infusion, a patient-controlled analgesia (PCA) device or an implantable drug delivery device may be employed. Oral, rectal, or topical administration may be important for prophylactic or long-term treatment. Preferred rectal modes of delivery include administration as a suppository or enema wash.

The pharmaceutical preparations may conveniently be presented in unit dosage form and may be prepared by any of the methods well known in the art of pharmacy. All methods include the step of bringing the compounds of the invention into association with a carrier which constitutes one or more accessory ingredients. In general, the compositions are prepared by uniformly and intimately bringing the compounds of the

- 42 -

invention into association with a liquid carrier, a finely divided solid carrier, or both, and then, if necessary, shaping the product.

When administered, the pharmaceutical preparations of the invention are applied in pharmaceutically acceptable compositions. Such preparations may routinely contain salts, buffering agents, preservatives, compatible carriers, lubricants, and optionally other therapeutic ingredients. When used in medicine the salts should be pharmaceutically acceptable, but non-pharmaceutically acceptable salts may conveniently be used to prepare pharmaceutically acceptable salts thereof and are not excluded from the scope of the invention. Such pharmacologically and pharmaceutically acceptable salts include, but are not limited to, those prepared from the following acids: hydrochloric, hydrobromic, sulfuric, nitric, phosphoric, maleic, acetic, salicylic, p-toluenesulfonic, tartaric, citric, methanesulfonic, formic, succinic, naphthalene-2-sulfonic, pamoic, 3-hydroxy-2-naphthalenecarboxylic, and benzene sulfonic.

It should be understood that when referring to MNTX, R- and S-MNTX, and therapeutic agent(s) of the invention, it is meant to encompass salts of the same. Such salts are of a variety well known to those of ordinary skill in the art. When used in pharmaceutical preparations, the salts preferably are pharmaceutically-acceptable for use in humans. Bromide is an example of one such salt.

The pharmaceutical preparations of the present invention may include or be diluted into a pharmaceutically-acceptable carrier. The term "pharmaceutically-acceptable carrier" as used herein means one or more compatible solid or liquid fillers, diluents or encapsulating substances which are suitable for administration to a human or other mammal such as non-human primate, a dog, cat, horse, cow, sheep, pig, or goat. The term "carrier" denotes an organic or inorganic ingredient, natural or synthetic, with which the active ingredient is combined to facilitate the application. The carriers are capable of being commingled with the preparations of the present invention, and with each other, in a manner such that there is no interaction which would substantially impair the desired pharmaceutical efficacy or stability. Carrier formulations suitable for oral administration, for suppositories, and for parenteral administration, etc., can be found in Remington's Pharmaceutical Sciences, Mack Publishing Company, Easton, Pa.

Aqueous formulations may include a chelating agent, a buffering agent, an antioxidant and, optionally, an isotonicity agent, preferably pH adjusted to between 3.0 and 3.5. Examples of such formulations that are stable to autoclaving and long term storage

- 43 -

are described in co-pending U.S. Application Serial No. 10/821,811, entitled "Pharmaceutical Formulation."

Chelating agents include, for example, ethylenediaminetetraacetic acid (EDTA) and derivatives thereof, citric acid and derivatives thereof, niacinamide and derivatives thereof, sodium desoxycholate and derivatives thereof, and L-glutamic acid, N, N-diacetic acid and derivatives thereof.

Buffering agents include those selected from the group consisting of citric acid, sodium citrate, sodium acetate, acetic acid, sodium phosphate and phosphoric acid, sodium ascorbate, tartaric acid, maleic acid, glycine, sodium lactate, lactic acid, ascorbic acid, imidazole, sodium bicarbonate and carbonic acid, sodium succinate and succinic acid, histidine, and sodium benzoate and benzoic acid, or combinations thereof.

Antioxidants include those selected from the group consisting of an ascorbic acid derivative, butylated hydroxy anisole, butylated hydroxy toluene, alkyl gallate, sodium meta-bisulfite, sodium bisulfite, sodium dithionite, sodium thioglycollate acid, sodium formaldehyde sulfoxylate, tocopheral and derivatives thereof, monothioglycerol, and sodium sulfite. The preferred antioxidant is monothioglycerol.

Isotonicity agents include those selected from the group consisting of sodium chloride, mannitol, lactose, dextrose, glycerol, and sorbitol.

Preservatives that can be used with the present compositions include benzyl alcohol, parabens, thimerosal, chlorobutanol and preferably benzalkonium chloride. Typically, the preservative will be present in a composition in a concentration of up to about 2% by weight. The exact concentration of the preservative, however, will vary depending upon the intended use and can be easily ascertained by one skilled in the art.

The compounds of the invention can be prepared in lyophilized compositions, preferably in the presence of a cryoprotecting agent such as mannitol, or lactose, sucrose, polyethylene glycol, and polyvinyl pyrrolidines. Cryoprotecting agents which result in a reconstitution pH of 6.0 or less are preferred. The invention therefore provides a lyophilized preparation of therapeutic agent(s) of the invention. The preparation can contain a cryoprotecting agent, such as mannitol or lactose, which is preferably neutral or acidic in water.

Oral, parenteral and suppository formulations of agents are well known and commercially available. The therapeutic agent(s) of the invention can be added to such well known formulations. It can be mixed together in solution or semi-solid solution in

- 44 -

such formulations, can be provided in a suspension within such formulations or could be contained in particles within such formulations.

A product containing therapeutic agent(s) of the invention and, optionally, one or more other active agents can be configured as an oral dosage. The oral dosage may be a liquid, a semisolid or a solid. An opioid may optionally be included in the oral dosage. The oral dosage may be configured to release the therapeutic agent(s) of the invention before, after or simultaneously with the other agent (and/or the opioid). The oral dosage may be configured to have the therapeutic agent(s) of the invention and the other agents release completely in the stomach, release partially in the stomach and partially in the intestine, in the intestine, in the colon, partially in the stomach, or wholly in the colon. The oral dosage also may be configured whereby the release of the therapeutic agent(s) of the invention is confined to the stomach or intestine while the release of the other active agent is not so confined or is confined differently from the therapeutic agent(s) of the invention. For example, the therapeutic agent(s) of the invention may be an enterically coated core or pellets contained within a pill or capsule that releases the other agent first and releases the therapeutic agent(s) of the invention only after the therapeutic agent(s) of the invention passes through the stomach and into the intestine. The therapeutic agent(s) of the invention also can be in a sustained release material, whereby the therapeutic agent(s) of the invention is released throughout the gastrointestinal tract and the other agent is released on the same or a different schedule. The same objective for therapeutic agent(s) of the invention release can be achieved with immediate release of therapeutic agent(s) of the invention combined with enteric coated therapeutic agent(s) of the invention. In these instances, the other agent could be released immediately in the stomach, throughout the gastrointestinal tract or only in the intestine.

The materials useful for achieving these different release profiles are well known to those of ordinary skill in the art. Immediate release is obtainable by conventional tablets with binders which dissolve in the stomach. Coatings which dissolve at the pH of the stomach or which dissolve at elevated temperatures will achieve the same purpose. Release only in the intestine is achieved using conventional enteric coatings such as pH sensitive coatings which dissolve in the pH environment of the intestine (but not the stomach) or coatings which dissolve over time. Release throughout the gastrointestinal tract is achieved by using sustained-release materials and/or combinations of the

- 45 -

immediate release systems and sustained and/or delayed intentional release systems (e.g., pellets which dissolve at different pHs).

In the event that it is desirable to release the therapeutic agent(s) of the invention first, the therapeutic agent(s) of the invention could be coated on the surface of the controlled release formulation in any pharmaceutically acceptable carrier suitable for such coatings and for permitting the release of the therapeutic agent(s) of the invention, such as in a temperature sensitive pharmaceutically acceptable carrier used for controlled release routinely. Other coatings which dissolve when placed in the body are well known to those of ordinary skill in the art.

The therapeutic agent(s) of the invention also may be mixed throughout a controlled release formulation, whereby it is released before, after or simultaneously with another agent. The therapeutic agent(s) of the invention may be free, that is, solubilized within the material of the formulation. The therapeutic agent(s) of the invention also may be in the form of vesicles, such as wax coated micropellets dispersed throughout the material of the formulation. The coated pellets can be fashioned to immediately release the therapeutic agent(s) of the invention based on temperature, pH or the like. The pellets also can be configured so as to delay the release of the therapeutic agent(s) of the invention, allowing the other agent a period of time to act before the therapeutic agent(s) of the invention exerts its effects. The therapeutic agent(s) of the invention pellets also can be configured to release the therapeutic agent(s) of the invention in virtually any sustained release pattern, including patterns exhibiting first order release kinetics or sigmoidal order release kinetics using materials of the prior art and well known to those of ordinary skill in the art.

The therapeutic agent(s) of the invention also can be contained within a core within the controlled release formulation. The core may have any one or any combination of the properties described above in connection with the pellets. The therapeutic agent(s) of the invention may be, for example, in a core coated with a material, dispersed throughout a material, coated onto a material or adsorbed into or throughout a material.

It should be understood that the pellets or core may be of virtually any type. They may be drug coated with a release material, drug interspersed throughout material, drug adsorbed into a material, and so on. The material may be erodible or nonerodible.

- 46 -

The therapeutic agent(s) of the invention, may be provided in particles. Particles as used herein means nano or microparticles (or in some instances larger) which can consist in whole or in part of the therapeutic agent(s) of the inventions or the other agents as described herein. The particles may contain the therapeutic agent(s) in a core surrounded by a coating, including, but not limited to, an enteric coating. The therapeutic agent(s) also may be dispersed throughout the particles. The therapeutic agent(s) also may be adsorbed into the particles. The particles may be of any order release kinetics, including zero order release, first order release, second order release, delayed release, sustained release, immediate release, and any combination thereof, etc. The particle may include, in addition to the therapeutic agent(s), any of those materials routinely used in the art of pharmacy and medicine, including, but not limited to, erodible, nonerodible, biodegradable, or nonbiodegradable material or combinations thereof. The particles may be microcapsules which contain the antagonist in a solution or in a semi-solid state. The particles may be of virtually any shape.

Both non-biodegradable and biodegradable polymeric materials can be used in the manufacture of particles for delivering the therapeutic agent(s). Such polymers may be natural or synthetic polymers. The polymer is selected based on the period of time over which release is desired. Bioadhesive polymers of particular interest include bioerodible hydrogels described by H.S. Sawhney, C.P. Pathak and J.A. Hubell in *Macromolecules*, (1993) 26:581-587, the teachings of which are incorporated herein. These include polyhyaluronic acids, casein, gelatin, gluten, polyanhydrides, polyacrylic acid, alginate, chitosan, poly(methyl methacrylates), poly(ethyl methacrylates), poly(butylmethacrylate), poly(isobutyl methacrylate), poly(hexylmethacrylate), poly(isodecyl methacrylate), poly(lauryl methacrylate), poly(phenyl methacrylate), poly(methyl acrylate), poly(isopropyl acrylate), poly(isobutyl acrylate), and poly(octadecyl acrylate).

The therapeutic agent(s) may be contained in controlled release systems. The term "controlled release" is intended to refer to any drug-containing formulation in which the manner and profile of drug release from the formulation are controlled. This refers to immediate as well as nonimmediate release formulations, with nonimmediate release formulations including but not limited to sustained release and delayed release formulations. The term "sustained release" (also referred to as "extended release") is used in its conventional sense to refer to a drug formulation that provides for gradual

- 47 -

release of a drug over an extended period of time, and that preferably, although not necessarily, results in substantially constant blood levels of a drug over an extended time period. The term "delayed release" is used in its conventional sense to refer to a drug formulation in which there is a time delay between administration of the formulation and the release of the drug therefrom. "Delayed release" may or may not involve gradual  
5 release of drug over an extended period of time, and thus may or may not be "sustained release." These formulations may be for any mode of administration.

Delivery systems specific for the gastrointestinal tract are roughly divided into three types: the first is a delayed release system designed to release a drug in response to, for example, a change in pH; the second is a timed-release system designed to release a  
10 drug after a predetermined time; and the third is a microflora enzyme system making use of the abundant enterobacteria in the lower part of the gastrointestinal tract (e.g., in a colonic site-directed release formulation).

An example of a delayed release system is one that uses, for example, an acrylic or cellulosic coating material and dissolves on pH change. Because of ease of  
15 preparation, many reports on such "enteric coatings" have been made. In general, an enteric coating is one which passes through the stomach without releasing substantial amounts of drug in the stomach (i.e., less than 10% release, 5% release and even 1% release in the stomach) and sufficiently disintegrating in the intestinal tract (by contact  
20 with approximately neutral or alkaline intestine juices) to allow the transport (active or passive) of the active agent through the walls of the intestinal tract.

Various *in vitro* tests for determining whether or not a coating is classified as an enteric coating have been published in the pharmacopoeia of various countries. A coating which remains intact for at least 2 hours, in contact with artificial gastric juices  
25 such as HCl of pH 1 at 36 to 38 °C and thereafter disintegrates within 30 minutes in artificial intestinal juices such as a KH<sub>2</sub>PO<sub>4</sub> buffered solution of pH 6.8 is one example. One such well known system is EUDRAGIT material, commercially available and reported on by Behringer, Manchester University, Saale Co., and the like. Enteric coatings are discussed further, below.

30 A timed release system is represented by Time Erosion System (TES) by Fujisawa Pharmaceutical Co., Ltd. and Pulsincap by R. P. Scherer. According to these systems, the site of drug release is decided by the time of transit of a preparation in the gastrointestinal tract. Since the transit of a preparation in the gastrointestinal tract is



- 48 -

largely influenced by the gastric emptying time, some time release systems are also enterically coated.

Systems making use of the enterobacteria can be classified into those utilizing degradation of azoaromatic polymers by an azo reductase produced from enterobacteria as reported by the group of Ohio University (M. Saffran, et al., Science, Vol. 233: 1081 (1986)) and the group of Utah University (J. Kopecek, et al., Pharmaceutical Research, 9(12), 1540-1545 (1992)); and those utilizing degradation of polysaccharides by beta-galactosidase of enterobacteria as reported by the group of Hebrew University (unexamined published Japanese patent application No. 5-50863 based on a PCT application) and the group of Freiberg University (K. H. Bauer et al., Pharmaceutical Research, 10(10), S218 (1993)). In addition, the system using chitosan degradable by chitosanase by Teikoku Seiyaku K. K. (unexamined published Japanese patent application No. 4-217924 and unexamined published Japanese patent application No. 4-225922) is also included.

The enteric coating is typically, although not necessarily, a polymeric material. Preferred enteric coating materials comprise bioerodible, gradually hydrolyzable and/or gradually water-soluble polymers. The "coating weight," or relative amount of coating material per capsule, generally dictates the time interval between ingestion and drug release. Any coating should be applied to a sufficient thickness such that the entire coating does not dissolve in the gastrointestinal fluids at pH below about 5, but does dissolve at pH about 5 and above. It is expected that any anionic polymer exhibiting a pH-dependent solubility profile can be used as an enteric coating in the practice of the present invention. The selection of the specific enteric coating material will depend on the following properties: resistance to dissolution and disintegration in the stomach; impermeability to gastric fluids and drug/carrier/enzyme while in the stomach; ability to dissolve or disintegrate rapidly at the target intestine site; physical and chemical stability during storage; non-toxicity; ease of application as a coating (substrate friendly); and economical practicality.

Suitable enteric coating materials include, but are not limited to: cellulosic polymers such as cellulose acetate phthalate, cellulose acetate trimellitate, hydroxypropylmethyl cellulose phthalate, hydroxypropylmethyl cellulose succinate and carboxymethylcellulose sodium; acrylic acid polymers and copolymers, preferably formed from acrylic acid, methacrylic acid, methyl acrylate, ammonium methacrylate,

- 49 -

ethyl acrylate, methyl methacrylate and/or ethyl methacrylate (e.g., those copolymers sold under the trade name EUDRAGIT); vinyl polymers and copolymers such as polyvinyl acetate, polyvinylacetate phthalate, vinylacetate crotonic acid copolymer, and ethylene-vinyl acetate copolymers; and shellac (purified lac). Combinations of different coating materials may also be used. Well known enteric coating material for use herein are those acrylic acid polymers and copolymers available under the trade name EUDRAGIT from Rohm Pharma (Germany). The EUDRAGIT series E, L, S, RL, RS and NE copolymers are available as solubilized in organic solvent, as an aqueous dispersion, or as a dry powder. The EUDRAGIT series RL, NE, and RS copolymers are insoluble in the gastrointestinal tract but are permeable and are used primarily for extended release. The EUDRAGIT series E copolymers dissolve in the stomach. The EUDRAGIT series L, L-30D and S copolymers are insoluble in stomach and dissolve in the intestine, and are thus most preferred herein.

A particular methacrylic copolymer is EUDRAGIT L, particularly L-30D and EUDRAGIT L 100-55. In EUDRAGIT L-30D, the ratio of free carboxyl groups to ester groups is approximately 1:1. Further, the copolymer is known to be insoluble in gastrointestinal fluids having pH below 5.5, generally 1.5-5.5, i.e., the pH generally present in the fluid of the upper gastrointestinal tract, but readily soluble or partially soluble at pH above 5.5, i.e., the pH generally present in the fluid of lower gastrointestinal tract. Another particular methacrylic acid polymer is EUDRAGIT S, which differs from EUDRAGIT L-30D in that the ratio of free carboxyl groups to ester groups is approximately 1:2. EUDRAGIT S is insoluble at pH below 5.5, but unlike EUDRAGIT L-30D, is poorly soluble in gastrointestinal fluids having a pH in the range of 5.5 to 7.0, such as in the small intestine. This copolymer is soluble at pH 7.0 and above, i.e., the pH generally found in the colon. EUDRAGIT S can be used alone as a coating to provide drug delivery in the large intestine. Alternatively, EUDRAGIT S, being poorly soluble in intestinal fluids below pH 7, can be used in combination with EUDRAGIT L-30D, soluble in intestinal fluids above pH 5.5, in order to provide a delayed release composition which can be formulated to deliver the active agent to various segments of the intestinal tract. The more EUDRAGIT L-30D used, the more proximal release and delivery begins, and the more EUDRAGIT S used, the more distal release and delivery begins. It will be appreciated by those skilled in the art that both EUDRAGIT L-30D and EUDRAGIT S can be replaced with other pharmaceutically

- 50 -

acceptable polymers having similar pH solubility characteristics. In certain embodiments of the invention, the preferred enteric coating is ACRYL-EZE™ (methacrylic acid co-polymer type C; Colorcon, West Point, PA).

The enteric coating provides for controlled release of the active agent, such that drug release can be accomplished at some generally predictable location. The enteric coating also prevents exposure of the therapeutic agent and carrier to the epithelial and mucosal tissue of the buccal cavity, pharynx, esophagus, and stomach, and to the enzymes associated with these tissues. The enteric coating therefore helps to protect the active agent, carrier and a patient's internal tissue from any adverse event prior to drug release at the desired site of delivery. Furthermore, the coated material of the present invention allows optimization of drug absorption, active agent protection, and safety. Multiple enteric coatings targeted to release the active agent at various regions in the gastrointestinal tract would enable even more effective and sustained improved delivery throughout the gastrointestinal tract.

The coating can, and usually does, contain a plasticizer to prevent the formation of pores and cracks that would permit the penetration of the gastric fluids. Suitable plasticizers include, but are not limited to, triethyl citrate (Citroflex 2), triacetin (glyceryl triacetate), acetyl triethyl citrate (Citroflex A2), Carbowax 400 (polyethylene glycol 400), diethyl phthalate, tributyl citrate, acetylated monoglycerides, glycerol, fatty acid esters, propylene glycol, and dibutyl phthalate. In particular, a coating comprised of an anionic carboxylic acrylic polymer will usually contain approximately 10% to 25% by weight of a plasticizer, particularly dibutyl phthalate, polyethylene glycol, triethyl citrate and triacetin. The coating can also contain other coating excipients such as detackifiers, antifoaming agents, lubricants (e.g., magnesium stearate), and stabilizers (e.g., hydroxypropylcellulose, acids and bases) to solubilize or disperse the coating material, and to improve coating performance and the coated product.

The coating can be applied to particles of the therapeutic agent(s), tablets of the therapeutic agent(s), capsules containing the therapeutic agent(s) and the like, using conventional coating methods and equipment. For example, an enteric coating can be applied to a capsule using a coating pan, an airless spray technique, fluidized bed coating equipment, or the like. Detailed information concerning materials, equipment and processes for preparing coated dosage forms may be found in *Pharmaceutical Dosage Forms: Tablets*, eds. Lieberman et al. (New York: Marcel Dekker, Inc., 1989), and in

Ansel et al., *Pharmaceutical Dosage Forms and Drug Delivery Systems*, 6th Ed. (Media, PA: Williams & Wilkins, 1995). The coating thickness, as noted above, must be sufficient to ensure that the oral dosage form remains intact until the desired site of topical delivery in the lower intestinal tract is reached.

5 In another embodiment, drug dosage forms are provided that comprise an enterically coated, osmotically activated device housing a formulation of the invention. In this embodiment, the drug-containing formulation is encapsulated in a semipermeable membrane or barrier containing a small orifice. As known in the art with respect to so-called "osmotic pump" drug delivery devices, the semipermeable membrane allows  
10 passage of water in either direction, but not drug. Therefore, when the device is exposed to aqueous fluids, water will flow into the device due to the osmotic pressure differential between the interior and exterior of the device. As water flows into the device, the drug-containing formulation in the interior will be "pumped" out through the orifice. The rate of drug release will be equivalent to the inflow rate of water times the drug  
15 concentration. The rate of water influx and drug efflux can be controlled by the composition and size of the orifice of the device. Suitable materials for the semipermeable membrane include, but are not limited to, polyvinyl alcohol, polyvinyl chloride, semipermeable polyethylene glycols, semipermeable polyurethanes, semipermeable polyamides, semipermeable sulfonated polystyrenes and polystyrene  
20 derivatives; semipermeable poly(sodium styrenesulfonate), semipermeable poly(vinylbenzyltrimethylammonium chloride), and cellulosic polymers such as cellulose acetate, cellulose diacetate, cellulose triacetate, cellulose propionate, cellulose acetate propionate, cellulose acetate butyrate, cellulose trivalerate, cellulose trilimate, cellulose tripalmitate, cellulose trioctanoate, cellulose tripropionate, cellulose  
25 disuccinate, cellulose dipalmitate, cellulose dicylate, cellulose acetate succinate, cellulose propionate succinate, cellulose acetate octanoate, cellulose valerate palmitate, cellulose acetate heptanate, cellulose acetaldehyde dimethyl acetal, cellulose acetate ethylcarbamate, cellulose acetate methylcarbamate, cellulose dimethylaminoacetate and ethylcellulose.

30 In another embodiment, drug dosage forms are provided that comprise a sustained release coated device housing a formulation of the invention. In this embodiment, the drug-containing formulation is encapsulated in a sustained release membrane or film. The membrane may be semipermeable, as described above. A

- 52 -

semipermeable membrane allows for the passage of water inside the coated device to dissolve the drug. The dissolved drug solution diffuses out through the semipermeable membrane. The rate of drug release depends upon the thickness of the coated film and the release of drug can begin in any part of the GI tract. Suitable membrane materials for  
5 such a membrane include ethylcellulose.

In another embodiment, drug dosage forms are provided that comprise a sustained release device housing a formulation of the invention. In this embodiment, the drug-containing formulation is uniformly mixed with a sustained release polymer. These sustained release polymers are high molecular weight water-soluble polymers, which  
10 when in contact with water, swell and create channels for water to diffuse inside and dissolve the drug. As the polymers swell and dissolve in water, more of drug is exposed to water for dissolution. Such a system is generally referred to as sustained release matrix. Suitable materials for such a device include hydropropyl methylcellulose, hydroxypropyl cellulose, hydroxyethyl cellulose and methyl cellulose.

In another embodiment, drug dosage forms are provided that comprise an enteric  
15 coated device housing a sustained release formulation of the invention. In this embodiment, the drug containing product described above is coated with an enteric polymer. Such a device would not release any drug in the stomach and when the device reaches the intestine, the enteric polymer is first dissolved and only then would the drug  
20 release begin. The drug release would take place in a sustained release fashion.

Enterically coated, osmotically activated devices can be manufactured using conventional materials, methods and equipment. For example, osmotically activated devices may be made by first encapsulating, in a pharmaceutically acceptable soft capsule, a liquid or semi-solid formulation of the compounds of the invention as  
25 described previously. This interior capsule is then coated with a semipermeable membrane composition (comprising, for example, cellulose acetate and polyethylene glycol 4000 in a suitable solvent such as a methylene chloride-methanol admixture), for example using an air suspension machine, until a sufficiently thick laminate is formed, e.g., around 0.05 mm. The semipermeable laminated capsule is then dried using  
30 conventional techniques. Then, an orifice having a desired diameter (e.g., about 0.99 mm) is provided through the semipermeable laminated capsule wall, using, for example, mechanical drilling, laser drilling, mechanical rupturing, or erosion of an erodible element such as a gelatin plug. The osmotically activated device may then be enterically

- 53 -

coated as previously described. For osmotically activated devices containing a solid carrier rather than a liquid or semi-solid carrier, the interior capsule is optional; that is, the semipermeable membrane may be formed directly around the carrier-drug composition. However, preferred carriers for use in the drug-containing formulation of the osmotically activated device are solutions, suspensions, liquids, immiscible liquids, emulsions, sols, colloids, and oils. Particularly preferred carriers include, but are not limited to, those used for enterically coated capsules containing liquid or semisolid drug formulations.

Cellulose coatings include those of cellulose acetate phthalate and trimellitate; methacrylic acid copolymers, e.g. copolymers derived from methylacrylic acid and esters thereof, containing at least 40% methylacrylic acid; and especially hydroxypropyl methylcellulose phthalate. Methacrylates include those of molecular weight above 100,000 daltons based on, e.g. methylacrylate and methyl or ethyl methylacrylate in a ratio of about 1:1. Typical products include Endragit L, e.g. L 100-55, marketed by Rohm GmbH, Darmstadt, Germany. Typical cellulose acetate phthalates have an acetyl content of 17-26% and a phthalate content of from 30-40% with a viscosity of ca. 45-90 cP. Typical cellulose acetate trimellitites have an acetyl content of 17-26%, a trimellityl content from 25-35% with a viscosity of ca. 15-20 cS. An example of a cellulose acetate trimellitate is the marketed product CAT (Eastman Kodak Company, USA). Hydroxypropyl methylcellulose phthalates typically have a molecular weight of from 20,000 to 130,000 daltons, a hydroxypropyl content of from 5 to 10%, a methoxy content of from 18 to 24% and a phthalyl content from 21 to 35%. An example of a cellulose acetate phthalate is the marketed product CAP (Eastman Kodak, Rochester N.Y., USA). Examples of hydroxypropyl methylcellulose phthalates are the marketed products having a hydroxypropyl content of from 6-10%, a methoxy content of from 20-24%, a phthalyl content of from 21-27%, a molecular weight of about 84,000 daltons, sold under the trademark HP50 and available from Shin-Etsu Chemical Co. Ltd., Tokyo, Japan, and having a hydroxypropyl content, a methoxyl content, and a phthalyl content of 5-9%, 18-22% and 27-35%, respectively, and a molecular weight of 78,000 daltons, known under the trademark HP55 and available from the same supplier.

The therapeutic agents may be provided in capsules, coated or not. The capsule material may be either hard or soft, and as will be appreciated by those skilled in the art, typically comprises a tasteless, easily administered and water soluble compound such as

- 54 -

gelatin, starch or a cellulosic material. The capsules are preferably sealed, such as with gelatin bands or the like. See, for example, Remington: The Science and Practice of Pharmacy, Nineteenth Edition (Easton, Pa.: Mack Publishing Co., 1995), which describes materials and methods for preparing encapsulated pharmaceuticals.

5 A product containing therapeutic agent(s) of the invention can be configured as a suppository. The therapeutic agent(s) of the invention can be placed anywhere within or on the suppository to favorably affect the relative release of the therapeutic agent(s). The nature of the release can be zero order, first order, or sigmoidal, as desired.

Suppositories are solid dosage forms of medicine intended for administration via  
10 the rectum. Suppositories are compounded so as to melt, soften, or dissolve in the body cavity (around 98.6 °F) thereby releasing the medication contained therein. Suppository bases should be stable, nonirritating, chemically inert, and physiologically inert. Many commercially available suppositories contain oily or fatty base materials, such as cocoa butter, coconut oil, palm kernel oil, and palm oil, which often melt or deform at room  
15 temperature necessitating cool storage or other storage limitations. U.S. Patent No. 4,837,214 to Tanaka et al. describes a suppository base comprised of 80 to 99 percent by weight of a lauric-type fat having a hydroxyl value of 20 or smaller and containing glycerides of fatty acids having 8 to 18 carbon atoms combined with 1 to 20 percent by weight diglycerides of fatty acids (which erucic acid is an example of). The shelf life of  
20 these type of suppositories is limited due to degradation. Other suppository bases contain alcohols, surfactants, and the like which raise the melting temperature but also can lead to poor absorption of the medicine and side effects due to irritation of the local mucous membranes (see for example, U.S. Patent No. 6,099,853 to Hartelendy et al., U.S. Patent No. 4,999,342 to Ahmad et al., and U.S. Patent No. 4,765,978 to Abidi et al.).  
25

The base used in the pharmaceutical suppository composition of this invention includes, in general, oils and fats comprising triglycerides as main components such as cacao butter, palm fat, palm kernel oil, coconut oil, fractionated coconut oil, lard and WITEPSOL®, waxes such as lanolin and reduced lanolin; hydrocarbons such as  
30 VASELINE®, squalene, squalane and liquid paraffin; long to medium chain fatty acids such as caprylic acid, lauric acid, stearic acid and oleic acid; higher alcohols such as lauryl alcohol, cetanol and stearyl alcohol; fatty acid esters such as butyl stearate and dilauryl malonate; medium to long chain carboxylic acid esters of glycerin such as

- 55 -

triolein and tristearin; glycerin-substituted carboxylic acid esters such as glycerin acetoacetate; and polyethylene glycols and its derivatives such as macrogols and cetomacrogol. They may be used either singly or in combination of two or more. If desired, the composition of this invention may further include a surface-active agent, a coloring agent, etc., which are ordinarily used in suppositories.

The pharmaceutical composition of this invention may be prepared by uniformly mixing predetermined amounts of the active ingredient, the absorption aid and optionally the base, etc. in a stirrer or a grinding mill, if required at an elevated temperature. The resulting composition, may be formed into a suppository in unit dosage form by, for example, casting the mixture in a mold, or by forming it into a gelatin capsule using a capsule filling machine.

The compositions according to the present invention also can be administered as a nasal spray, nasal drop, suspension, gel, ointment, cream or powder. The administration of a composition can also include using a nasal tampon or a nasal sponge containing a composition of the present invention.

The nasal delivery systems that can be used with the present invention can take various forms including aqueous preparations, non-aqueous preparations and combinations thereof. Aqueous preparations include, for example, aqueous gels, aqueous suspensions, aqueous liposomal dispersions, aqueous emulsions, aqueous microemulsions and combinations thereof. Non-aqueous preparations include, for example, non-aqueous gels, non-aqueous suspensions, non-aqueous liposomal dispersions, non-aqueous emulsions, non-aqueous microemulsions and combinations thereof. The various forms of the nasal delivery systems can include a buffer to maintain pH, a pharmaceutically acceptable thickening agent and a humectant. The pH of the buffer can be selected to optimize the absorption of the therapeutic agent(s) across the nasal mucosa.

With respect to the non-aqueous nasal formulations, suitable forms of buffering agents can be selected such that when the formulation is delivered into the nasal cavity of a mammal, selected pH ranges are achieved therein upon contact with, e.g., a nasal mucosa. In the present invention, the pH of the compositions should be maintained from about 2.0 to about 6.0. It is desirable that the pH of the compositions is one which does not cause significant irritation to the nasal mucosa of a recipient upon administration.



- 56 -

The viscosity of the compositions of the present invention can be maintained at a desired level using a pharmaceutically acceptable thickening agent. Thickening agents that can be used in accordance with the present invention include methyl cellulose, xanthan gum, carboxymethyl cellulose, hydroxypropyl cellulose, carbomer, polyvinyl alcohol, alginates, acacia, chitosans and combinations thereof. The concentration of the thickening agent will depend upon the agent selected and the viscosity desired. Such agents can also be used in a powder formulation discussed above.

The compositions of the present invention can also include a humectant to reduce or prevent drying of the mucus membrane and to prevent irritation thereof. Suitable humectants that can be used in the present invention include sorbitol, mineral oil, vegetable oil and glycerol; soothing agents; membrane conditioners; sweeteners; and combinations thereof. The concentration of the humectant in the present compositions will vary depending upon the agent selected.

One or more therapeutic agents may be incorporated into the nasal delivery system or any other delivery system described herein.

A composition formulated for topical administration may be liquid or semi-solid (including, for example, a gel, lotion, emulsion, cream, ointment, spray or aerosol) or may be provided in combination with a "finite" carrier, for example, a non-spreading material that retains its form, including, for example, a patch, bioadhesive, dressing or bandage. It may be aqueous or non-aqueous; it may be formulated as a solution, emulsion, dispersion, a suspension or any other mixture.

Important modes of administration include topical application to the skin, eyes or mucosa. Thus, typical vehicles are those suitable for pharmaceutical or cosmetic application to body surfaces. The compositions provided herein may be applied topically or locally to various areas in the body of a patient. As noted above, topical application is intended to refer to application to the tissue of an accessible body surface, such as, for example, the skin (the outer integument or covering) and the mucosa (the mucous-producing, secreting and/or containing surfaces). Exemplary mucosal surfaces include the mucosal surfaces of the eyes, mouth (such as the lips, tongue, gums, cheeks, sublingual and roof of the mouth), larynx, esophagus, bronchial, nasal passages, vagina and rectum/anus; in some embodiments, preferably the mouth, larynx, esophagus, vagina and rectum/anus; in other embodiments, preferably the eyes, larynx, esophagus, bronchial, nasal passages, and vagina and rectum/anus. As noted above, local application

- 57 -

herein refers to application to a discrete internal area of the body, such as, for example, a joint, soft tissue area (such as muscle, tendon, ligaments, intraocular or other fleshy internal areas), or other internal area of the body. Thus, as used herein, local application refers to applications to discrete areas of the body.

5           With respect to topical and/or local administration of the present compositions, desirable efficacy may involve, for example, penetration of therapeutic agent(s) of the invention into the skin and/or tissue to substantially reach a hyperalgesic site to provide desirable anti-hyperalgesic pain relief. The efficacy of the present compositions may be about the same as that achieved, for example, with central opiate analgesics. But, as  
10       discussed in detail herein, the efficacy achieved with therapeutic agent(s) of the invention is preferably obtained without the undesirable effects that are typically associated with central opiates including, for example, respiratory depression, sedation, and addiction, as it is believed that therapeutic agent(s) of the invention does not cross  
15       the blood brain barrier.

15           Also in certain preferred embodiments, including embodiments that involve aqueous vehicles, the compositions may also contain a glycol, that is, a compound containing two or more hydroxy groups. A glycol which is particularly preferred for use in the compositions is propylene glycol. In these preferred embodiments, the glycol is preferably included in the compositions in a concentration of from greater than 0 to about  
20       5 wt. %, based on the total weight of the composition. More preferably, the compositions contain from about 0.1 to less than about 5 wt. % of a glycol, with from about 0.5 to about 2 wt. % being even more preferred. Still more preferably, the compositions contain about 1 wt. % of a glycol.

25           For local internal administration, such as intra-articular administration, the compositions are preferably formulated as a solution or a suspension in an aqueous-based medium, such as isotonic buffered saline or are combined with a biocompatible support or bioadhesive intended for internal administration.

30           Lotions, which, for example, may be in the form of a suspension, dispersion or emulsion, contain an effective concentration of one or more of the compounds. The effective concentration is preferably to deliver an effective amount, typically at a concentration of between about 0.1-50% [by weight] or more of one or more of the compounds provided herein. The lotions also contain [by weight] from 1% to 50% of an emollient and the balance water, a suitable buffer, and other agents as described above.

- 58 -

Any emollients known to those of skill in the art as suitable for application to human skin may be used. These include, but are not limited to, the following: (a) Hydrocarbon oils and waxes, including mineral oil, petrolatum, paraffin, ceresin, ozokerite, microcrystalline wax, polyethylene, and perhydrosqualene. b) Silicone oils, including dimethylpolysiloxanes, methylphenylpolysiloxanes, water-soluble and alcohol-soluble silicone-glycol copolymers. (c) Triglyceride fats and oils, including those derived from vegetable, animal and marine sources. Examples include, but are not limited to, castor oil, safflower oil, cotton seed oil, corn oil, olive oil, cod liver oil, almond oil, avocado oil, palm oil, sesame oil, and soybean oil. (d) Acetoglyceride esters, such as acetylated monoglycerides. (e) Ethoxylated glycerides, such as ethoxylated glyceryl monstearate. (f) Alkyl esters of fatty acids having 10 to 20 carbon atoms. Methyl, isopropyl and butyl esters of fatty acids are useful herein. Examples include, but are not limited to, hexyl laurate, isohexyl laurate, isohexyl palmitate, isopropyl palmitate, isopropyl myristate, decyl oleate, isodecyl oleate, hexadecyl stearate, decyl stearate, isopropyl isostearate, diisopropyl adipate, diisohexyl adipate, dihexyldecyl adipate, diisopropyl sebacate, lauryl lactate, myristyl lactate, and cetyl lactate. (g) Alkenyl esters of fatty acids having 10 to 20 carbon atoms. Examples thereof include, but are not limited to, oleyl myristate, oleyl stearate, and oleyl oleate. (h) Fatty acids having 9 to 22 carbon atoms. Suitable examples include, but are not limited to, pelargonic, lauric, myristic, palmitic, stearic, isostearic, hydroxystearic, oleic, linoleic, ricinoleic, arachidonic, behenic, and erucic acids. (i) Fatty alcohols having 10 to 22 carbon atoms, such as, but not limited to, lauryl, myristyl, cetyl, hexadecyl, stearyl, isostearyl, hydroxystearyl, oleyl, ricinoleyl, behenyl, erucyl, and 2-octyl dodecyl alcohols. (j) Fatty alcohol ethers, including, but not limited to ethoxylated fatty alcohols of 10 to 20 carbon atoms, such as, but are not limited to, the lauryl, cetyl, stearyl, isostearyl, oleyl, and cholesterol alcohols having attached thereto from 1 to 50 ethylene oxide groups or 1 to 50 propylene oxide groups or mixtures thereof. (k) Ether-esters, such as fatty acid esters of ethoxylated fatty alcohols. (l) Lanolin and derivatives, including, but not limited to, lanolin, lanolin oil, lanolin wax, lanolin alcohols, lanolin fatty acids, isopropyl lanolate, ethoxylated lanolin, ethoxylated lanolin alcohols, ethoxylated cholesterol, propoxylated lanolin alcohols, acetylated lanolin, acetylated lanolin alcohols, lanolin alcohols linoleate, lanolin alcohols ricinoleate, acetate of lanolin alcohols ricinoleate, acetate of ethoxylated alcohols-esters, hydrogenolysis of lanolin, ethoxylated hydrogenated lanolin, ethoxylated sorbitol

- 59 -

lanolin, and liquid and semisolid lanolin absorption bases. (m) polyhydric alcohols and polyether derivatives, including, but not limited to, propylene glycol, dipropylene glycol, polypropylene glycol [M.W. 2000-4000], polyoxyethylene polyoxypropylene glycols, polyoxypropylene polyoxyethylene glycols, glycerol, ethoxylated glycerol, propoxylated glycerol, sorbitol, ethoxylated sorbitol, hydroxypropyl sorbitol, polyethylene glycol [M.W. 200-6000], methoxy polyethylene glycols 350, 550, 750, 2000, 5000, poly(ethylene oxide) homopolymers [M.W. 100,000-5,000,000], polyalkylene glycols and derivatives, hexylene glycol (2-methyl-2,4-pentanediol), 1,3-butylene glycol, 1,2,6-hexanetriol, ethohexadiol USP (2-ethyl-1,3-hexanediol), C.sub.15 -C.sub.18 vicinal glycol and polyoxypropylene derivatives of trimethylolpropane. (n) polyhydric alcohol esters, including, but not limited to, ethylene glycol mono- and di-fatty acid esters, diethylene glycol mono- and di-fatty acid esters, polyethylene glycol [M.W. 200-6000], mono- and di-fatty esters, propylene glycol mono- and di-fatty acid esters, polypropylene glycol 2000 monooleate, polypropylene glycol 2000 monostearate, ethoxylated propylene glycol monostearate, glyceryl mono- and di-fatty acid esters, polyglycerol poly-fatty acid esters, ethoxylated glyceryl monostearate, 1,3-butylene glycol monostearate, 1,3-butylene glycol distearate, polyoxyethylene polyol fatty acid ester, sorbitan fatty acid esters, and polyoxyethylene sorbitan fatty acid esters. (o) Wax esters, including, but not limited to, beeswax, spermaceti, myristyl myristate, and stearyl stearate and beeswax derivatives, including, but not limited to, polyoxyethylene sorbitol beeswax, which are reaction products of beeswax with ethoxylated sorbitol of varying ethylene oxide content that form a mixture of ether-esters. (p) Vegetable waxes, including, but not limited to, carnauba and candelilla waxes. (q) phospholipids, such as lecithin and derivatives. (r) Sterols, including, but not limited to, cholesterol and cholesterol fatty acid esters. (s) Amides, such as fatty acid amides, ethoxylated fatty acid amides, and solid fatty acid alkanolamides.

The lotions further preferably contain [by weight] from 1% to 10%, more preferably from 2% to 5%, of an emulsifier. The emulsifiers can be nonionic, anionic or cationic. Examples of satisfactory nonionic emulsifiers include, but are not limited to, fatty alcohols having 10 to 20 carbon atoms, fatty alcohols having 10 to 20 carbon atoms condensed with 2 to 20 moles of ethylene oxide or propylene oxide, alkyl phenols with 6 to 12 carbon atoms in the alkyl chain condensed with 2 to 20 moles of ethylene oxide, mono- and di-fatty acid esters of ethylene oxide, mono- and di-fatty acid esters of

- 60 -

ethylene glycol where the fatty acid moiety contains from 10 to 20 carbon atoms, diethylene glycol, polyethylene glycols of molecular weight 200 to 6000, propylene glycols of molecular weight 200 to 3000, glycerol, sorbitol, sorbitan, polyoxyethylene sorbitol, polyoxyethylene sorbitan and hydrophilic wax esters. Suitable anionic emulsifiers include, but are not limited to, the fatty acid soaps, e.g., sodium, potassium and triethanolamine soaps, where the fatty acid moiety contains from 10 to 20 carbon atoms. Other suitable anionic emulsifiers include, but are not limited to, the alkali metal, ammonium or substituted ammonium alkyl sulfates, alkyl arylsulfonates, and alkyl ethoxy ether sulfonates having 10 to 30 carbon atoms in the alkyl moiety. The alkyl ethoxy ether sulfonates contain from 1 to 50 ethylene oxide units. Among satisfactory cationic emulsifiers are quaternary ammonium, morpholinium and pyridinium compounds. Certain of the emollients described in preceding paragraphs also have emulsifying properties. When a lotion is formulated containing such an emollient, an additional emulsifier is not needed, though it can be included in the composition.

15 The balance of the lotion is water or a C<sub>2</sub> or C<sub>3</sub> alcohol, or a mixture of water and the alcohol. The lotions are formulated by simply admixing all of the components together. Preferably the compound, such as loperamide, is dissolved, suspended or otherwise uniformly dispersed in the mixture.

Other conventional components of such lotions may be included. One such additive is a thickening agent at a level from 1% to 10% by weight of the composition. Examples of suitable thickening agents include, but are not limited to: cross-linked carboxypolymethylene polymers, ethyl cellulose, polyethylene glycols, gum tragacanth, gum kharaya, xanthan gums and bentonite, hydroxyethyl cellulose, and hydroxypropyl cellulose.

25 Creams can be formulated to contain a concentration effective to deliver an effective amount of therapeutic agent(s) of the invention to the treated tissue, typically at between about 0.1%, preferably at greater than 1% up to and greater than 50%, preferably between about 3% and 50%, more preferably between about 5% and 15% therapeutic agent(s) of the invention. The creams also contain from 5% to 50%, preferably from 10% to 25%, of an emollient and the remainder is water or other suitable non-toxic carrier, such as an isotonic buffer. The emollients, as described above for the lotions, can also be used in the cream compositions. The cream may also contain a

30

- 61 -

suitable emulsifier, as described above. The emulsifier is included in the composition at a level from 3% to 50%, preferably from 5% to 20%.

These compositions that are formulated as solutions or suspensions may be applied to the skin, or, may be formulated as an aerosol or foam and applied to the skin  
5 as a spray-on. The aerosol compositions typically contain [by weight] from 25% to 80%, preferably from 30% to 50%, of a suitable propellant. Examples of such propellants are the chlorinated, fluorinated and chlorofluorinated lower molecular weight hydrocarbons. Nitrous oxide, carbon dioxide, butane, and propane are also used as propellant gases. These propellants are used as understood in the art in a quantity and under a pressure  
10 suitable to expel the contents of the container.

Suitably prepared solutions and suspensions may also be topically applied to the eyes and mucosa. Solutions, particularly those intended for ophthalmic use, may be formulated as 0.01%-10% isotonic solutions, pH about 5-7, with appropriate salts, and preferably containing one or more of the compounds herein at a concentration of about  
15 0.1%, preferably greater than 1%, up to 50% or more. Suitable ophthalmic solutions are known [see, e.g., U.S. Pat. No. 5,116,868, which describes typical compositions of ophthalmic irrigation solutions and solutions for topical application]. Such solutions, which have a pH adjusted to about 7.4, contain, for example, 90-100 mM sodium chloride, 4-6 mM dibasic potassium phosphate, 4-6 mM dibasic sodium phosphate, 8-12  
20 mM sodium citrate, 0.5-1.5 mM magnesium chloride, 1.5-2.5 mM calcium chloride, 15-25 mM sodium acetate, 10-20 mM D.L.-sodium,  $\beta$ -hydroxybutyrate and 5-5.5 mM glucose.

Gel compositions can be formulated by simply admixing a suitable thickening agent to the previously described solution or suspension compositions. Examples of  
25 suitable thickening agents have been previously described with respect to the lotions.

The gelled compositions contain an effective amount of therapeutic agent(s) of the invention, typically at a concentration of between about 0.1-50% by weight or more of one or more of the compounds provided herein.; from 5% to 75%, preferably from 10% to 50%, of an organic solvent as previously described; from 0.5% to 20%,  
30 preferably from 1% to 10% of the thickening agent; the balance being water or other aqueous or non-aqueous carrier, such as, for example, an organic liquid, or a mixture of carriers.

The formulations can be constructed and arranged to create steady state plasma

- 62 -

levels. Steady state plasma concentrations can be measured using HPLC techniques, as are known to those of skill in the art. Steady state is achieved when the rate of drug availability is equal to the rate of drug elimination from the circulation. In typical therapeutic settings, the therapeutic agent(s) of the invention will be administered to patients either on a periodic dosing regimen or with a constant infusion regimen. The concentration of drug in the plasma will tend to rise immediately after the onset of administration and will tend to fall over time as the drug is eliminated from the circulation by means of distribution into cells and tissues, by metabolism, or by excretion. Steady state will be obtained when the mean drug concentration remains constant over time. In the case of intermittent dosing, the pattern of the drug concentration cycle is repeated identically in each interval between doses with the mean concentration remaining constant. In the case of constant infusion, the mean drug concentration will remain constant with very little oscillation. The achievement of steady state is determined by means of measuring the concentration of drug in plasma over at least one cycle of dosing such that one can verify that the cycle is being repeated identically from dose to dose. Typically, in an intermittent dosing regimen, maintenance of steady state can be verified by determining drug concentrations at the consecutive troughs of a cycle, just prior to administration of another dose. In a constant infusion regimen where oscillation in the concentration is low, steady state can be verified by any two consecutive measurements of drug concentration.

Fig. 7 shows a kit according to the invention. The kit 10 includes a vial 12 containing opioid tablets. The kit 10 also includes a vial 14 containing S-MNTX tablets which comprise pellets, some of which are enterically coated with pH sensitive material and some of which are constructed and arranged to release the S-MNTX immediately in the stomach. The kit also includes instructions 20 for administering the tablets to a subject who has diarrhea or who has symptoms of diarrhea. The instructions include indicia, for example writing, indicating that the S-MNTX is pure S-MNTX free of R-MNTX.

In some aspects of the invention, the kit 10 can include optionally or alternatively a pharmaceutical preparation vial 16 and a pharmaceutical preparation diluent vial 18. The vial containing the diluent for the pharmaceutical preparation is optional. The diluent vial contains a diluent such as physiological saline for diluting what could be a concentrated solution or lyophilized powder of S-MNTX. The instructions can include

- 63 -

instructions for mixing a particular amount of the diluent with a particular amount of the concentrated pharmaceutical preparation, whereby a final formulation for injection or infusion is prepared. The instructions 20 can include instructions for treating a patient with an effective amount of S-MNTX. It also will be understood that the containers  
5 containing the preparations, whether the container is a bottle, a vial with a septum, an ampoule with a septum, an infusion bag, and the like, can contain additional indicia such as conventional markings which change color when the preparation has been autoclaved or otherwise sterilized.

This invention is not limited in its application to the details of construction and  
10 the arrangement of components set forth in the following description or illustrated in the drawings. The invention is capable of other embodiments and of being practiced or of being carried out in various ways. Also, the phraseology and terminology used herein is for the purpose of description and should not be regarded as limiting. The use of  
15 "including," "comprising," or "having," "containing", "involving", and variations thereof herein, is meant to encompass the items listed thereafter and equivalents thereof as well as additional items.

### Examples

A number of different synthetic pathways and protocols were attempted to find an  
20 efficient method for the production and purification of S-MNTX. A description of some of these are provided below. Also provided are procedures for producing reagents, intermediates and starting materials.

#### **Example I**

**Deprotection of Oxycodone to Oxymorphone.** Oxymorphone was synthesized  
25 from oxycodone. The deprotection of oxycodone to oxymorphone was done using conditions previously described in the literature. (Iijima, I.; Minamikawa, J.; Jacobson, A. E.; Brossi, A.; Rice, K. C. *J. Med. Chem.* **1978**, *21*(4), 398.) Yields ranged from 58–  
64% with purification consisting of filtration through a short plug of silica gel to remove  
30 baseline material. Purified oxymorphone was used for the alkylation reactions. Yields of oxymorphone up to 95% were obtained without purification. HPLC purities of this crude material were typically about 94%.



- 64 -

**Preparation of (Iodomethyl)cyclopropane.** (Iodomethyl)cyclopropane was prepared from (bromomethyl)cyclopropane through a Finkelstein reaction. Typical yields ranged from 68–70% and typical purities were 89–95% (AUC) by GC, with the starting bromide as the only major impurity.

5 **Direct Alkylation of Oxymorphone.** Direct alkylation of oxymorphone with cyclopropylmethyl iodide as the alkylating agent proved to give productive yields of S-MNTX. The pathway is illustrated in FIG. 2. The direct alkylation of oxymorphone was observed to proceed to nearly 50% conversion as observed by HPLC (AUC), and was investigated further.

10 Oxymorphone was combined with cyclopropylmethyl iodide in NMP (10 vol) and heated to 70 °C. The results are summarized below in Table 1. The decomposition of the alkylating agent did not completely consume the reagent during the reaction time and thus was not limiting the reaction from proceeding to completion. In addition, the ratio of oxymorphone to S-MNTX showed that the reaction proceeded to nearly 1:1  
15 regardless of the number of equivalents of alkylating agent.

**Table 1: Investigation Into the Effect of the Equivalents of Alkylating Agent Used**

Entry	Alkyl Iodide (Equiv)	Reaction Composition After 16 Hours at 70 °C (HPLC, AUC)		
		% Oxymorphone	% S-MNTX	% Alkyl Iodide
1	8	33	30	16
2	12	29	27	25
3	16	27	23	35
4	20	23	20	42
5	24	22	18	44

20 **Work up procedure.** Since the presence of NMP in the crude product was found to prevent retention, a means of removing it was required. A mixture of isopropyl acetate and dioxane formed a flocculent, a light colored solid that eventually became an oil. The use of isopropyl acetate and the mixture of isopropyl acetate/dioxane were compared to determine which was more effective at removing the  
25 NMP. In each case, the product and starting material were precipitated from the mixture and NMP remained in solution. Analysis of the supernatant liquid and the precipitated material by HPLC showed no significant difference between the two.

- 65 -

**Purification.** Once the NMP was removed from the product, the residue was subjected to repetitive sequential reverse-phase chromatography using Biotage Flash chromatography systems, equipped with C18 cartridges. Initial chromatography was carried out using 50% aqueous methanol containing 0.2% HBr as a modifier. The solvent system was incrementally reduced in methanol content until 5% aqueous methanol was settled upon. The chromatography was repeated until S-MNTX was isolated at a purity of 89% (AUC). The counterion was not detectable by MS, but was expected to be a mixture of iodide and bromide.

With the workup and purification defined, the chemistry was scaled up and 28 g of oxycodone•HCl was carried through the process. The first step, demethylation, was carried out in one reaction using the procedure described in the literature and afforded 17 g of oxymorphone, after recrystallization from hot ethanol (10 volumes). The second step was carried out in five equal smaller reactions because of equipment limitations resulting from the size and mode of heating of the pressure tubes. Although analyzed separately, the mixtures were combined for the workup and purification after analysis indicated similar composition. The isopropyl acetate trituration proceeded as expected and the precipitated residue was dissolved into 20% aqueous methanol containing 0.2% HBr and was purified by chromatography on a Biotage Flash 40s, equipped with a C18 cartridge and eluted with 5% aqueous methanol containing 0.2% HBr. The fractions were analyzed by HPLC and the fractions of similar composition were combined, separated into <80%, 80–90%, and <90% purities (AUC). The combined fractions were concentrated and rechromatographed on a Biotage Flash 75L, equipped with a C18 cartridge. This chromatographic procedure was repeated to enhance the purity. Eventually it was discovered that the HBr modifier was unnecessary and was removed from the eluent. After six chromatographic purifications, nearly 11 g of S-MNTX iodide was isolated at approximately 80% purity (AUC).

It became apparent that during the concentration of the fractions that some form of decomposition was occurring and resulted in a significant darkening of the product. The decomposition was attributed to the iodide counterion and, thus, the material was passed through an anion-exchange column to exchange the iodide for bromide. Once the eluent containing product was collected, concentration did not appear to result in the familiar darkening and afforded a yellow oil. The chromatography was continued, separating the product streams by purity level (AUC by HPLC). Once the bulk of the

- 66 -

material had been enhanced to approximately 90% purity, additional chromatography was carried out using 2.5% aqueous methanol as the eluent and eventually improved the purity of some material to >95% (AUC).

All the product streams were combined and lyophilized to afford free-flowing powders, 741 mg of S-MNTX was isolated at 95% pure, 2.5 g of S-MNTX was isolated at 90% purity, and 1.0 g of S-MNTX was isolated at 79% purity (AUC). The fractions of recovered oxymorphone were collected and recrystallized from ethanol to afford 2.4 g (>99% purity, AUC).

**Reagent Preparation.** In a series of experiments directed to producing S-MNTX, starting materials and reagents were obtained or made as described below. Equipment and instrumentation data are also provided.

All nonaqueous reactions were performed under dry nitrogen. Unless otherwise noted, reagents were purchased from commercial sources and used as received. Proton nuclear magnetic resonance spectra were obtained on a Bruker Avance 300 spectrometer at 300 MHz with tetramethylsilane used as an internal reference. Carbon nuclear magnetic resonance spectra were obtained on a Bruker Avance 300 Spectrometer at 75 MHz with the solvent peak used as the reference. Infrared spectra were obtained on a Perkin-Elmer Spectrum 1000 spectrophotometer. Mass spectra were obtained on a Finnigan mass spectrometer.

Thin layer chromatography (TLC) was performed using 2.5 × 10 cm Analtech Silica Gel GF plates (25 microns thick). Visualization of TLC plates was performed using UV and potassium permanganate stain. HPLC analysis was performed on a Varian ProStar HPLC controlled by Varian Star software using the following method:

25

**HPLC Method I:**

Column: Luna C18(2), 150 × 4.6 mm, 5 μ  
 Flow Rate: 1 mL/min  
 Detection: UV @ 230 nm  
 Gradient Program:

30

Time (min)	%A	%B
0:00	95	5
8:00	65	35
12:00	35	65
15:00	0	100

- 67 -

16:00	95	5
18:00	95	5

Mobile phase A = 0.1% Aqueous TFA

Mobile phase B = 0.1% Methanolic TFA

**HPLC Method II:**

- 5 Chromatographic Conditions and Parameters: Analytical Column Description:  
Phenomenex Inertsil ODS-3 150 x 4.6 mm, 5  $\mu$ m Column Temperature: 50.0 °C Flow  
Rate: 1.5 mL/min Injection Volume: 20  $\mu$ L Detection Wavelength: 280 nm Mobile  
Phase: A = Water : MeOH : TFA (95:5:0.1%; v/v/v) B = Water : MeOH : TFA  
(35:65:0.1%; v/v/v) Analysis Time: 50 min  
10 Quantitation limit: 0.05%  
Detection limit: 0.02%

## Gradient Profile:

Time (min)	%A	%B	Curve
0:00	100	0	Initial
45	50	50	Linear
48	100	0	Linear
55	100	0	Hold

Mobile Phase A (Water : MeOH : TFA :: 95 : 5 : 0.1%, v/v/v)

- 15 Mobile Phase B (Water : MeOH : TFA :: 35 : 65 : 0.1%, v/v/v)

MeOH = Methanol TFA = trifluoroacetic acid

- The synthesis and purification of S-MNTX were monitored using the above  
HPLC protocol. S-MNTX is distinguished from R-MNTX using the HPLC conditions  
20 described. Authentic R-MNTX for use as a standard may be made using the protocol  
described herein. In a typical HPLC run, S-MNTX elutes about 0.5 minutes before R-  
MNTX elutes. The retention time of S-MNTX is approximately 9.3 minutes; the  
retention time of R-MNTX is about 9.8 minutes.

- Gas chromatographic (GC) analysis was performed on an HP 5890 Series II GC  
25 controlled by HP 3365 ChemStation software using the following method: **GC Method:**

- Column: J&W Scientific DB-1, 30 m x 0.53 mm, 3  $\mu$   
Initial Temp: 40 °C  
Initial Time: 10.00 min  
Rate: 20 °C/min  
30 Final Temp: 250 °C  
Final Time: 2.00 min

- 68 -

Injector Temp: 250 °C  
Detector: Flame-Ionization

**Typical Alkylation Reaction.** The substrate was charged to a 250-mL Parr flask  
5 along with 10 volumes alkylating agent. If dimethyl formamide (DMF) or NMP was  
used as a cosolvent, 2.5 volumes were added. The flask was placed in a Parr shaker  
(hydrogen tank closed off) and heated to the reaction temperature with shaking under  
pressure. Pressures typically seen during the reaction were 10–15 psi. The reaction was  
periodically sampled and analyzed by MS and HPLC to determine the extent of reaction  
10 and the nature of the products. At the end of the reaction, the mixture was transferred to  
a round-bottom flask with methanol and the volatiles removed. The residue was then  
chromatographed on silica gel eluting with 90:10:0.1 methylene  
chloride/methanol/ammonium hydroxide.

**Preparation of the Ion-Exchange Column.** AG 1-X8 resin (Bio-Rad, analytical  
15 grade, 100–200 mesh, chloride form) was packed into a glass column (50 mm × 200  
mm) and was washed with 1 N HBr (1 L, prepared with deionized (DI) water). The  
column was washed with DI water (approximately 10 L) until the eluent reached a pH of  
6–7.

**Preparation of S-MNTX.** Into five, 25-mL threaded closure pressure tubes were  
20 combined oxymorphone (3.6 g, 11.9 mmol), cyclopropylmethyl iodide (17.39 g, 95.6  
mmol), and N-methyl pyrrolidone (3.6 mL). The tubes were sealed with threaded Teflon  
caps and placed into a 6-well reactor block, preheated to 70 °C. After 24 h, the reactions  
were visibly biphasic and HPLC analysis, sampling both solid and liquid phases, showed  
that the reactions proceeded to approximately 50% conversion. Heating was  
25 discontinued and the five reaction mixtures were transferred to a 1-L, round-bottom flask  
using methanol to transfer the mixtures and rinse the tubes. The methanol was removed  
under reduced pressure and the resulting NMP solution was treated with isopropyl  
acetate (900 mL), which resulted in both solid and oily precipitates. The oil was agitated  
with a spatula to afford a sticky solid. The supernatant liquid was decanted from the  
30 solid into a fluted filter paper. The solid collected in the filter paper was combined with  
the original solid, using methanol to aid in the recovery. The resulting solution was  
concentrated to a dark, viscous oil. The oil was dissolved into 20% aqueous methanol  
containing 0.2% HBr (20 mL) and was purified by chromatography on a Biotage Flash  
75L equipped with a C18 cartridge. The fractions were analyzed by HPLC on a Luna

- 69 -

C18(2) column (4 × 20 mm) and the product fractions were combined and concentrated. The resulting “purified” product dissolved into DI water (approximately 20 mL) and the chromatography was repeated with the process being repeated until the purity was enhanced to approximately 70% (AUC). The approximately 70% pure product  
5 (approximately 18 g) was dissolved into DI water (20 mL) and passed through a column of AG 1-X8 anion-exchange resin converted to the bromide form (see additional procedure) (5 × 25 cm). The column was eluted with DI water until no MNTX was detectable in the eluted stream. The aqueous solution was concentrated and the residue was dissolved into DI water (10 mL), which was purified by chromatography further  
10 using the Biotage Flash 75L system equipped with a C18 cartridge and eluted with 5% aqueous methanol. The fractions were analyzed by HPLC on a Luna C18(2) column (4.6 × 150 mm) and the product stream was partitioned into four streams based on purity (AUC); >90%, 50–90% with fast impurities, 50–90% with slow impurities, and <50%. The less-pure material was recycled through the chromatography to enhance the purity,  
15 which ultimately resulted in 3.0 g of S-MNTX that was 90% pure (AUC). The less-pure fractions were purified by chromatography further to provide approximately 1 g of 90% pure material, which was combined with 1.0 g of the 90% pure material previously isolated and purified by chromatography on a Biotage Flash 75L equipped with a C18 cartridge and eluted with 2.5% aqueous methanol. The chromatography was repeated to  
20 enhance the purity until >95% (AUC) was achieved. At the conclusion, the product streams were lyophilized from water to afford 741 mg of S-MNTX at 95.6% purity (AUC); 2.54 g of S-MNTX at 90% purity (AUC); and 1.08 g of S-MNTX at 79% purity (AUC).

FIG. 3 provides a proton NMR spectrum of S-MNTX produced by this method.  
25 FIG. 4 provides an infrared spectrum of the S-MNTX product. FIG. 5 provides an HPLC chromatogram of the S-MNTX product. FIG. 6 provides a mass spectrogram of the S-MNTX product. These analytical data identify the “S” stereoisomer of MNTX at a purity of greater than 95%.

30

## Example II

### Optimization of the Synthesis and Purification of S-MNTX

**Preparation of the Ion-Exchange Column.** AG 1-X8 Resin (Bio-Rad, analytical grade, 100–200 mesh, chloride form, 50 wt equiv) was packed into a glass

- 70 -

column and was washed with 1 N HBr (approximately 100 vol, prepared with DI water). The column was washed with DI water until the eluent reached a pH of 6–7.

**Preparation of S-MNTX.** A 250-mL, jacketed, three-neck flask was charged with oxymorphone (5.0 g, 16.6 mmol), NMP (5 mL) and copper wire (1.2 g, cut into 3–4 mm pieces). The flask was wrapped in aluminum foil and was connected to a pre-equilibrated heater/chiller set at 70 °C. Cyclopropylmethyl iodide (24.16 g, 132.7 mmol) was added to the mixture and the reaction was stirred for 20 h. Analysis of a reaction aliquot by HPLC revealed a 1:1 ratio of **2**:**3**. The reaction mixture was transferred into an Erlenmeyer flask containing IPAc (250 mL) that was vigorously stirred with an overhead mechanical stirrer. After the oily material solidified, the solid was filtered off and was transferred back into the flask; the filtrate was analyzed by HPLC and was discarded. The combined solid residues were dissolved in aqueous methanol and were filtered through a column of ion-exchange resin (Bio-Rad AG 1-X8, 50 wt equiv, converted to bromide form). The column was eluted with DI water and was rinsed until no UV active material was detected (254 nm). The resulting aqueous solution was concentrated and the residue was dissolved in IPA (5 vol) with a minimum amount of methanol to achieve solution. The solvent was stripped to remove traces of water and the resulting solid was dissolved in hot methanol (3 vol at approximately 50 °C). An ambient temperature mixture of methylene chloride/isopropyl alcohol (CH<sub>2</sub>Cl<sub>2</sub>/IPA) (6 vol/1 vol) was added and the resulting solution was allowed to stand under ambient conditions until crystallization began. The mixture was then kept in a –20 °C freezer for 2 days. The solid was collected by filtration and afforded 2.8 g of a nearly 1:1 mixture of **2** and S-MNTX. The solid was recrystallized from hot methanol (MeOH) (3 vol at approximately 50 °C) by adding CH<sub>2</sub>Cl<sub>2</sub>/IPA (6 vol/1 vol), and allowing the mixture to cool. The isolated solid (2.1 g, 29% based on weight) was found to be 94.1% pure (AUC) by HPLC analysis.

**Purification of S-MNTX.** The lots of S-MNTX of purity >94% (AUC) were combined and carried through the recrystallization procedure of dissolving in hot methanol (3 vol at approximately 50 °C) and then adding a CH<sub>2</sub>Cl<sub>2</sub>/IPA (6 vol/1 vol) mixture. The mixture was allowed to cool to ambient temperature and the solid was collected by filtration. Four iterations were required to improve the purity of S-MNTX from 94% to >99% and the overall mass recovery was 60%. In total, 8.80 g of S-MNTX were purified to 99.8%(AUC) as determined by HPLC analysis. The <sup>1</sup>H NMR, <sup>13</sup>C

- 71 -

NMR, and MS spectra were consistent with the assigned structure. Karl Fischer Analysis (KF): 4.7% water; Anal. Calcd for  $C_{21}H_{26}BrNO_4$ : C, 57.80; H, 6.01; N, 3.21; Br, 18.31. Found: C, 54.58; H, 6.10; N, 2.82; Br, 16.37.

5

### Example III

#### Opiate Receptor Binding of (S)-N-methylnaltrexone

Radioligand binding assays were conducted to determine the binding specificity of S-N-methylnaltrexone for  $\mu$ -,  $\kappa$ -, and  $\delta$ -opiate receptors using methods adapted from scientific literature (Simonin, F et al 1994, *Mol. Pharmacol* 46:1015-1021; Maguire, P. et al 1992, *Eur. J. Pharmacol.* 213:219-225; Simonin, F. et al *PNAS USA* 92(15):1431-1437; Wang, JB 1994, *FEBS Lett* 338:217-222).

10

S-MNTX was shown to bind human recombinant mu opioid receptors with a  $K_i=0.198 \mu\text{M}$ ; to bind human recombinant kappa opioid receptors with  $K_i=1.76 \mu\text{M}$ , and did not bind to human recombinant delta opioid receptors.

15

### Example IV

#### In Vitro Pharmacology of S-MNTX: $\mu$ (mu, MOP) Receptor Bioassay

**Experimental Conditions.** Segments of guinea pig terminal ileum were suspended in 20-ml organ baths filled with an oxygenated (95 %  $O_2$  and 5 %  $CO_2$ ) and pre-warmed ( $37^\circ\text{C}$ ) physiological salt solution of the following composition (in mM): NaCl 118.0, KCl 4.7,  $MgSO_4$  1.2,  $CaCl_2$  2.5,  $KH_2PO_4$  1.2,  $NaHCO_3$  25.0 and glucose 11.0 (pH 7.4). Additional experimental conditions were as described in Hutchinson et al. (1975) *Brit. J. Pharmacol.*, 55 : 541-546.

20

Indomethacin ( $1 \mu\text{M}$ ), nor-binaltorphimine ( $0.01 \mu\text{M}$ ), methysergide ( $1 \mu\text{M}$ ), ondansetron ( $10 \mu\text{M}$ ) and GR113808 ( $0.1 \mu\text{M}$ ) were also present throughout the experiments to prevent prostanoid release and to block the  $\kappa$ -opioid, 5-HT<sub>2</sub>, 5-HT<sub>3</sub> and 5-HT<sub>4</sub> receptors, respectively. The tissues were connected to force transducers for isometric tension recordings. They were stretched to a resting tension of 1 g then allowed to equilibrate for 60 min during which time they were washed repeatedly and the tension readjusted. Thereafter, they were stimulated electrically with pulses of minimal intensity to trigger maximal contractions and 1 ms duration, delivered at 0.1 Hz by a constant current stimulator. The experiments were carried out using a semi-automated isolated organ system possessing eight organ baths, with multichannel data acquisition.

30



- 72 -

### Experimental Protocols

**Test for agonist activity.** The tissues were exposed to a submaximal concentration of the reference agonist DAMGO (0.1  $\mu$ M) to verify responsiveness and to obtain a control response. Following extensive washings and recovery of the control twitch contractions, the tissues were exposed to increasing concentrations of S-MNTX or the same agonist. The different concentrations were added cumulatively and each was left in contact with the tissues until a stable response was obtained or for a maximum of 15 min. If an agonist-like response (inhibition of twitch contractions) was obtained, the reference antagonist naloxone (0.1  $\mu$ M) was tested against the highest concentration of S-MNTX to confirm the involvement of the  $\mu$  receptors in this response.

**Test for antagonist activity.** The tissues were exposed to a submaximal concentration of the reference agonist DAMGO (0.1  $\mu$ M) to obtain a control response. After stabilization of the DAMGO-induced response, increasing concentrations of S-MNTX or the reference antagonist naloxone were added cumulatively. Each concentration was left in contact with the tissues until a stable response was obtained or for a maximum of 15 min. If it occurred, an inhibition of the DAMGO-induced response by S-MNTX indicated an antagonist activity at the  $\mu$  receptors.

**Analysis and Expression of Results.** The parameter measured was the maximum change in the amplitude of the electrically-evoked twitch contractions induced by each compound concentration. The results are expressed as a percent of the control response to DAMGO (mean values). The  $EC_{50}$  value (concentration producing a half-maximum response) or  $IC_{50}$  value (concentration causing a half-maximum inhibition of the response to DAMGO) were determined by linear regression analysis of the concentration-response curves.

**Results.** The effects of S-MNTX investigated from 1.0E-08 M to 1.0E-04 M for agonist and antagonist activities at the  $\mu$ -opioid receptors in the guinea pig ileum bioassay are presented in Table IV.1 where those of the reference compounds are also reported. The  $EC_{50}$  and  $IC_{50}$  values determined for S-MNTX are indicated in Table IV.2.

In the field-stimulated guinea pig ileum, the  $\mu$  receptor agonist DAMGO induced a concentration-dependent decrease in the twitch contraction amplitude which was reversed by the antagonist naloxone in a concentration-dependent manner.

In the untreated tissues, S-MNTX also caused a concentration-dependent and

naloxone-sensitive decrease in the twitch contraction amplitude.

In the tissues previously depressed with DAMGO, S-MNTX did not produce any recovery of the twitch contraction amplitude but caused a further decrease.

These results indicate that S-MNTX behaves as an agonist at the  $\mu$ -opioid  
 5 receptors in this tissue.

**Table IV. 1**  
**Effects of S-MNTX evaluated for agonist and antagonist activities**  
**at the  $\mu$ -opioid receptors in the guinea pig ileum**

10

Evaluation of agonist activity

Compounds	Control response to DAMGO (1.0E-07 M)	Responses to increasing concentrations of the compounds (M)									+ naloxone (1.0E-07 M)
		1.0E-08	3.0E-08	1.0E-07	3.0E-07	1.0E-06	3.0E-06	1.0E-05	3.0E-05	1.0E-04	
S-MNTX	100	0	0	5	16	35	59	92	109	109	17
		1.0E-09			1.0E-08			1.0E-07			1.0E-07
DAMGO	100	12			49			99			3

15

Evaluation of antagonist activity

Compounds	Control response to DAMGO (1.0E-07 M)	Responses to DAMGO (1.0E-07 M) in the presence of increasing concentrations of the compounds (M)								
		1.0E-08	3.0E-08	1.0E-07	3.0E-07	1.0E-06	3.0E-06	1.0E-05	3.0E-05	1.0E-04
S-MNTX	100	100	100	100	100	100	102	105	109	110
		5.0E-09			2.0E-08			1.0E-07		
naloxone	100	83			43			-7		

The results are expressed as a percent of the control response to DAMGO (decrease in twitch contraction amplitude)  
(mean values; n=2)

**Table IV. 2**  
**EC<sub>50</sub> and IC<sub>50</sub> values determined for S-MNTX**  
**at the  $\mu$ -opioid receptors in the guinea pig ileum**

Compound	Agonist activity	Antagonist activity
	EC <sub>50</sub> value	IC <sub>50</sub> value
<b>S-MNTX</b>	2.0E-06 M	No antagonist activity

#### Example V

##### Effect of S-N-Methylnaltrexone on Gastrointestinal Transit in Rats

The effect of S-N-methylnaltrexone (purity- 99.81% S-N-methylnaltrexone; 0.19% oxymorphone; no detectable R-MNTX), as well as an authentic source of R-MNTX (purity 99.9%), on morphine-induced inhibition of gastrointestinal transit in rats was determined using methods described in A. F. Green, *Br. J. Pharmacol.* 14: 26-34, 1959; L. B. Witkin, C. F. et al *J. Pharmacol. Exptl. Therap.* 133: 400-408, 1961; D. E. Gmerek, et al *J. Pharmacol. Exptl. Ther.* 236: 8-13, 1986; and O. Yamamoto et al *Neurogastroenterol. Motil.* 10: 523-532, 1998.

S-MNTX or R-MNTX was administered subcutaneously to rats (CrI:CD®(SD)BR; 5-8wks old; 180-250 gms wt) at concentrations of 1.0, 3.0, or 10.0 mg/kg. A control group of rats received 2 mL/kg of a 0.9% saline solution (n=10). After 15 minutes, rats were subcutaneously injected with saline (1mL/kg) or morphine (3 mg/kg). A 10% suspension of activated charcoal in 0.25% methylcellulose was administered orally at 10 mL/kg to the rats 20 minutes ( $\pm 2$  minutes) after the subcutaneous dose of morphine or saline. The rats were euthanized 25 minutes ( $\pm 3$  minutes) after receiving the charcoal and the intestines were removed and lightly stretched on moist paper along a meterstick. The small intestine from pyloric sphincter to caecum was measured and the distance traveled by the charcoal as a fraction of that length was evaluated for each rat.

- 75 -

Statistically significant effects were determined by ANOVA with Tukey HSD Multiple Comparison Test. Differences with p values <0.05 were considered statistically significant.

Values for charcoal motility were expressed as a percent effect and were calculated in the following manner: The individual distance traveled by the charcoal in centimeters was divided by the total length of the intestines in centimeters (pyloric sphincter to caecum) for each rat. Mean values were calculated for each group, and the percent effect was calculated using the following formula:

$$\% \text{Effect} = \frac{(\text{Mean value for controls}) - (\text{Mean value for treated})}{\text{Mean value for controls}} \times 100$$

## 10 Results

The results from the GI transit study are shown in **Table 1**. Morphine, known to affect both central and peripheral opioid receptors, decreased GI motility as reported in the literature. R-MNTX, a peripherally selective mu opioid receptor antagonist, had no effect on GI transit when administered alone. R-MNTX administered prior to morphine reversed the GI slowing effect of morphine as would be expected from an opioid antagonist. The antagonist activity of R-MNTX on morphine was dose-dependent, with a partial reversal at 1 mg/kg and reversal at 3 or 10 mg/kg to the degree that GI transit was returned to values that were not statistically significantly different from the control value. In contrast to the antagonist activity of R-MNTX, S-MNTX had agonist activity when used alone, i.e. it resulted in decreased GI motility as reflected in a statistically significantly decrease in GI transit. The agonist activity of S-MNTX in decreasing GI motility was even more pronounced using S-MNTX and morphine in combination. The combination of S-MNTX + morphine had a dramatic synergistic agonist effect in decreasing GI motility to levels not observed using either compound alone. The agonist activity of S-MNTX was manifested as a slowing of GI transit when it was administered by itself and also by the increase in the inhibitory effect of morphine when the two agents were used in combination.

**Table 1**  
**Effect of S-MNTX on GI Motility**

30

- 76 -

	<b>Treatment</b>	<b>Mean Motility</b>	<b>Percent Decrease</b>
5	Saline + Saline	0.606	-
	Saline + Morphine	0.407*	33%
	R-MNTX 10mg/kg + Saline	0.572	6%
10	R-MNTX 1mg/kg + Morphine	0.463*	24%
	R-MNTX 3mg/kg + Morphine	0.558	8%
	R-MNTX 10mg/kg + Morphine	0.557	8%
15	S-MNTX 10mg/kg + Saline	0.476*	21%
	S-MNTX 1mg/kg + Morphine	0.281*	54%
20	S-MNTX 3mg/kg + Morphine	0.258*	57%
	S-MNTX 10mg/kg + Morphine	0.122*	80%

25 Route – sc  
Morphine dose= 3 mg/kg  
Mean Motility – ratio of length of charcoal transit/total intestine length  
\*Statistically significant ( $p < 0.05$ ) change when compared to the vehicle group

### 30 Example VI

#### Tests for Anti-Diarrheal Activity

- (a) Castor Oil Test in Rats [see, e.g., Niemegeers et al. (1972) *Arzneim Forsch* 22:516-518; U.S. Pat. Nos. 4,867,979; 4,990,521; 4,824,853]

Rats are fasted overnight. Each animal is treated intravenously with the desired dose of the compound to be tested. One hour thereafter, the animal receives 1 ml of castor oil orally. Each animal is kept in an individual cage and about 2 hours after the castor oil treatment, each animal is assessed for the presence or absence of diarrhea. The ED<sub>50</sub> value is determined as that dose in mg/kg body weight at which no diarrhea is present in 50% of the tested animals.

For example, young female Wistar rats (230-250 g body weight) are fasted overnight and in the morning each animal is treated orally with a dose level of the compound to be tested. One hour thereafter, the animal receives 1 ml of castor oil orally. Each animal is kept in an individual cage. At different selected time intervals (e.g., 1, 2,

- 77 -

3, 4, 6 and 8 hrs) after the castor oil treatment, the presence or absence of diarrhea is noted. In more than 95% of 500 control animals, severe diarrhea is observed 1 hour after treatment with castor oil. Using this all-or-none criterion, a significant positive effect occurs with the tested compound if no diarrhea is observed 1 hour after the castor oil  
5 treatment. A minimum of 5 dose levels are used per drug, each dose level being given to 10 rats on ten different days. The ED<sub>50</sub> value, i.e., the dose level at which such effect is observed in 50% of the animals, for the compounds, such as the compounds of formula (II), generally ranges from about 0.01 to about 10 mg/kg.

(b) Castor Oil Test in Mice [See, e.g., U.S. Patent No. 4,326,075]

10 Groups of mice are orally dosed with test compound and one-half hour later all mice are given 0.3 ml of castor oil. Three hours after castor oil administration, all of the mice are checked for diarrhea and the dose of testing compound which protected 50% of the mice from diarrhea is the ED<sub>50</sub> dose.

(c) Ricinus Oil Test [See, e.g., U.S. Pat. No. 4,990,521]

15 Rats, such as female Wistar rats or other laboratory strains, are fasted overnight. Each animal is treated orally with a dose level of the test compound. One hour thereafter, the animal is given an amount, typically 1 ml, of ricinus oil orally, each animal is kept in an individual cage and 1 hour after the ricinus oil treatment, the presence or absence of diarrhea is noted. The ED<sub>50</sub> value is determined as that dose in  
20 mg/kg body weight at which no diarrhea is present in 50% of the treated animals.

(d) Antagonism of PGE<sub>2</sub>-induced Diarrhea in Mice

Anti-diarrheal activity can be determined by assessing the effects of a compound as an antagonist of PGE<sub>2</sub>-induced diarrhea in mice [see, e.g., Dajani et al. 1975) *European Jour. Pharmacol.* 34:105-113; and Dajani et al. (1977) *J. Pharmacol. Exp. Ther.* 203:512-526; see, e.g., U.S. Pat. No. 4,870,084]. This method reliably elicits  
25 diarrhea in otherwise untreated mice within 15 minutes. Animals that are pretreated with the test agent in which no diarrhea occurs are considered protected by the test agent. The constipating effects of test agents are measured as an "all or none" response, and diarrhea is defined as watery unformed stools, very different from normal fecal matter, which has  
30 well-formed boluses, and is firm and relatively dry.

Standard laboratory mice, such as albino mice of the Charles River CD-1 strain, are used. They are typically kept in group cages. The weight range of the animals when tested is between 20-25 g. Pelleted rat chow is available ad libitum until 18 hours prior

- 78 -

to testing, at which time food is withdrawn. Animals are weighed and marked for identification. Five animals are normally used in each drug treatment group and compared with controls. Mice weighing 20-25 g are housed in group cages, and fasted overnight prior to testing. Water is available. Animals are challenged with PGE<sub>2</sub> [0.32 mg/kg i.p. in 5% ETOH] one hour after test drug treatment, and immediately placed individually, for example, in transparent acrylic boxes. A disposable cardboard sheet on the bottom of the box is checked for diarrhea on an all or nothing basis at the end of 15 minutes.

10

### **Example VII**

#### **Analgesic Activity of S-MNTX in Pain Models**

The following pain models are useful in determining the analgesic activity of S-MNTX.

##### **1. Acetic Acid Writhing assay in Mice**

15

Mice (CD-1, male) are weighed and placed in individual squares. The test or control article are administered and after the appropriate absorption time, acetic acid solution are administered intraperitoneally. Ten minutes after the i.p. injection of acetic acid, the number of writhes are recorded for a period of 5 minutes.

20

The total number of writhes for each mouse are recorded. The mean number of writhes for the control and each test article group are compared using an ANOVA followed by a relevant multiple comparison test and percent inhibition calculated.

##### **2. Phenylquinone (PPQ) Writhing Assay**

25

Mice (CD-1, male) are weighed and placed in individual squares. The test or control article are administered and after the appropriate absorption time, the PPQ solution (0.02% aqueous solution) is administered intraperitoneally. Each animal is observed closely for ten minutes for exhibition of writhing.

The total number of writhes for each mouse are recorded. The mean number of writhes for the control and each test article group are compared using an ANOVA followed by a relevant multiple comparison test and percent inhibition calculated.

30

##### **3. Randall-Selitto Assay in Rats**

The purpose of this assay is to determine the effect of test articles upon the pain threshold of rats.

Following an overnight fast, rats are placed in groups of ten. Twenty rats are used as vehicle controls. The rats are then sequentially injected with a 20% Brewer's yeast suspension into the plantar surface of the left hind paw. Two hours later the rats are administered the test article, reference drug, or control vehicle. One hour after dose administration, the pain threshold of the inflamed and non-inflamed paw is measured by a "Analgesia Meter" that exerts a force which increases at a constant rate along a linear scale.

The control group threshold and standard deviation for the inflamed paw and non-inflamed paw are calculated. Rats in the test article group and reference group are considered protected if the individual pain threshold exceeds the control group mean threshold by two standard deviations of the means.

**4. Hot Plate Analgesia Assay**

Each mouse (CD-1, male) serves as its own control throughout the experiment. The mice are placed sequentially on a Hot Plate Analgesia Meter (set for 55°C ± 2°C). The mice react characteristically to the heat stimulus by:

1. Licking the forepaw
2. Rapid fanning of the hind paw
3. A sudden jump off the hot plate

Any of the three types of reactions are taken as an end point to the heat stimulus. The mouse is removed from the hot plate immediately upon displaying the end point. The reaction time is measured quantitatively by the number of seconds that elapse between the placing of the mouse on the hot plate and the display of a definitive end point. Elapsed time is measured by a stop watch accurate to at least 1/5 of a second. Only mice whose control reaction time is 10.0 seconds or less are used. At 15, 30, 60 and 120 minutes (± 1 to 5 minutes) after test or control article administration, reaction times will be obtained and recorded for the group sequentially.

Analgesic response is an increase in reaction time of the mouse to the heat stimulus. Percent analgesia is calculated from the average response of the group of ten mice per dose level at a specified time interval:

$$\% \text{ analgesia} = \frac{\text{average response time in seconds (test article treated)}}{\text{average response time in seconds (control)}} - 1.0 \times 100$$

An ANOVA with appropriate Multiple Comparison Test is then performed.



- 80 -

### 5. Rat Tail Radiant Heat Test (Tail Flick)

To evaluate the potential ability of a test article to produce an analgesic response to thermal stimulation in rats.

Following an overnight fast, rats are weighed and placed in groups of ten. The test or vehicle control articles are administered. A Tail Flick Analgesia Meter is used. Sixty minutes following oral administration (or as recommended by the Sponsor), the tail of each rat is exposed to a specific intensity of heat stimulus and the time required to elicit a response (a characteristic tail flick) is recorded.

Percent analgesia will be calculated using the mean control response compared to the mean test article response.

### Example VIII

#### Identification of Compounds for Use as Peripheral Anti-Hyperalgesics

In general, the methods described above, are also useful for assessing peripheral anti-hyperalgesic activities of test compounds. Most preferred among the methods for assessing anti-hyperalgesic activity are those described in Niemegeers et al. (1974) *Drug Res.* 24:1633-1636.

1. Assessment of Ratio [C] of the ED<sub>50</sub> Value [A] in a Test for Anti-diarrheal Activity, Such as the Castor Oil Test, to the ED<sub>50</sub> Value [B] in a Test of CNS Effects, Such as the Tail Withdrawal Test

The agents intended for use in the methods and compositions can be identified by their activity as anti-diarrheals, and their lack of CNS effects. In particular, the selected compound exhibits anti-hyperalgesic activity in any of the standard models, discussed above, and, preferably, either (a) the ratio of these activities [B/A], as measured in standard assays, is substantially greater or equal to [at least equal to, more preferably at least about 2-fold greater] than the ratio of such activities for diphenoxylate; or (b) the activity of the compound in an assay that measures CNS activity is substantially less [at least two-fold, preferably 3-fold or more] than diphenoxylate.

### Example IX

#### In Vitro Pharmacology of S-MNTX: cAMP Assay in CHO Cells Expressing Human $\mu$ (mu, MOP) Receptor

- 81 -

The mu opioid receptor is  $G_i$  coupled, which works by inhibiting a cAMP increase. Thus in these experiments, cellular cAMP was increased by addition of 10 $\mu$ M forskolin. Prior addition of DAMGO, or similar agonists, e.g. endomorphin-1, fentanyl, or morphine, inhibited this forskolin-induced increase. The absence of agonist effect, produced a result equivalent to forskolin alone. Therefore, increasing agonist concentration decreased cAMP levels.

Antagonists, such as CTOP, naloxone and ciprodimine inhibited the cAMP inhibition. Thus full antagonist effect was equivalent to forskolin without any addition of  $\mu$ -opioid agonist. In these experiments, antagonist was added, then 30 $\mu$ M DAMGO, then forskolin. Therefore, increasing antagonist concentration increased cAMP.

## **Experimental Protocol**

### Assay Characteristics:

EC50 (DAMGO): 12nM  
cAMP production  
(with forskolin & IBMX): 3.4 pmol/well  
Inhibition (10 $\mu$ M DAMGO): 90%

### Materials and Methods:

Cell Source: Human recombinant/CHO cells  
Reference Agonist: DAMGO  
Reference Inhibitor: CTOP (see antagonist SAP)  
Reference Curve: DAMGO (cell activation)  
cAMP (EIA control curve)

Cells were grown to confluence in 96-well plates. Cells were washed and equilibrated in physiological buffer before analysis. 20 ul of drug, 100 $\mu$ M IBMX and 10 $\mu$ M forskolin were added and incubated for 25 minutes at room temperature and then the reaction was stopped with the addition of 0.1 N HCl. Extracted cAMP level was determined via competitive EIA assay utilizing alkaline phosphatase. Additional experimental conditions were as described in Toll L., J Pharmacol Exp Ther. (1995) 273(2): 721-7.

- 82 -

**Results**

Agonist Assay: S-MNTX demonstrated an agonist response with EC50 of 600nM. (6.0E-7M) as shown in Table IX.1. The agonist response was complete (not partial).

5

**Table IX.1**

log{M} conc	S-MNTX	SD	DAMGO	SD
-4.0	3	6	-1	3
-4.5	-3	1		
-5.0	4	9	2	5
-5.5	11	6		
-6.0	32	7	1	6
-6.5	66	21		
-7.0	70	17	2	6
-7.5	79	24		
-8.0	104	10	68	28
-9.0	86	5	63	10
-10.0			88	22
-11.0			105	13

Antagonist Assay: S-MNTX showed no antagonist effect, as it is demonstrated by the results presented in Table X. 2.

**Table IX. 2**

log{M} conc	S-MNTX	Range	CTOP	Range
-4.0	-13	5		
-4.5	-13	1		
-5.0	-9	3	91	11
-5.5	-8	7		
-6.0	-1	17	109	11
-6.5	9	1		
-7.0	5	7	48	3
-7.5	6	7		
-8.0	4	6	1	1
-9.0	0	4		
-10.0				
-11.0			-1	1

10

Having thus described several aspects of at least one embodiment of this invention, it is to be appreciated various alterations, modifications, and improvements

- 83 -

will readily occur to those skilled in the art. Such alterations, modifications, and improvements are intended to be part of this disclosure, and are intended to be within the spirit and scope of the invention. Accordingly, the foregoing description and drawings are by way of example only.

5

What is claimed is:

## CLAIMS

1. An isolated compound of the S configuration with respect to nitrogen of  
5 Formula I:

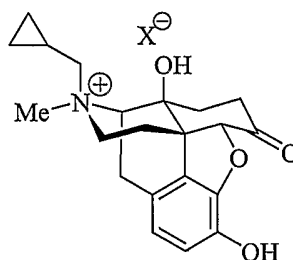

wherein X is a counterion.

2. The isolated compound of claim 1, wherein the counterion is a halide,  
10 sulfate, phosphate, nitrate, or anionic-charged organic species.
3. The isolated compound of claim 2, wherein the counterion is a halide.
4. The isolated compound of claim 3, wherein the halide is bromide.  
15
5. The isolated compound of claim 3, wherein the halide is iodide.
6. The isolated compound of claim 1, having at least 75% purity.
7. The isolated compound of claim 1, having at least 90% purity.  
20
8. The isolated compound of claim 1, having at least 95% purity.
9. The isolated compound of claim 4, having at least 75% purity.
10. The isolated compound of claim 4, having at least 90% purity.  
25
11. The isolated compound of claim 4, having at least 95% purity.

- 85 -

12. The isolated compound of claims 1-11, wherein the isolated compound is in a crystal form.

13. A composition comprising MNTX, wherein the MNTX present in the composition is greater than 10 % in S configuration with respect to nitrogen.

14. The composition of claim 13, wherein the MNTX present in the composition is greater than 30 % in S configuration with respect to nitrogen.

15. The composition of claim 13, wherein the MNTX present in the composition is greater than 50 % in S configuration with respect to nitrogen.

16. The composition of claim 13, wherein the MNTX present in the composition is about 75 % in S configuration with respect to nitrogen.

17. The composition of claim 13, wherein the MNTX present in the composition is about 90 % in S configuration with respect to nitrogen.

18. The composition of claim 13, wherein the MNTX present in the composition is about 95 % in S configuration with respect to nitrogen.

19. The composition of claim 13, wherein the MNTX present in the composition is about 98 % in S configuration with respect to nitrogen.

20. The composition of claim 13, wherein the MNTX present in the composition is greater than 99 % in S configuration with respect to nitrogen.

21. The composition of claim 13, wherein the MNTX has a counterion that is a halide, sulfate, phosphate, nitrate, or anionic-charged organic species.

30

22. The composition of claim 21, wherein the counterion is a halide.

23. The composition of claim 22, wherein the halide is iodide.

- 86 -

24. The composition of claim 22, wherein the halide is bromide.

25. The composition of any of claims 13-24, wherein the composition is a  
5 solution.

26. The composition of any of claims 13-24, wherein the composition is a  
solid.

10 27. A pharmaceutical composition comprising an effective amount of the  
composition of any of claims 13-24, and a pharmaceutically acceptable carrier.

28. The pharmaceutical composition of claim 27, further comprising a  
therapeutic agent other than MNTX.

15 29. The pharmaceutical composition of claim 28, wherein the therapeutic  
agent is an opioid or opioid agonist.

20 30. The pharmaceutical composition of claim 29, wherein the opioid is  
selected from the group consisting of alfentanil, anileridine, asimadoline,  
bremazocine, burprenorphine, butorphanol, codeine, dezocine, diacetylmorphine  
(heroin), dihydrocodeine, diphenoxylate, fedotozine, fentanyl, funaltrexamine,  
hydrocodone, hydromorphone, levallorphan, levomethadyl acetate, levorphanol,  
loperamide, meperidine (pethidine), methadone, morphine, morphine-6-glucuronide,  
25 nalbuphine, nalorphine, opium, oxycodone, oxymorphone, pentazocine, propiram,  
propoxyphene, remifentanyl, sufentanil, tilidine, trimebutine, tramadol, and  
combinations thereof.

31. The pharmaceutical composition of claim 29, wherein the opioid or opioid  
30 agonist has substantially no central nervous system (CNS) activity.

32. The pharmaceutical composition of claim 28, wherein the therapeutic  
agent is not an opioid, opioid agonist, or an opioid antagonist.

- 87 -

33. The pharmaceutical composition of claim 28, wherein the therapeutic agent is an antiviral agent, an antibiotic agent, an antifungal agent, antibacterial agent, antiseptic agent, anti-protozoal agent, anti-parasitic agent, an anti-  
5 inflammatory agent, a vasoconstrictor agent, a local anesthetic agent, an anti-diarrheal agent, an anti-hyperalgesia agent, or combinations thereof.

34. The pharmaceutical composition of claim 28, wherein the therapeutic agent is an anti-diarrhea agent that is loperamide, loperamide analogs, N-oxides of  
10 loperamide and analogs, metabolites and prodrugs thereof, diphenoxylate, cisapride, antacids, aluminum hydroxide, magnesium aluminum silicate, magnesium carbonate, magnesium hydroxide, calcium carbonate, polycarbophil, simethicone, hyoscyamine, atropine, furazolidone, difenoxin, octreotide, lansoprazole, kaolin, pectin, activated charcoal, sulphaguanidine, succinylsulphathiazole, phthalylsulphathiazole, bismuth  
15 aluminate, bismuth subcarbonate, bismuth subcitrate, bismuth citrate, tripotassium dicitrate bismuthate, bismuth tartrate, bismuth subsalicylate, bismuth subnitrate and bismuth subgallate, opium tincture (paregoric), herbal medicines, plant-derived anti-diarrheal agents or combinations thereof.

20 35. The pharmaceutical composition of claim 28, wherein the therapeutic agent is an anti-inflammatory agent that is a non-steroidal anti-inflammatory drug (NSAID), a tumor necrosis factor inhibitor, basiliximab, daclizumab, infliximab, mycophenolate, mofetil, azothioprine, tacrolimus, steroids, sulfasalazine, olsalazine, mesalamine, or combinations thereof.

25 36. The pharmaceutical composition of claim 28, wherein the therapeutic agent is an anti-viral agent.

30 37. The pharmaceutical composition of claim 28, wherein the therapeutic agent is an anti-bacterial agent.

38. The pharmaceutical composition of claim 28, wherein the therapeutic agent is an anti-hyperalgesia agent.



39. The pharmaceutical composition of claim 27 wherein the composition is enterically coated.

5 40. The pharmaceutical composition of claim 27 wherein the composition is in a controlled release or sustained release formulation.

41. The pharmaceutical composition of claim 27 wherein the composition is a solution.

10 42. The pharmaceutical composition of claim 27, wherein the composition is a topical formulation.

15 43. The pharmaceutical composition of claim 27, wherein the composition is lyophilized.

44. The pharmaceutical composition of claim 27, wherein the composition is a suppository.

20 45. An inhaler containing the pharmaceutical composition of claim 27.

46. A nasal spray device containing the pharmaceutical composition of claim 27.

25 47. A method for synthesizing a salt of S-MNTX comprising:  
combining (iodomethyl) cyclopropane with oxymorphone in a first solvent to produce an iodo salt of S-MNTX.

30 48. The method of claim 47 further comprising, transferring the iodo salt S-MNTX to a second solvent; and exchanging iodide for a counterion other than iodide.

- 89 -

49. The method of claim 47 further comprising, transferring the iodo salt of S-MNTX to a second solvent, and exchanging iodide for bromide to produce a bromo salt of S-MNTX.

5 50. The method of claim 47, wherein the first solvent comprises N-methylpyrrolidone.

51. The method of claim 49, wherein the second solvent comprises at least isopropyl acetate or dioxane.

10

52. The method of claim 49, wherein the first solvent is N-methylpyrrolidone and the second solvent is isopropyl acetate or dioxane.

53. The method of claim 47, further comprising purifying the salt of S-MNTX by chromatography, recrystallization, or a combination thereof.

15

54. The method of claim 49, further comprising purifying the salt of S-MNTX by chromatography, recrystallization, or a combination thereof.

20 55. The method of claim 54, wherein the purification is by multiple recrystallizations.

56. The method of claim 47, wherein the method is conducted under a controlled reaction temperature between 65° to 75° C.

25

57. The method of claim 50, wherein the method is conducted under a controlled reaction temperature between 65° to 75° C.

58. The method of claim 52, wherein the combining (iodomethyl) cyclopropane with oxymorphone in a first solvent to produce an iodo salt of S-MNTX is conducted under a controlled reaction temperature between 65° to 75° C, wherein the

30

- 90 -

exchanging iodide for bromide to produce a bromo salt of S-MNTX is conducted at room temperature, and wherein the first solvent is N-methylpyrrolidone and the second solvent is isopropyl acetate or dioxane.

5            59.    A method for inhibiting diarrhea in a subject comprising administering to a subject in need of such treatment the pharmaceutical composition of claim 27 in an amount effective to treat or prevent the diarrhea.

10           60.    The method of claim 59, further comprising administering to the subject an anti-diarrhea agent that is not S-MNTX.

            61.    The method of claim 60, wherein the anti-diarrhea agent that is not S-MNTX is an opioid or an opioid agonist.

15           62.    A method of reducing a volume of discharge from a ileostomy or cholostomy in a subject comprising administering to the subject in need of such reduction the pharmaceutical composition of claim 27 in an amount effective to reduce the volume of discharge from the ileostomy or cholostomy.

20           63.    A method of reducing a rate of discharge from a ileostomy or cholostomy in a subject comprising administering to the subject in need of such reduction the pharmaceutical composition of claim 27 in an amount effective to reduce the rate of discharge from the ileostomy or cholostomy.

25           64.    A method for inhibiting gastrointestinal motility in a subject in need of such treatment comprising administering to the subject a pharmaceutical composition of claim 27 in an amount effective to inhibit gastrointestinal motility in the subject.

30           65.    The method of claim 64 further comprising administering to the subject an opioid or an opioid agonist.

            66.    A method for treating irritable bowel syndrome comprising administering to a patient in need of such treatment the pharmaceutical composition of claim 27, in

- 91 -

an amount effective to ameliorate at least one symptom of the irritable bowel syndrome.

5 67. A method for inhibiting pain in a subject comprising administering the pharmaceutical composition of claim 27 in an amount sufficient to prevent or treat the pain.

68. The method of claim 67 further comprising administering to the subject a therapeutic agent other than S-MNTX.

10 69. The method of claim 68, wherein the therapeutic agent other than S-MNTX is an opioid.

15 70. The method of claim 68, wherein the therapeutic agent other than S-MNTX is an antiviral agent, an antibiotic agent, an antifungal agent, antibacterial agent, antiseptic agent, anti-protozoal agent, anti-parasitic agent, an anti-inflammatory agent, a vasoconstrictor agent, a local anesthetic agent, an anti-diarrheal agent, or an anti-hyperalgesia agent.

20 71. The method of claim 67, wherein the pain is peripheral hyperalgesia.

72. The method of claim 67, wherein the pharmaceutical composition is administered locally to a site of the pain.

25 73. The method of claim 67, wherein the administration is intra-articular.

74. The method of claim 67, wherein the administration is systemic.

75. The method of claim 67, wherein the administration is topical.

30 76. The method of claim 67, wherein the composition is administered to the eye.

- 92 -

77. A method for inhibiting inflammation in a subject comprising administering to a subject in need thereof the pharmaceutical composition of claim 27 in an amount effective to inhibit the inflammation.

5 78. The method of claim 77 further comprising administering to the subject a therapeutic agent other than S-MNTX.

79. The method of claim 78 wherein the therapeutic agent other than S-MNTX is an anti-inflammatory agent.

10

80. The method of claim 77 wherein the administration is local administration at a site of the inflammation.

15

81. The method of claim 77, wherein the administration is systemic administration.

82. The method of claim 77, wherein the administration is topical administration.

20

83. A method of inhibiting production of tumor necrosis factor (TNF) in a subject, comprising:  
administering to the subject a composition comprising TNF production-inhibitory amount of a pharmaceutical composition of claim 27.

25

84. A kit comprising a package containing a sealed container comprising the pharmaceutical composition of claim 27 and instructions for use.

85. The kit according to claim 84, further comprising a therapeutic agent other than S-MNTX.

30

86. The kit according to claim 85, wherein the therapeutic agent is an opioid or opioid agonist.

- 93 -

87. The kit according to claim 86, wherein the opioid or opioid agonist has substantially no CNS activity.

5 88. The kit according to claim 86, wherein the therapeutic agent is an antiviral agent, an antibiotic agent, an antifungal agent, antibacterial agent, antiseptic agent, anti-protozoal agent, anti-parasitic agent, an anti-inflammatory agent, a vasoconstrictor agent, a local anesthetic agent, an anti-diarrheal agent, or an anti-hyperalgesia agent, or combinations thereof.

10 89. The kit according to claim 85, wherein the therapeutic agent is a peripheral opioid antagonist.

90. The kit according to claim 89, wherein the peripheral opioid antagonist is R-MNTX.

15 91. The kit according to claim 89, wherein the peripheral opioid antagonist is a piperidine N-alkylcarboxylate, a quarternary derivative of noroxymorphone, an opium alkaloid derivative, or a quarternary benzomorphan.

20 92. A method for regulating gastrointestinal function comprising administering to a subject in need thereof S-MNTX, and administering to the subject a peripheral mu opioid antagonist.

25 93. The method of claim 92 wherein the peripheral mu opioid antagonist is R-MNTX.

94. The method of claim 92, wherein the peripheral opioid antagonist is a piperidine N-alkylcarboxylate, a quarternary derivative of noroxymorphone, an opium alkaloid derivative, or a quarternary benzomorphan.

30 95. A method for manufacturing S-MNTX comprising the following steps,  
(a) obtaining a first composition containing S-MNTX,

- 94 -

(b) purifying the first composition by chromatography, recrystallization or a combination thereof,

(c) conducting HPLC on a sample of purified first composition using S-MNTX as a standard,

5 (d) determining the presence or absence of R-MNTX in the sample.

96. The method of claim 95, wherein the purifying comprises multiple recrystallization steps or multiple chromatography steps.

10 97. The method of claim 95, wherein the purifying is carried out until R-MNTX is absent from the sample as determined by HPLC.

98. The method of claim 96, wherein the purifying is carried out until R-MNTX is absent from the sample as determined by HPLC.

15

99. The method of claims 97, further comprising packaging purified first composition that is free of HPLC detectable R-MNTX.

100. The method of claims 98, further comprising packaging purified first  
20 composition that is free of HPLC detectable R-MNTX.

101. The method of claims 99, further comprising providing indicia on or with the packaged, purified first composition indicating that the packaged, purified first composition is free of HPLC detectable R-MNTX.

25

102. The method of claims 100, further comprising indicating that the packaged, purified first composition is free of HPLC detectable R-MNTX.

103. A package containing a composition comprising S-MNTX, wherein the  
30 composition is free of HPLC detectable R-MNTX, and indicia on or contained within the package indicating that the composition is free of detectable R-MNTX.

- 95 -

104. The package of claim 103, wherein the composition is a pharmaceutical composition.



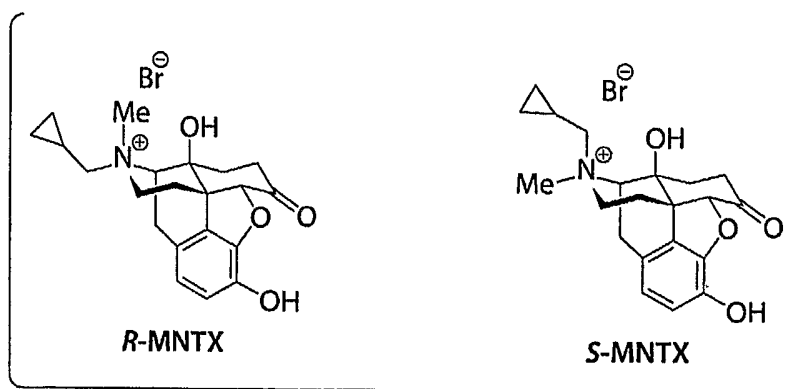

Fig. 1

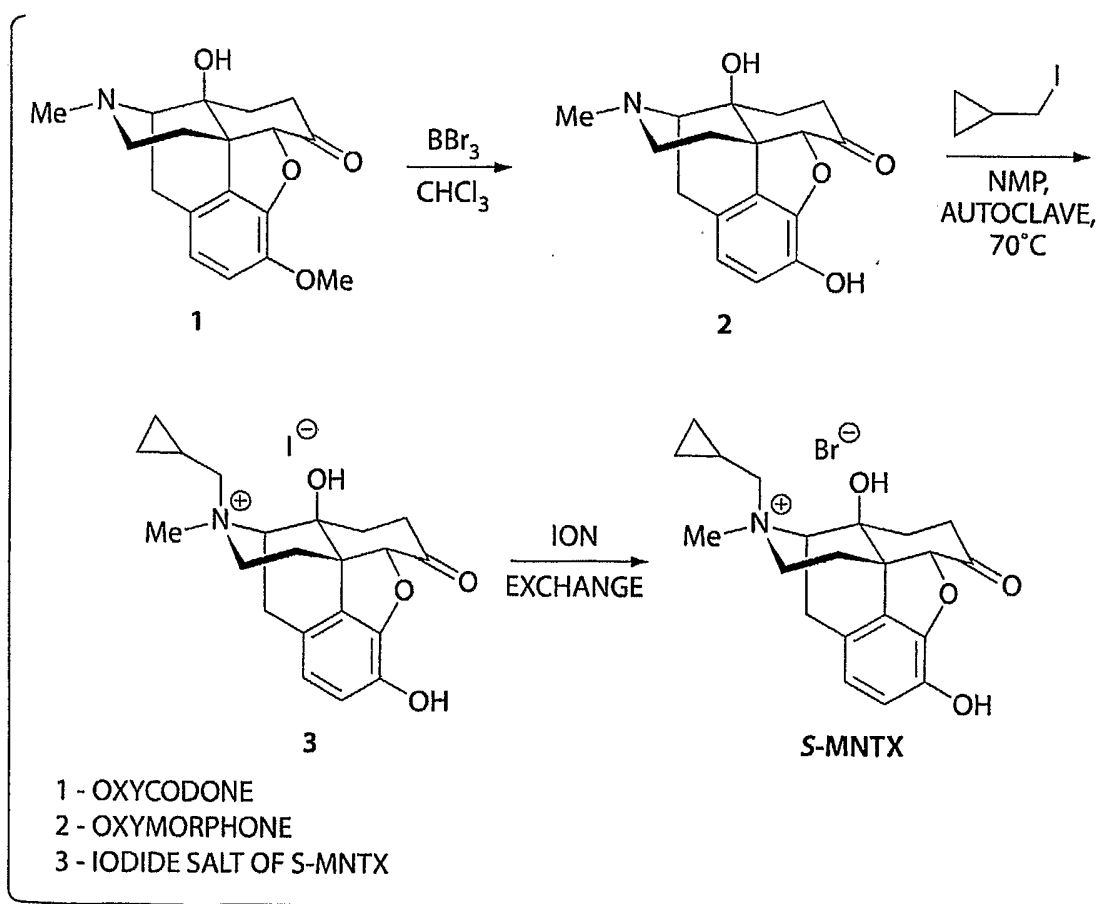

Fig. 2

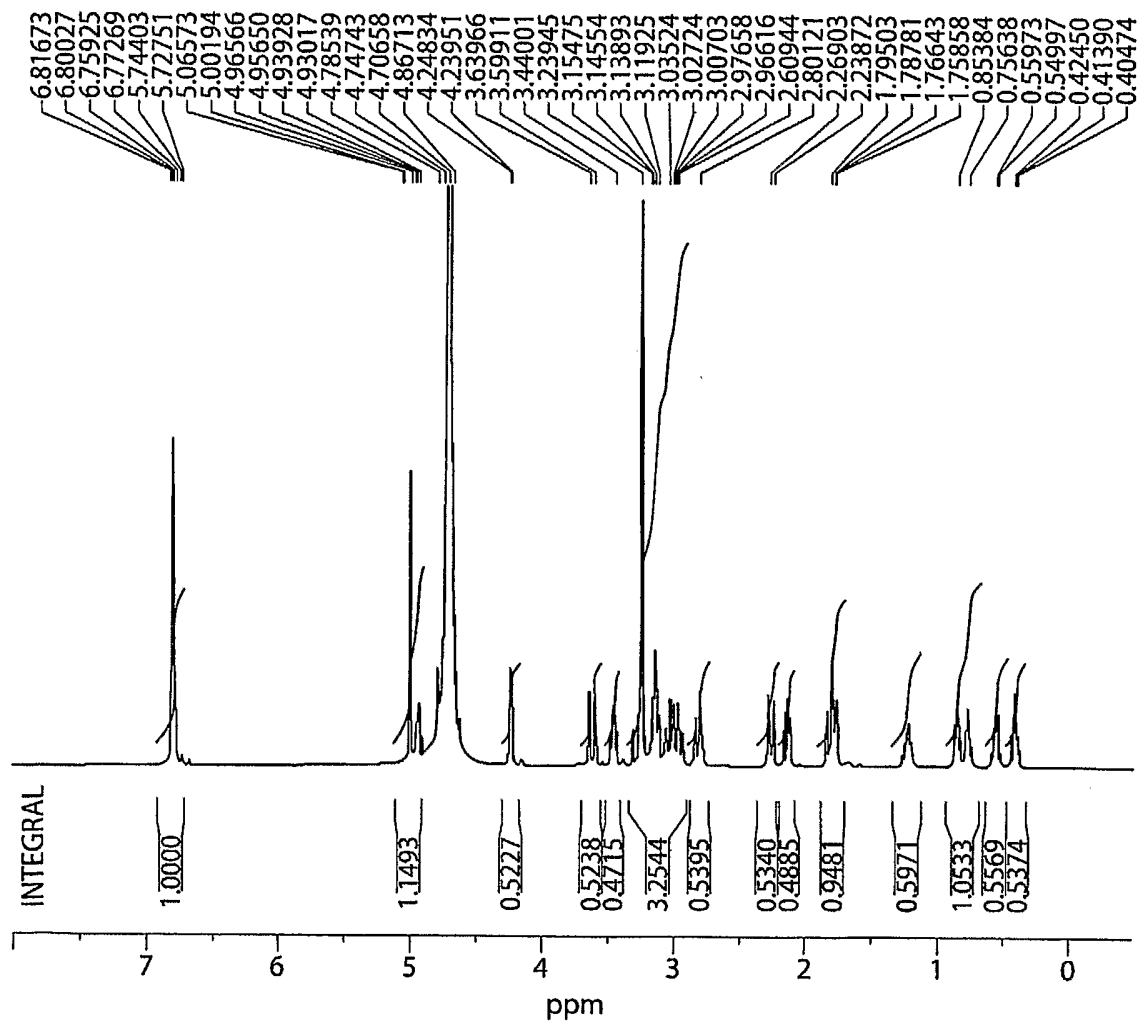
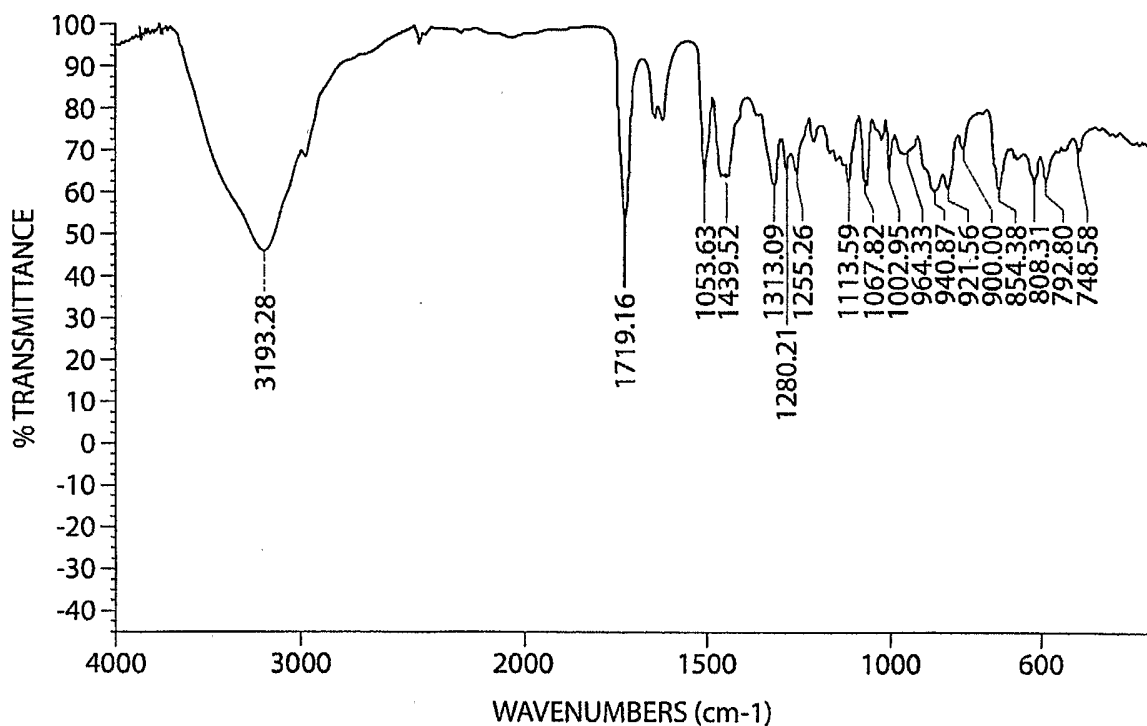

Fig. 3



DETECTOR: DTGS KBr  
 BEAMSPLITTER: KBr  
 SOURCE: IR  
 NUMBER OF SAMPLE SCANS: 32  
 NUMBER OF BACKGROUND SCANS: 32  
 RESOLUTION: 4.000  
 SAMPLE GAIN: 4.0  
 MIRROR VELOCITY: 0.6329  
 APERTURE: 100.00

Fig. 4

METHOD NOTES

LUNA C13(2), 5a 4.6 x 150 mm  
 FLOW 1.0 ml/min. MONITORED @ 230 nm  
 A-0.1% Aq. TFA B-0.1% TFA IN MeOH

INJECTION METHOD: 0.0 start3814\_lura\_el8(2)\_long uv  
 PEAK MEASUREMENT: PEAK AREA  
 INJECTION NOTES: S-MNTX

TIME	N/A	%B
0:00	95	5
8:00	65	35
12:00	25	65
15:00	0	100
16:00	95	5
18:00	95	5

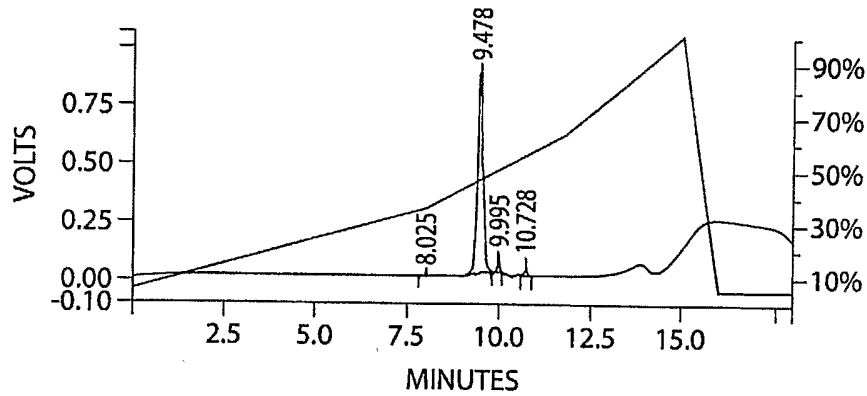

PEAK NO.	RET. TIME (MIN)	AREA (COUNTS)	SEP. CODE	WIDTH 1/2 (SEC)	RESULT 0
1	8.025	26031	BB	6.6	0.2607
2	9.478	9551224	BB	8.3	95.6377
3	9.995	259922	BB	5.8	2.6026
4	10.728	149702	BB	5.5	1.4990
9986879					100.0000

Fig. 5

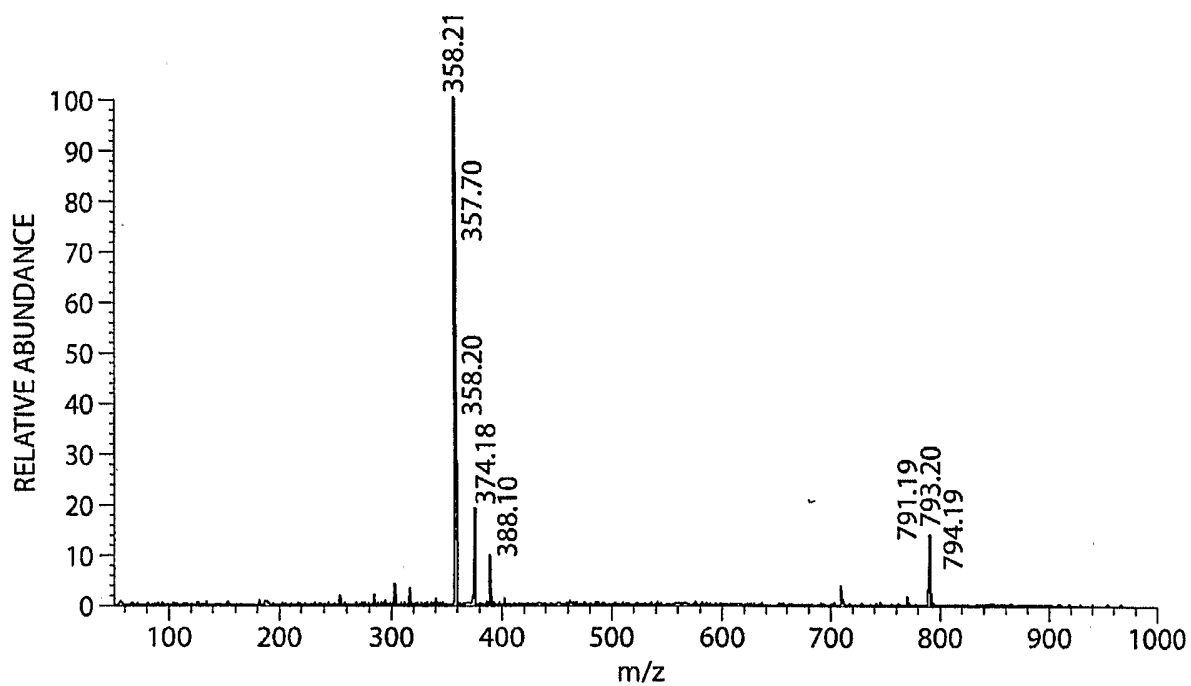

Fig. 6

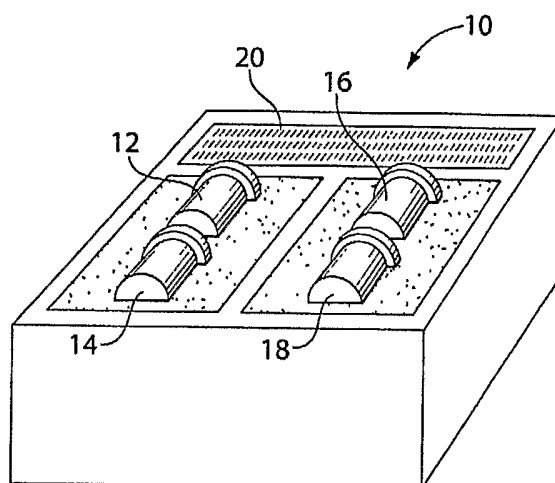

Fig. 7