

Jan. 23, 1962

H. H. NELSON

3,017,890

CIGARETTE HOLDER PIN

Filed Sept. 22, 1960

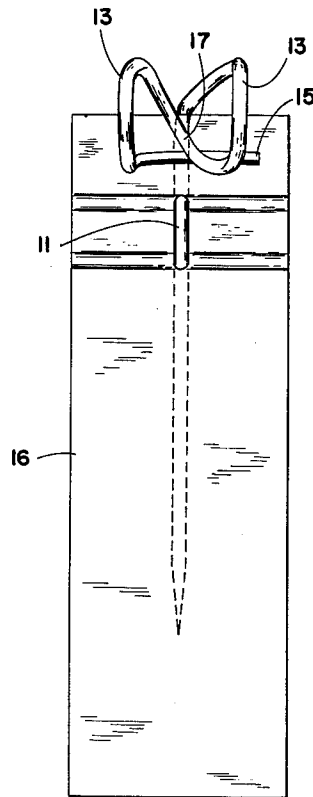
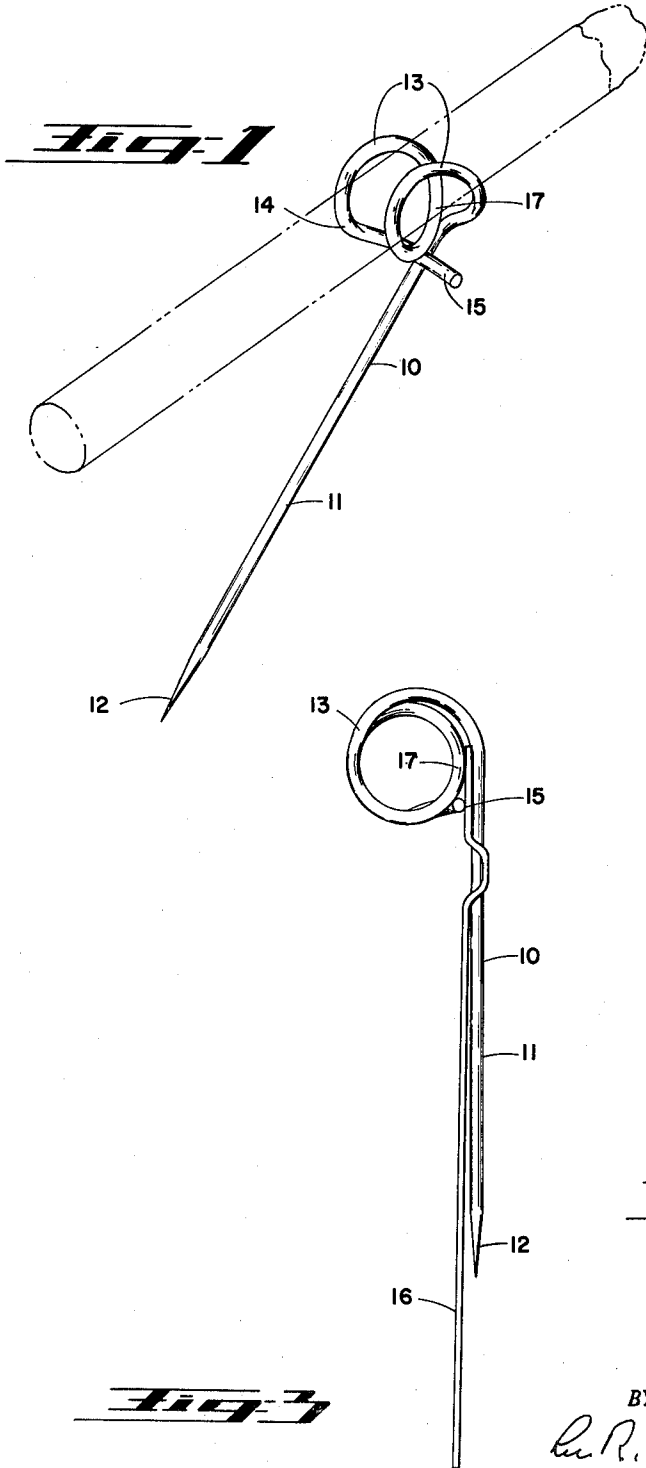

Fig. 2

INVENTOR.
HANS H. NELSON

BY
H. R. Schumacher
ATTORNEY

1

3,017,890

CIGARETTE HOLDER PIN

Hans H. Nelson, Rte. 2, Box 1018, Troutdale, Oreg.

Filed Sept. 22, 1960, Ser. No. 57,775

2 Claims. (Cl. 131-259)

This invention relates generally to a pin-type cigarette holder and has particular reference to a novelty device having available space for advertising or other information.

Objects of the invention are to provide a cigarette holder having a pin-type of support which may be applied to any surface or material capable of being pierced by the pin, to provide a cigarette holder having available space for advertising or other information and to provide a device of the type described which is very simple and inexpensive to manufacture.

The pin and cigarette holder portion of the present device is made from a single length of wire having a pointed pin shank and a pair of cigarette holding loops whereby the device can readily be formed at low cost in an automatic machine. Impaled on the pin or otherwise attached thereto is a plate or card having space available for advertising or other information which will be presented to view when the device is in use.

Still other objects and advantages will become apparent and the invention will be better understood with reference to the following description of the preferred embodiment illustrated in the accompanying drawing. Various changes may be made, however, in the construction and arrangement of parts and certain parts may be used without others, all such modifications within the scope of the appended claims being included in the invention.

In the drawing:

FIGURE 1 is a perspective view of the pin and holder portion of the present device showing in phantom outline a cigarette held in the device;

FIGURE 2 is a front elevation view of the complete device; and

FIGURE 3 is a side elevation view showing how the plate portion is secured on the wire portion of the device.

The pin and cigarette holder portion of the present device is made from a length of stiff wire 10 having on one end a straight shank 11 with a pointed extremity 12. An intermediate portion of the wire is curled into a pair of generally parallel spring loops 13 spaced apart a suitable distance to grip a cigarette therebetween. One of the loops 13 continues from the straight shank portion 11 and continues into the second loop, following which the wire is formed with a right angle bend at 14 causing the end portion 15 to lie across the shank 11 at right angles thereto and also perpendicular to the planes of the loops 13.

The loops and bend just described are formed in such a manner as to cause the transverse end portion 15 to bear resiliently against shank 11 and form a clamp against the upper end of a plate 16 impaled on the shank. The wire portion 17 between the loops 13 also serves as a clamping foot against the upper end of shank 11 to provide additional retention for plate 16.

Thus, the plate 16 may be securely retained on the pin

2

and held in a position perpendicular to the loops 13 without any additional means of attachment. In some cases, however, depending upon the material of the plate 16, it may be found desirable to attach this plate to the pin by some other means. The plate 16 is formed of a readily pierceable and flexible material, preferably thin gauge sheet metal or a heavy metal foil but it may also be formed of a fireproofed cardboard or plastic material, if desired. In assembling the device the point of the pin is merely thrust through the material of the plate, as shown.

Such a pin-type of support or cigarette holder is often advantageous where there is no convenient supporting surface for a conventional type of ash tray. For example, the present pin may be used on a fabric or plastic sun visor covering in an automobile or on such a covering around or adjacent an automobile instrument panel where the holder will be in a more convenient position than the automobile ash tray. When so used, any advertising matter printed on the plate 16 is clearly in view.

The device also may be used on the coat lapel as an identification badge for conventions and other business and social functions. When the function of the identification badge is no longer needed, the plate 16 may be readily detached leaving the wire portion of the device available for use thereafter as a cigarette holder in the manner described. The present device is also attractive and useful as a novelty to be given away with merchandise or services or to be included as a premium in connection with a purchase.

Having now described my invention and in what manner the same may be used, what I claim as new and desire to protect by Letters Patent is:

1. A cigarette holder pin comprising a length of wire forming a pair of spaced generally parallel loops arranged to grip a cigarette therebetween, a straight, pointed shank on one end of said wire directed away from said loops, a flat plate impaled on said shank, and a clamping foot on the other end of said wire clamping one end of said plate against said shank in a position perpendicular to said loops.

2. A cigarette holder pin comprising a length of wire forming a pair of spaced generally parallel loops arranged to grip a cigarette therebetween, a straight, pointed shank on one end of said wire directed away from said loops, a flat plate impaled on said shank, and a transverse portion on the opposite end of said wire lying across said shank and clamping said plate thereagainst.

References Cited in the file of this patent

UNITED STATES PATENTS

335,141	Mitchell	Feb. 2, 1886
578,652	Morrison	Mar. 9, 1897
1,170,081	McCay	Feb. 1, 1916
2,207,197	Havey	July 9, 1940
2,250,178	Brush	July 22, 1941

FOREIGN PATENTS

558,220	France	May 19, 1923
804,730	Germany	Apr. 30, 1951