

- [54] **APPARATUS FOR THERMIC DEVELOPMENT OF HEAT-SENSITIVE PAPER**
- [76] Inventor: **Francis Ingels**, 29, rue des Rossignols, Saint Andre, France
- [22] Filed: **Jan. 8, 1971**
- [21] Appl. No.: **105,019**
- [30] **Foreign Application Priority Data**  
 Jan. 8, 1970 France ..... 7000652
- [52] **U.S. Cl.**..... **95/89 R, 95/94 R, 34/41, 34/48, 34/123, 219/216**
- [51] **Int. Cl.** ..... **G03d 3/00**
- [58] **Field of Search** ..... **95/89, 94; 219/216; 34/111, 116, 117, 118, 123, 48, 41**

- [56] **References Cited**  
**UNITED STATES PATENTS**
- |           |         |                      |          |
|-----------|---------|----------------------|----------|
| 3,027,822 | 4/1962  | Frantz.....          | 95/89 G  |
| 3,629,549 | 12/1971 | Svendsen .....       | 219/216  |
| 3,032,811 | 5/1962  | Knowland et al.....  | 34/41 X  |
| 3,061,940 | 11/1962 | Cichelli.....        | 34/41 X  |
| 3,440,944 | 4/1969  | Endermann et al..... | 95/89 R  |
| 3,330,942 | 7/1967  | Whitson.....         | 236/95 X |

3,215,055	11/1965	Campbell.....	355/106
3,283,647	11/1966	Fairbanks et al. ....	95/89 R X
3,478,665	11/1969	Umahashi et al. ....	34/48 X
3,311,040	3/1967	Ishikawa .....	95/94 R
3,145,637	8/1964	Frantz.....	34/41 X
2,896,336	7/1959	Shaumatoff.....	34/116 X
2,578,633	12/1951	Mauffre.....	34/41

*Primary Examiner*—Samuel S. Matthews  
*Assistant Examiner*—Richard M. Sheer  
*Attorney*—William B. Kerkam, Jr.

[57] **ABSTRACT**

Apparatus for thermic development of heliographic paper and diazo copies comprises a drum rotating in an insulated compartment, a stationary tensioned fabric sheet extending around the drum to hold the copy against the drum and a heating element in the form of a thin sheet applied directly to the drum or the fabric sheet. Air is circulated through a space between the insulated compartment and an outer housing, entering at the front of the housing at an opening through which paper is fed to and discharged from the drum, passing over the top of the insulated compartment and being discharged at the rear of the housing.

**11 Claims, 2 Drawing Figures**

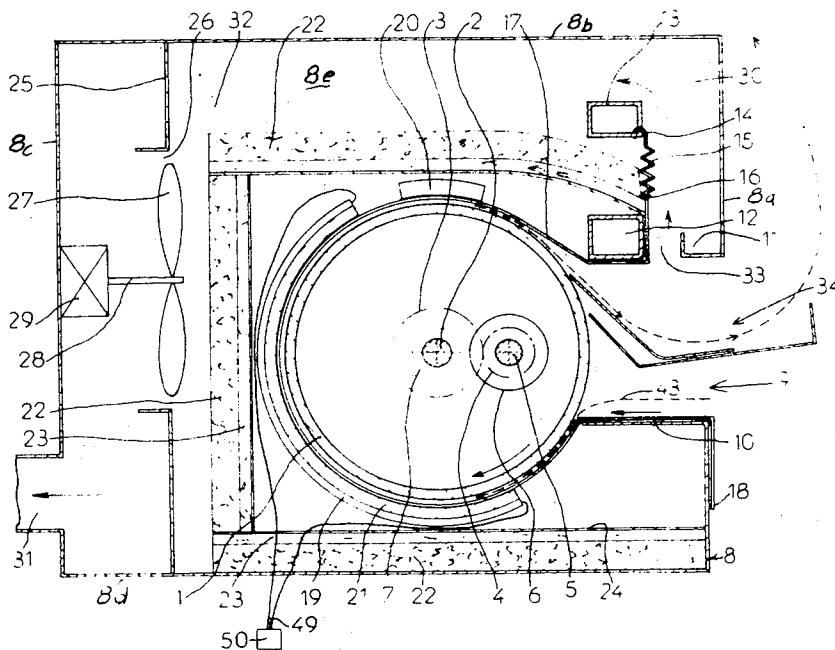

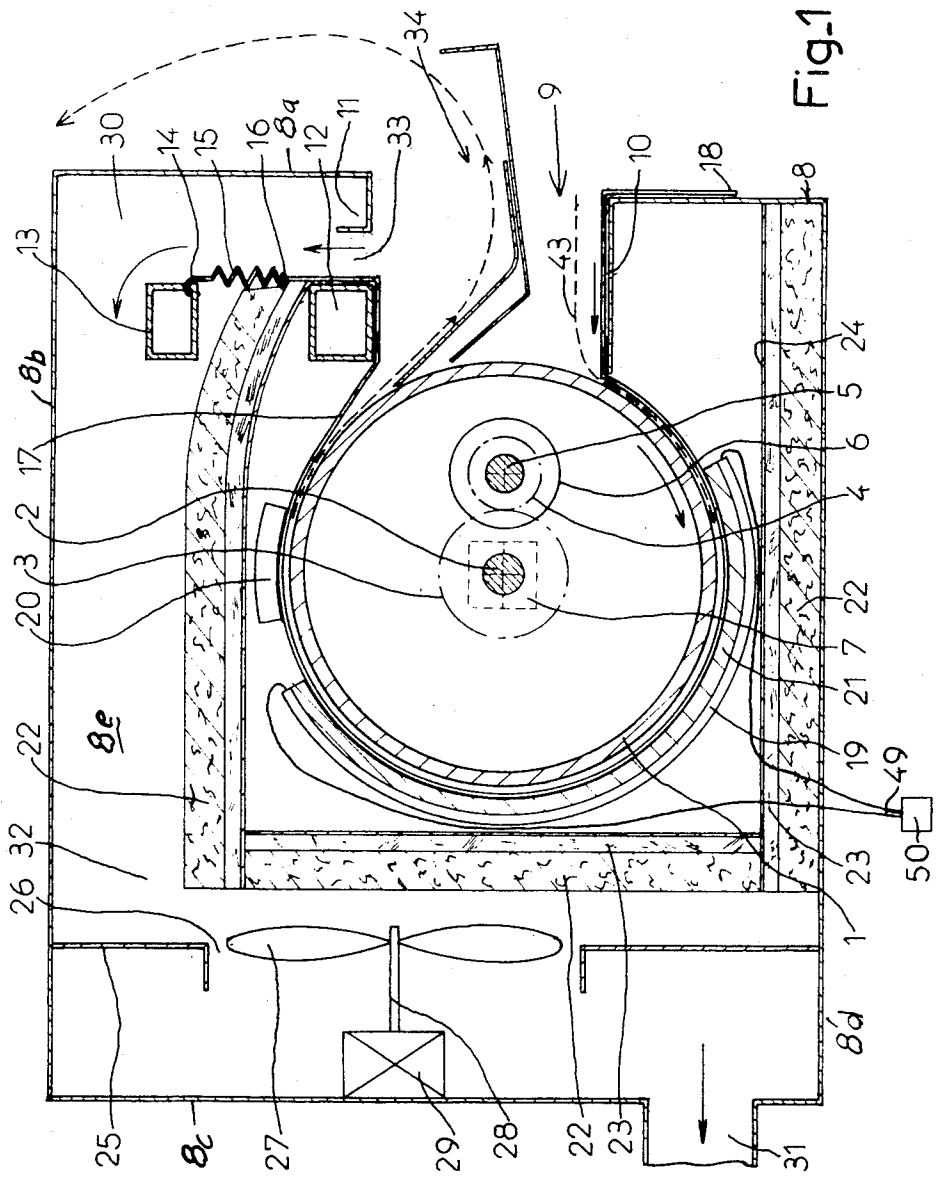

Fig. 1

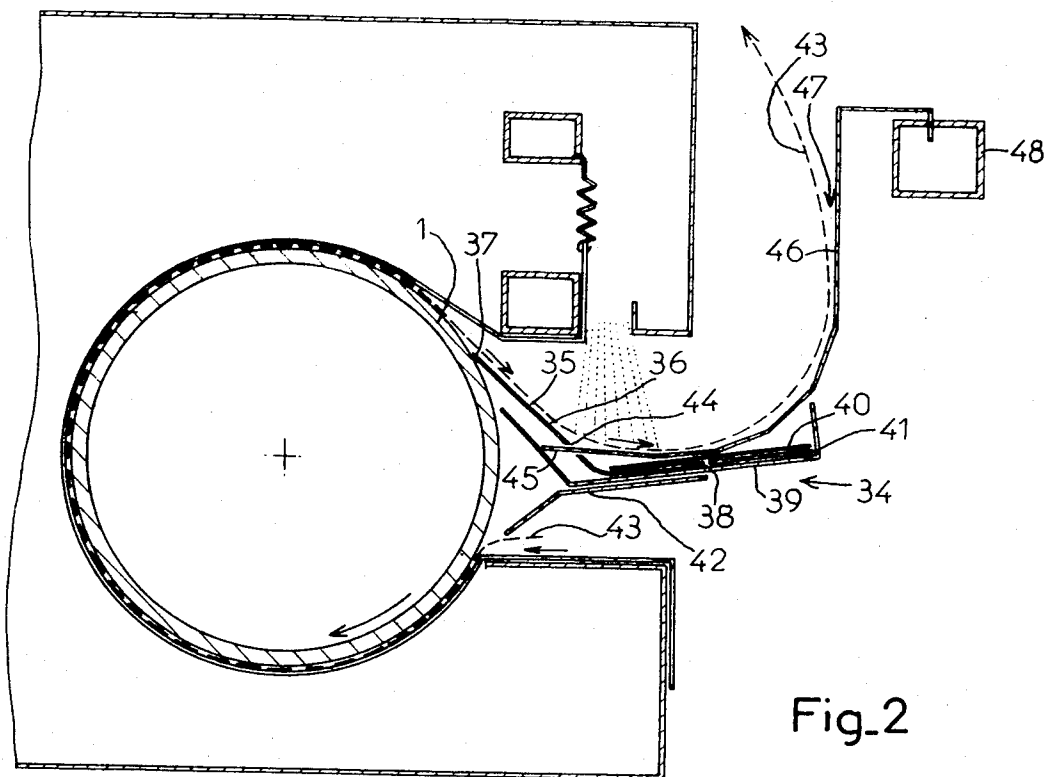

Fig. 2

## APPARATUS FOR THERMIC DEVELOPMENT OF HEAT-SENSITIVE PAPER

The invention relates to apparatus for thermic development of heliographic paper and diazo copies. For convenience, the material being developed is herein referred to as paper but it will be understood that it may be other support material.

At present, a number of different apparatuses are available for thermic development of heat-sensitive paper. In general, the paper to be developed is passed between a drum and a fabric curtain while being exposed to heat which is transmitted to the drum or to the curtain by radiation with the result that the heat exchange is neither immediate nor total. It is hence necessary to provide a heat substantially greater than that which is effectively necessary for the development. In such apparatus a probe is used to verify the temperature, but taking into account the principles of heating, there is necessarily a substantial lag between the moment when overheating occurs and that when the detecting means gives the necessary instructions for rectification. Moreover, the diameter of the drums heretofore utilized has generally been quite small so that in order to obtain a sufficiently long exposure to the heat, the speed of the development has been very slow. To facilitate the removal of the paper from the drum when the latter is rotated, there is placed on a generatrix of the drum a scrapper comprising profiled sheet metal generally associated with a support by means of an adhesive band which unfortunately resists very badly the heat which is transmitted to it by conduction. In other apparatus the scrapper is mechanically fixed to a support with the result that deformation occurs by reason of the different coefficients of expansion of the scrapper and its support.

An object of the present invention is to avoid these disadvantages and provide improved apparatus for the thermic development of heat-sensitive material comprising, on the one hand, a rotating drum enveloped by a stationary fabric curtain between which the paper to be developed is passed and, on the other hand, a controlled heat source in the form of a thin sheet which is formed so as to be applied intimately, directly and exteriorly to at least one of the supports for the paper, that is to say, the drum and the fabric curtain. Moreover, improved means is provided for sensing and controlling the temperature to which the paper is subjected.

The nature, objects and advantages of the invention will be more fully understood from the following description of a preferred embodiment shown by way of example in the accompanying drawings in which:

FIG. 1 is a vertical cross section of apparatus for the thermic development of heat-sensitive material and,

FIG. 2 is a schematic cross sectional view illustrating a preferred construction of a scrapper for extraction of the developed paper.

The apparatus shown by way of example in the drawings comprises a cylinder or drum 1 fixed on a shaft 2, on one end of which is keyed a gear 3 engaging with a pinion 4 keyed on the shaft 5 of a motor 6 which drives the cylinder 1 in rotation in the direction indicated by the arrow i.e., clockwise as viewed in FIG. 1.

The cylinder or drum 1 is carried by bearings 7 provided in the ends of a casing or housing 8 formed of sheet metal or other suitable material. The casing is shown in the form of a rectangular box having a front

wall 8a, a top 8b, a back 8c, a bottom 8d and opposite ends 8e. In the front of the casing there is a window or opening 9 providing a passage for the entry and discharge of the paper to be developed. The lower boundary of the opening is in the form of a flat, horizontal table 10 which extends into the proximity of the periphery of the drum 1. The upper boundary of the opening 9 is defined by an edge portion 11 which is turned inwardly and then upwardly.

Spaced rearwardly of the upper edge 11 of the opening 9 there is provided a cross piece 12 which is parallel to the axis of the cylinder. Above the cross piece 12 there is likewise provided a beam 13 which is provided with anchoring means 14 for one end of each of a plurality of springs 15 of which the other ends are engaged in eyelets 16 provided in one end of a fabric curtain 17. The fabric curtain extends down in front of and under the cross piece 12 and then passes around the drum 1 so as to envelop a major portion of its exterior surface. The opposite end portion of the curtain extends out over the table 10 and is fixed at its extremity 18 to the front of the casing 8. The springs 15 hold the fabric curtain under tension so that it conforms closely to the outer surface of the drum 1.

To the fabric curtain 17 there is applied a heat source 19 and a heat regulator 20. The heat source extends at least approximately halfway around the drum from a point near the entry of the paper. The heat regulator 20 is located just downstream of the heat source 19.

The drum 1 preferably has a diameter of the order of 150 to 160 millimeters. The utilization of a large diameter drum permits prolonging the contact of the paper with the drum while being heated despite relatively high speed of rotation of the drum and permits at the same time a development at a lower temperature without risk of overheating or dilation of the paper. This technical characteristic is particularly advantageous in that it permits the treatment of paper of the type referred to in French as "contre calque vernis et polyester" and moreover, the thermic refeeding for long printings with great precision. With the apparatus of the invention a speed of printing of 200 meters per hour has been obtained.

The drum is made of a material offering the best results from the point of view of heating, such for example as aluminum. It can moreover be made of other material, for example stainless steel, synthetic material, heat resistant glass etc.

The fabric 17 for pressing the paper against the drum is either a single piece or a plurality of bands which are juxtaposed and partially superposed to assure tightness. It is preferably made of a heat resistant material such as fibers of "teflon" or of glass. The fabric is preferably heat conducting but electrically insulating.

The heat source 19 is a thin sheet applied to the exterior of the cylinder on the fabric 17 to which it conforms and to which it may be bonded. The sheet is formed of conductive material, for example graphite, ferronickel or nickel silver, having suitable electrical resistance bonded by a heat resistant synthetic material, for example an acrylic resin. The sheet thus forms an electrical resistance connected in a heating circuit comprising conductors 49 connected to a source of electric current 50 under control of the heat sensing means 20. By reason of this heat source being applied directly on the fabric 17 in contact with the paper to be

developed the inertia and heat loss of the thermal transmission through air is eliminated.

In the apparatus shown by way of example in the drawings, the thin heating sheet 19 is provided on its inner surface with an additional sheet 21 which is relatively rigid and formed for example of aluminum. This additional sheet 21 is bonded on the thin heating sheet 19 but does not adhere to the fabric 17 on which it is simply applied. The bonding of the sheet 21 to the thin heating sheet 19 includes a layer which is electrically insulating but heat conductive so that the sheet 21 is electrically isolated from the heating sheet 19 but in good heat-conduction relation thereto. By virtue of this additional rigid sheet 21 there is no danger of any local heating such as that caused by excess thickness of the paper to be developed. Moreover, the rigidity of the thin intermediate sheet 21 prevents all deformation of the fabric. The absence of adhesive bonding of the rigid sheet 21 on the fabric 17 provides the advantage of permitting the replacement of the fabric 17 without replacing the heating resistance 19 and vice versa.

As a variation, the heat source is applied to the exterior of the cylinder or is incorporated therein. In this event by reason of rotation of the cylinder the electrical connections with the resistance element is effected by means of suitable slip rings and brushes.

The system of temperature regulation 20 comprises a bulb containing a vaporizable or expansible fluid connected with a regulator responsive to fluid pressure, for example the pressure of the vapor. This bulb is disposed on a stationary part of the apparatus, that is to say, the fabric 17. It has a slightly curved form with a radius of curvature identical with that of the fabric 17 permitting its direct application to a very large surface of the fabric. It thereby obtains a very high precision control permitting in effect the detection of variations of the order of one or two degrees centigrade. Control of the current by the fluid or vapor pressure in the bulb is effected by suitable mechanical means or by an electronic unit connected in the circuit of the heating element and comprising a transducer for converting pressure variations into electrical signals.

In order to avoid the loss of heat, the drum is housed in an insulating compartment comprising panels 22 of glass wall disposed above, behind and under the drum. The panels 22 are held in place by rigid insulating plates 23 formed, for example, of asbestos of which the surface facing the drum can advantageously be covered by aluminum foil 24 which reflects heat rays given off by the drum.

At the rear of the casing 8 there is a vertical partition 25 pierced by a circular orifice 26 in the plane of which there is a fan or impeller 27 fixed on the shaft 28 of a motor 29 which rotates the fan in a direction to create in the part 30 of the casing 8 situated in front of the partition 25 an aspiration of air which is discharged through a duct 31. Air is thus drawn through the space between the upper insulating panel 22 and the top 8b of the casing and between the rear panel 22 and the partition 25. The air is drawn in through an opening 33 between the cross piece 12 and the inturnd upper edge 11 of the opening 9 thereby creating a suction which acts upwardly on the paper as it is discharged from the drum.

The front and top of the casing 8 are cooled by the flow of air thus produced.

Removal of the paper from the drum is assisted by a scrapper 34 which is illustrated in more detail in FIG. 2. The scrapper 34 comprises a plate 35 of which one wing 36 is essentially tangential to the upper front part of the cylinder 1 which is grazed by the edge 37 of the wing 36 so as to remove the paper from the drum. The other wing 38 of the plate 35 is clamped between a base plate 39 and an upper plate 40 by the interposition of an elongated, thin wedge 41.

A guide 42 fixed beneath the base plate 39 and having a down-turned wing portion guides the paper 43 entering the apparatus into correct engagement between the drum and the fabric curtain 17.

The lower ends 45 of a plurality of guide wires 46 extend through holes 44 provided in the wing 36 of the plate 35 but abut an upturned inner edge portion of the base plate 39. The guide wires 46 are regularly spaced apart and are judiciously bent to form a vertical portion 47 guiding the paper 43 as it leaves the apparatus, the upper end portions of the wires 46 being bent forwardly and downwardly and fixed to a cross bar 48.

The suction created by the fan 27 drawing air over the paper as it rests on the guide wires 46 permits the elimination of the odor of the chemical reagents of the paper as well as the elimination of the effects of condensation. Moreover, this mode of realization of the scrapper eliminates all possibility of the paper hanging up on the fixed plates of the scrapper.

It is evident that the invention is in no way limited to the embodiment herein described and illustrated in the drawings as other modes of realization will be obvious to those skilled in the art.

What I claim and desire to secure by Letters Patent is:

1. Apparatus for the thermic development of heat sensitive paper comprising an outer casing, a heat insulated compartment disposed in said casing, a drum rotatably mounted in said compartment, means for rotating said drum, means defining an elongated opening in one side of said compartment providing access to the periphery of said drum, said opening having opposite edges, a flexible curtain of heat conducting material having opposite ends, said curtain having one of said ends fixedly secured at a first edge of said opening and extending around the drum in the direction of its rotation to the second edge of said opening, means at the second edge of said opening for applying tension to the other end of said curtain to maintain said curtain taut around the drum, such paper to be developed being fed between said curtain and said drum at the first edge of said opening, carried around by the rotating drum and discharged at the second edge of said opening, means for applying heat to such paper comprising a thin heating sheet of resistive electrically conductive material conforming to the curvature of said curtain extending around the drum and in contact with said curtain throughout substantially its entire width and through a circumferential extent at least approximately equal to half the circumference of said drum, and means for controlling the temperature to which such paper is heated, said casing and compartment defining a passageway extending over said compartment and opening in front of and above said opening of said compartment, and suction means for drawing air through said passageway to draw off vapors from the discharged developed paper and to cool said casing.

5

6

2. Apparatus according to claim 1, in which said heating sheet is bonded to the outer face of said curtain.

3. Apparatus according to claim 1, in which said heating sheet is bonded to a relatively rigid intermediate sheet of heat conductive material which is applied to but not bonded to said curtain.

4. Apparatus according to claim 3, in which said intermediate sheet is aluminum.

5. Apparatus according to claim 1, in which said heating sheet comprises particles of electrically conductive resistance material bonded by a heat resistant synthetic material.

6. Apparatus according to claim 1, in which said temperature control means comprises a heat sensing unit directly in contact with said flexible curtain downstream of said heating element, said sensing unit having a surface concavely curved to conform to the curvature of said curtain engaged by said sensing unit.

7. Apparatus according to claim 6, in which said heat sensing unit comprises a bulb containing a fluid having a high coefficient of expansion.

8. Apparatus according to claim 1, in which said drum has a diameter not less than 150 millimeters.

9. Apparatus according to claim 1, in which said curtain extends out over said second edge of said opening and in which said means for applying tension to said curtain comprises a plurality of tension springs acting between said other end of said curtain and a fixed support disposed above said opening.

10. Apparatus according to claim 1, in which said curtain comprises a fabric of heat resisting, heat conducting and electrically insulating material.

11. Apparatus for the thermic development of heat sensitive paper comprising a heat insulating compartment, a drum rotatably mounted in said compartment,

means for rotating said drum, means defining an elongate opening in one side of said compartment providing access to the periphery of said drum, said opening having opposite edges, a flexible curtain of heat conducting material having opposite ends, said curtain having one of said ends fixedly secured at a first edge of said opening and extending around the drum in the direction of its rotation to the second edge of said opening, means at the second edge of said opening for applying tension to the other end of said curtain to maintain said curtain taut around the drum, such paper to be developed being fed between said curtain and said drum at the first edge of said opening carried around by the rotating drum and discharged at the second edge of said opening, means for applying heat to such paper comprising a thin heating sheet of resistive electrically conducting material conforming to the curvature of said curtain extending around the drum and in contact with said curtain throughout substantially its entire width and through a circumferential extent equal to half the circumference of said drum, means for controlling the temperature to which such paper is heated, guide means positioned in said opening to discharge developed paper from said drum, and guide means comprising a scraper having a portion essentially tangential to and grazing said drum to remove such paper therefrom and a plurality of spaced guide wires extending forwardly from said scraper and then upwardly, said guide wires having lower ends extending into spaced holes in said scraper and upper ends fixed to a cross bar positioned above said opening, means defining a passageway opening above said guide wires and suction means for drawing air through said passageway to draw off vapors from discharged developed paper while supported by said guide wires.

\* \* \* \* \*

40

45

50

55

60

65