



(12) **United States Design Patent**
Papini

(10) **Patent No.:** **US D960,836 S**
(45) **Date of Patent:** **** Aug. 16, 2022**

(54) **WIND-POWERED GENERATOR**
(71) Applicant: **David Papini**, Reston, VA (US)
(72) Inventor: **David Papini**, Reston, VA (US)
(**) Term: **15 Years**

D801,927 S * 11/2017 Cooper, II D13/115
9,869,299 B2 1/2018 Blake et al.
D824,331 S * 7/2018 Schuenemann D13/115
D829,172 S * 9/2018 Cooper D13/115
(Continued)

(21) Appl. No.: **29/762,575**
(22) Filed: **Dec. 17, 2020**

FOREIGN PATENT DOCUMENTS
GB 249011 A 3/1926
KR 20100135058 A 12/2010
(Continued)

(51) **LOC (13) Cl.** **13-01**
(52) **U.S. Cl.**
USPC **D13/115**
(58) **Field of Classification Search**
USPC D13/101, 114, 115, 118, 122, 184, 199;
D12/344, 345; D15/1, 199, 29
CPC F03D 1/06; F03D 1/0608; F03D 1/0625;
F03D 1/0633; F03D 1/0641; F03D 3/02;
F03D 3/005; F03D 3/061; F03D 3/0409;
F03D 7/0224; F03D 7/04; F03D 7/06
See application file for complete search history.

OTHER PUBLICATIONS

Turbines. (Design—© Questel) orbit.com. [Online PDF compilation of references] 52 pgs. Print Dates Range Jun. 29, 2021-Jul. 28, 2020 [Retrieved Jan. 11, 2022].*
(Continued)

Primary Examiner — Manpreet S Matharu
Assistant Examiner — Suzanne E Tisdell
(74) *Attorney, Agent, or Firm* — MH2 Technology Law Group LLP

(56) **References Cited**

(57) **CLAIM**

The ornamental design for a wind-powered generator, as shown and described.

U.S. PATENT DOCUMENTS

4,080,100	A	3/1978	McNeese	
7,018,166	B2	3/2006	Gaskell	
D665,736	S *	8/2012	Presz, Jr.	D13/115
8,268,030	B2	9/2012	Abramov	
D671,071	S *	11/2012	Ai	D13/115
8,358,023	B2	1/2013	West	
D697,868	S *	1/2014	Rebsdorf	D13/115
8,736,098	B2	5/2014	Choi et al.	
D707,628	S *	6/2014	Guinard	D13/115
8,759,998	B2	6/2014	Gilbert	
8,829,706	B1	9/2014	Sammy	
D715,737	S *	10/2014	Cooper	D13/115
D727,264	S *	4/2015	Schmid	D13/115
D748,576	S *	2/2016	Guinard	D13/115
9,512,817	B2	12/2016	Wood	
9,664,172	B2	5/2017	Wieser	

DESCRIPTION

FIG. 1 is a perspective view of the front, left, top aspect of an outer housing of the wind-powered generator according to the ornamental design;
FIG. 2 is a front view of the outer housing of the wind-powered generator according to the ornamental design;
FIG. 3 is a rear view of the outer housing of the wind-powered generator according to the ornamental design; and,
FIG. 4 is a top side view of the outer housing of the wind-powered generator according to the ornamental design.

1 Claim, 3 Drawing Sheets

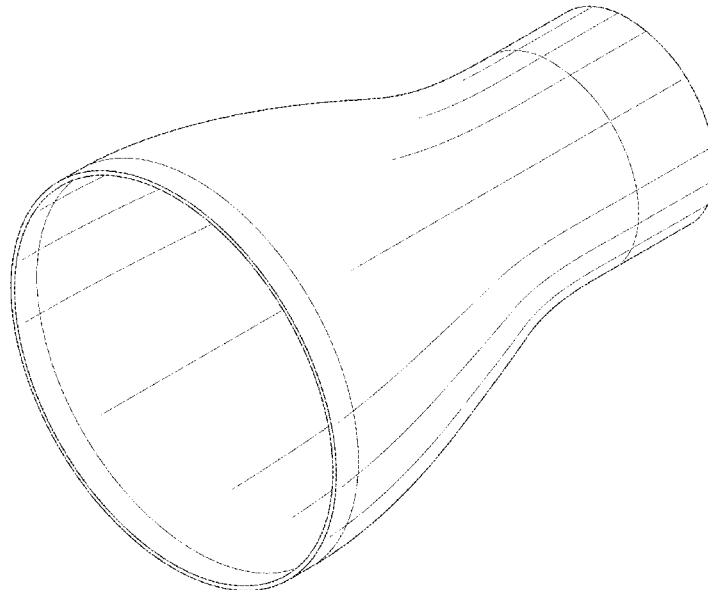

(56)

References Cited

U.S. PATENT DOCUMENTS

D869,395 S * 12/2019 Huang D13/115
D909,302 S * 2/2021 Kesby D13/115
D935,406 S * 11/2021 Geiken D13/115
2011/0305570 A1 12/2011 Shin et al.
2012/0003077 A1 1/2012 Churchill

FOREIGN PATENT DOCUMENTS

KR 101106205 B1 1/2012
KR 20120082505 A 7/2012
KR 101446106 B1 10/2014
WO 81/00286 A1 2/1981
WO 2012/159226 A1 11/2012

OTHER PUBLICATIONS

Ohya, Yuji. Schematic view of a diffuser shrouded wind turbine. Dec. 2005. Research Gate. https://www.researchgate.net/figure/Schematic-view-of-a-diffuser-shrouded-wind-turbine-a-overview-of-system-b-flow_fig1_223365637.*

Gipe, Paul. Elena Diffuser Augmented Wind Turbine. May 7, 2010. Wind-Works. http://www.wind-works.org/cms/index.php?id=672&tx_ttnews%5Btt_news%5D=147&cHash=1b8b897e4b9efe8cf827758ac9a15369.*

Change in the wind. Jan. 15, 1998. Down To Earth. <https://www.downtoearth.org.in/news/change-in-the-wind-21053>.*

* cited by examiner

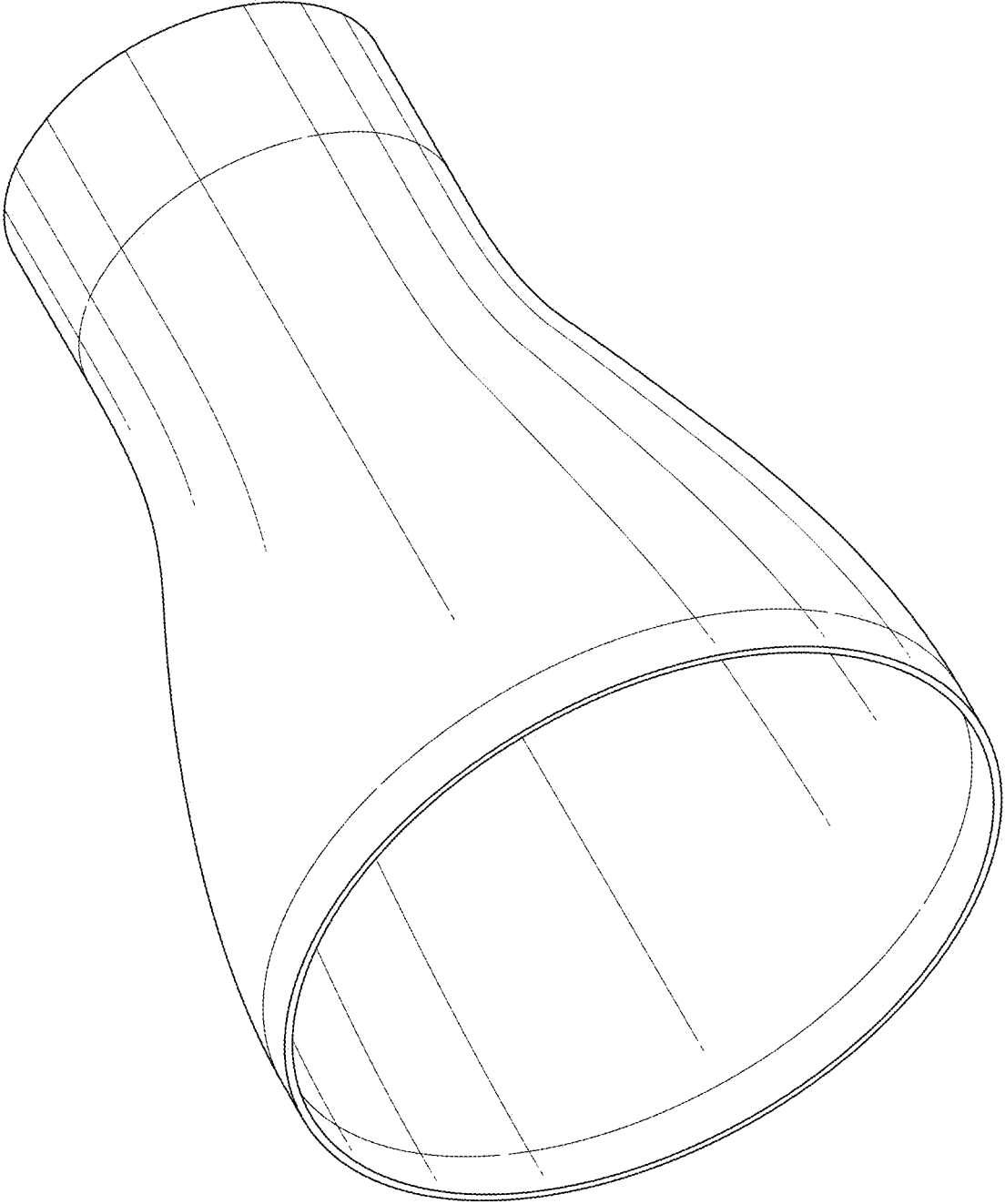

FIG. 1

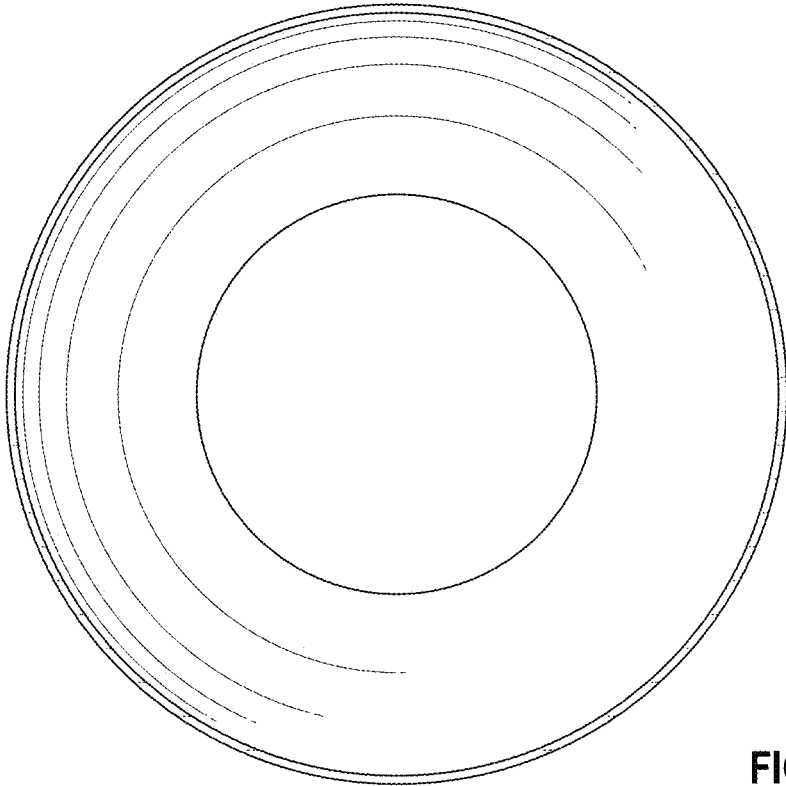

FIG. 2

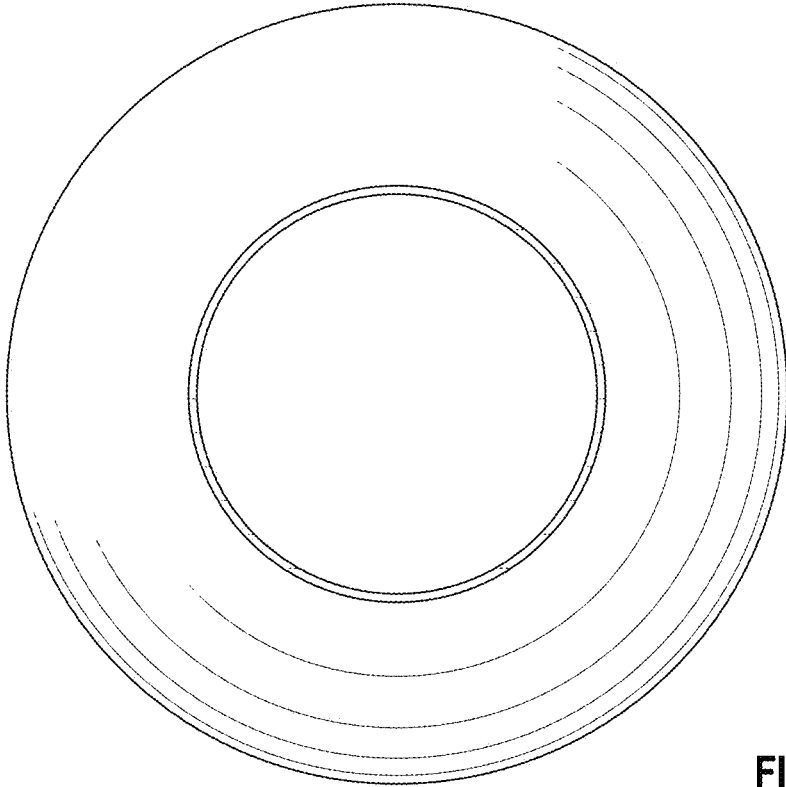

FIG. 3

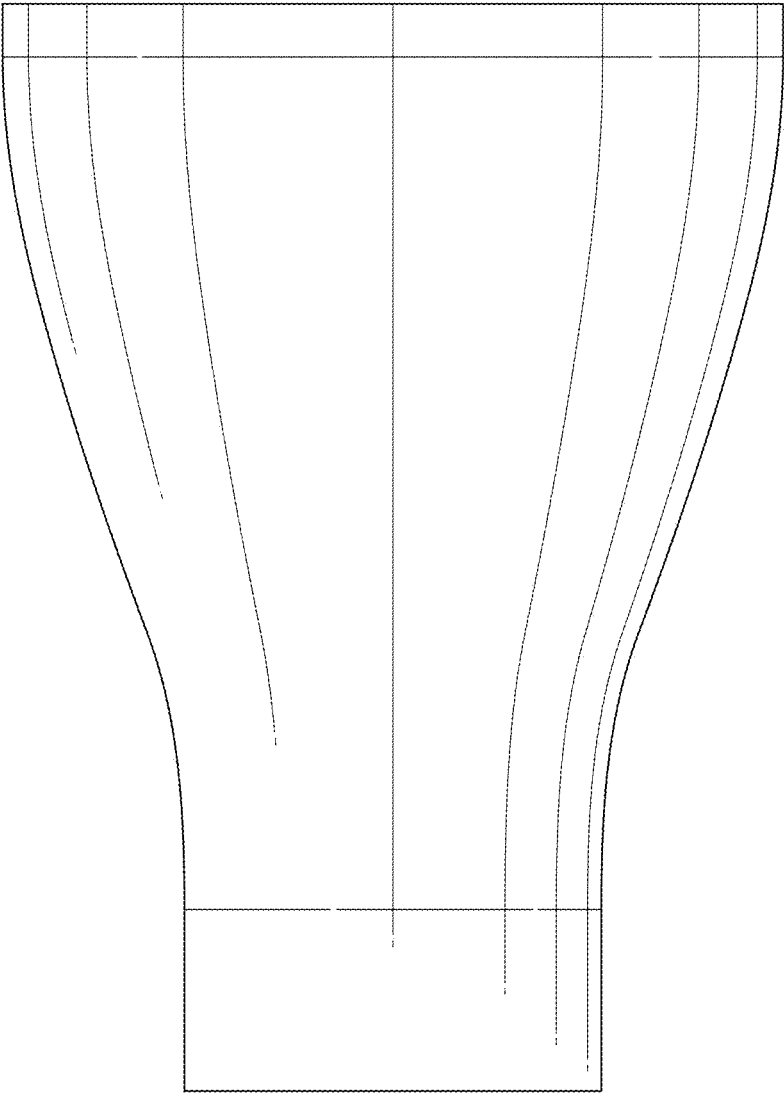

FIG. 4