

No. 765,357.

PATENTED JULY 19, 1904.

C. R. DAELLENBACH.  
TWO-CYCLE EXPLOSIVE ENGINE.

APPLICATION FILED DEC. 6, 1902.

NO MODEL.

2 SHEETS—SHEET 1.

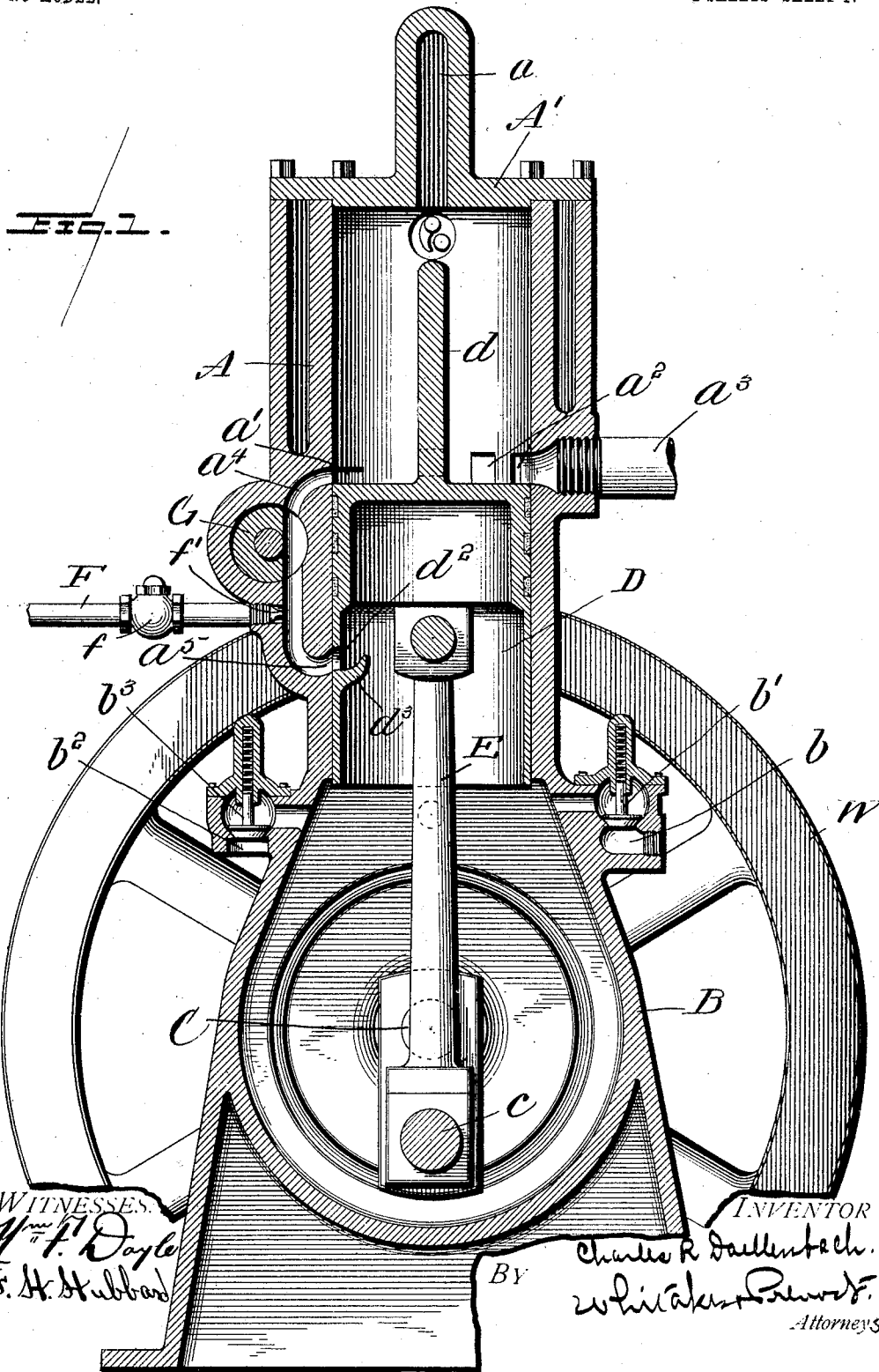

No. 765,357.

PATENTED JULY 19, 1904.

C. R. DAELLENBACH.  
TWO-CYCLE EXPLOSIVE ENGINE.

APPLICATION FILED DEC. 6, 1902.

NO MODEL.

2 SHEETS—SHEET 2.

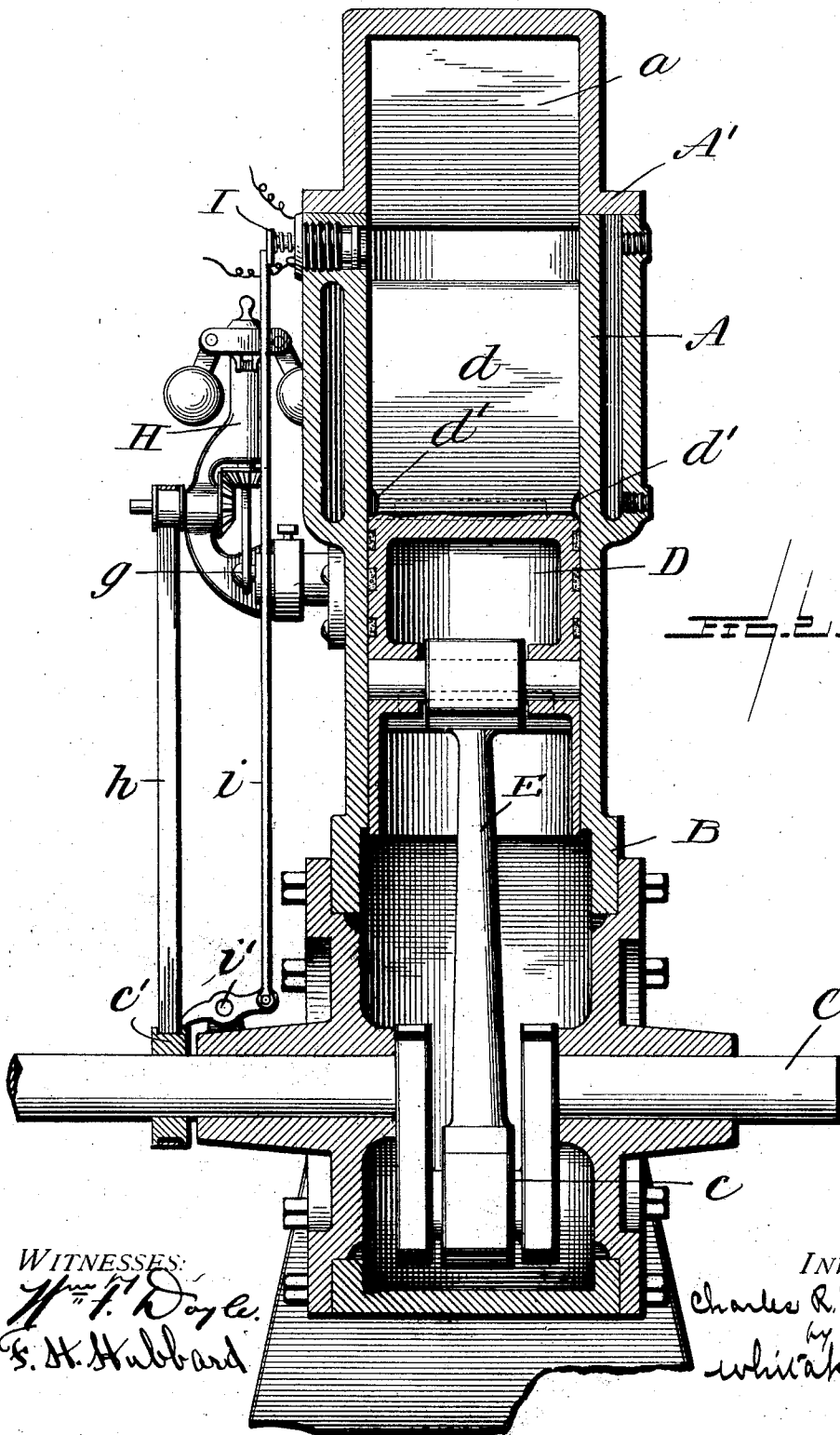

WITNESSES:  
*H. F. Doyle*  
*S. H. Hubbard*

INVENTOR  
*Charles R. Daellenbach*  
by *Whitaker & Brown*  
Attorneys

# UNITED STATES PATENT OFFICE.

CHARLES R. DAELLENBACH, OF ELLWOOD CITY, PENNSYLVANIA.

## TWO-CYCLE EXPLOSIVE-ENGINE.

SPECIFICATION forming part of Letters Patent No. 765,357, dated July 19, 1904.

Application filed December 6, 1902. Serial No. 134,189. (No model.)

*To all whom it may concern:*

Be it known that I, CHARLES R. DAELLENBACH, a citizen of the United States, residing at Ellwood City, in the county of Lawrence and State of Pennsylvania, have invented certain new and useful Improvements in Two-Cycle Explosive-Engines; and I do hereby declare the following to be a full, clear, and exact description of the invention, such as will enable others skilled in the art to which it appertains to make and use the same.

My invention consists in the novel features hereinafter described, reference being had to the accompanying drawings, which illustrate one form in which I have contemplated embodying the invention, and said invention is fully disclosed in the following description and claims.

Referring to the said drawings, Figure 1 is a vertical sectional view of a single-piston engine embodying my invention, taken in a plane transverse to the crank-shaft. Fig. 2 is a vertical sectional view of the engine shown in Fig. 1, the section being taken in a plane longitudinally of the crank-shaft.

In the drawings I have shown a single-piston rear-compression two-cycle engine embodying my invention, in which A represents the engine-cylinder, water-jacketed, as usual, and supported upon a closed hollow crank-case B, in which is mounted the crank-shaft C.

D represents the reciprocating piston, and E represents the piston-rod connecting the piston to the crank *c* of the crank-shaft C.

The piston D is provided with a partition *d*, rigidly secured to or formed integrally therewith and extending the full width of the cylinder and of substantially the length of the piston's full stroke, so that when the piston is in its lowest position, or the position farthest from the cylinder-head, said partition will extend nearly but not quite to the cylinder-head, thus dividing the cylinder into two chambers communicating over the end of said partition adjacent to the cylinder-head.

The cylinder-head A' is provided with a recess or pocket into which the partition slides when the piston is moved toward the said

head, and the said partition *d* is preferably provided adjacent to the piston at one or both edges with notches or recesses *d'* *d''*, as shown in Fig. 2, for a purpose hereinafter described.

The cylinder A is provided with an inlet-port *a'*, located on one side of the partition *d*, and an exhaust-port or series of ports *a''*, located on the opposite side of said partition, the latter ports being of greater width longitudinally of the cylinder than the inlet or admission port, so that the exhaust port or ports will have a lead over and will open before and close after the inlet-ports, it being understood that the inlet and exhaust ports are opened and closed by the piston during its reciprocations. The exhaust port or ports *a''* communicate with an exhaust opening or pipe *a'''*, as shown.

The cylinder A is provided with a passage *a<sup>4</sup>*, extending from the inlet-port *a'* to an aperture *a<sup>5</sup>* in the wall of the cylinder beyond the piston-head when the latter is in its position farthest from the cylinder-head, at which time said aperture registers with an aperture *a<sup>6</sup>* in the piston, as shown in Fig. 1. The interior of the piston is provided with an inwardly and upwardly curved deflector or lip *a<sup>7</sup>* below and adjacent to the aperture *a<sup>6</sup>*.

The closed crank-case B is provided with an inlet-aperture *b* for the admission of gas, controlled by a check-valve *b'*, and a separate air-inlet *b<sup>2</sup>*, controlled by a check-valve *b<sup>3</sup>*. When hydrocarbon liquid is used as the fuel, the said liquid is preferably introduced into the passage *a<sup>4</sup>*, as by means of a pipe F, provided with a check-valve *f* and a nozzle *f'* to spray the liquid into the air during the suction-stroke of the piston, the gas-inlet *b* being of course closed or left open to the atmosphere, as preferred, when a liquid hydrocarbon is used.

G represents a regulating-valve located in the passage *a<sup>4</sup>* and adapted to be controlled by a centrifugal governor H. (See Fig. 2.) In this instance the governor, which may be of any usual or preferred construction, is driven by a belt *h* from a pulley *c'* on the crank-shaft, and the stem of the governor is con-

nected to a crank-pin  $g$  on the valve  $G$  for the purpose of rotating said valve to regulate the passage of explosive mixture through passage  $a^4$ .

5 I represents the igniter, which is located in line with the partition  $d$  of the piston and at such a position that when the piston is in the position nearest the head of the cylinder the igniter will be opposite one of the recesses  $d'$  in said partition  $d$ . I may employ either a  
10 hot tube, incandescent jump-spark, or other preferred form of igniter; but I have shown in the drawings an igniter of the jump-spark, the movable contact of which is connected by  
15 an igniter-rod  $i$  with a tappet-lever  $z'$ , actuated by a cam on the pulley  $c'$ .

W represents the fly or balance wheel of the engine. This engine operates on the two-cycle system, and its cycle of operation may be  
20 traced as follows, supposing a mixture of gas and air to be used:

During the downstroke of the piston the latter is moving under the pressure of the exploded or burned gases in the cylinder, and  
25 as the piston moves down (or away from the cylinder-head) and approaches the end of its stroke it will uncover the exhaust-port, thus allowing the burned gases on both sides of the partition to partially escape through the ex-  
30 haust pipe or passage until the pressure within the cylinder is reduced to substantially that of the atmosphere. During the working stroke the explosive mixture of gas and air previously admitted through the apertures  $b$   $b^2$   
35 will be compressed.

The further downward movement of the piston uncovers the inlet-port  $a'$ , and at the same time the apertures  $a^5$   $d^2$  on the other side of the piston-head are made to register. The  
40 compressed mixture in the crank-case rushes through passage  $a^4$  and inlet-port  $a'$  into the lower part of the cylinder on one side of the partition  $d$ , and as it enters the cylinder it forces the exploded gases up over the parti-  
45 tion  $D$  and following down on the other side of the piston expels them practically entirely from the cylinder, the fresh explosive mixture expanding in the cylinder to substantially atmospheric pressure. As the piston  
50 starts on the return stroke it first closes the inlet-port  $a'$  (and the aperture  $a^5$ ) and then the exhaust-port, thus insuring the expulsion of practically all the exploded gases, and as it approaches the cylinder-head, acting under the  
55 momentum of the balance-wheel, the fresh explosive charge is compressed on both sides of the partition  $d$  equally, the recesses  $d'$  permitting this equalization of pressure. During the return stroke of the piston the suction  
60 thereof on its lower side draws in air and gas through apertures  $b$  and  $b^2$ , the proportions of which will be regulated by suitable cocks. (Not shown.)

When the piston has reached its highest  
65 point, or the point nearest the cylinder-head,

the charge is ignited, ignition taking place on each side of the partition  $d$  simultaneously, owing to the location of the igniter in the path of the recessed portion of the partition, and the working stroke will follow, as pre-  
70 viously described.

It will be noted that in the operation of this engine every second stroke is a working stroke, and the cylinder is swept free of ex-  
75 ploded gases at the conclusion of each working stroke.

I do not limit myself to the application of this invention to engines of the rear-compression type, where the charge is compressed in the crank-case, as it is perfectly obvious that  
80 the air and gas or mixture could be compressed by other means and delivered to the inlet-port with substantially the same result. In other ways I do not desire to be limited to the exact details of construction herein shown  
85 and described, as variations may be made therein without departing from the spirit of my invention. It is also obvious that my invention may be applied to engines provided with two or more cylinders.  
90

What I claim, and desire to secure by Letters Patent, is—

1. In an explosive-engine, the combination with a cylinder, of a piston provided with a transverse partition extending perpendicu-  
95 larly therefrom and substantially the same length as the stroke of the piston, and a cylinder-head provided with a perpendicular recess of substantially the length of the piston-stroke to receive and closely fit the said parti-  
100 tion for substantially its entire length, whereby said partition divides the cylinder into two parts, the construction being such that said parts are in communication by a small aperture only at the end of the outstroke of the  
105 piston substantially as described.

2. In an explosive-engine, the combination with the cylinder, of a piston therein provided with a transverse partition extending perpendicularly therefrom and of substantially the  
110 length of the piston-stroke, said cylinder having its head provided with a perpendicular recess to receive and closely fit said partition throughout substantially its entire length, whereby the partition divides the cylinder  
115 into two parts, the construction being such that said two parts of the cylinder are in communication by a small aperture only at the end of the outstroke of the piston, said cylinder having an inlet-port on one side of the  
120 partition and an exhaust-port on the other side of the partition, substantially as described.

3. In an explosive-engine, the combination with the cylinder, of a piston therein provided with a transverse partition extending perpen-  
125 dicularly therefrom and of substantially the length of the piston-stroke, said cylinder having its head provided with a perpendicular recess to receive and closely fit said partition throughout substantially its entire length,  
130

whereby the partition divides the cylinder into two parts, the construction being such that said two parts of the cylinder are in communication by a small aperture only at the end of the outstroke of the piston, said cylinder having an inlet-port on one side of the partition and an exhaust-port on the other side of the partition, said exhaust-port being given a lead over the inlet-port, substantially as described.

4. In an explosive-engine, the combination with a cylinder, of a piston in said cylinder provided with a transverse partition extending perpendicularly therefrom, said cylinder being provided with a head having a recess to receive said partition, and with an inlet-port and an exhaust-port on opposite sides of said partition, said partition being provided with a pressure-equalizing aperture therein, substantially as described.

5. In an explosive-engine, the combination with a cylinder, of a piston in said cylinder provided with a transverse partition extending perpendicularly therefrom, said cylinder being provided with a head having a recess to receive said partition, and with an inlet-port and an exhaust-port on opposite sides of said partition, said partition being provided adjacent to one edge with a pressure-equalizing recess and an igniter located adjacent to the travel of said recessed portion of said partition, substantially as described.

6. In an explosive-engine, the combination with a cylinder, of a piston therein provided with a transverse partition extending perpendicularly therefrom and substantially the length of the piston-stroke, said cylinder being provided with a head having a recess to receive and closely fit said partition throughout its length, whereby the partition divides the cylinder into two parts, the construction being such that said parts are in communication by a small aperture only at the end of the outstroke of the piston, said cylinder having an inlet-port and an exhaust-port located on opposite sides of said partition, a closed crank-case connected with the cylinder and provided with an inlet, a valve controlling said inlet, a connection between said crank-case and said

inlet-port, and means for admitting combustible material to said crank-case, substantially as described.

7. In an explosive-engine, the combination with a cylinder, of a piston therein provided with a transverse partition extending perpendicularly therefrom and substantially the length of the piston-stroke, said cylinder being provided with a head having a recess to receive and closely fit said partition throughout its length, whereby the partition divides the cylinder into two parts, the construction being such that said parts are in communication by a small aperture only at the end of the outstroke of the piston, said cylinder having an inlet-port and an exhaust-port located on opposite sides of said partition, the exhaust-port being given a lead over the inlet-port, a closed crank-case connected with the cylinder and provided with an inlet, a valve controlling said inlet, a connection between said crank-case and said inlet-port, and means for admitting combustible material to said crank-case, substantially as described.

8. In an explosive-engine, the combination with a cylinder, of a piston in said cylinder provided with a transverse partition extending perpendicularly therefrom, said cylinder being provided with a head having a recess to receive said partition, and with an inlet-port and an exhaust-port on opposite sides of said partition, said partition being provided adjacent to one edge with a pressure-equalizing recess and an igniter located adjacent to the travel of said recessed portion of said partition, said exhaust-port being given a lead over the inlet-port, a closed crank-case, provided with an air-inlet and an inlet for explosive material, suction-operated valves controlling said inlets and a connection between said crank-case and the inlet-port controlled by the piston, substantially as described.

In testimony whereof I affix my signature in the presence of two witnesses.

CHARLES R. DAELLENBACH.

Witnesses:

CLARENCE A. WILLIAMS,  
G. E. TURNER.