

(19)



(11)

EP 4 194 389 B1

(12)

EUROPEAN PATENT SPECIFICATION

(45) Date of publication and mention of the grant of the patent:
22.05.2024 Bulletin 2024/21

(51) International Patent Classification (IPC):
B66D 1/36 (2006.01) B66D 1/74 (2006.01)
B66D 3/10 (2006.01)

(21) Application number: **22212372.1**

(52) Cooperative Patent Classification (CPC):
B66D 1/7415; B66D 1/36; B66D 3/10

(22) Date of filing: **08.12.2022**

(54) **A PULLEY WITH IMPROVED GUIDING OF A ROPE AND A WINCH WITH SAID PULLEY**

RIEMENSCHLEIBE MIT VERBESSERTER FÜHRUNG EINES SEILS UND WINDE MIT DIESER RIEMENSCHLEIBE

POULIE AVEC GUIDAGE AMÉLIORÉ D'UN CÂBLE ET TREUIL AVEC LADITE POULIE

(84) Designated Contracting States:
AL AT BE BG CH CY CZ DE DK EE ES FI FR GB GR HR HU IE IS IT LI LT LU LV MC ME MK MT NL NO PL PT RO RS SE SI SK SM TR

(30) Priority: **08.12.2021 SI 202100214**

(43) Date of publication of application:
14.06.2023 Bulletin 2023/24

(73) Proprietor: **Pisek - Vitli Krpan, d.o.o. 3240 Smarje pri Jelsah (SI)**

(72) Inventor: **PISEK, Franc 3240 Smarje pri Jelsah (SI)**

(74) Representative: **Patentni Biro AF d.o.o. Kotnikova 32, p.p. 2706 1001 Ljubljana (SI)**

(56) References cited:
EP-A1- 2 307 302 EP-A1- 3 066 041
SI-A- 25 044 SI-A- 25 661

EP 4 194 389 B1

Note: Within nine months of the publication of the mention of the grant of the European patent in the European Patent Bulletin, any person may give notice to the European Patent Office of opposition to that patent, in accordance with the Implementing Regulations. Notice of opposition shall not be deemed to have been filed until the opposition fee has been paid. (Art. 99(1) European Patent Convention).

Description

Field of the invention

[0001] The present invention belongs to the field of forestry winches, more precisely to the field of constructional details of winches, particularly related to the upper pulley with an unwinding device. The invention relates to a pulley with improved guiding of a rope and a winch with said pulley.

Background of the invention and the technical problem

[0002] Forestry winches are usually provided with an upper and lower pulley, via which a wire rope is wound on a drum, thus pulling a load towards the winch. The lower pulley is used in case the user intends to lower the centre of gravity in order to stabilize the tractor. Pulleys known up to now have unwinding discs (discs), which are supposed to prevent or at least limit the rope from disengaging, i.e., falling out or derailing, of the pulley in the area between the rope and the guide or the entrance for the rope. Said unwinding discs are installed on the housing of the upper pulley, which often does not prevent the rope from falling out. Namely, the upper pulley moves in the vertical axis by about 180°, while the wire rope guide moves in the horizontal axis for about 115°, and because of this difference, the wire rope may disengage between the unwinding discs and the wire rope guide. This problem is particularly emphasized in cases the wire guide is facing downwards during unwinding, for example, when the wire rope is led via the lower pulley. Since the distance and angle between the unwinding discs and the wire rope guide are large, it often occurs that the wire rope between the unwinding discs and the wire rope guide disengages, and in extreme cases becomes entangled.

[0003] The probability of such an event is increased if the rope is damaged. In case the user initiates pulling and does not notice the dislocated or entangled rope, the wire rope may be damaged or broken or parts of the winch may be damaged. Since the winch user may not notice that the wire rope has come out of the pulley, especially when the wire rope is continuously unwinding, it is therefore desirable that the pulley is arranged for suitable rope guiding that should prevent rope disengagement. Existing solutions include various flexible covers and bolts that are exposed during work and are quickly damaged or stuck.

[0004] The technical problem, which is solved by the present invention, is efficient prevention of disengagement of the wire rope between the unwinding discs and the guide of the wire rope, particularly in case load pulling is performed via the lower pulley for ensuring better stability.

Prior art

[0005] Patent SI22855 describes a device for controlled winding and unwinding of a wire via a pulley, wherein the spatial or the 3D adjustment of the wire rope running via the pulley is achieved with an oscillating support with guide-push rollers pushed by two springs adjustable with screws of the oscillating support. Said support is installed on the housing of the pulley, while during movement of the guided rope still allows creation of a gap, where the rope may disengage.

[0006] Patent SI25044 describes a pulley comprising a fixed housing and a movable housing with a rope guide, wherein the pulley is further equipped with a limiter of the wire rope that has a rod guided in a groove of the right and left side of the fixed housing. The rod is controlled with a curve mounted in a fixed manner on the right and left side of the movable housing. Contact of the rod with the groove and the curve is in the area of smallest risk to the highest risk of disengagement of the wire rope before the rope guide. The curve is shaped is formed with a lower height in the area of increased risk and after a continuous transition to a higher height in the area of reduced risk. The curve has a hook formed at each end for forced movement of the rod and the lower height of the curve allows the passage of the rod in the groove, the higher height of the curve prevents this. However, said limiter during movement of the movable housing with the rope guide in the downwards direction still leaves a gap, where the rope may disengage, which is also visible from the figures of this document. This solution therefore does not address the problem in a reliable manner.

[0007] Patent SI25661 relates to a forestry winch with improved protection during guiding the towing rope in the area of the upper pulley. Said pulley is provided with a wire rope guide, which comprises a guide bush, through which the wire rope is led. Said guide bush is mounted on a pair of arms arranged on each side of said sheave and is together with the guide bush rotatable for a defined angle relative to the housing of the upper pulley around a horizontal geometric axis, around which said sheave is also rotatable. In the area between the housing of the upper pulley near the sheave and the wire guide, a rope guard is installed to close at least partially the gap in the circumferential direction of the sheave between the housing and the rope guide. The guard consists of two linked parts, wherein the first part is connected to the housing and the second is connected to the rope guide. During movement of the rope guide, the guard extends or folds into a vertical position, which partially protects against rope disengagement. However, a gap between the guard and the entry of the rope guide is still possible, which is particularly observable if the rope guide is facing downwards.

[0008] Patent application EP3066041 describes a forestry winch is improved in such manner that a supporting roller member on the upper pulley block is mounted pivotally around an axis of rotation of a pulley in the upper

pulley block, however independently on rotation of said pulley, and is moreover adapted to cooperate with a section of a towing cable, which extends towards a winding drum.

[0009] The described known solutions do not solve the technical problem, when the rope is entering from below and the guide of the rope is facing downwards. The construction according to the present invention solves this problem and therefore differs from the above-described solutions.

Description of the solution to the technical problem

[0010] The technical problem is solved as defined in the independent claim, while preferred embodiments are defined in dependent claims.

[0011] The pulley with improved guiding of the wire rope, which efficiently prevents disengagement (falling out) of the rope from the pulley in all positions of the latter, comprises a fixed housing, which is in a vertical axis rotatably mounted on a housing of a winch in any known manner, and a movable rope guide, which is movably mounted in the fixed housing, as well as a sheave along which the rope is led, wherein the pulley is further provided with an adjustable pushing mechanism, which is movably mounted on the housing of the rope guide. The pushing mechanism is installed in a manner that allows its movement at the time of movement of the housing of the rope guide, thus ensuring a constant distance between the pushing mechanism and the rope guide. This efficiently prevents the rope from disengaging from the pulley. Due to the assembly of the pushing mechanism and its mounted the position of the rope in the area tangential to the sheave, which is optimal for reliable guiding of the rope.

[0012] Known solutions thus differ from the present invention in that their construction does not enable that the guard or limiter moves together with the rope guide, while the essence of the present invention is that the distance between the pushing mechanism and the rope guide does not change and thus in all positions of the rope guide prevents rope disengagement between the unwinding device and the wire rope guide.

[0013] The pushing mechanism may be designed in any suitable manner, preferably it is designed as a holder with an interior, where at least one, preferably two or more, optimally two leading-pushing discs are installed. The leading-pushing discs may be freely rotatable or driven. In case of the latter, all discs may be driven or only one of them. The discs are preferably provided with a concave semi-circular groove arranged to receive the rope, which is led via the sheave of the pulley. Said groove is not essential, as discs without them also perform well. The disc is installed with a dowel, a bush or any other suitable element and a ball or any other bearing or any suitable element, such as a bush. The housing (holder) of the leading-pushing cylinders is preferably with screws, but also in any other manner, adjustably

mounted on the housing of the rope guide. At the same time, at least one compression spring, preferably two or more compression springs, exert pressure of the leading-pushing discs on the driven sheave. Consequently, the leading-pushing discs move together with the housing of the rope guide. Simultaneously, 3D adjustment of the driven sheave and the pushing cylinder relative to the position of the rope in the groove of the sheave and discs is ensured.

[0014] The described pulley may be installed on any winch or any other suitable device, wherein the pulley is preferably installed on a hydraulic winch.

[0015] The unwinding pulley with improved guiding of the wire rope and the winch with said unwinding pulley according to the invention will be further described based on an exemplary embodiment and figures, which show:

Figure 1a A known pulley in a position, in which a load is being pulled via a lower pulley

Figure 1b A known pulley when the wire rope disengages and a loop is formed

Figure 2 The pulley according to a possible embodiment, when the rope guide is facing downwards

Figure 3 The pulley according to a possible embodiment, when the rope guide is facing upwards

Figure 4 An explosion view of the leading-pushing mechanism

[0016] Figures 1a and 1b show a known unwinding pulley 1' comprising:

- a fixed housing 11' rotatably installable in an axis 11a to a housing of a winch,
- a movable guide 12' of a rope 2', said guide is movably mounted in the fixed housing 11',
- a sheave 13' for leading the rope 2', and
- a pushing mechanism 14' installed on the fixed housing 11' of the pulley 1', wherein said pushing mechanism 14' cannot move together with movement of the rope guide 12'.

[0017] Due to the latter, the wire rope 2' may disengage and leave the pulley 1' and in a worst-case scenario a loop is formed, as shown in figure 2. In such case, the user must be cautious or has to ensure that the rope is disentangled and straightened.

[0018] The solution of the problem as shown in figures 2 to 4 is the designed in the following manner: the pulley 1 is provided with a pushing mechanism 14, which is mounted on a movable guide 12 of the rope. Consequently, the pushing mechanism 14 moves together with the rope guide 12 along the horizontal axis and the distance between the mechanism 14 and the guide 12 of the wire rope is always the same regardless of the position of the rope guide 12. Because the main unwinding disc during unwinding rotates in the direction towards the rope guide,

it is practically impossible that the wire rope could disengage from the pulley in the area between the unwinding discs and the rope guide.

[0019] The pushing mechanism 14 according to a possible embodiment shown in figure 4 is designed as a housing or a holder 141 with an interior, where two leading-pushing discs 142 are installed. The discs 142 have a concave semi-circular groove 142a arranged to receive the wire rope 2, which runs on the sheave 13 of the pulley. Each disc 142 is installed with a dowel 143 or any other suitable element and a ball or any other bearing 144. In-between, washers 146 and retaining discs 147 are provided, as shown in figure 4. The retaining discs ensure axial protection of dowels. Alternatively, the dowels may be protected with cotter keys, spring pins, nuts, or any other similar elements. Washers ensure a physical distance between the pushing disc and the housing. The entire housing/holder 141 of the leading-pushing discs 142 is mounted with two screws 148 on the housing of the rope guide 12. Two pressure springs 145 are installed on the housing, which push the entire housing 141 towards the driven sheave. Due to the adjustable mounting and the pressure springs 145 the leading-pushing discs 142 141 adapt to the driven sheave or the wire rope, respectively. Consequently, the leading-pushing discs move together with the housing of the rope guide. Simultaneously, 3D adjustment of the drive sheave and the leading-pushing discs relative to the position of the rope in the groove of the sheave and the discs is ensured.

Claims

1. A pulley (1) with improved guiding of a wire rope, said pulley (1) comprising:
 - a housing (11), which is in a vertical axis (11a) rotatably mountable on a housing of a winch,
 - a movable guide (12) of the rope (2), said guide (12) movable mounted in the fixed housing (11) around a sheave (13) rotation axis,
 - the sheave (13) along which the rope (2) runs, and
 - a pushing mechanism (14) arranged to lead the rope (2),

characterized in that

 - the pushing mechanism (14) is mounted on the movable rope guide (12), so that the pushing mechanism (14) is synchronously movable with the rope guide (12) and the distance between the pushing mechanism (14) and the rope guide (12) is constant regardless of the position of the rope guide (12).
2. The pulley with improved guiding of the wire rope according to claim 1, wherein the pushing mechanism (14) is designed in any suitable manner, preferably it is designed as a housing (141) with an in-

terior where at least one, preferably two or more, leading-pushing discs (142) are provided.

3. The pulley with improved guiding of the wire rope according to claim 2, wherein the leading-pushing discs (142) are freely-rotatable or driven.
4. The pulley with improved guiding of the wire rope according to claim 3, wherein the leading-pushing discs (142) are driven, wherein all discs or at least one of them is driven.
5. The pulley with improved guiding of the wire rope according to claim 4, wherein each disc (142) is installed via a dowel (143), a bush or any other suitable element and a ball or any other suitable bearing (144) or an element such as a bush.
6. The pulley with improved guiding of the wire rope according to any claim from 2 to 5, wherein each disc (142) has a concave semi-circular groove (142a) arranged to receive the rope (2) that runs on the sheave (13) of the pulley.
7. The pulley with improved guiding of the wire rope according to any claim from 2 to 6, wherein the housing (141) of leading-pushing discs (142) is preferably with bolts or in any other manner adjustably mounted on the housing of the rope guide (12), and wherein above the housing (141) at least one, preferably two pressure springs (145) are mounted, said springs arranged to push the entire housing (141) towards the driven sheave (13).
8. The pulley with improved guiding of the wire rope according to any claim from 2 to 7, wherein dowels are protected with retaining discs (147), cotter keys, spring pins, nuts, or any other similar elements, wherein washers (146) ensure a physical distance between the pushing discs (142) and the housing (141).
9. A winch comprising the pulley according to any of the preceding claims.

Patentansprüche

1. Riemenscheibe (1) mit verbesserter Führung eines Drahtseils, wobei die Riemenscheibe (1) Folgendes umfasst:
 - ein Gehäuse (11), das in einer vertikalen Achse (11a) drehbar an einem Gehäuse einer Winde montierbar ist,
 - eine bewegliche Führung (12) des Seils (2), wobei die Führung (12) beweglich im festen Gehäuse (11) um eine Drehachse der Seilscheibe

- (13) montiert ist,
 - die Seilscheibe (13), entlang der das Seil (2) verläuft, und
 - einen Schubmechanismus (14), der angeordnet ist, um das Seil (2) zu führen, **dadurch gekennzeichnet, dass**
 - der Schubmechanismus (14) an der beweglichen Seilführung (12) so montiert ist, dass der Schubmechanismus (14) synchron mit der Seilführung (12) beweglich ist und der Abstand zwischen dem Schubmechanismus (14) und der Seilführung (12) unabhängig von der Position der Seilführung (12) konstant ist.
2. Riemenscheibe mit verbesserter Führung des Drahtseils nach Anspruch 1, wobei der Schubmechanismus (14) auf beliebige geeignete Weise ausgebildet ist, vorzugsweise als Gehäuse (141) mit einem Innenraum, in dem mindestens eine, vorzugsweise zwei oder mehr, Vorschubscheiben (142) vorgesehen sind.
3. Riemenscheibe mit verbesserter Führung des Drahtseils nach Anspruch 2, wobei die Vorschubscheiben (142) frei drehbar sind oder angetrieben werden.
4. Riemenscheibe mit verbesserter Führung des Drahtseils nach Anspruch 3, wobei die Vorschubscheiben (142) angetrieben werden, wobei alle Scheiben oder mindestens eine von ihnen angetrieben werden.
5. Riemenscheibe mit verbesserter Führung des Drahtseils nach Anspruch 4, wobei jede Scheibe (142) über einen Zylinderstift (143), eine Buchse oder ein anderes geeignetes Element und eine Kugel oder ein anderes geeignetes Lager (144) oder ein Element wie eine Buchse installiert ist.
6. Riemenscheibe mit verbesserter Führung des Drahtseils nach einem der Ansprüche 2 bis 5, wobei jede Scheibe (142) eine konkave halbkreisförmige Nut (142a) aufweist, die angeordnet ist, um das Seil (2) aufzunehmen, das auf der Seilscheibe (13) der Riemenscheibe läuft.
7. Riemenscheibe mit verbesserter Führung des Drahtseils nach einem der Ansprüche 2 bis 6, wobei das Gehäuse (141) der Vorschubscheiben (142) vorzugsweise mit Bolzen oder auf andere Weise verstellbar am Gehäuse der Seilführung befestigt ist (12), und wobei über dem Gehäuse (141) mindestens eine, vorzugsweise zwei Druckfedern (145) angebracht sind, wobei die Federn angeordnet sind, um das gesamte Gehäuse (141) in Richtung der angetriebenen Riemenscheibe (13) zu drücken.
8. Riemenscheibe mit verbesserter Führung des Drahtseils nach einem der Ansprüche 2 bis 7, wobei Zylinderstifte durch Haltescheiben (147), Splinte, Federstifte, Muttern oder andere ähnliche Elemente geschützt sind, wobei Unterlegscheiben (146) einen physischen Abstand zwischen den Schubscheiben (142) und dem Gehäuse (141) gewährleisten.
9. Winde, welche die Riemenscheibe nach einem der vorstehenden Ansprüche umfasst.

Revendications

1. Une poulie (1) avec guidage amélioré d'un câble et treuil avec ladite poulie (1) comprenant :
- un boîtier (11), qui est dans un axe vertical (11a), qui se monte de façon rotative sur le boîtier d'un treuil,
 - un guide mobile (12) pour le câble (2), ledit guide (12) étant monté de façon mobile dans le boîtier fixe (11) autour d'un axe de rotation du réa (13),
 - le réa (13) sur lequel le câble (2) passe, et
 - un mécanisme de poussée (14) disposé de façon à diriger le câble (2), **caractérisé par le fait que**
 - le mécanisme de poussée (14) est monté sur le guide de câble mobile (12), de façon à ce que le mécanisme de poussée (14) soit mobile de façon synchrone avec le guide de câble (12) et que la distance entre le mécanisme de poussée (14) et le guide de câble (12) soit constante, quelle que soit la position du guide de câble (12).
2. La poulie avec guidage amélioré d'un câble et treuil avec ladite poulie selon la revendication 1, où le mécanisme de poussée (14) est conçu de n'importe quelle façon appropriée, de préférence il est conçu comme un boîtier (141) ayant un logement où au moins un, de préférence deux ou plus, disques de direction et de poussée (142) sont présents.
3. La poulie avec guidage amélioré d'un câble et treuil avec ladite poulie selon la revendication 2, où les disques de direction et de poussée (142) sont à rotation libre ou entraînés.
4. La poulie avec guidage amélioré d'un câble et treuil avec ladite poulie selon la revendication 3, où les disques de direction et de poussée (142) sont entraînés, où tous les disques ou au moins l'un d'entre eux sont entraînés.
5. La poulie avec guidage amélioré d'un câble et treuil avec ladite poulie selon la revendication 4, où chaque disque (142) est installé par le biais d'un pion

de centrage (143), une douille ou tout autre élément approprié, et un roulement à billes ou tout autre roulement adapté (144) ou un élément tel qu'un palier lisse.

5

6. La poulie avec guidage amélioré d'un câble et treuil avec ladite poulie selon l'une quelconque des revendications 2 à 5, où chaque disque (142) est doté d'une rainure semi-circulaire concave (142a) conçue de façon à recevoir le câble (2) qui passe dans le réa (13) de la poulie. 10
7. La poulie avec guidage amélioré d'un câble et treuil avec ladite poulie selon l'une quelconque des revendications 2 à 6, où le boîtier (141) des disques de direction et de poussée (142) est de préférence doté de boulons ou de toute autre manière ajustable sur le boîtier du guide de câble (12), et où au-dessus du boîtier (141) au moins un, de préférence deux ressorts de compression (145) sont montés, lesdits ressorts étant disposés de façon à pousser le boîtier complet (141) vers le réa entraîné (13). 15
20
8. La poulie avec guidage amélioré d'un câble et treuil avec ladite poulie selon l'une quelconque des revendications 2 à 7, où les pions de centrage sont protégés par des disques de rétention (147), goupilles fendues, goupilles élastiques, écrous, ou tous autres éléments similaires, où des rondelles (146) assurent une distance physique entre les disques de poussée (142) et le boîtier (141). 25
30
9. Un treuil comprenant la poulie selon l'une quelconque des revendications précédentes. 35

40

45

50

55

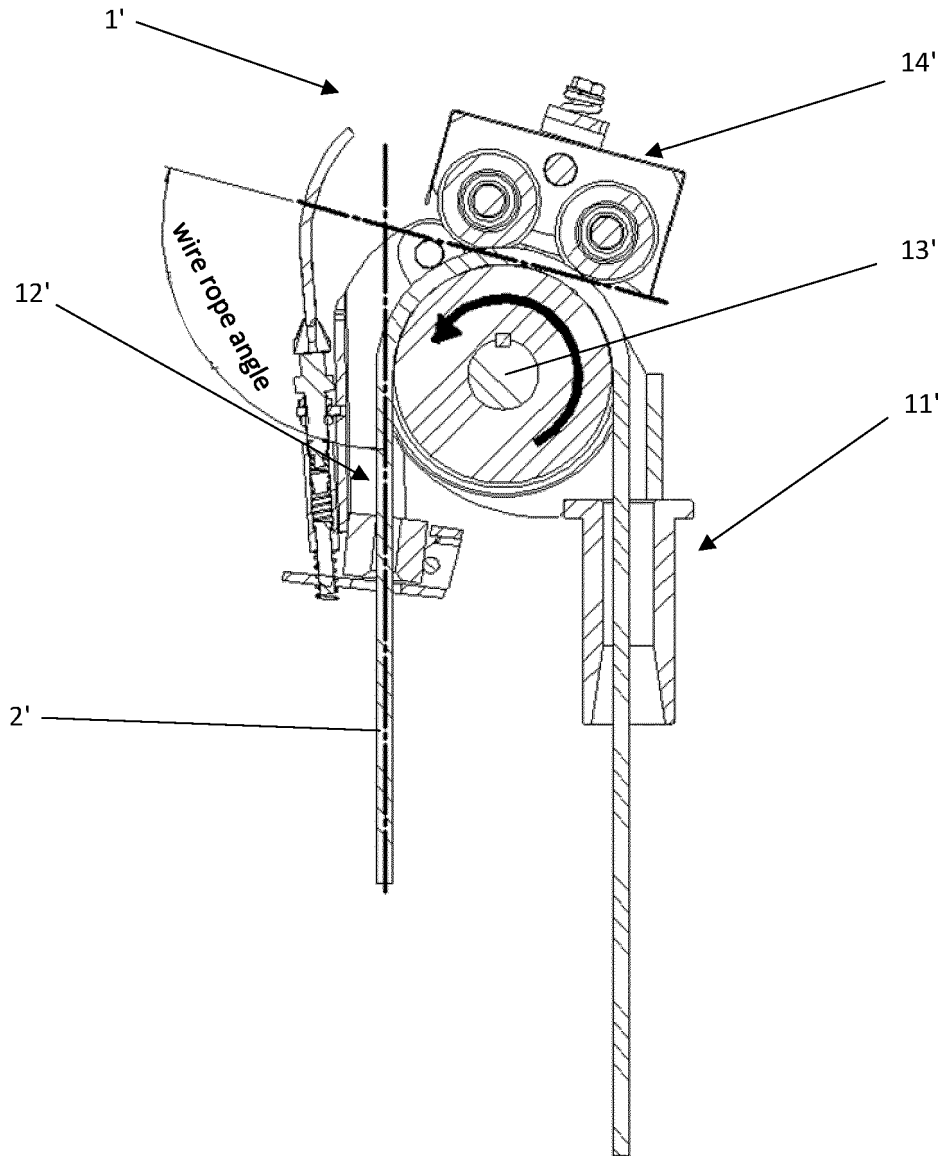

Figure 1a (prior art)

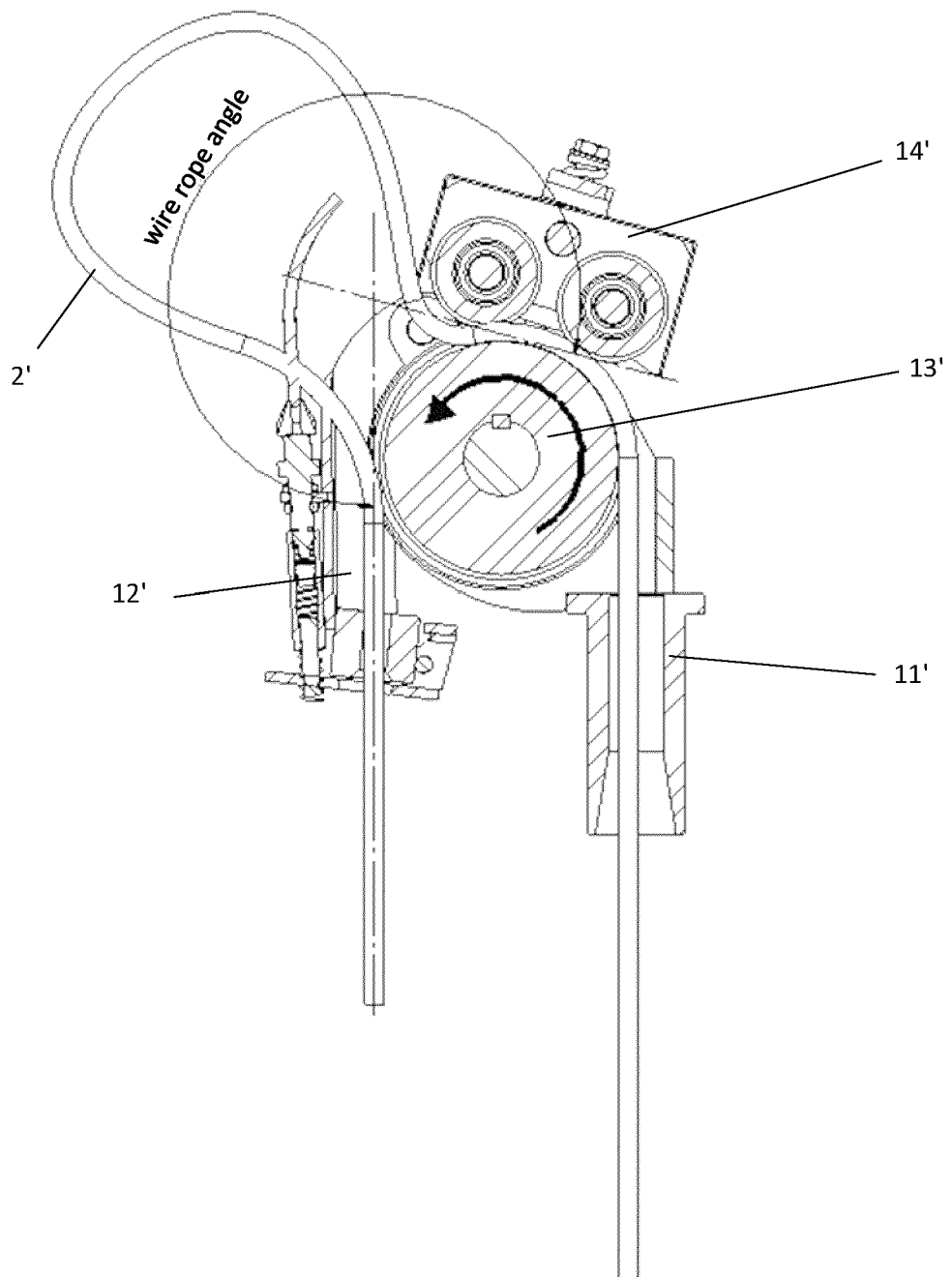

Figure 1b (prior art)

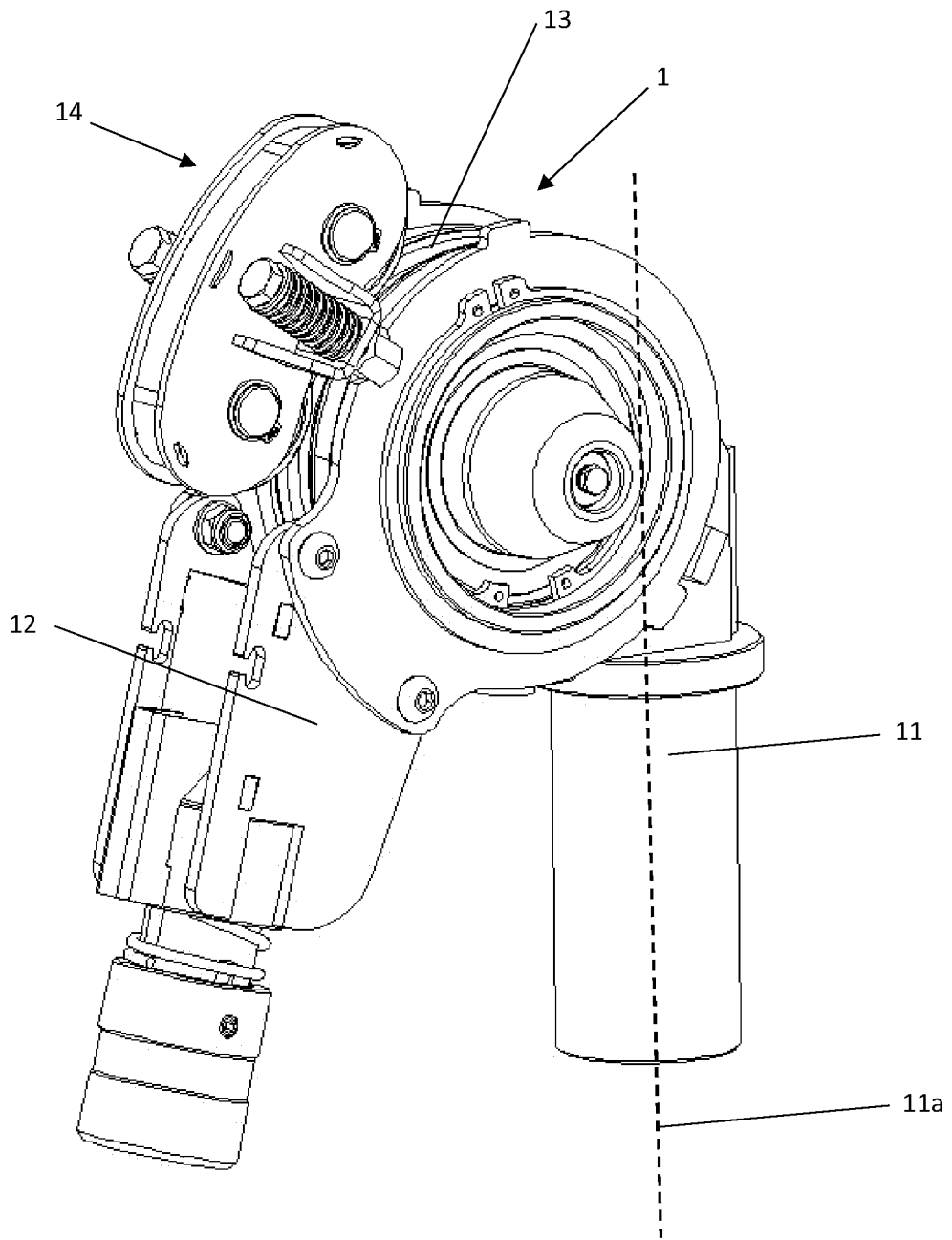

Figure 2

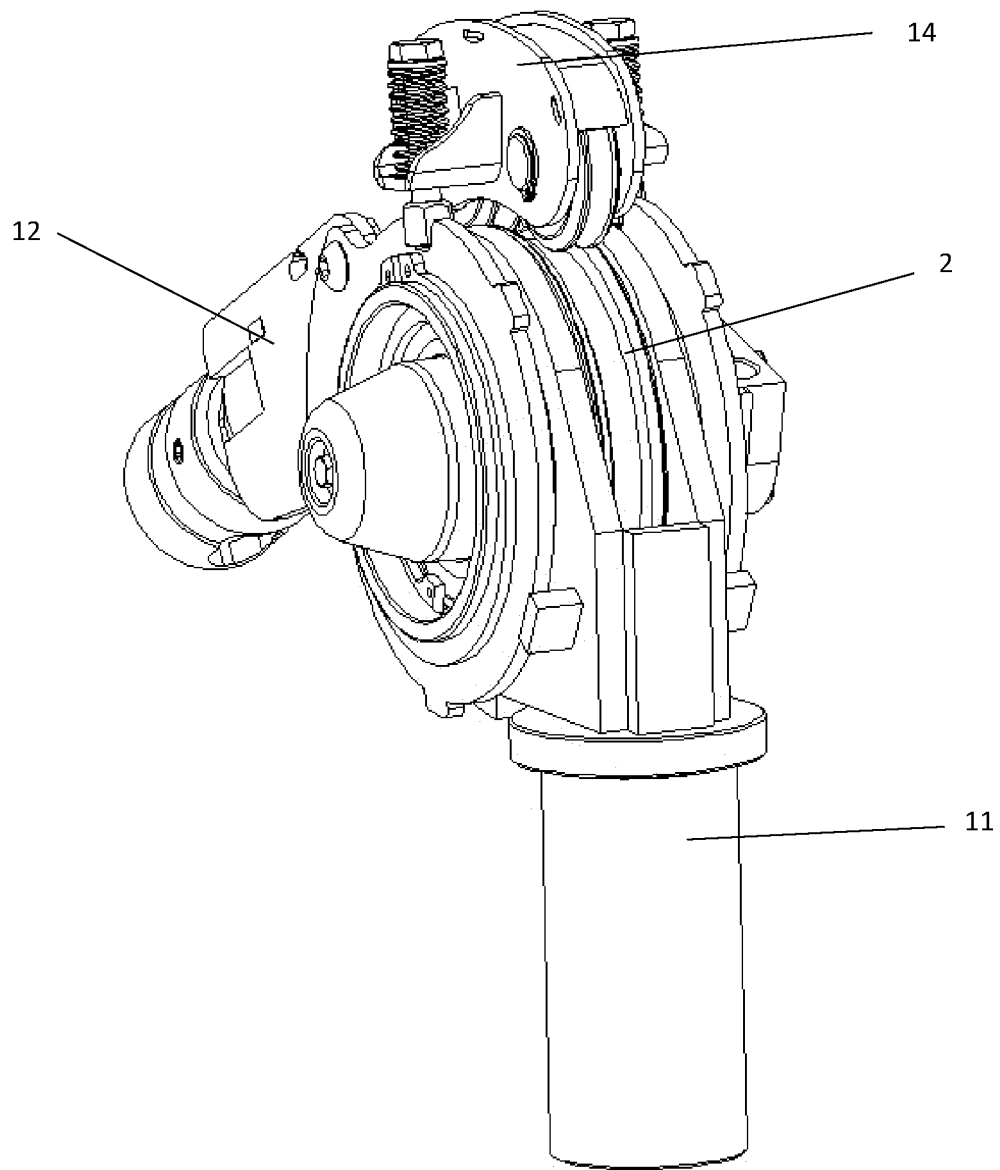

Figure 3

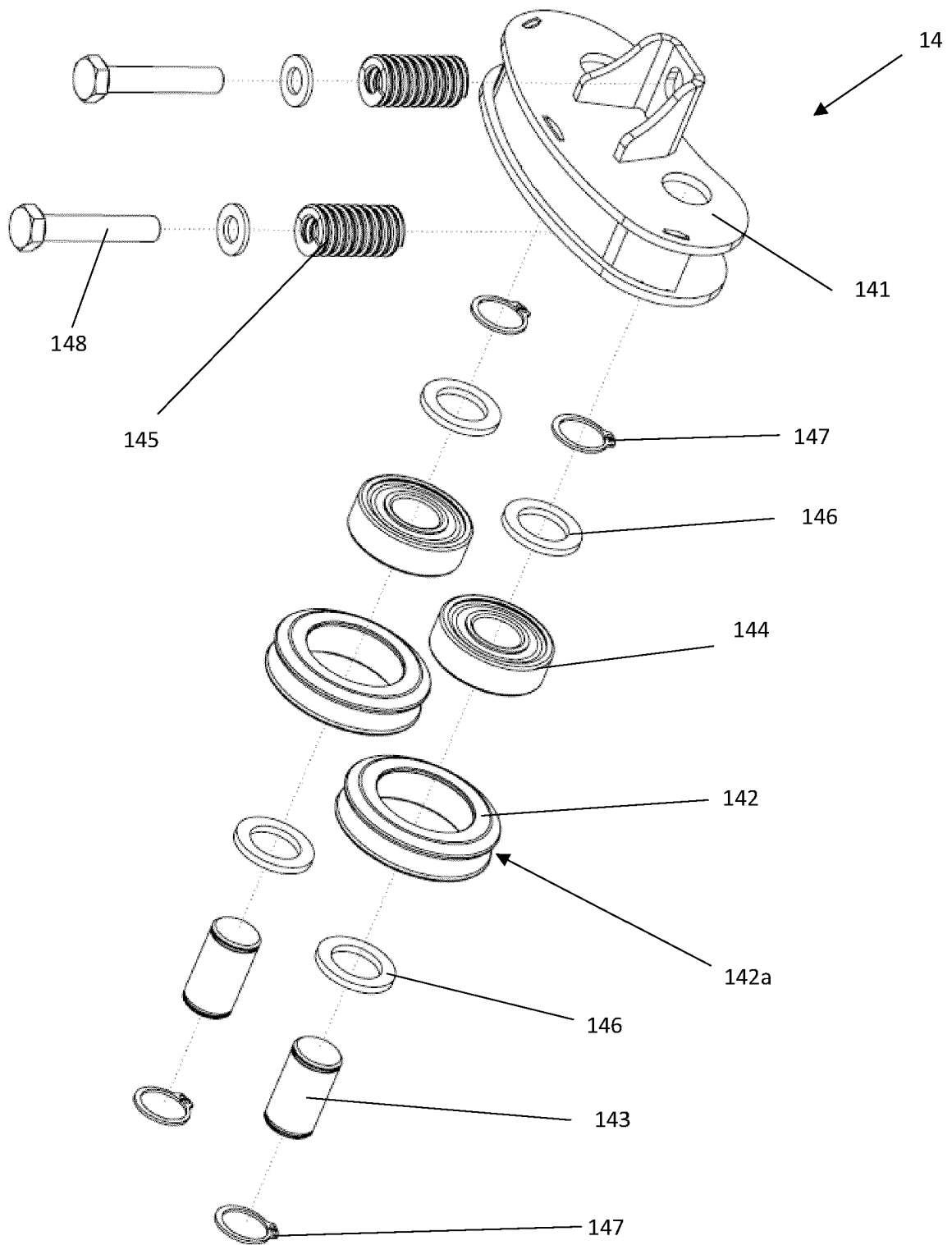

Figure 4

REFERENCES CITED IN THE DESCRIPTION

This list of references cited by the applicant is for the reader's convenience only. It does not form part of the European patent document. Even though great care has been taken in compiling the references, errors or omissions cannot be excluded and the EPO disclaims all liability in this regard.

Patent documents cited in the description

- SI 22855 [0005]
- SI 25044 [0006]
- SI 25661 [0007]
- EP 3066041 A [0008]