



(12) **EUROPEAN PATENT APPLICATION**

(43) Date of publication: **13.10.2004 Bulletin 2004/42**
 (21) Application number: **04076004.3**
 (22) Date of filing: **07.04.2004**
 (51) Int Cl.7: **A61H 35/00, A61H 33/02, A47K 3/022, A47K 3/12**

(84) Designated Contracting States:
AT BE BG CH CY CZ DE DK EE ES FI FR GB GR HU IE IT LI LU MC NL PL PT RO SE SI SK TR
 Designated Extension States:
AL HR LT LV MK
 (30) Priority: **09.04.2003 CA 424523**
 (71) Applicant: **C.G. Air Systems Inc. Sainte-Marguerite, Beauce, Quebec G0S 2X0 (CA)**

(72) Inventor: **Ciechanowski, Dominique Sainte-Marguerite, Beauce Québec (CA)**
 (74) Representative: **Elzaburu, Alberto de et al Elzaburu S.A. Miguel Angel, 21 28010 Madrid (ES)**

(54) **Foot massage system for tub and method**

(57) A foot massage system (10) for a tub, comprising a fluid injection system (12) for creating a flow of fluid. Outlets (14) are interconnected to the fluid injection system so as to receive the flow of fluid. The outlets are adapted to be secured through a tub wall so as to inject the fluid in the liquid of the tub to create a turbu-

lence in the liquid of the tub. A foot support (16) is adapted to be secured in the tub, for receiving at least one foot of a person seated in the tub. The foot support (16) is positioned relative to the outlet such that the fluid exiting the outlet creates a massaging effect on the foot received in the foot support.

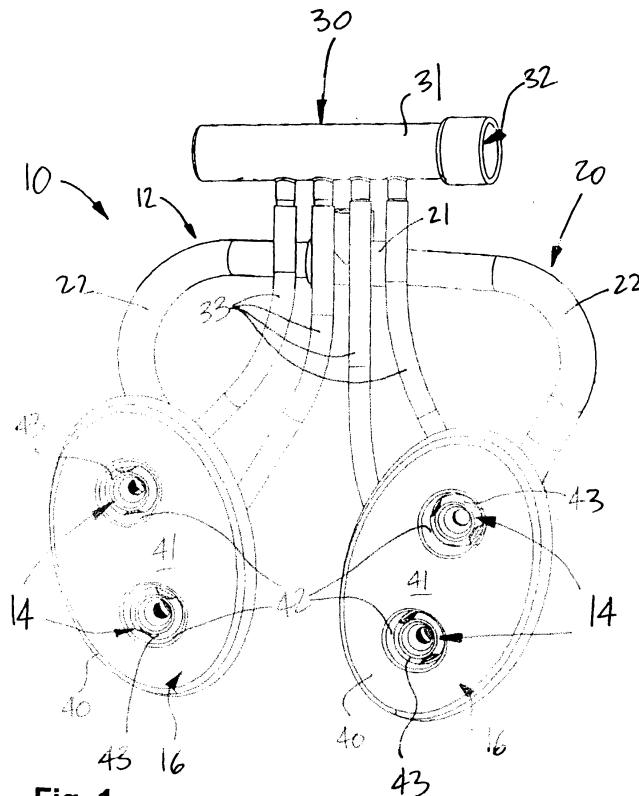

Fig. 1

Description**CROSS-REFERENCE TO RELATED APPLICATION**

[0001] This patent application claims priority on Canadian Patent Application No. 2,424,523, filed on April 9, 2003, by the present Applicant.

BACKGROUND OF THE INVENTION1. Field of the Invention

[0002] The present invention generally relates to washing/bathing tub accessories and, more particularly, to a foot massage system for a bathtub, a spa, a swimming pool, a whirlpool.

2. Background Art

[0003] The legs are very busy parts of the human anatomy. In addition to providing mobility, the legs support the remainder of the body in an upstanding position. Contractions of the multiple muscles of the legs enable humans to stand, walk, run, jump, amongst other activities. As the legs are very active parts of the human body, a variety of methods and systems are used to induce relaxation in the legs: massages, baths, oils, etc.

[0004] The feet are the interface between the body and the ground. The feet are thus associated with the balance of the human body, and accordingly are subjected to the weight of the body. Perhaps because of the wear and tear the feet go through every day, various systems have been designed specifically for the care of the feet. As an example, various types of foot massaging systems have a water receptacle in which water is heated and/or turbulence is induced so as to create a massaging effect on the feet received in the water receptacle.

[0005] U.S. Patent No. 4,184,488, issued to Bielich on January 22, 1980, describes a foot massager having a casing in which the feet of a person are received. The casing is connected to a faucet of a bathtub by a hose, such that water from the faucet is conveyed to the casing to create a massaging effect on the feet positioned in the casing.

[0006] The known foot massaging systems are designed to be used individually. Accordingly, only the feet are intended to be treated while using such foot massaging systems. Accordingly, a foot massage using the foot massage systems of the prior art is often performed before or after the user person bathes or showers. Therefore, foot massaging systems lose some appeal in that, notwithstanding the therapeutic benefits they will procure to a user person, it will take a user person some time to use them, time that is in often in addition to the showering or bathing time.

SUMMARY OF INVENTION

[0007] It is an aim of the present invention to provide a novel foot massage system.

[0008] It is a further aim of the present invention to provide a foot massage system that is used while a user person bathes in a tub.

[0009] It is a still further aim of the present invention to provide a foot massage system having components that are mounted to existing fluid injection systems of bathtubs.

[0010] It is a still further aim of the present invention to provide a novel method for providing a foot massage.

[0011] Therefore, in accordance with the present invention, there is provided a foot massage system for a tub, comprising a fluid injection system for creating a flow of fluid, at least one outlet interconnected to the fluid injection system so as to receive the flow of fluid, the outlet being adapted to be secured through a tub wall so as to inject the fluid in the liquid of the tub to create a turbulence in the liquid of the tub, and a foot support adapted to be secured in the tub, for receiving at least one foot of a person seated in the tub, the foot support being positioned relative to the outlet such that the fluid exiting the outlet creates a massaging effect on the foot received in the foot support.

[0012] Further in accordance with the present invention, there is provided a method for procuring a foot massage, comprising the steps of providing a foot support having a foot-receiving surface, and positioning the foot support under water in a tub in relation to an outlet of a fluid injection system, such that a foot on the foot-receiving surface is subjected to turbulence at the outlet of the fluid injection system.

BRIEF DESCRIPTION OF THE DRAWINGS

[0013] Having thus generally described the nature of the invention, reference will now be made to the accompanying drawings, showing by way of illustration a preferred embodiment thereof and in which:

[0014] Fig. 1 is a front perspective view of a foot massage system in accordance with a first embodiment of the present invention;

[0015] Fig. 2 is a front perspective view of the foot massage system of Fig. 1, as mounted to a tub;

[0016] Fig. 3 is a side perspective view of the foot massage system of Fig. 1, as mounted to a tub;

[0017] Fig. 4 is a side perspective view of the foot massage system of Fig. 3, as being used by a user person;

[0018] Fig. 5 is a rear perspective view of the foot massage system of Fig. 1;

[0019] Fig. 6 is a rear perspective view of the foot massage system of Fig. 5, as mounted to the tub;

[0020] Fig. 7 is a schematic view of the fluid injection system of the present invention, in relation to a tub;

[0021] Fig. 8 is an exploded view of an assembly of

the various components of the foot massage system of the present invention;

[0022] Fig. 9 is a rear perspective view of the foot massage system in accordance with a second embodiment of the present invention, in which a sequencer is used for the injection of water; and

[0023] Fig. 10 is a rear perspective view of the foot massage system in accordance with a third embodiment of the present invention, with only a gas being injected into the tub.

DESCRIPTION OF THE PREFERRED EMBODIMENTS

[0024] Referring to the drawings and, more particularly, to Figs. 1 and 2, a foot massage system in accordance with a preferred embodiment of the present invention is generally shown at 10, as mounted to a tub wall A (Fig. 2). The foot massage system 10 has a fluid injection system 12, outlets 14, and a pair of foot supports 16.

[0025] The fluid injection system 12 creates a flow of fluid, and directs the fluid toward a bathing cavity of the tub, so as to create turbulence in the water (or other liquid) in the tub. Therefore, the fluid injection system 12 is unexposed, concealed under the exposed surface of the tub, and connects to the outlets 14, positioned in openings in the tub wall A (Fig. 2), such that the fluid is injected into the water of the tub through the outlets 14.

[0026] Referring concurrently to Figs. 1 to 6, the fluid injection system 12 is shown having a water conduit network 20 and an air conduit network 30. The water conduit network 20 has a tee connector 21 that connects a flow source, as will be described hereinafter, to conduits 22.

[0027] As illustrated in the embodiment of Figs. 1 to 6, the conduits 22 are connected to the outlets 14 by various connectors. More specifically, as best seen in Fig. 5, the conduits 22 are each connected to a pair of the outlets 14 by straight pipes 23 (e.g., a nipple), one of which (for each conduit 22) is in fluid communication with a tee connector 24 on the conduit 22, the other of which (for each conduit 22) is in fluid communication with an end connector 25 on the conduit 22.

[0028] The straight pipes 23 have an upstream end connected to either one of the tee connector 24 or one of the end connector 25, and a downstream end connected to one of the outlets 14. The straight pipes 23 define a fluid passage between the upstream end and the downstream end, such that fluid may flow from the conduits 22 to the outlets 14, and into the tub. It is pointed out that the straight pipe 23 may define a fluid passage of any suitable geometry. For example, the fluid passage may have a cylindrical shape, or may be flared or tapered so as to create a variation in the flow/pressure parameters of the fluid being injected into the tub.

[0029] Each straight pipe 23 has an inlet 26 in fluid communication with the fluid passage, such that air, or

any other fluid, may be entrained with the water that passes through the straight pipes 23 to be injected through the outlets 14 in the tub. For instance, the inlet 26 radially merges into the fluid passage defined by the straight pipe 23.

[0030] The above-described configuration for the water conduit network 20 is described to illustrate one possible configuration. In this configuration, the outlets 14, the straight pipes 23, the tee connectors 24 and/or the end connectors 25 are threaded and/or tapped to facilitate their assembly and connection with tubing, or other flexible/non-flexible piping for the conduits 22. As alternatives, the tee connectors 24 and the end connectors 25 may be provided with tubing coupling ends. The conduits 22 could be connected directly to the outlets 14. The straight pipes 23 and the tee connectors 24/end connectors 25 could be made of a single piece.

[0031] As best seen in Fig. 5, the air conduit network 30 has a manifold 31 having an air intake 32, through which air will enter the manifold 31. Contemplated sources of air will be described hereinafter. Conduits 33 each extend from the manifold 31 to one of the inlets 26.

[0032] Referring to Figs. 1 and 2, the foot supports are generally shown at 16, and are typically cushions of various shape, color and texture (e.g., adapted for foot size and/or other tub configurations). The foot supports 16 each have a body 40 having a foot-receiving surface 41. A pair of throughbores 42 are defined in the body 40. The throughbores 42 project into the foot-receiving surface 41. In the embodiment illustrated in Figs. 1 and 2, connectors 43, in the shape of tubes, are lodged in the throughbores 42 so as to cooperate with the outlets 14 to secure the foot supports 16 to the outlets 14.

[0033] More specifically, the connectors 43 define a fluid passage that will be in register with the fluid passage of the outlets 14, such that fluid injected by the fluid injection system 12 passes through the fluid passage of the connectors 43. As the connectors 43 are positioned in the throughbores 42, the fluid injected by the fluid injection system 12 will project out of the foot-receiving surface 41 of the foot supports 16. Accordingly, when the feet of the bather are positioned on the foot supports 16, the feet will be subjected to the output of the fluid injection system 12, thereby creating a massaging effect thereon. The connectors 43 of the foot supports 16 are typically made of various metals, plastics, or any other material resistant to corrosion. The connectors 43 may be polished, sanded, painted, plated or chemically treated to modify the finish, the mechanical properties and the resistance to corrosion.

[0034] It is pointed out that the foot supports 16 may be removed from the remainder of the foot massage system 10. In order to do so, the connectors 43 are releasably secured to the outlets 14. For instance, the pairs of connectors 43/outlets 14 may be threaded/tapped to facilitate the interconnection therebetween. Moreover, anchoring devices with quick-coupling mechanisms can be used to facilitate the connection of the

foot supports 16 to the outlets 14.

[0035] Therefore, referring to Fig. 4, a bather may obtain a foot massage while bathing in the water W of the tub. Referring to Fig. 4, the foot B of a bather is illustrated as positioned for obtaining a foot massage from the foot massage system 10.

[0036] The foot supports 16 are advantageously removable from the remainder of the foot massage system 10. Accordingly, the foot supports 16 may be washed, or removed, if not required.

[0037] Referring to Fig. 7, the fluid injection system 12 is shown in greater detail. More specifically, the fluid injection system 12 is shown having, in addition to the various components illustrated and described hereinbefore, a flow-creating unit 50, and an input 52. The flow-creating unit is a pump, or any other means for creating a flow of liquid/fluid that will be injected into the tub. More specifically, the fluid injection system 12 has a conduit 54 that will collect the water W from the tub so as to reinject the collected water through the outlets 14, as described previously. Accordingly, the fluid injection system 12 has a conduit 56 that will interconnect the flow-creating unit 50 to the tee connector 21 (Figs. 1 to 6).

[0038] Alternatively, the fluid injection system 12 may be connected to an external source of fluid, such as the lines that will supply the faucet with water. In this instance, the flow-creating unit 50 consists of the necessary piping and valve to connect the water conduit network 20 to the external source of fluid.

[0039] The input 52 is provided such that the user person may control the foot massage system 10. For instance, the input 52 is a dial knob or a valve actuator by which the electrical supply to the flow-creating unit 50 or the pressure output to the water conduit network 20 is adjusted, so as to control the level of the massaging effect produced by the foot massage system 10.

[0040] It is pointed out that the gas source 58 of Fig. 7 is illustrated in Figs. 1 to 6 as the air conduit network 30. The gas source 58 may be equipped with a blower (not shown) that connects to the air intake 32 of the air conduit network 30, so as to create a flow of air to be injected into the tub by the foot massage system 10. Alternatively, the flow of water passing through the straight pipes 23 (Figs. 1 to 6) may entrain air into the tub, whereby no motorized pressure source in the gas source 58 would be required in such an embodiment. In the event that the gas source 58 is powered, the input 52 may be used to control the gas source 58. In the event that there is no motorized pressure source in the gas source 58, the air conduit network 30 may simply be positioned such that the air intake 32 is above the water line in the tub, such that water infiltrating the air conduit network 30 would not overflow out of the air intake 32. It is contemplated to provide the input 52 in the form of a wireless control, a touch pad or any other system.

[0041] Referring to Fig. 8, an exploded view showing the assembly of the various connectors of the foot mas-

sage system 10 is provided. More specifically, the foot massage system 10 of Fig. 8 is generally similar to that illustrated in Figs. 1 to 6 hereinabove. However, there is only one foot support 16', which is sized so as to receive a pair of feet thereon. Moreover, the foot support 16' has a support flange 44 at a bottom thereof so as to support the feet of the bather. Finally, the foot support 16' has six throughbores 42, namely three throughbores 42 per foot, as opposed to the embodiment of Figs. 1 to 6, in which the foot support 16' only has a pair of throughbores in association with a pair of outlets 14 for each foot.

[0042] It is well seen in Fig. 8 that the outlets 14 are received in openings in the tub wall A, so as to be interconnected to the straight pipes 23. The tee connectors 24 and the end connectors 25 have a male connector so as to be connected to the straight pipes 23. It is illustrated in Fig. 8 that the tee connector 24 and the end connector 25 are generally similar, but the end connector 25 has a cap so as to block an end thereof.

[0043] In the embodiment of Fig. 8, the outlets 14 are threaded so as to be screwed to the straight pipes 23. The connectors 43 cooperate with the outlets 14 so as to secure the foot support 16' to the tub wall A. As mentioned previously, the connectors 43 may be snap-fitted to the outlets 14, or screwed thereto. It is contemplated to remove the foot support 16' (or foot support 16 of Figs. 1 to 6) from the outlets 14 either by leaving the connectors 43 connected to the outlets 14, or by removing the foot supports 16' and the connectors 43.

[0044] In Fig. 9, the foot massage system 10 is shown having six conduits 22'. As opposed to the embodiment of Figs. 1 to 6, in which the water conduit network 20 diverts from an upstream tee connector 21, the conduits 22' are each associated with an own outlet 14. This embodiment is well suited to be used with a sequencer of the flow-creating unit 50 (Fig. 7) of the fluid injection system 12. More specifically, the sequencer is used for providing a sequence of fluid injection for the outlets 14.

[0045] Referring to Fig. 10, another embodiment of the foot massage system is illustrated at 10'. More specifically, the foot massage system 10' only involves the injection of air into the water of the bathtub. Accordingly, the fluid injection system 12 of the foot massage system 10' only has an air conduit network 30. The straight pipes 23 are plugged at an inlet end for this embodiment.

[0046] It is pointed out that, although the fluid injection system 12 is illustrated as having at least one conduit network, the fluid injection system 12 may also be a second shell defining a plenum with the hidden surface of the tub, with the plenum being pressurized to cause a flow of the fluid of the plenum into the water of the tub.

[0047] It is pointed out that the outlets 14, straight pipes 23 or any other component of the foot massage system 10 may be provided with check valve mechanisms, water relief valves or the like, so as to prevent water from the tub from infiltrating the foot massage system 10.

[0048] The foot massage system 10 of the present invention enables enhancement of the blood circulation in the feet in order to lessen pain in the feet, in podiatry, physiotherapy or massotherapy treatments. Moreover, the foot massage system 10 enables the combination of treatments, i.e., a user person may obtain a foot massage while bathing. Accordingly, as these two actions are performed simultaneously, the user person will save some time. Also, the legs will benefit from a bath when the user person uses the foot massage system 10 for his/her feet, whereby relaxation will be induced in the whole leg with the foot massage system 10, as opposed to the systems of the prior art.

[0049] In the event that the foot massage system 10 has liquid and gas flow-creating units, it is pointed out that either one may be operated while the other remains idle.

[0050] The foot supports 16 may be shaped such that fluid injected therethrough is strategically positioned on specific points of the feet, such as points of reflexology.

[0051] The outlets 14 may be of any type, so as to inject fluid by pulse, by rotation, multijet or concentrated jet.

[0052] It is within the ambit of the present invention to cover any obvious modifications of the embodiments described herein, provided such modifications fall within the scope of the appended claims.

Claims

1. A foot massage system for a tub, comprising:
 - a fluid injection system for creating a flow of fluid;
 - at least one outlet interconnected to the fluid injection system so as to receive the flow of fluid, the outlet being adapted to be secured through a tub wall so as to inject the fluid in the liquid of the tub to create a turbulence in the liquid of the tub; and
 - a foot support adapted to be secured in the tub, for receiving at least one foot of a person seated in the tub, the foot support being positioned relative to the outlet such that the fluid exiting the outlet creates a massaging effect on the foot received in the foot support.
2. The foot massage system according to claim 1, wherein the foot support is removable from the tub.
3. The foot massage system according to claim 2, wherein the foot support has a connector by which the foot support is releasably secured to the outlet.
4. The foot massage system according to claim 1, wherein the foot support has an opening therein, the opening being positioned in register with the outlet when the foot support is positioned relative to the outlet, such that the fluid exiting the outlet passes through the opening to create the massaging effect on the foot.
5. The foot massage system according to claim 1, comprising two of the foot support so as to provide one of the foot support per foot.
6. The foot massage system according to claim 1, wherein the at least one outlet is secured through the tub wall opposite a backrest wall of the tub.
7. The foot massage system according to claim 1, wherein the fluid injected by the fluid injection system is a mixture of a liquid and a gas.
8. The foot massage system according to claim 7, wherein the fluid injection system has a liquid circuit for collecting some liquid from the tub, pressurizing the liquid to create the flow, and directing the flow to the outlet, the gas being mixed to the fluid adjacent to the outlet.
9. The foot massage system according to claim 8, wherein the gas is air, and an air intake vent is in fluid communication with the liquid circuit such that the flow of fluid in the liquid circuit entrains air to mix with the flow of fluid.
10. The foot massage system according to claim 8, wherein the fluid injection system has a gas circuit for directing gas from a pressure source to the outlet.
11. A method for procuring a foot massage, comprising the steps of:
 - providing a foot support having a foot-receiving surface; and
 - positioning the foot support under water in a tub in relation to an outlet of a fluid injection system, such that a foot on the foot-receiving surface is subjected to turbulence at the outlet of the fluid injection system.
12. The method according to claim 11, wherein the foot support is removable secured to the outlet.

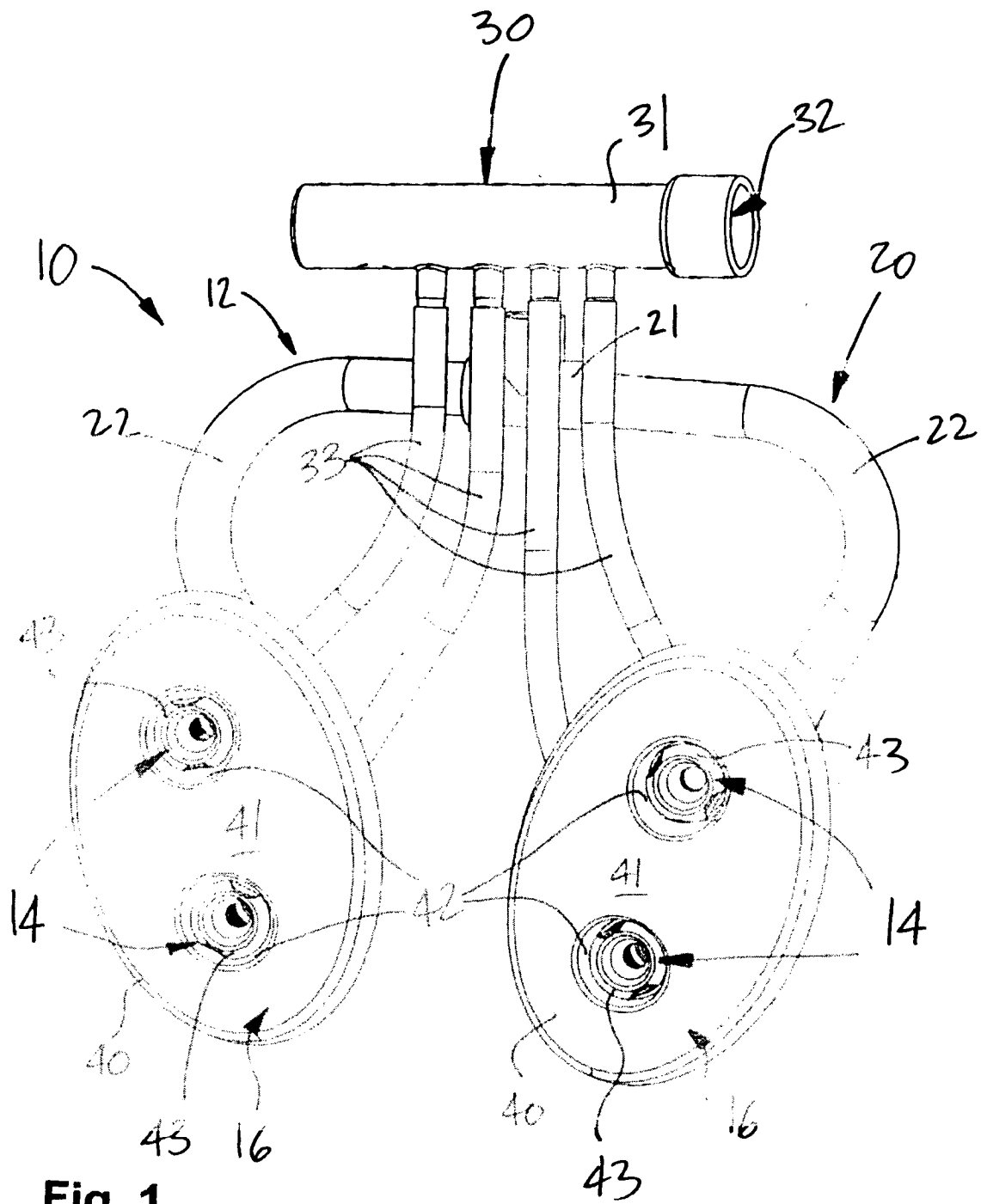

Fig. 1

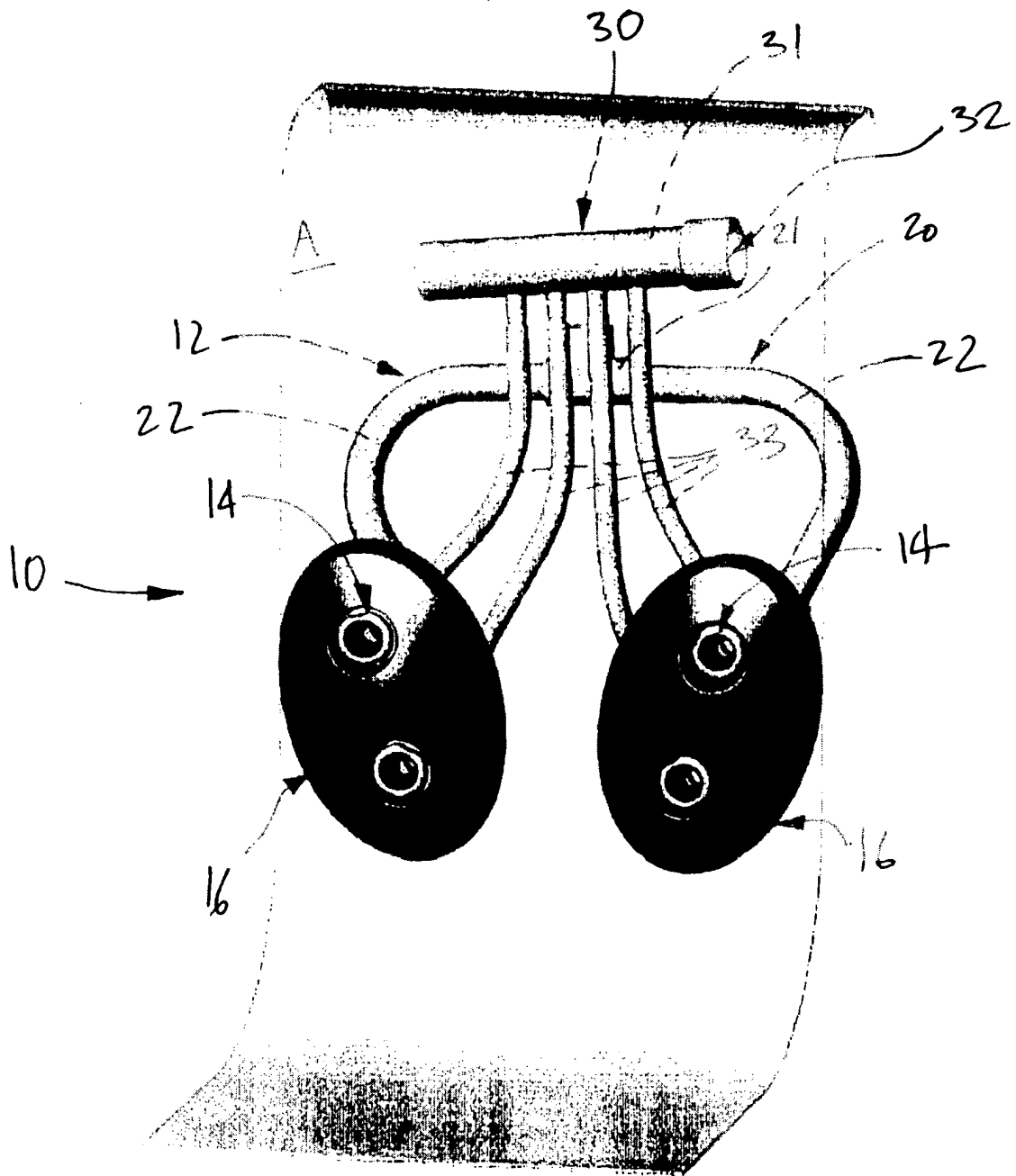

Fig. 2

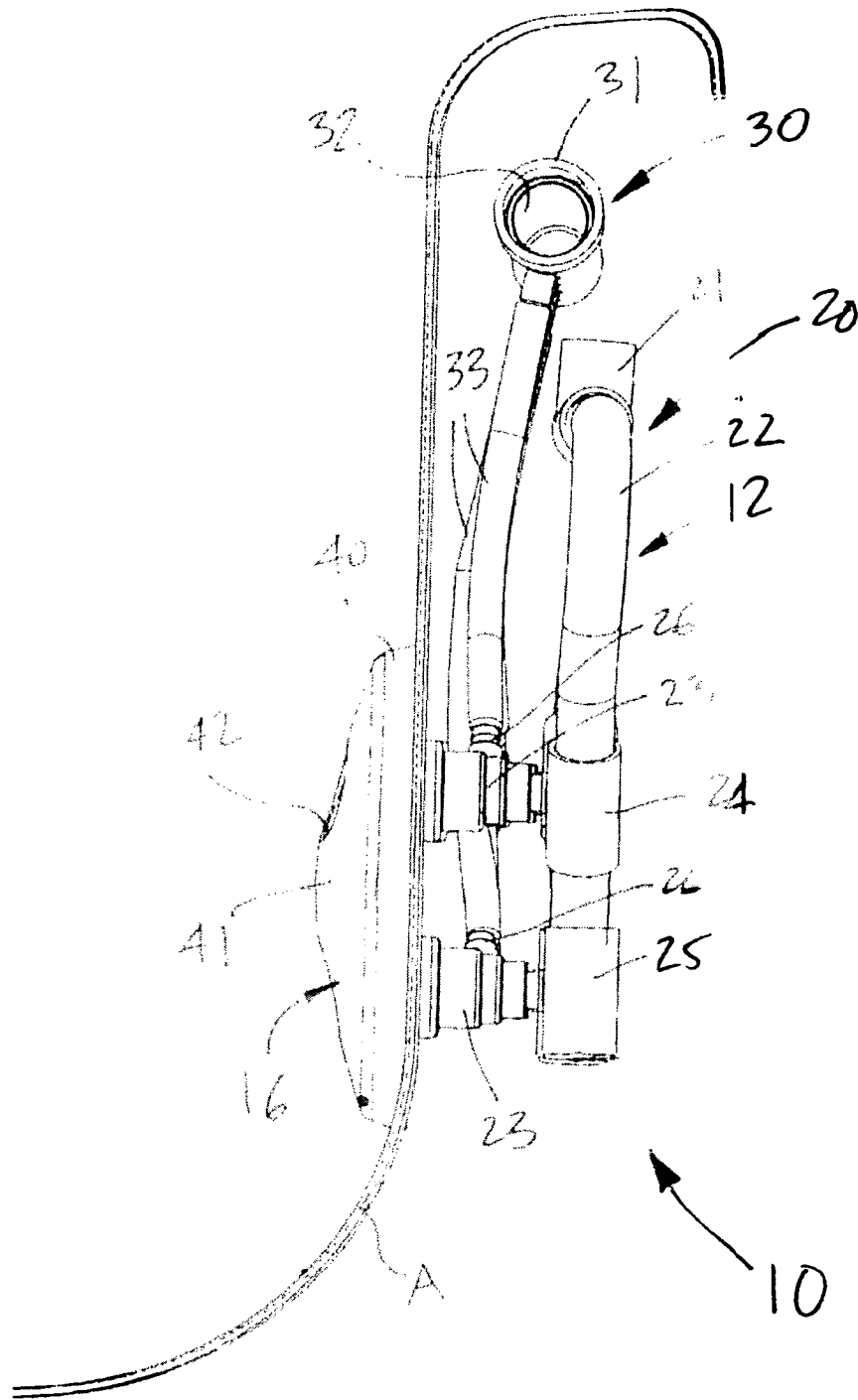

Fig. 3

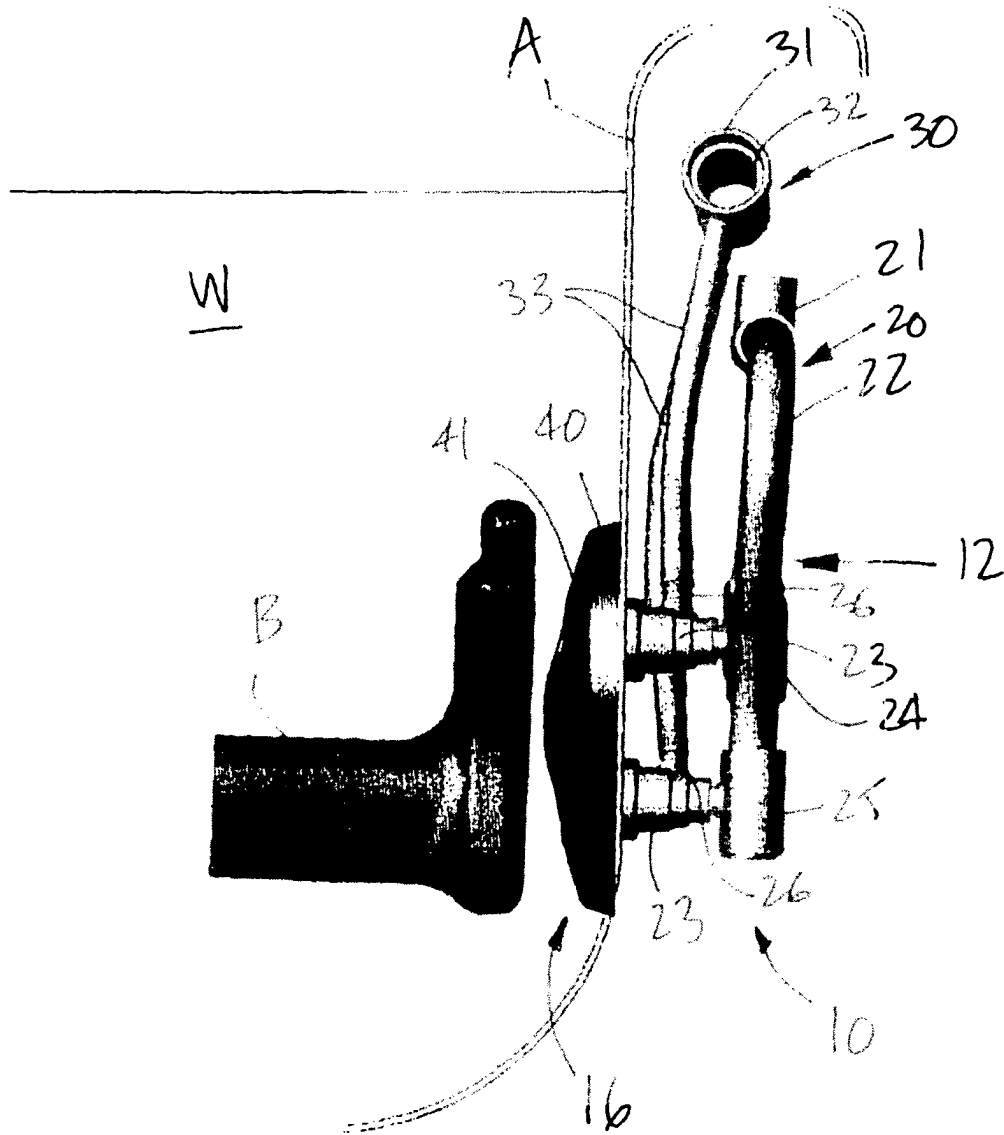

Fig. 4

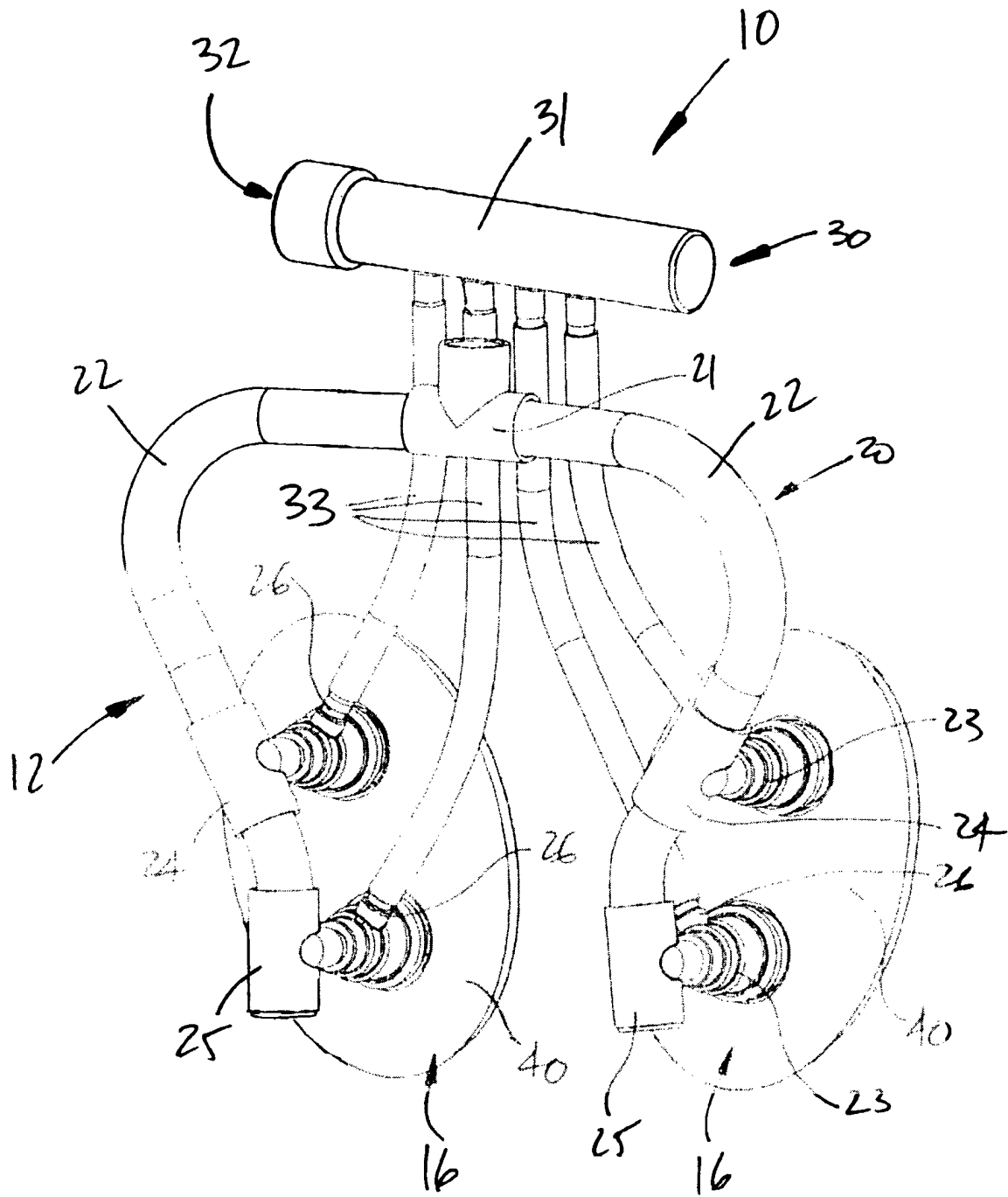

Fig. 5

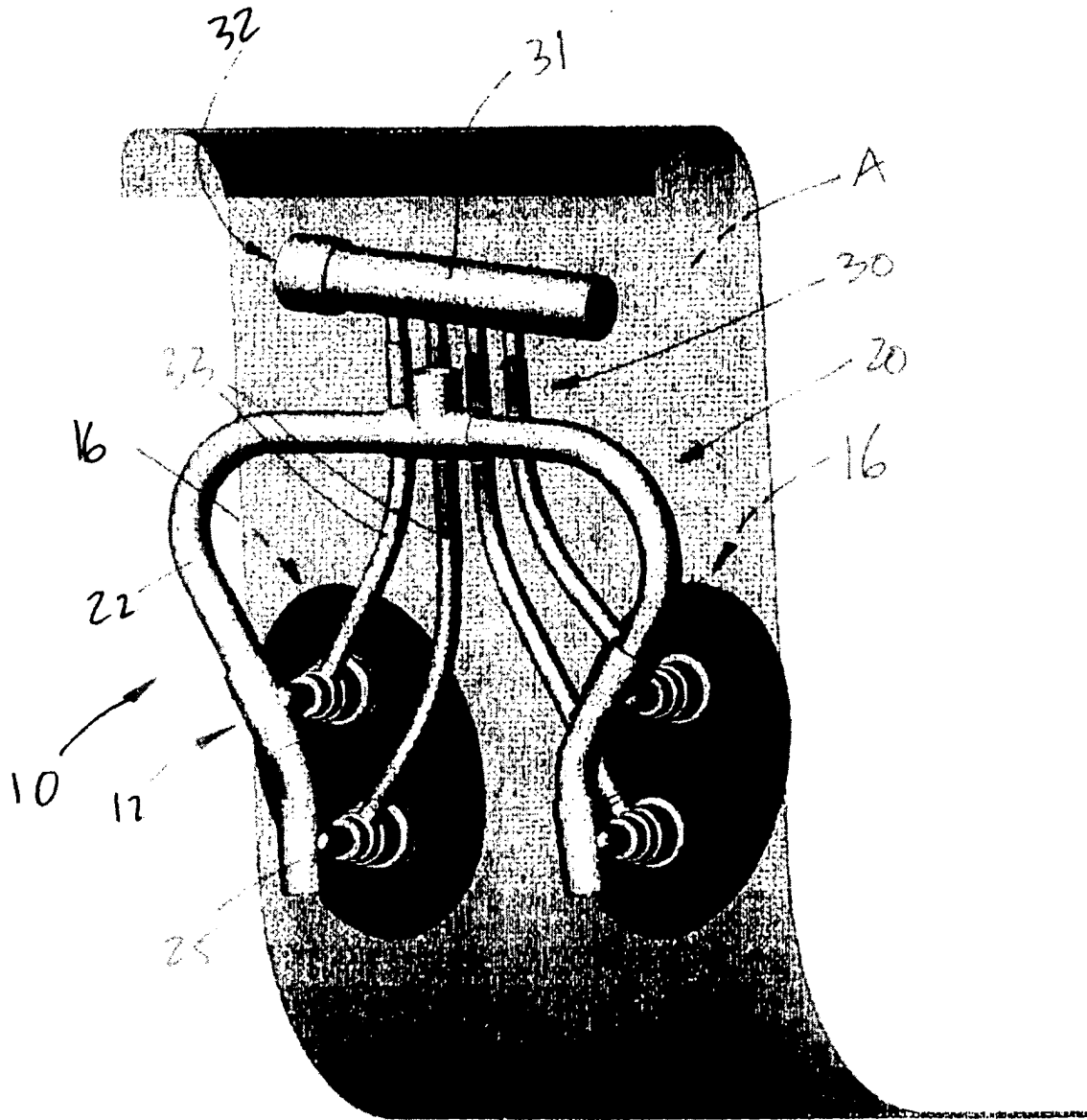

Fig. 6

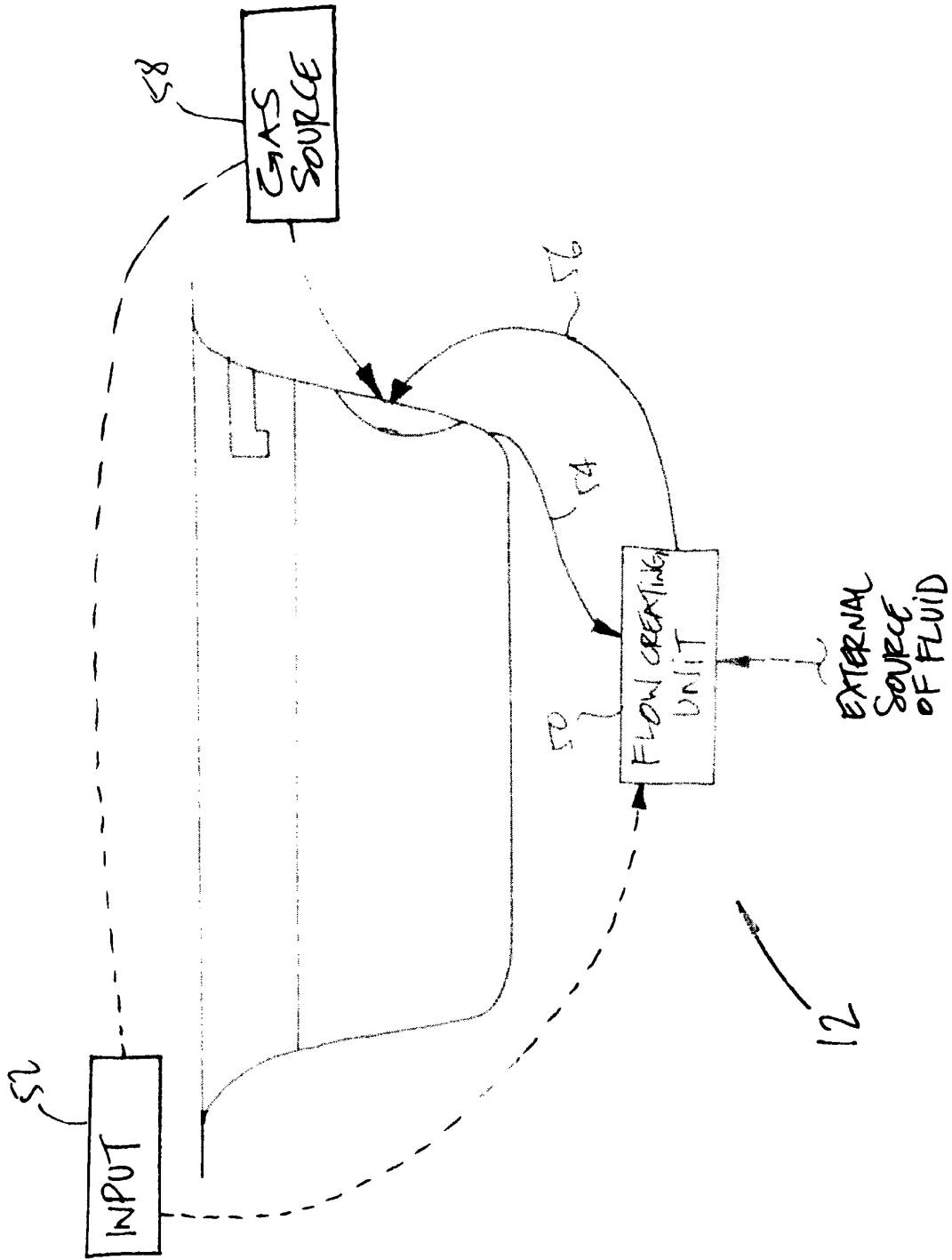

FIG. 7

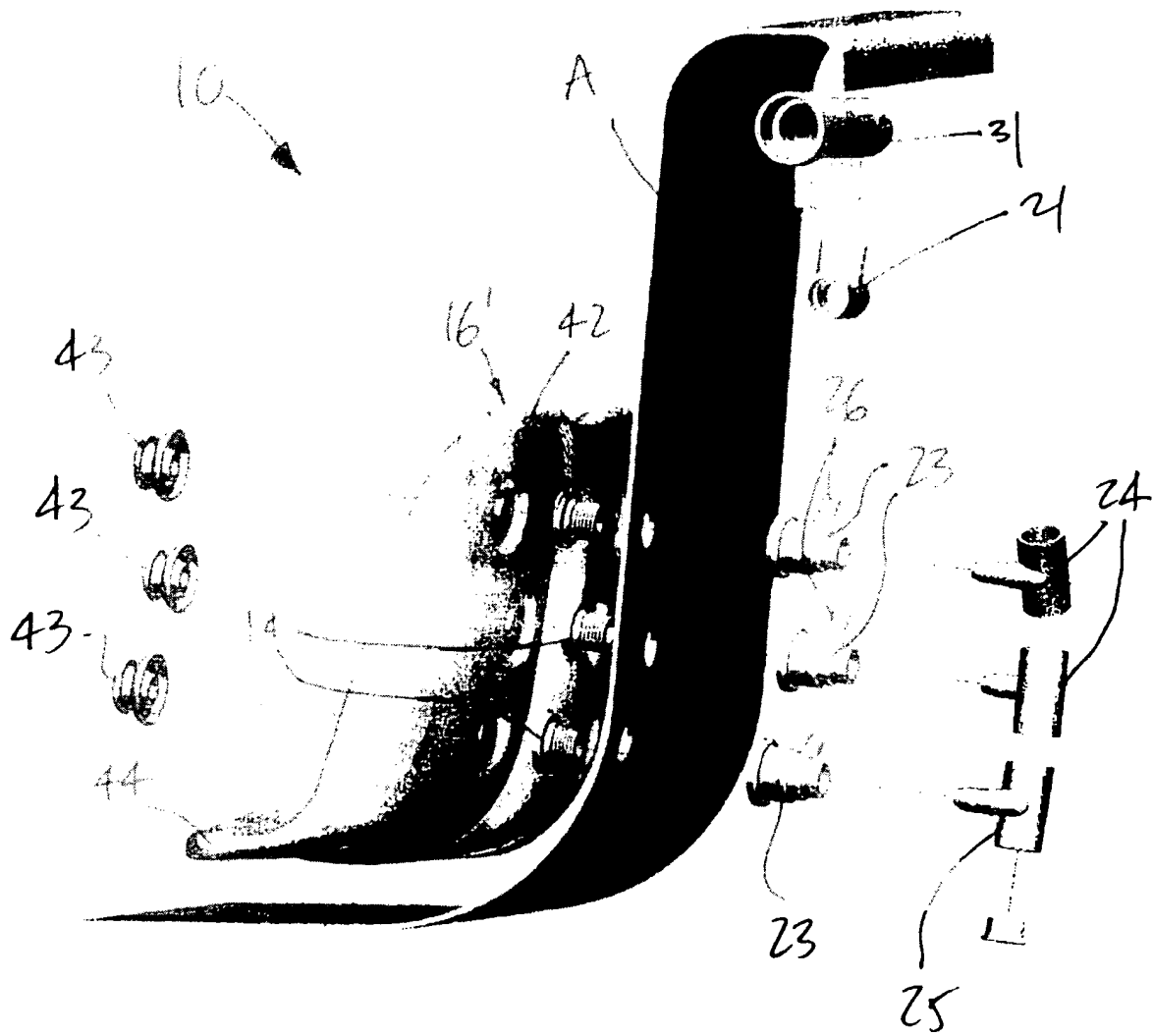

Fig. 8

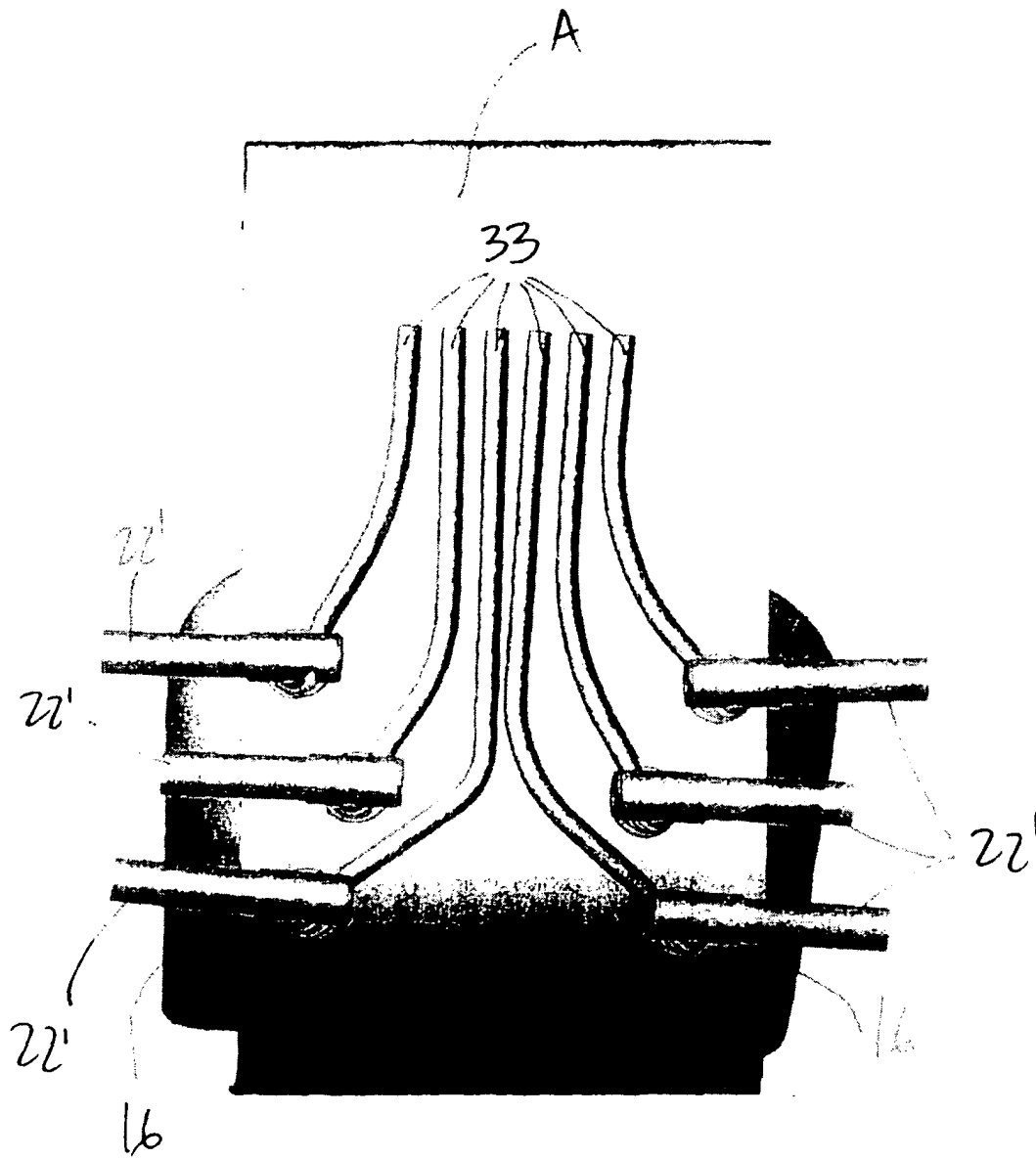

Fig. 9

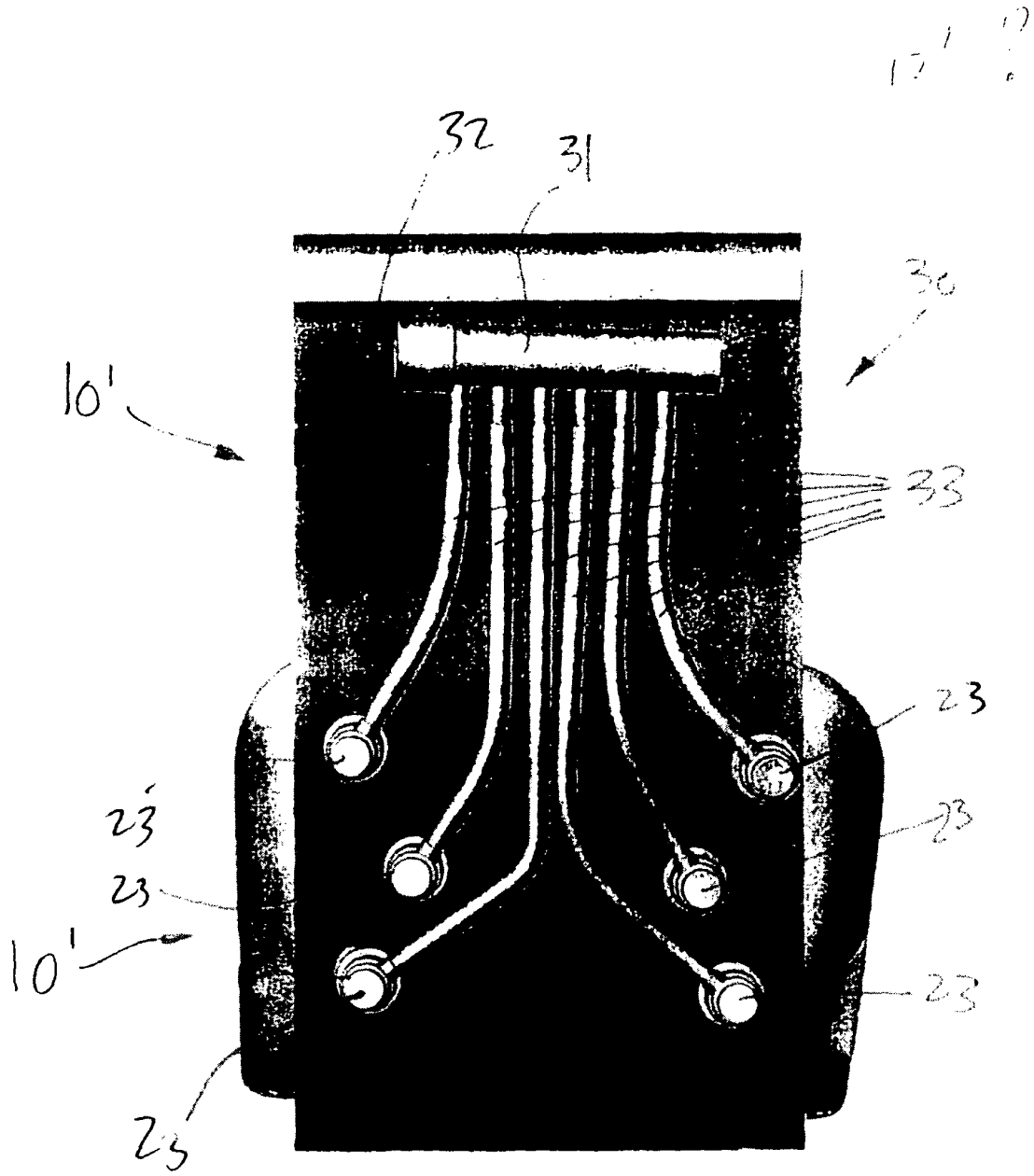

Fig. 10



European Patent Office

EUROPEAN SEARCH REPORT

Application Number
EP 04 07 6004

DOCUMENTS CONSIDERED TO BE RELEVANT			
Category	Citation of document with indication, where appropriate, of relevant passages	Relevant to claim	CLASSIFICATION OF THE APPLICATION (Int.Cl.7)
X	WO 00/74626 A (CHOI MOON HO ;M V MEDICAL VENTURE CO LTD (KR)) 14 December 2000 (2000-12-14) * page 6, line 3 - line 20 * * page 7, line 11 - line 25 * * page 8, line 12 - page 9, line 6 * * page 10, line 15 - line 23; figures 1-3 * ---	1,2,5,6, 9-12	A61H35/00 A61H33/02 A47K3/022 A47K3/12
X	US 6 327 721 B1 (DEVEREAUX SHERRY ET AL) 11 December 2001 (2001-12-11) * column 2, line 39 - line 42 * * column 3, line 6 - line 19 * * column 3, line 57 - column 4, line 13; figures 1,2,4,5 * ---	1,5-7,9, 11	
X	PATENT ABSTRACTS OF JAPAN vol. 2002, no. 09, 4 September 2002 (2002-09-04) -& JP 2002 153537 A (HITACHI TAGA TECHNOL CO LTD), 28 May 2002 (2002-05-28) Paragraphs 11-23; 35-37 * abstract; figures 1,2,7 * ---	1,2,5, 7-9,11, 12	TECHNICAL FIELDS SEARCHED (Int.Cl.7) A61H A47K
X	US 3 837 334 A (JOHNSON H) 24 September 1974 (1974-09-24) * column 1, line 60 - column 2, line 12; figure 2 * ---	1,2,11, 12	
A	EP 1 279 360 A (TITAN BAGNO S A) 29 January 2003 (2003-01-29) * paragraphs [0013]-[0019]; figure 4 * -----	1	
The present search report has been drawn up for all claims			
Place of search MUNICH		Date of completion of the search 20 July 2004	Examiner Georgiou, Z
CATEGORY OF CITED DOCUMENTS X : particularly relevant if taken alone Y : particularly relevant if combined with another document of the same category A : technological background O : non-written disclosure P : intermediate document		T : theory or principle underlying the invention E : earlier patent document, but published on, or after the filing date D : document cited in the application L : document cited for other reasons ----- & : member of the same patent family, corresponding document	

EPO FORM 1503 03.82 (P04C01)

**ANNEX TO THE EUROPEAN SEARCH REPORT
ON EUROPEAN PATENT APPLICATION NO.**

EP 04 07 6004

This annex lists the patent family members relating to the patent documents cited in the above-mentioned European search report. The members are as contained in the European Patent Office EDP file on
The European Patent Office is in no way liable for these particulars which are merely given for the purpose of information.

20-07-2004

Patent document cited in search report		Publication date	Patent family member(s)	Publication date
WO 0074626	A	14-12-2000	WO 0074626 A1	14-12-2000
			AU 4170399 A	28-12-2000

US 6327721	B1	11-12-2001	NONE	

JP 2002153537	A	28-05-2002	NONE	

US 3837334	A	24-09-1974	NONE	

EP 1279360	A	29-01-2003	EP 1279360 A1	29-01-2003
