



US00D947560S

(12) **United States Design Patent**  
**Deevers et al.**

(10) **Patent No.:** **US D947,560 S**  
(45) **Date of Patent:** **\*\* \*Apr. 5, 2022**

- (54) **CHAIR**
- (71) Applicant: **Steelcase Inc.**, Grand Rapids, MI (US)
- (72) Inventors: **Nikolaus William Charles Deevers**,  
Holland, MI (US); **Santiago Carral O’Gorman**,  
Grand Rapids, MI (US); **Gary Karsten**,  
Wyoming, MI (US)
- (73) Assignee: **STEELCASE INC.**, Grand Rapids, MI  
(US)
- (\* ) Notice: This patent is subject to a terminal disclaimer.
- (\*\*) Term: **15 Years**
- (21) Appl. No.: **29/761,463**
- (22) Filed: **Dec. 9, 2020**

22/686; B60R 22/688; B60R 22/803;  
B60R 22/986; B60R 22/914; B60R  
22/995; F16B 2/08; F16B 45/00; Y10S  
297/01; A47D 13/10

See application file for complete search history.

(56) **References Cited**

U.S. PATENT DOCUMENTS

590,045	A	9/1897	Mauchain
2,678,685	A	5/1954	Volsk
2,726,713	A	12/1955	Turner
3,559,978	A	2/1971	Molt
3,652,809	A	3/1972	Dickopp et al.
3,653,233	A	4/1972	Titone
3,709,559	A	1/1973	Rowland
3,720,568	A	3/1973	Rowland
3,724,402	A	4/1973	Thyberg et al.
3,767,261	A	10/1973	Rowland
3,774,967	A	11/1973	Rowland
3,843,477	A	10/1974	Rowland
3,948,558	A	4/1976	Obermeier et al.
D276,575	S	12/1984	Helmholdt
D276,576	S	12/1984	Helmholdt
4,502,728	A	3/1985	Sheldon et al.
D279,244	S	6/1985	Bergquist
4,574,100	A	3/1986	Mercer
4,634,178	A	1/1987	Carney
4,668,557	A	5/1987	Lakes
4,680,215	A	7/1987	Mercer
4,718,724	A	1/1988	Quinton et al.
D295,925	S	5/1988	Uredat-Neuhoff
4,889,384	A	12/1989	Sulzer
5,154,485	A	10/1992	Fleishman
5,269,631	A	12/1993	Mercer et al.
D345,867	S	4/1994	Narita
D351,291	S	10/1994	Volkle
5,447,357	A	9/1995	Dauphin
5,711,575	A	1/1998	Hand et al.
5,747,140	A	5/1998	Heerklotz
5,791,933	A	8/1998	Saka et al.
5,863,095	A	1/1999	Rivard et al.
5,871,258	A	2/1999	Batthey et al.
D408,161	S	4/1999	Caruso
5,934,758	A	8/1999	Ritch et al.
5,951,109	A	9/1999	Roslund, Jr. et al.
5,975,634	A	11/1999	Knoblock et al.
6,035,901	A	3/2000	Stumpf et al.
6,062,649	A	5/2000	Nagel et al.
6,079,785	A	6/2000	Peterson et al.
D437,501	S	2/2001	Rehmert et al.

**Related U.S. Application Data**

- (63) Continuation of application No. 29/693,247, filed on  
May 31, 2019, now Pat. No. Des. 907,935.
- (51) **LOC (13) Cl.** ..... **06-01**
- (52) **U.S. Cl.**  
USPC ..... **D6/366**
- (58) **Field of Classification Search**  
USPC ..... D6/356, 364, 365, 366, 367, 379, 716,  
D6/716.4, 716.7, 360, 380; D21/521, 695  
CPC ..... A47C 1/03294; A47C 1/034; A47C 1/032;  
A47C 1/031; A47C 1/023; A47C 3/029;  
A47C 3/027; A47C 3/04; A47C 3/02;  
A47C 3/12; A47C 4/03; A47C 4/04;  
A47C 5/12; A47C 7/029; A47C 7/02;  
A47C 7/18; A47C 7/28; A47C 7/32;  
A47C 7/38; A47C 7/40; A47C 7/44;  
A47C 7/46; A47C 7/54; A47C 7/425;  
A47C 7/445; A47C 31/023; A47C 31/04;  
B60R 2/0284; B60R 2/062; B60R 22/001;  
B60R 22/24; B60R 22/28; B60R 22/58;  
B60R 22/64; B60R 22/68; B60R 22/80;  
B60R 22/99; B60R 22/245; B60R 22/643;  
B60R 22/646; B60R 22/665; B60R

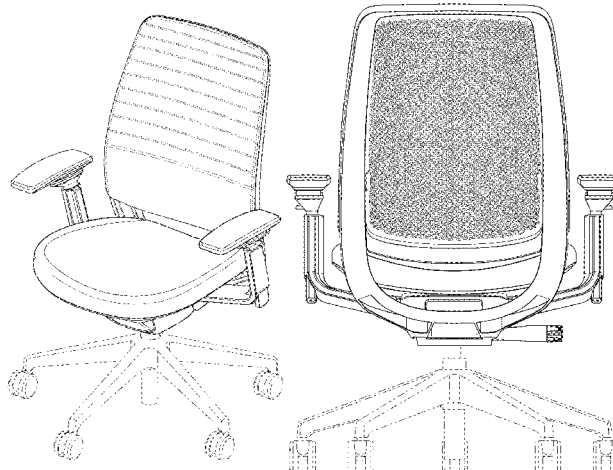

# US D947,560 S

6,189,972 B1	2/2001	Chu et al.	D600,931 S	9/2009	Pearson
D446,954 S	8/2001	Sottsass	7,594,700 B2	9/2009	Stumpf et al.
6,286,900 B1	9/2001	Roark	7,604,298 B2	10/2009	Peterson et al.
D449,172 S	10/2001	VanDeRiet et al.	D604,527 S	11/2009	Ooki et al.
6,299,248 B1	10/2001	Gennaro et al.	D607,653 S	1/2010	Wilkinson
D449,938 S	11/2001	Vanderiet et al.	7,647,714 B2	1/2010	Coffield et al.
D451,293 S	12/2001	Su	D609,482 S	2/2010	Englisch et al.
6,343,839 B1	2/2002	Simons, Jr.	7,712,834 B2	5/2010	Knoblock et al.
6,354,662 B1	3/2002	Su	7,731,295 B2	6/2010	Lin
6,361,110 B2	3/2002	Roslund, Jr. et al.	7,740,321 B2	6/2010	Brill et al.
D455,571 S	4/2002	VanDeRiet et al.	D622,985 S	9/2010	Kubryk
D456,160 S	4/2002	VanDeRiet et al.	7,794,017 B2	9/2010	Kan et al.
D456,164 S	4/2002	VanDeRiet et al.	7,794,022 B2	9/2010	Caruso et al.
D456,627 S	5/2002	Pearce et al.	7,841,665 B2	11/2010	Geister et al.
D457,739 S	5/2002	Pearce et al.	7,857,388 B2	12/2010	Bedford et al.
D460,870 S	7/2002	VanDeRiet et al.	7,866,750 B2	1/2011	Bock
6,412,593 B1	7/2002	Jones	7,887,131 B2	2/2011	Chadwick et al.
6,419,318 B1	7/2002	Albright	7,931,257 B2	4/2011	VanDeRiet et al.
D463,174 S	9/2002	Chu	D637,423 S	5/2011	Behar et al.
6,471,294 B1	10/2002	Dammermann et al.	D637,838 S	5/2011	Piretti
D471,042 S	3/2003	Schmitz et al.	D639,091 S	6/2011	Behar et al.
6,550,866 B1	4/2003	Su	D643,641 S	8/2011	Figueroa
6,568,760 B2	5/2003	Davis et al.	D643,642 S	8/2011	Figueroa
6,572,190 B2	6/2003	Koepke et al.	7,997,652 B2	8/2011	Roslund et al.
6,575,530 B1	6/2003	Fischer et al.	D644,862 S	9/2011	Gaschy
6,598,937 B2	7/2003	Caruso et al.	D647,738 S	11/2011	Chen
6,626,497 B2	9/2003	Nagamitsu et al.	D648,554 S	11/2011	Smith
6,644,752 B2	11/2003	Takata	D650,206 S	12/2011	Behar et al.
6,688,698 B1	2/2004	Chou et al.	D652,647 S	1/2012	Schaack
D487,197 S	3/2004	Edwards et al.	D652,657 S	1/2012	Behar et al.
6,709,060 B1	3/2004	Su	D653,061 S	1/2012	Behar et al.
6,726,285 B2	4/2004	Caruso et al.	D654,291 S	2/2012	Pearson et al.
D489,191 S	5/2004	Ma	D655,522 S	3/2012	Czumaj-Bront et al.
6,729,691 B2	5/2004	Koepke et al.	8,128,175 B2	3/2012	Groelsma et al.
6,733,080 B2	5/2004	Stumph et al.	D657,166 S	4/2012	Behar et al.
D494,792 S	8/2004	Schmitz et al.	8,157,329 B2	4/2012	Masoud et al.
6,805,405 B2	10/2004	Koo	D660,056 S	5/2012	Diffrient
D499,564 S	12/2004	Meda	D660,612 S	5/2012	Smith
D500,211 S	12/2004	Koch et al.	D660,622 S	5/2012	Su
6,837,546 B2	1/2005	VanDeRiet et al.	8,172,332 B2	5/2012	Masunaga et al.
6,874,852 B2	4/2005	Footitt	8,186,761 B2	5/2012	Brill et al.
6,890,030 B2	5/2005	Wilkerson et al.	8,191,970 B2	6/2012	Igarashi et al.
6,957,861 B1	10/2005	Chou et al.	8,210,611 B2	7/2012	Aldrich et al.
6,966,604 B2	11/2005	Stumpf et al.	D665,592 S	8/2012	Citterio
D513,134 S	12/2005	Asano et al.	8,246,117 B2	8/2012	Melhuish et al.
6,974,189 B2	12/2005	Machael et al.	D666,841 S	9/2012	Czumaj-Bront et al.
D513,457 S	1/2006	Asano et al.	8,297,708 B2	10/2012	Mizobata et al.
6,981,743 B2	1/2006	Edwards et al.	D671,330 S	11/2012	Izawa
7,004,543 B2	2/2006	Caruso et al.	D673,385 S	1/2013	Lu
D517,820 S *	3/2006	Citterio ..... D6/366	D673,394 S	1/2013	Hurford
D521,755 S	5/2006	Kinoshita et al.	D680,345 S	4/2013	Xingchang
7,059,682 B2	6/2006	Caruso et al.	D683,150 S	5/2013	Smith et al.
7,097,247 B2	8/2006	Batthey	8,436,508 B2	5/2013	Kornbluh et al.
7,213,886 B2	5/2007	Schmitz et al.	8,449,037 B2	5/2013	Behar et al.
7,234,773 B2	6/2007	Raftery et al.	D683,552 S	6/2013	Wu
7,247,265 B2	7/2007	Alderson et al.	D686,833 S	7/2013	Chan
7,249,802 B2	7/2007	Schmitz et al.	D688,055 S	8/2013	Baldanzi
7,252,870 B2	8/2007	Anderson et al.	8,534,648 B2	9/2013	Coffield et al.
7,275,793 B2	10/2007	Fujita et al.	D695,537 S	12/2013	Geelen
7,281,764 B2	10/2007	Thole	8,602,494 B2	12/2013	Cvek
7,293,833 B2	11/2007	Takeuchi et al.	8,652,602 B1	2/2014	Della
7,303,232 B1	12/2007	Chen	D701,068 S	3/2014	Usumoto et al.
D558,995 S	1/2008	Igarashi	D703,458 S	4/2014	Nakamura et al.
D564,264 S	3/2008	Smith et al.	D703,459 S	4/2014	Nakamura et al.
7,344,194 B2	3/2008	Maier et al.	D704,487 S	5/2014	Smith
7,347,495 B2	3/2008	Beyer et al.	D704,488 S	5/2014	Massaud
D571,568 S	6/2008	Overthun et al.	D704,945 S	5/2014	Massaud
7,406,733 B2	8/2008	Coffield et al.	D705,561 S	5/2014	Massaud
7,419,215 B2	9/2008	Wilkerson et al.	D706,547 S	6/2014	Smith
7,441,758 B2	10/2008	Coffield et al.	8,752,896 B2	6/2014	Takeuchi et al.
7,455,365 B2	11/2008	Caruso et al.	D708,466 S	7/2014	Massaud
7,472,962 B2	1/2009	Caruso et al.	D710,640 S	8/2014	Usumoto et al.
7,484,802 B2	2/2009	Beyer et al.	D711,127 S *	8/2014	Wilkinson ..... D6/366
D591,969 S	5/2009	Overthun et al.	D717,555 S	11/2014	Massaud
D597,330 S *	8/2009	Neil ..... D6/366	8,926,016 B2	1/2015	Behar et al.
D597,331 S	8/2009	Neil	D724,367 S	3/2015	Sander
7,568,768 B1	8/2009	Tsai	8,967,724 B2	3/2015	Batthey et al.
D600,052 S	9/2009	Smith et al.	D726,431 S	4/2015	Ye
D600,462 S *	9/2009	Ooki ..... D6/366	D728,292 S	5/2015	Ooki

9,095,217 B2	8/2015	Oda	DE	102016010929	4/2017
D741,099 S	10/2015	Igarashi et al.	GB	1224810	3/1971
9,155,393 B2	10/2015	Hurford et al.	JP	3974636	6/2007
D742,674 S	11/2015	Wilkinson et al.	JP	2008/000364	1/2008
9,192,237 B2	11/2015	Bachar	JP	2008/237332	10/2008
9,211,014 B2	12/2015	Schmitz et al.	JP	2009106421 A	5/2009
9,301,615 B2	4/2016	Behar et al.	JP	4462227	2/2010
9,332,851 B2	5/2016	Machael et al.	JP	2011136039 A	7/2011
D763,587 S	8/2016	Neil	JP	5386728 B2	1/2014
D763,612 S	8/2016	Goetz	JP	2014/054578	3/2014
D767,318 S	9/2016	Kubryk	JP	2016152997 A	8/2016
9,486,079 B2	11/2016	Romero	KR	10-1575774	12/2015
D773,872 S	12/2016	Kim	KR	10-1679795	11/2016
9,578,969 B1	2/2017	Su	WO	WO 1988/00523	1/1988
D782,240 S	3/2017	Wada	WO	WO 1991/01210	2/1991
9,603,451 B2	3/2017	Masunaga et al.	WO	WO 2000/53830	9/2000
D785,353 S	5/2017	Zhou	WO	WO 2003099071 A1	12/2003
9,661,930 B2	5/2017	Norman	WO	WO 2004/032686	4/2004
D789,129 S	6/2017	Fromme-Ruthmann	WO	WO 2004/088015	10/2004
D792,120 S	7/2017	Webb	WO	WO 2004/104315	12/2004
D792,717 S	7/2017	Webb	WO	WO 2007/133458	11/2007
D795,602 S	8/2017	Neil	WO	WO 2009/002479	12/2008
D799,843 S	10/2017	Chen	WO	WO 2010/049511	5/2010
D801,741 S	11/2017	Zhu	WO	WO 2012/171911	12/2012
D802,953 S	11/2017	Meda	WO	WO 2015/108143	7/2015
D816,362 S	5/2018	Su			
D825,971 S	8/2018	Scagnellato			
D846,294 S	4/2019	Peterson			
D852,525 S	7/2019	Peterson			
D869,872 S	12/2019	Deevers			
D873,576 S	1/2020	Engelhardt			
D883,690 S *	5/2020	Dassen .....	D6/366		
D889,868 S *	7/2020	Guelfo .....	D6/366		
D906,748 S *	1/2021	Wang .....	D6/716		
D907,383 S *	1/2021	Deevers .....	D6/366		
D907,935 S *	1/2021	Deevers .....	D6/366		
D915,783 S *	4/2021	Tong .....	D6/366		
D935,824 S *	11/2021	Deevers .....	D6/716.1		
D936,404 S *	11/2021	Wang .....	D6/716		
2002/0021040 A1	2/2002	Caruso et al.			
2004/0140701 A1	7/2004	Schmitz et al.			
2005/0025948 A1	2/2005	Johnson et al.			
2005/0099055 A1	5/2005	Koepke et al.			
2005/0146193 A1	7/2005	Shieh			
2006/0022506 A1	2/2006	Chan			
2006/0267258 A1	11/2006	Coffield et al.			
2006/0286359 A1	12/2006	Coffield et al.			
2007/0031667 A1	2/2007	Hook et al.			
2008/0011021 A1	1/2008	Starbuck et al.			
2008/0248710 A1	10/2008	Wittner			
2008/0258531 A1	10/2008	Lu			
2009/0020931 A1	1/2009	Coffield et al.			
2009/0021065 A1	1/2009	Brauning			
2009/0085388 A1	4/2009	Parker et al.			
2009/0239049 A1	9/2009	Hook et al.			
2010/0078975 A1	4/2010	Kang			
2011/0046715 A1	2/2011	Ugbolue et al.			
2011/0062758 A1	3/2011	Wiese			
2011/0181086 A1	7/2011	Pfeifer et al.			
2011/0282452 A1	11/2011	Koerner et al.			
2012/0007400 A1	1/2012	Behar et al.			
2012/0129416 A1	5/2012	Anand et al.			
2012/0161483 A1	6/2012	Hayashi			
2014/0084652 A1	3/2014	Norman et al.			
2014/0265493 A1	9/2014	Machael et al.			
2015/0108809 A1	4/2015	Romero			
2015/0123441 A1	5/2015	Duke			
2015/0190269 A1	7/2015	Lenoble et al.			
2015/0296989 A1	10/2015	Machael et al.			
2015/0298587 A1	10/2015	Machael et al.			
2015/0320220 A1	11/2015	Eberlein et al.			
2016/0135603 A1	5/2016	Chan et al.			

## OTHER PUBLICATIONS

“Steelcase Series 1 Work Chair Office Chair—Graphite Frame Nickel Cushions” Jun. 19, 2019, amazon.com, site visited Dec. 7, 2021 <<https://www.amazon.com/Steelcase-435A00-Office-Chair-Nickel/dp/B078HDP8NY>> (Year: 2019).\*

Alderson, A Triumph of Lateral Thought, Chemistry & Industry, dated May 17, 1999, pp. 384-391.

Amir Yeganeh-Haeri et al., “Elasticity of #-Christobalite: A Silicon Dioxide with a Negative Poisson’s Ratio,” Science, vol. 257, No. 5070, pp. 650-652, dated Jul. 31, 1992.

Baughman et al., “Negative Poisson’s Ratios as a Common Feature of Cubic Metals,” Letters to Nature, vol. 392, MacMillan Publishers Ltd., 1998; dated Mar. 26, 1998, pp. 362-265.

Boulanger et al., 1998, “Poisson’s ratio of Orthorhombic Materials,” Journal of Elasticity, vol. 50, pp. 87-89.

Choi et al., “Fracture Toughness of Renetrant Foam Materials with a Negative Poisson’s Ratio: Experiment and Analysis,” Int. J. Fracture, vol. 80, 1996, pp. 73-83.

Clark et al., 1994, “Negative Poisson’s Ratios in Angle-Ply Laminates: Theory and Experiment,” Composites, vol. 25, No. 9, pp. 863-868.

Dolla et al., “Structural and Drug Diffusion Models of Conventional and Auxetic Drug-Eluting Stents” Research Paper dated Aug. 3, 2006, pp. 1-32.

Dolla et al., Structural and Drug Diffusion Models of Conventional and Auxetic Drug-Eluting Stents, Journal of Medical Devices, vol. 1, Mar. 2007, downloaded from the Internet on Jan. 8, 2018, pp. 47-55.

Dolla, Drug Diffusion and Structural Design Criteria for Conventional and Auxetic Drug-Eluting Stents, Dissertation in Engineering and Chemistry, 2006, pp. 1-149.

Evans et al., 2004, “The Design, Matching and Manufacture of Auxetic Carbon Fiber Laminates,” Journal of Composite Materials, vol. 38, No. 2, pp. 95-106.

Hine et al., 1997, Negative Poisson’s Ratios in Angle-Ply Laminates, Journal of Materials Science Letters, vol. 16, No. 7, pp. 541-544.

Hwang, et al. 2003, downloaded from the Internet on Oct. 26, 2014, “Impact of Transport and Drug Properties on the Local Pharmacology of Drug-Eluting Stents,” International Journal of Cardiovascular Interventions, 5, pp. 7-12.

Lakes, R.S et al., 1993, Indentability of Conventional and Negative Poisson’s Ratio Foams, Journal of Composite Materials, vol. 27, pp. 1193-1202.

Lakes, R.S., 1987(a), Foam Structures with a Negative Poisson’s Ratio, Science, vol. 235, pp. 1038-1040, dated Feb. 27, 1987.

## FOREIGN PATENT DOCUMENTS

CN	2256246 Y	6/1997
CN	10149202	10/2007
CN	202932442 U	5/2013
CN	203524214 U	4/2014

Lu et al., 2004, "Biaxial Incremental Homeostatic Elastic Moduli of Coronary Artery: Two-Layer Model," *American Journal of Physiology—Heart*, vol. 287, pages H1663-1669.

Proceedings of NanoBio 2006, *Frontiers in Biomedical Devices Conference*, NanoBios2006-18035, Jun. 8-9, 2006, Irvine, California, U.S.A., pp. 1-2.

Roguin et al., BeStent—The Serpentine Balloon Expandable Stent: Review of Mechanical Properties and Clinical Experience, *Artif Organs*, vol. 22 (3), 1998, presented in part on Jun. 29-Jul. 1, 1997, in Providence, Rhode Island, U.S.A., pp. 243-249.

Smardzewski et al., "Auxetic Spring Elements for Elastically Supporting a Sitting or Lying," Article, *WULS-SGGW, Forest and Wood Technology* 73, 2011, 9 pages.

Smardzewski et al., "Design of Small Auxetic Springs for Furniture," 2 pgs.

Smardzewski, "Auxetic Springs for Seating," *Journal*, May 6, 2013, 8 pages, Poznan, Poland.

Walline, K.S., 2004, "Drug Delivery Coatings for Cardiovascular Stents: Silicone Elastomer and Thrombin Responsive Hydrogel Coatings," M.S. Thesis, University of Washington.

Warren, T.L., 1990, "Negative Poisson's Ratio in a Transversely Isotropic Foam Structure," *Journal of Applied Physics*, vol. 67, No. 12, pp. 7591-7594, dated Jun. 15, 1990.

Windecker et al., 2003, "Sirolimus Eluting Stent: A New Era in Interventional Cardiology," *Current Pharmaceutical Design*, 9, pp. 1077-1094.

\* cited by examiner

*Primary Examiner* — Kevin K Rudzinski

*Assistant Examiner* — Paul D Bohannon

(74) *Attorney, Agent, or Firm* — Crowell & Moring LLP

(57)

#### CLAIM

We claim the ornamental design for a chair, as shown and described.

#### DESCRIPTION

FIG. 1 is a top front perspective view of a chair;

FIG. 2 is a top plan view thereof;

FIG. 3 is a bottom plan view thereof;

FIG. 4 is a rear elevation view thereof;

FIG. 5 is a front elevation view thereof;

FIG. 6 is a left side elevation view thereof; and,

FIG. 7 is a right side elevation view thereof.

The uniform broken lines on the front face of the seatback depict a stitching pattern that forms part of the claimed design, while the other broken lines shown as non-uniform (dash-dot-dot) broken lines in the drawings are for the purpose of illustrating portions of the article that form no part of the claimed design.

**1 Claim, 7 Drawing Sheets**

FIG. 1

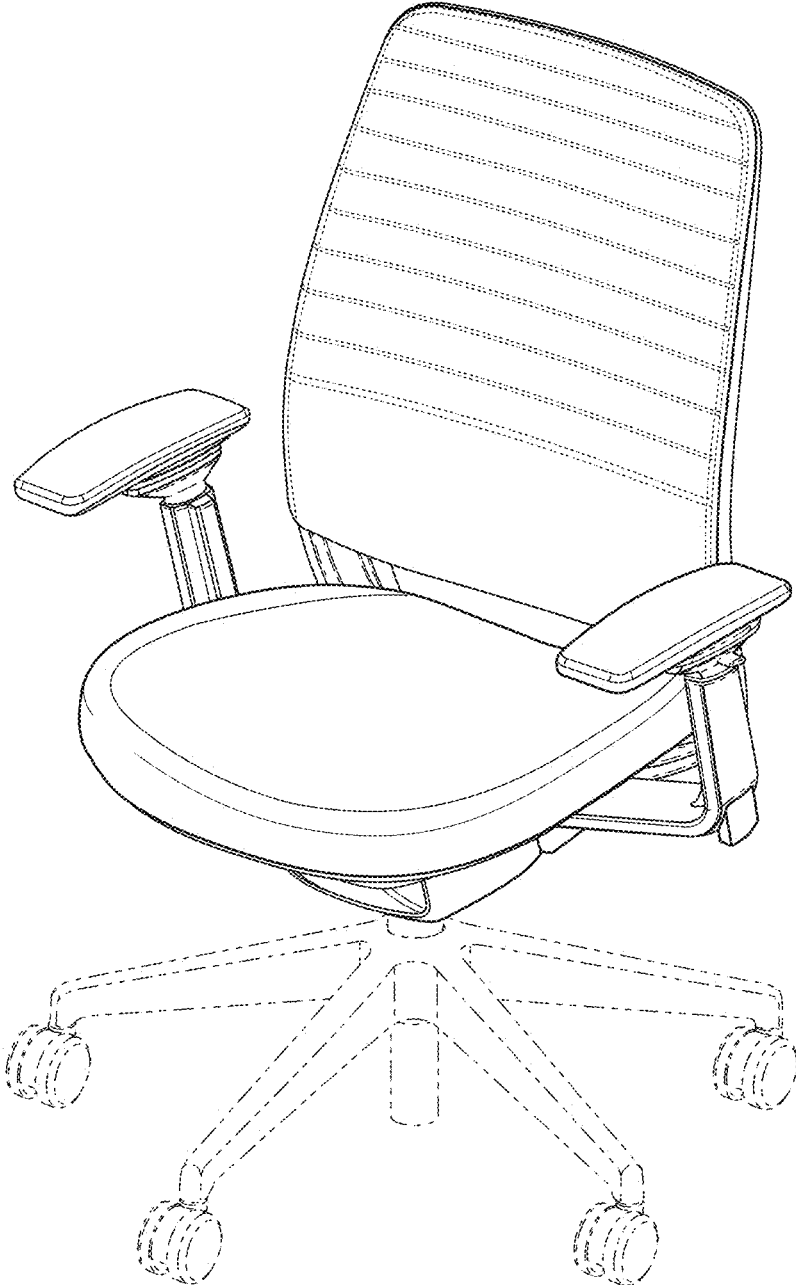

FIG. 2

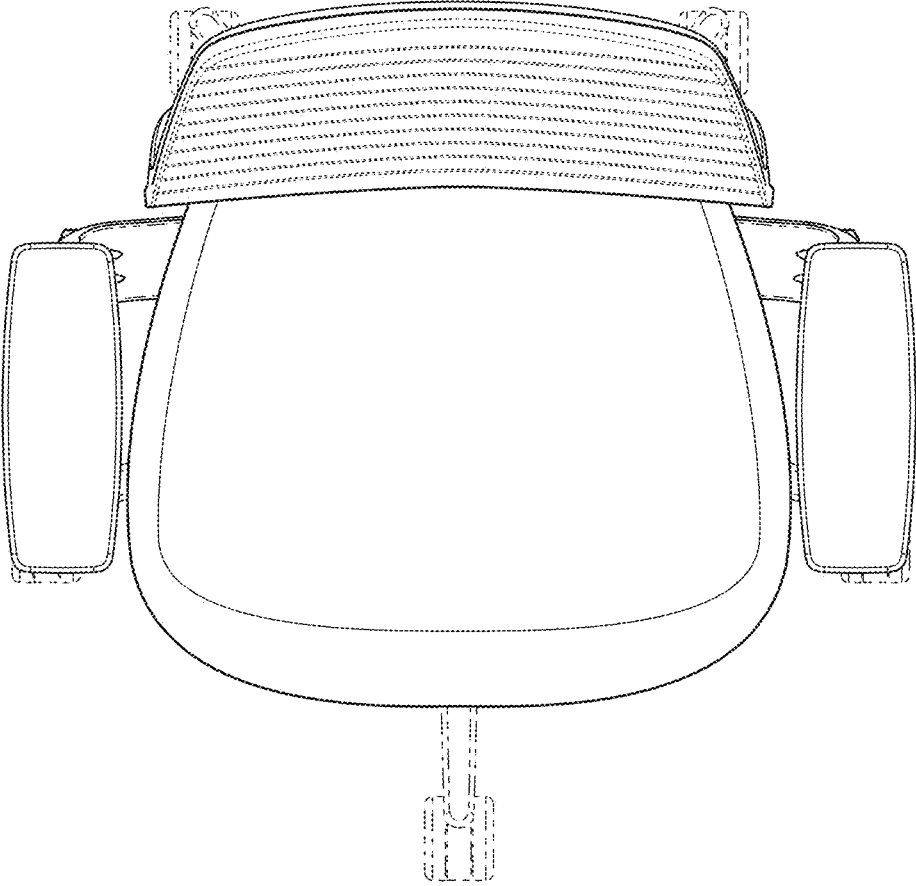

FIG. 3

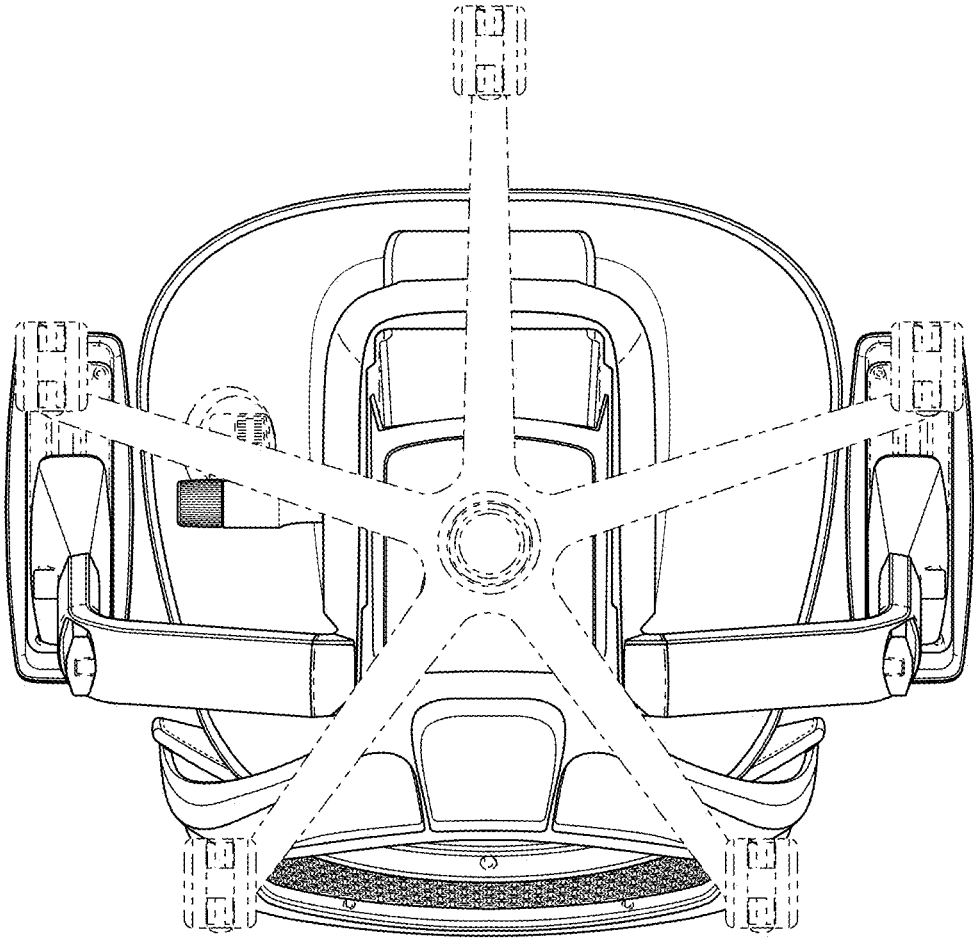

FIG. 4

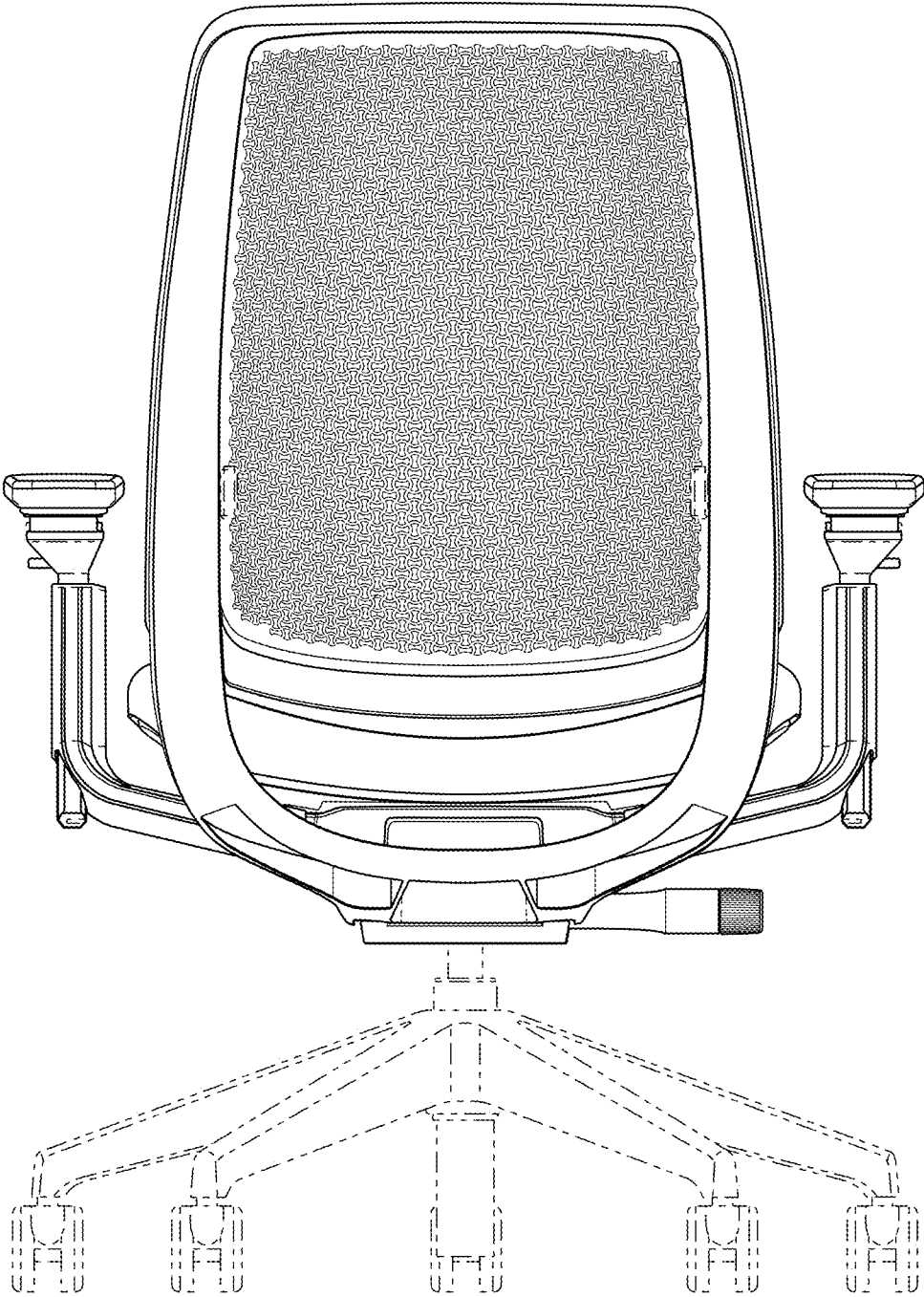



FIG. 5

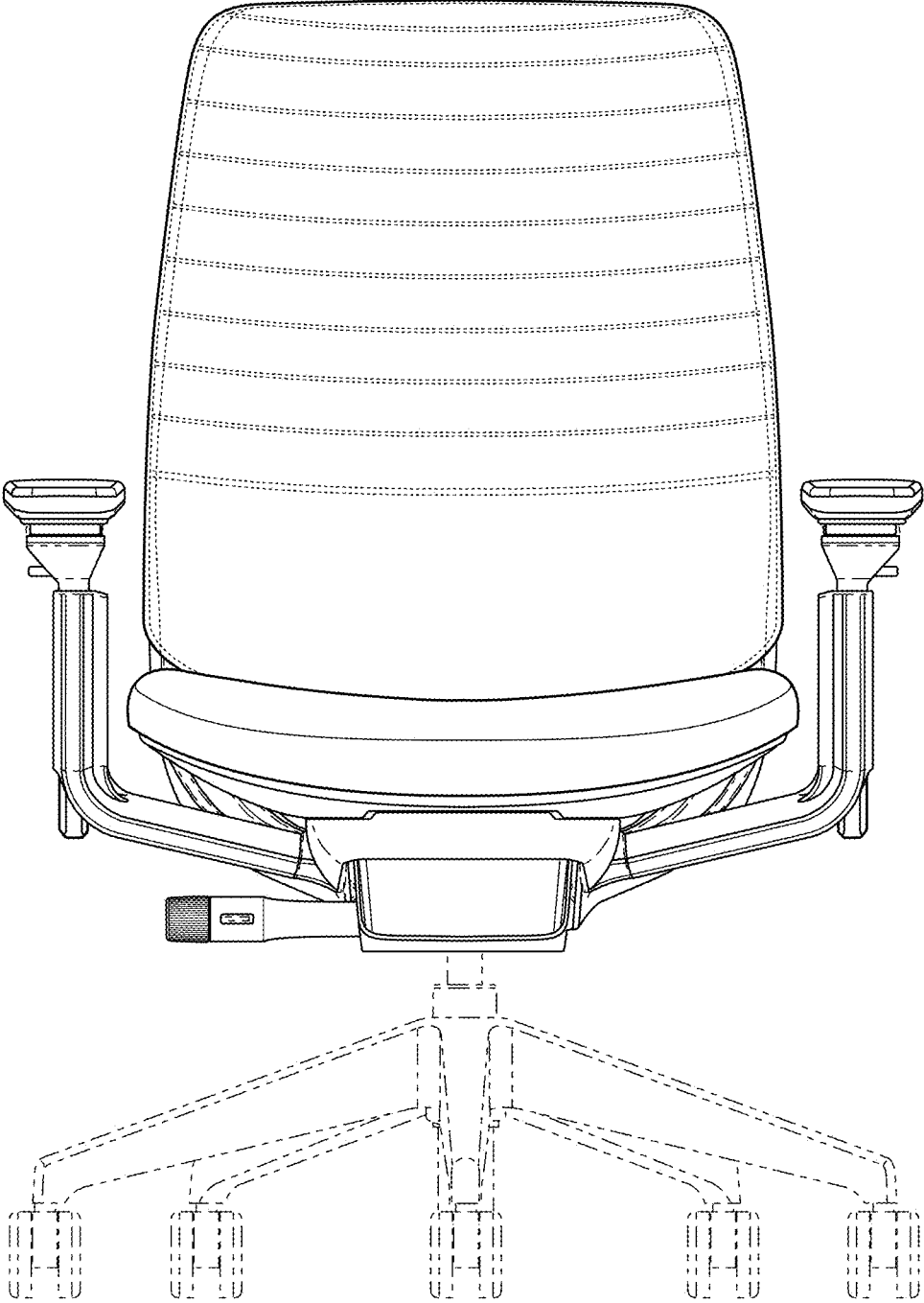

FIG. 6

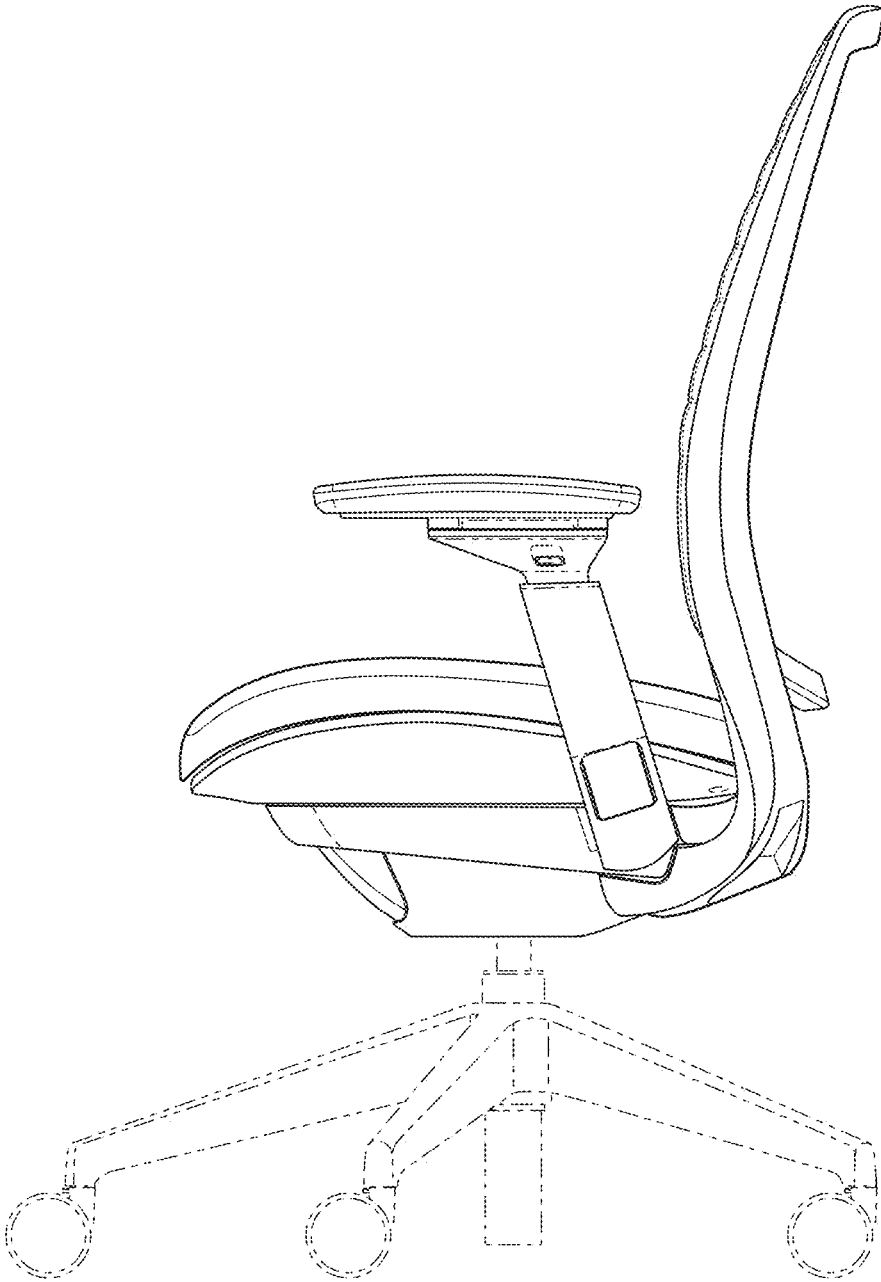

FIG. 7

