

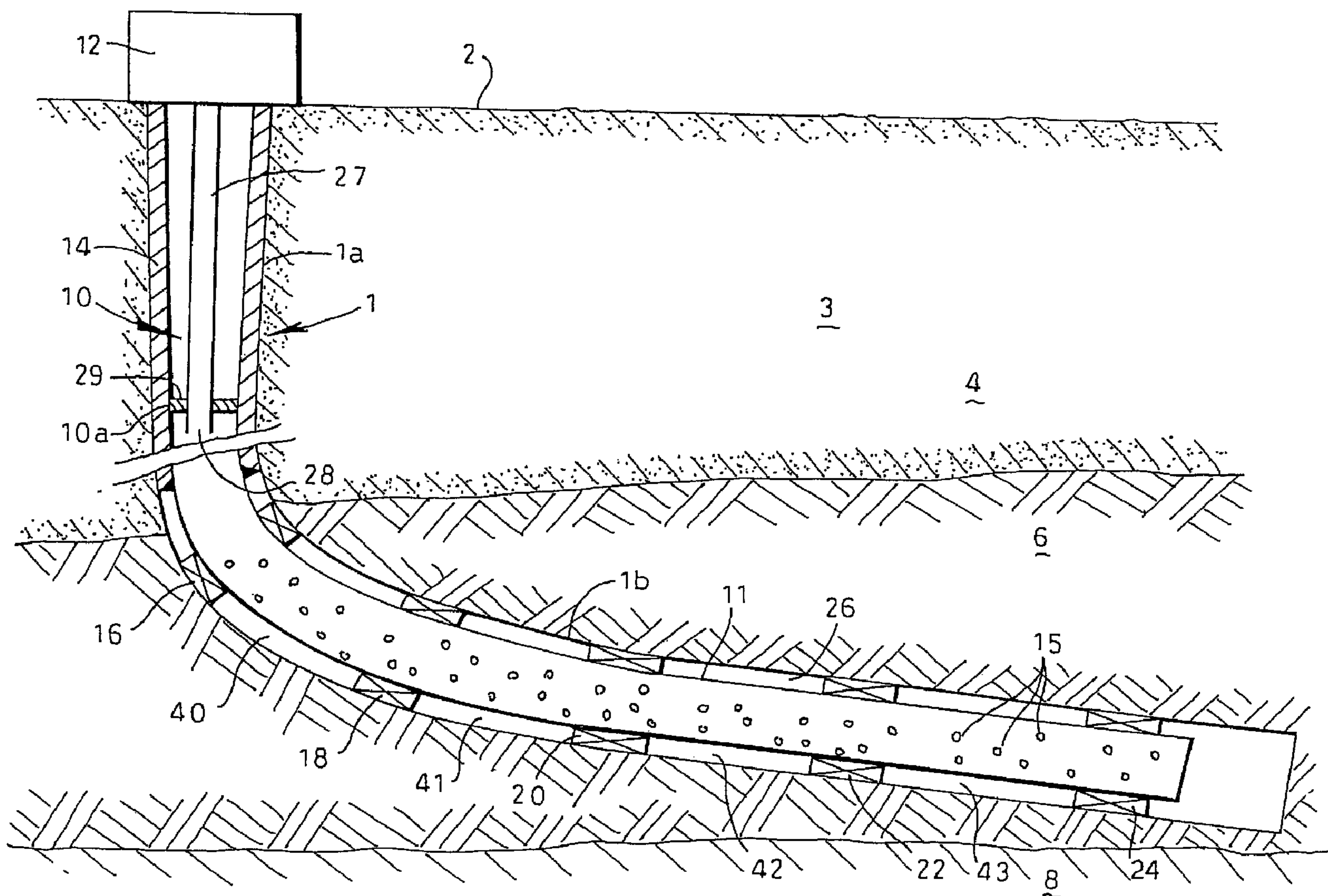

(86) Date de dépôt PCT/PCT Filing Date: 2002/07/18  
 (87) Date publication PCT/PCT Publication Date: 2003/01/30  
 (45) Date de délivrance/Issue Date: 2010/02/09  
 (85) Entrée phase nationale/National Entry: 2004/01/14  
 (86) N° demande PCT/PCT Application No.: EP 2002/008046  
 (87) N° publication PCT/PCT Publication No.: 2003/008756  
 (30) Priorité/Priority: 2001/07/18 (EP01306178.3)

(51) Cl.Int./Int.Cl. *E21B 33/12* (2006.01),  
*E21B 33/124* (2006.01), *E21B 43/10* (2006.01)  
 (72) Inventeurs/Inventors:  
BOSMA, MARTIN GERARD RENE, NL;  
CORNELISSEN, ERIK KERST, NL  
 (73) Propriétaire/Owner:  
SHELL CANADA LIMITED, CA  
 (74) Agent: SMART & BIGGAR

(54) Titre : SYSTEME DE Puits DE FORAGE A ELEMENT D'ETANCHEITE ANNULAIRE  
 (54) Title: WELLBORE SYSTEM WITH ANNULAR SEAL MEMBER



(57) Abrégé/Abstract:

A wellbore system comprising a borehole extending into an earth formation, a tubular element extending into the borehole whereby a cylindrical wall surrounds the tubular element in a manner that an annular space is formed between the tubular element and the

(57) **Abrégé(suite)/Abstract(continued):**

cylindrical wall, at least one seal member arranged in said annular space, each seal member being movable between a retracted mode in which the seal member has a first volume and an expanded mode in which the seal member has a second volume larger than the first volume, wherein the seal member in the expanded mode thereof seals the annular space, and wherein the seal member includes a material which swells upon contact with a selected fluid so as to move the seal member from the retracted mode to the expanded mode thereof.

## (12) INTERNATIONAL APPLICATION PUBLISHED UNDER THE PATENT COOPERATION TREATY (PCT)

(19) World Intellectual Property Organization  
International Bureau(43) International Publication Date  
30 January 2003 (30.01.2003)

PCT

(10) International Publication Number  
WO 03/008756 A1(51) International Patent Classification<sup>7</sup>: E21B 33/124,  
43/10, 33/12Gerard, Rene [NL/NL]; Volmerlaan 8, NL-2288 GD  
Rijswijk (NL). CORNELISSEN, Erik, Kerst [NL/NL];  
Volmerlaan 8, NI-2288 GD Rijswijk (NL).

(21) International Application Number: PCT/EP02/08046

(22) International Filing Date: 18 July 2002 (18.07.2002)

(25) Filing Language: English

(26) Publication Language: English

(30) Priority Data:  
01306178.3 18 July 2001 (18.07.2001) EP(71) Applicant (for all designated States except CA,  
US): SHELL INTERNATIONALE RESEARCH  
MAATSCHAPPIJ B.V. [NL/NL]; Carel van Bylandtlaan  
30, NL-2596 HR The Hague (NL).(81) Designated States (national): AE, AG, AL, AM, AT, AU,  
AZ, BA, BB, BG, BR, BY, BZ, CA, CH, CN, CO, CR, CU,  
CZ, DE, DK, DM, DZ, EC, EE, ES, FI, GB, GD, GE, GH,  
GM, HR, HU, ID, IL, IN, IS, JP, KE, KG, KP, KR, KZ, LC,  
LK, LR, LS, LT, LU, LV, MA, MD, MG, MK, MN, MW,  
MX, MZ, NO, NZ, OM, PH, PL, PT, RO, RU, SD, SE, SG,  
SI, SK, SL, TJ, TM, TN, TR, TT, TZ, UA, UG, US, UZ,  
VN, YU, ZA, ZM, ZW.(71) Applicant (for CA only): SHELL CANADA LIMITED  
[CA/CA]; 400, 4th Avenue S.W., Calgary, Alberta T2P 2H5  
(CA).(84) Designated States (regional): ARIPO patent (GH, GM,  
KE, LS, MW, MZ, SD, SL, SZ, TZ, UG, ZM, ZW),  
Eurasian patent (AM, AZ, BY, KG, KZ, MD, RU, TJ, TM),  
European patent (AT, BE, BG, CH, CY, CZ, DE, DK, EE,  
ES, FI, FR, GB, GR, IE, IT, LU, MC, NL, PT, SE, SK,  
TR), OAPI patent (BF, BJ, CF, CG, CI, CM, GA, GN, GQ,  
GW, ML, MR, NE, SN, TD, TG).

(72) Inventors; and

Published:

(75) Inventors/Applicants (for US only): BOSMA, Martin,

— with international search report

[Continued on next page]

(54) Title: WELLBORE SYSTEM WITH ANNULAR SEAL MEMBER

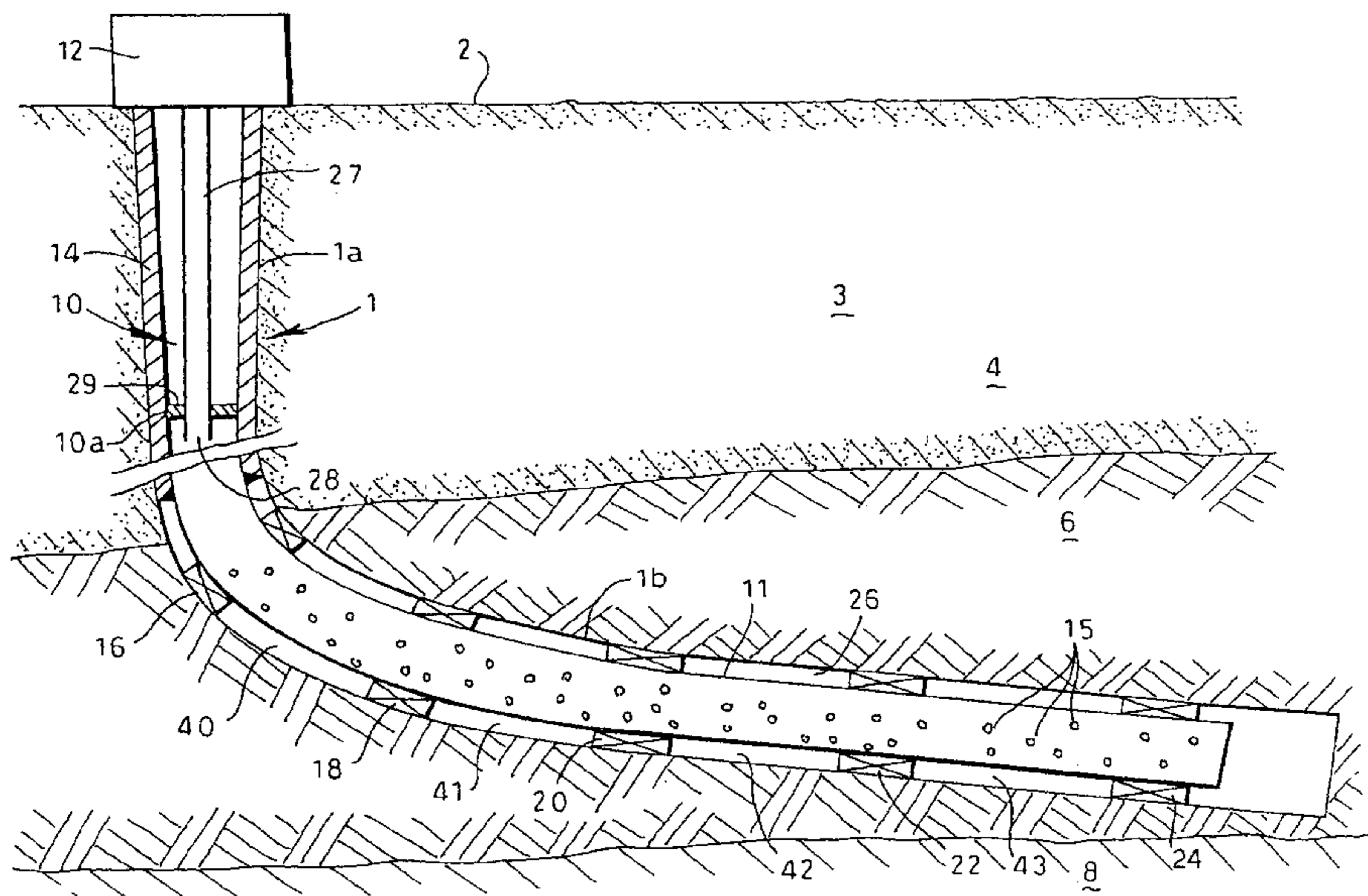

(57) Abstract: A wellbore system comprising a borehole extending into an earth formation, a tubular element extending into the borehole whereby a cylindrical wall surrounds the tubular element in a manner that an annular space is formed between the tubular element and the cylindrical wall, at least one seal member arranged in said annular space, each seal member being movable between a retracted mode in which the seal member has a first volume and an expanded mode in which the seal member has a second volume larger than the first volume, wherein the seal member in the expanded mode thereof seals the annular space, and wherein the seal member includes a material which swells upon contact with a selected fluid so as to move the seal member from the retracted mode to the expanded mode thereof.



WO 03/008756 A1

**WO 03/008756 A1**

---



*For two-letter codes and other abbreviations, refer to the "Guidance Notes on Codes and Abbreviations" appearing at the beginning of each regular issue of the PCT Gazette.*



## WELLBORE SYSTEM WITH ANNULAR SEAL MEMBER

The present invention relates to a wellbore system comprising a borehole extending into an earth formation, a tubular element extending into the borehole whereby a cylindrical wall surrounds the tubular element in a manner that an annular space is formed between the tubular element and the cylindrical wall, and wherein at least one seal member is arranged in said annular space. The cylindrical wall can be formed, for example, by the borehole wall or by another tubular element.

Known seal members are, for example, packers which are arranged in the borehole to seal an annular space between a wellbore casing and a production tubing extending into the borehole. Such packer is radially deformable between a retracted position in which the packer is lowered into the borehole, and an expanded position in which the packer forms a seal. Activation of the packer can be by mechanical or hydraulic means. A limitation of the applicability of such packers is that the seal surfaces have to be well defined.

Another type of annular seal member is formed by a layer of cement arranged in an annular space between a wellbore casing and the borehole wall. Although in general cement provides adequate sealing capability, there are some inherent drawbacks such as shrinking of the cement during hardening resulting in de-bonding of the cement sheath, or cracking of the cement layer after hardening, for example due to pressure and temperature shocks during operation of the well.

63293-3968

- 2 -

In view thereof there is a need for an improved wellbore system which provides adequate sealing of the annular space formed between a tubular element extending into the borehole and a cylindrical wall surrounding the tubular element.

According to one aspect of the present invention, there is provided a wellbore system, comprising a borehole extending into an earth formation; a tubular element extending into the borehole whereby a cylindrical wall surrounds the tubular element in a manner that an annular space is formed between the tubular element and the cylindrical wall; at least one seal member arranged in said annular space, each seal member being movable between a retracted mode in which the seal member has a first volume and an expanded mode in which the seal member has a second volume larger than the first volume, wherein the seal member in the expanded mode thereof seals the annular space, and wherein the seal member includes a material which swells upon contact with a selected fluid so as to move the seal member from the retracted mode to the expanded mode thereof, characterized in that the tubular element has been radially expanded in the borehole.

By bringing the seal member into contact with the selected fluid, the seal member swells and thereby becomes firmly pressed between the tubular element and the cylindrical wall. As a result the annular space becomes adequately sealed, even if one or both of the tubular element and the cylindrical wall are of irregular shape.

Suitably the cylindrical wall is one of the borehole wall and the wall of a casing extending into the borehole.

63293-3968

- 2a -

The system of the invention can also be used in applications wherein the cylindrical wall is the wall of



an outer casing arranged in the borehole, and wherein the tubular element is an inner casing, tubing or liner arranged in the borehole and extending at least partly into the outer casing.

5 To obtain an even better sealing system, it is preferred that the tubular element has been radially expanded in the borehole. In such application the seal member can be, for example, applied to the outer surface of the tubular element before radial expansion thereof so  
10 as to allow easy installation of the tubular element and the seal member in the borehole. Thereafter the tubular element can be radially expanded before or after swelling of the seal member due to contact with the selected fluid. However, to reduce the forces needed to expand the  
15 tubular element it is preferred that swelling of the seal member takes place after expansion of the tubular element.

Suitably the selected fluid is water or hydrocarbon fluid contained in the earth formation.

20 It is preferred that said material of the seal member includes one of a rubber compound, a thermoset compound and a thermoplastic compound. The rubber compound is suitably selected from a thermoset rubber compound and a thermoplastic rubber compound.

25 Examples of suitable thermoset rubbers, which swell when in contact with oil are:

natural rubber, nitrile rubber, hydrogenated nitrile rubber, acrylate butadiene rubber, poly acrylate rubber, butyl rubber, brominated butyl rubber, chlorinated butyl  
30 rubber, chlorinated polyethylene, neoprene rubber, styrene butadiene copolymer rubber, sulphonated polyethylene, ethylene acrylate rubber, epichlorohydrin ethylene oxide copolymer, ethylene-propylene-copolymer



(peroxide cross-linked), ethylene-propylene-copolymer (sulphur cross-linked), ethylene-propylene-diene terpolymer rubber, ethylene vinyl acetate copolymer, fluoro rubbers, fluoro silicone rubber, and silicone rubbers.

5  
A review of thermoset and thermoplastic rubbers and their ability to swell in certain fluids such as hydrocarbon oils can be found in standard reference books such as 'Rubber Technology Handbook', authored by Werner Hofmann (ISBN 3-446-14895-7, Hanser Verlag Muenchen), Chapters 2 and 3. Preferably, one would select rubbers which swell substantially (at least 50 vol%) in hydrocarbons at typical conditions of temperature and pressure as encountered in oil or gas wells, but yet remain integer in a swollen state for enhanced periods of times (i.e. years). Examples of such rubbers are ethylene-propylene-copolymer (peroxide cross-linked) also known as EPDM rubber, ethylene-propylene-copolymer (sulphur cross-linked) also known as EPDM rubber, ethylene-propylene-diene terpolymer rubber also known as EPT rubber, butyl rubber, brominated butyl rubber, chlorinated butyl rubber, and chlorinated polyethylene.

15  
20  
25  
30  
Examples of suitable materials which swell when in contact with water are: starch-polyacrylate acid graft copolymer, polyvinyl alcohol cyclic acid anhydride graft copolymer, isobutylene maleic anhydride, acrylic acid type polymers, vinylacetate-acrylate copolymer, polyethylene oxide polymers, carboxymethyl cellulose type polymers, starch-polyacrylonitrile graft copolymers and the like and highly swelling clay minerals such as Sodium Bentonite (having as main ingredient montmorillonite).

Suitable recipes are for instance disclosed in US Patent 5,011,875 (Corrosion Resistant Water Expandable

Composition), US Patent 5,290, 844 (Water Swelleable Water Stop), US Patent 4,590,227 (Water-Swelleable Elastomer Composition), US Patent 4,740,404 (Waterstop), US Patent 4,366,284, 4,443,019 and 4,558,875 (all  
5 entitled: 'Aqueously-Swelling Water Stopper and a Process of Stopping Water thereby'). The water swelling elastomer compositions are commonly referred to as 'Waterstops' and are commercially available under trade names such as HYDROTITE and SWELLSTOP.

10 The invention will be described hereinafter in more detail and by way of example with reference to the accompanying drawings in which

Fig. 1 schematically shows an embodiment of the wellbore system of the invention; and

15 Fig. 2 schematically shows a detail of Fig. 1.

Referring to Fig. 1 there is shown a wellbore system including a borehole 1 which has been drilled from surface 2 into an earth formation 3. The borehole 1 penetrates an overburden layer 4 and a reservoir zone 6  
20 containing hydrocarbon oil. A layer 8 containing formation water is commonly found below the reservoir zone. The borehole 1 has a substantially vertical upper section 1a extending through the overburden layer 4 and a substantially horizontal lower section 1b extending into  
25 the reservoir zone 6.

A tubular casing string 10 which is formed of a number of casing sections (not shown), extends from a wellhead 12 at surface into the upper borehole section 1a. A further tubular casing string 11 is  
30 provided with a plurality of perforations 15 (for sake of clarity not all perforations have been indicated by a reference numeral) which provide fluid communication between the interior of the casing string 11 and the



exterior thereof. Annular seal assemblies 16, 18, 20, 22, 24 are arranged at selected mutual spacings in an annular space formed 26 formed between the lower casing string 11 and the wall of the lower borehole section 1b.

5 Furthermore, a production tubing 27 extends from the wellhead 12 into the vertical borehole section 1a to a position at or near the transition from the vertical borehole section 1a to the horizontal borehole section 1b. The tubing 27 has an open lower end 28, and  
10 is provided with a seal packer 29 which seals the annular space between the tubing 27 and the casing string 10.

Referring further to Fig. 2 there is shown seal assembly 18 in more detail, the other annular seal assemblies being similar thereto. Annular seal  
15 assembly 18 includes individual seal members 30, 31, 32, 33, 34, each seal member being movable between a retracted mode in which the seal member has a first volume and an expanded mode in which the seal member has a second volume larger than the first volume, whereby the  
20 seal member in the expanded mode thereof seals the annular space 26. Seal members 30, 32, 34 are made of a material which swells upon contact with a hydrocarbon oil so as to move the seal member 30, 32, 34 from the retracted mode to the expanded mode thereof. Seal  
25 members 31, 33 are made of a material which swells upon contact with water so as to move the seal member 31, 33 from the retracted mode to the expanded mode thereof. A suitable material for seal members 30, 32, 34 is, for example, EPDM rubber (ethylene-propylene-copolymer, either sulphur or peroxide cross-linked), EPT rubber  
30 (ethylene-propylene-diene terpolymer rubber), butyl rubber or a halogenated butyl rubber. A suitable material for seal members 31, 33 is for example a thermoset or



thermoplast rubber filled with a substantial (60%) quantity of a water swelleable agent e.g. bentonite, but any of the 'WaterStop' formulations cited above, could be used.

5           During normal use, the vertical borehole section 1a is drilled and the casing sections of casing string 10 are installed therein as drilling proceeds. Each casing section is radially expanded in the vertical borehole section 1a and conventionally cemented therein by means of layer of cement 14. Subsequently the horizontal  
10 borehole section 1b is drilled and lower casing string 11 is installed therein. Before lowering the lower casing string 11 into the borehole 1, the annular seal assemblies 16, 18, 20, 22, 24 are arranged around the  
15 outer surface of the lower casing string 11 at the indicated mutual spacings, whereby each individual seal member 30, 31, 32, 33, 34 of the seal assemblies is in its retracted mode. After installing the lower casing string 11 into the lower borehole section 1b, the lower  
20 casing string 11 is radially expanded to a diameter larger than before such that the seal assemblies 16, 18, 20, 22, 24 are not, or only loosely, in contact with the borehole wall.

          When production of hydrocarbon oil starts, a valve  
25 (not shown) at the wellhead 12 is opened and hydrocarbon oil flows from the reservoir zone 6 into the lower borehole section 1b. The oil flows via the perforations 15 into the lower casing string 11 and from there via the production tubing to the wellhead 12 where  
30 the oil is further transported through a pipeline (not shown) to a suitable production facility (not shown).

          As the oil flows into the lower borehole section 1b, the oil comes into contact with the individual seal

members of each seal assembly 16, 18, 20, 22, 24. The seal members 30, 32, 34 thereby swell and, as a result, move to the expanded mode so as to become firmly pressed between the lower casing part 10b and the borehole wall.

5 In this manner each seal assembly seals the annular space 26 and divides the horizontal borehole section 1b into respective borehole zones 40, 41, 42, 43 whereby zone 40 is defined between seal assemblies 16 and 18, zone 41 is defined between seal assemblies 18 and 20, zone 42 is defined between seal assemblies 20 and 22, and zone 43 is defined between seal assemblies 22 and 24.

After some time it can occur that water from the formation layer 8 enters the horizontal borehole section 1b, for example due to the well-known phenomenon of water coning. To determine the zone of the borehole section 1b where the water flows into the borehole a suitable production logging tool is lowered into the lower casing string 11 and operated. Once the zone of water entry has been determined, for example zone 42, a patch is installed in the lower casing string 11, between seal assemblies 20, 22, so as to close-off the perforations 15 located between seal assemblies 20, 22. A suitable patch is, for example, a length of tube (not shown) which is radially expanded against the inner surface of lower casing string 11. The patch can be clad with a water swelling gasket.

Should the seal members 30, 32, 34 of respective seal assemblies 20, 22 move to their retracted mode due to discontinued contact with hydrocarbon oil, the presence of water in zone 42 ensures that the seal members 31, 33 of seal assemblies 20, 22 swell and thereby move to the expanded mode. It is thus achieved that at least some of the seal members 30, 31, 32, 33, 34 of seal



assemblies 20, 22 seal the annular space 26, irrespective whether oil or water is the surrounding medium.

In an alternative embodiment of the system of the invention, an expandable slotted tubular (EST) (EST is a trademark) liner can be applied instead of the perforated lower casing string 11 referred to above. For example, a  
5 liner with overlapping longitudinal slots as described in US Patent 5366012, could be applied. During radial expansion of the liner, the metal liner parts in-between  
10 the slots behave as plastic hinges so that the slots widen and thereby provide fluid communication between the interior of the liner and the exterior thereof. To isolate selected zones of the borehole from other zones, one or more patches in the form of blank casing sections  
15 can be expanded against the inner surface of the slotted liner. Such blank casing sections are suitably clad with alternating annular seal members of water and hydrocarbon swelling elastomers. In this way it is possible to shut off certain slotted sections of the liner which have  
20 watered out in the course of the life of the well.

In another alternative embodiment of the system of the invention, an expandable sand screen (ESS) (ESS is a trademark), such as described in US 5901789, can be applied instead of the perforated lower casing string 11  
25 referred to above. Again, patches in the form of blank casing sections (preferably clad with hydrocarbon- and/or water-swelleable gaskets) can be expanded against the inner surface of the expandable sand screen to isolate selected zones. Especially in very long parts of  
30 horizontal or multibranch wells, certain sections of the sand screen, which would start producing water ('watered-out') and/or high ratios of gas ('gassed-out') can be isolated in this manner. If no corrective measures would



be taken against such undesirable water or gas production, the well would very rapidly become uneconomical and its ultimate hydrocarbon fluid recovery would be significantly reduced.

5           The ability to shut off watered-out or gassed-out zones of the wellbore allows the Production Engineer to significantly defer the abandonment timing of the well and to maximise the ultimate recovery of the well.

10           Instead of applying the material which swells upon contact with hydrocarbon fluid and the material which swells upon contact with water in separate seal members, such material can be applied in a single seal member. For example, the hydrocarbon swelling ability of an EP(D)M or EPT rubber can be combined with a water swelling ability  
15           of a suitable filler such as e.g. bentonite in a single seal member, such that only one type of packing element with dual functionality is achieved.

63293-3968

- 11 -

CLAIMS:

1. A wellbore system, comprising
  - a borehole extending into an earth formation;
  - a tubular element extending into the borehole5 whereby a cylindrical wall surrounds the tubular element in a manner that an annular space is formed between the tubular element and the cylindrical wall;
  - at least one seal member arranged in said annular space, each seal member being movable between a10 retracted mode in which the seal member has a first volume and an expanded mode in which the seal member has a second volume larger than the first volume, wherein the seal member in the expanded mode thereof seals the annular space, and wherein the seal member includes a material which swells
- 15 upon contact with a selected fluid so as to move the seal member from the retracted mode to the expanded mode thereof, characterized in that the tubular element has been radially expanded in the borehole.
2. The wellbore system of claim 1, wherein the
- 20 cylindrical wall is one of the borehole wall and the wall of a casing extending into the borehole.
3. The wellbore system of claim 1 or 2, wherein the tubular element is one of a perforated casing or liner, an expandable slotted tubular, and an expandable sand screen.
- 25 4. The wellbore system of claim 1, wherein the cylindrical wall is the wall of an outer casing arranged in the borehole, and wherein the tubular element is an inner casing arranged in the borehole and extending at least partly into the outer casing.

63293-3968

- 12 -

5. The wellbore system of any one of claims 1-4, wherein a plurality of said seal members is arranged at selected mutual spacings in said annular space, and wherein each section of the tubular element in-between adjacent seal members is provided with at least one opening providing fluid communication between the interior of the tubular element and the earth formation surrounding the borehole.

6. The wellbore system of claim 5, wherein the borehole includes a substantially horizontal section, and wherein said plurality of seal members is arranged in the substantially horizontal section.

7. The wellbore system of claim 5 or 6, wherein at least one section of the tubular element in-between adjacent seal members is provided with closing means for closing each said opening of the tubular element.

8. The wellbore system of claim 7, wherein said closing means includes a tube arranged in said at least one section of the tubular element, which tube has been radially expanded against the inner surface of tubular element.

9. The wellbore system of any one of claims 1-8, wherein the seal member includes at least one of a material, which swells upon contact with hydrocarbon fluid and a material, which swells upon contact with water.

10. The wellbore system of claim 9, wherein said material of the seal member includes one of a thermoplastic rubber compound and a thermoset rubber compound.

11. The wellbore system of claim 9 or 10, wherein said material of the seal member swells upon contact with hydrocarbon fluid, and is selected from natural rubber, nitrile rubber, hydrogenated nitrile rubber, acrylate



63293-3968

- 13 -

butadiene rubber, poly acrylate rubber, butyl rubber, brominated butyl rubber, chlorinated butyl rubber, chlorinated polyethylene, neoprene rubber, styrene butadiene copolymer rubber, sulphonated polyethylene, ethylene  
5 acrylate rubber, epichlorohydrin ethylene oxide copolymer, ethylene-propylene-copolymer (peroxide cross-linked), ethylene-propylene-copolymer (sulphur cross-linked), ethylene-propylene-diene terpolymer rubber, ethylene vinyl acetate copolymer, fluoro rubbers, fluoro silicone rubber,  
10 and silicone rubbers.

12. The wellbore system of claim 11, wherein said material is selected from EP(D)M rubber (ethylene-propylene-copolymer, either peroxide or sulphur cross-linked), EPT rubber (ethylene-propylene-diene terpolymer rubber),  
15 butyl rubber, brominated butyl rubber, chlorinated butyl rubber, and chlorinated polyethylene.

13. The wellbore system of claim 9 or 10, wherein said material of the seal member swells upon contact with water, and is selected from starch-polyacrylate acid graft  
20 copolymer, polyvinyl alcohol cyclic acid anhydride graft copolymer, isobutylene maleic anhydride, acrylic acid type polymers, vinylacetate-acrylate copolymer, polyethylene oxide polymers, carboxymethyl cellulose type polymers, starch-polyacrylonitrile graft copolymers, highly swelling  
25 clay minerals, Sodium Bentonite having as main ingredient montmorillonite.

14. The wellbore system of any one of claims 1-13, wherein each seal member forms part of a seal assembly which includes at least one other seal member, wherein the seal  
30 member includes a material which swells upon contact with hydrocarbon fluid so as to move the seal member from the retracted mode to the expanded mode thereof, and wherein

. . 63293-3968

- 14 -

said other seal member includes a material which swells upon contact with water so as to move the other seal member from the retracted mode to the expanded mode thereof.

SMART & BIGGAR  
OTTAWA, CANADA

PATENT AGENTS

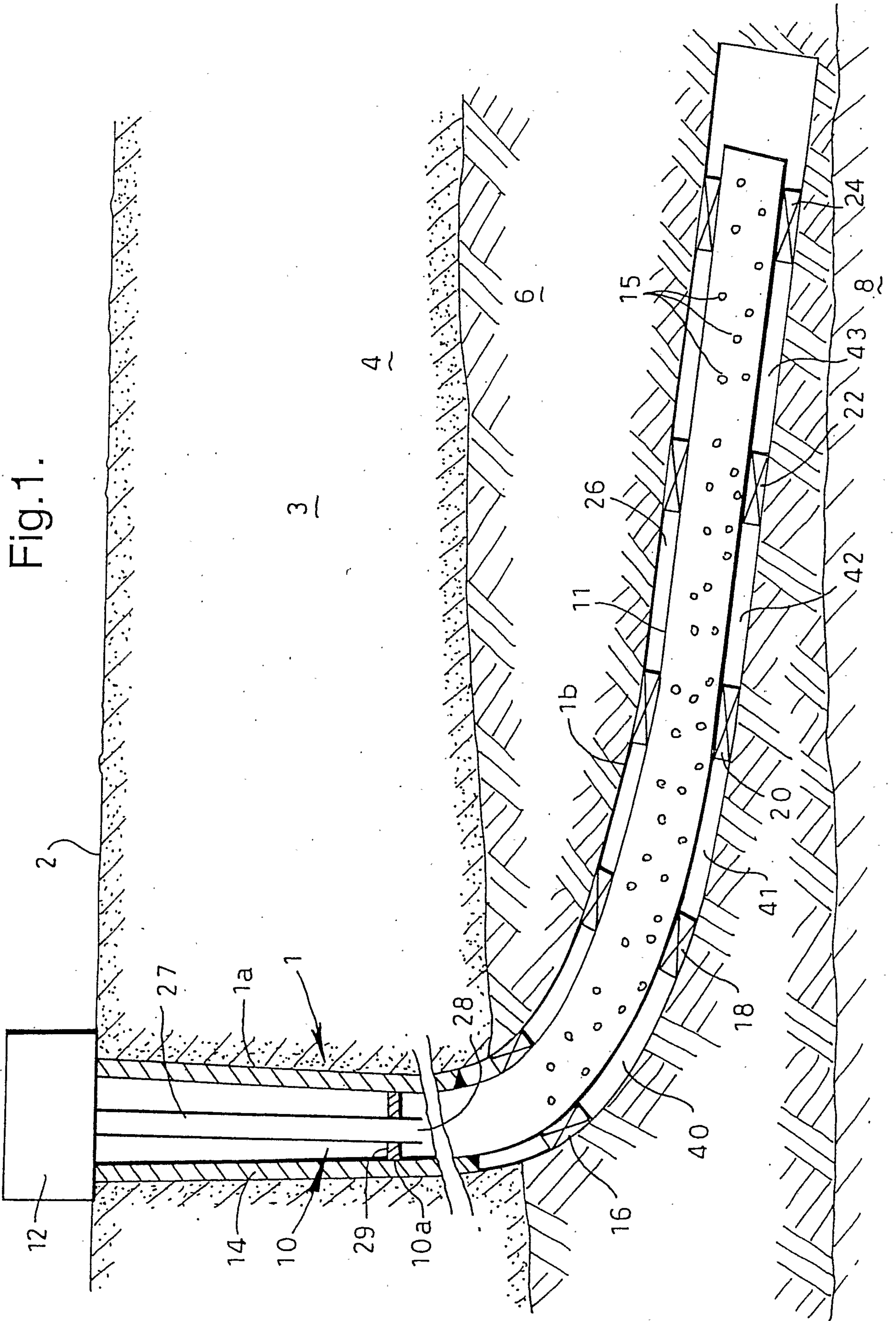



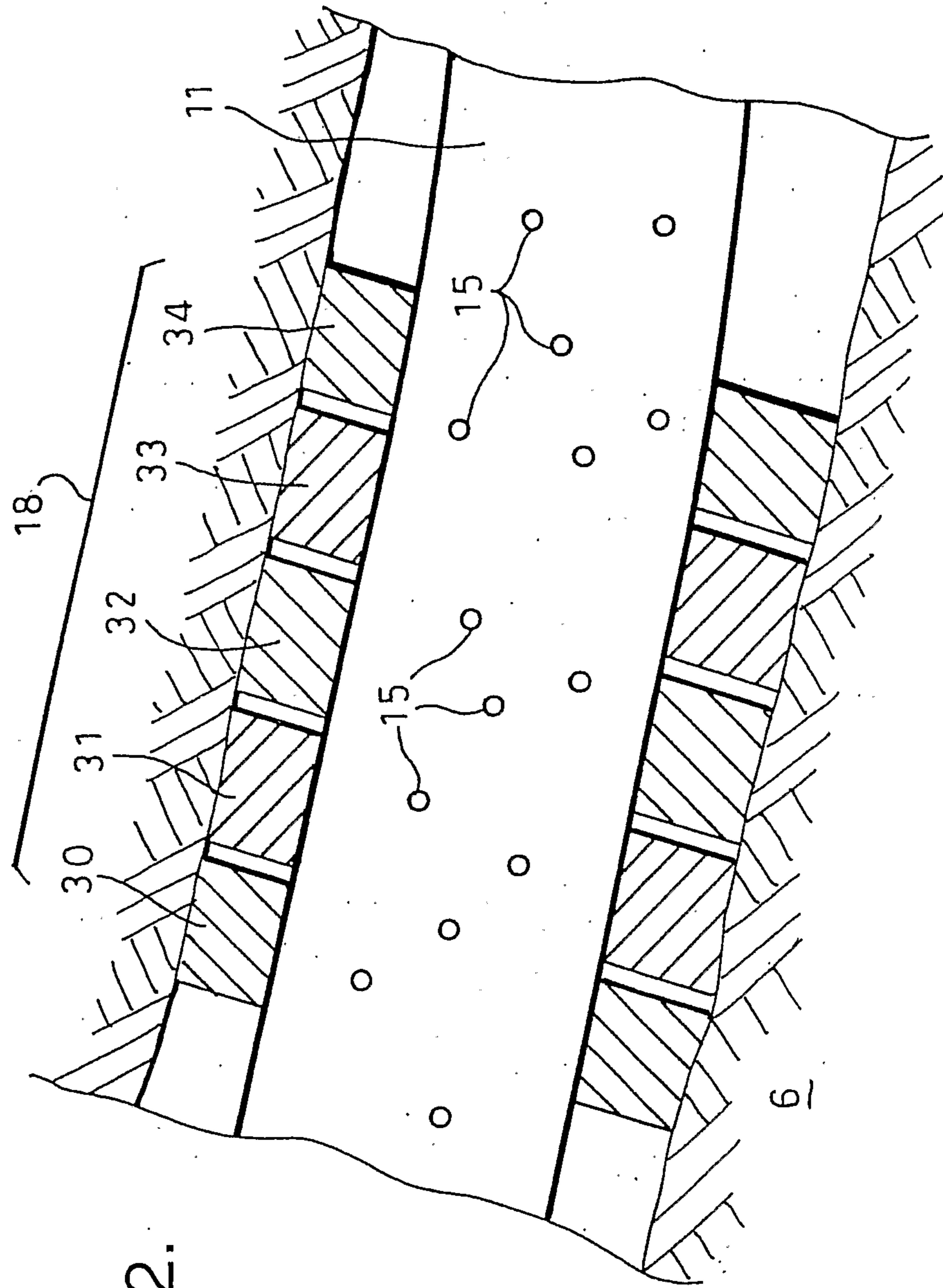

Fig.2.

