



US00D449097B1

(12) **United States Design Patent**
Smith et al.

(10) **Patent No.:** **US D449,097 S**

(45) **Date of Patent:** **** Oct. 9, 2001**

(54) **AIR CLEANER**

D. 462,293 6/2000 Tounsi et al. .
2,638,644 5/1953 Rauhut .
3,948,445 4/1976 Andeweg .

(75) Inventors: **Michael E. Smith**, Glen Allen, VA (US); **Anthony V. Cruz**, Westlake Village, CA (US); **Lawrence M. Pillion**, Glen Allen, VA (US)

(List continued on next page.)

(73) Assignee: **Hamilton Beach/Proctor-Silex, Inc.**, Glen Allen, VA (US)

OTHER PUBLICATIONS

(**) Term: **14 Years**

National Geographic catalog; (approximately Jan. 2001).

(21) Appl. No.: **29/122,711**

Primary Examiner—Lisa Lichtenstein
(74) *Attorney, Agent, or Firm*—Akin, Gump, Strauss, Hauer & Feld, L.L.P.

(22) Filed: **May 1, 2000**

(57) **CLAIM**

(51) **LOC (7) Cl.** **23-04**

The ornamental design for an air cleaner, as shown and described.

(52) **U.S. Cl.** **D23/364**

DESCRIPTION

(58) **Field of Search** D23/364, 355;
46/97

FIG. 1 is a perspective view of the air cleaner.
FIG. 2 is a front view of the air cleaner shown in FIG. 1.
FIG. 3 is a rear view of the air cleaner shown in FIG. 1.
FIG. 4 is a left side view of the air cleaner shown in FIG. 1.
FIG. 5 is a right side view of the air cleaner shown in FIG. 1.

(56) **References Cited**

U.S. PATENT DOCUMENTS

D. 189,420	12/1960	Diehl .	
D. 216,794	3/1970	Patrick .	
D. 234,606	3/1975	Gamble .	
D. 291,484	* 8/1987	Stutzer et al.	D23/364
D. 345,010	3/1994	Aronsson et al. .	
D. 357,330	4/1995	Wong et al. .	
D. 360,028	7/1995	Matsuda .	
D. 374,713	* 10/1996	Ford et al.	D23/264
D. 377,213	1/1997	Wang .	
D. 379,220	5/1997	Ellwood .	
D. 390,940	2/1998	Chen .	
D. 394,100	5/1998	Promseeda .	
D. 395,146	6/1998	Miller et al. .	
D. 396,275	7/1998	Pearson .	
D. 399,943	10/1998	Ko .	
D. 400,661	11/1998	Ko .	
D. 400,662	11/1998	Davis .	
D. 409,741	5/1999	Yuen-Ming .	
D. 411,001	6/1999	Pinchuk .	
D. 416,318	11/1999	Sato .	
D. 416,319	11/1999	Rollins .	
D. 416,613	11/1999	Bellil et al. .	
D. 434,483	* 11/2000	Pinchuk	D23/364

FIG. 6 is a top plan view of the air cleaner shown in FIG. 1.
FIG. 7 is a bottom plan view of the air cleaner shown in FIG. 1.

FIG. 8 is a perspective view of the air cleaner showing a second embodiment of our new design.

FIG. 9 is a front view of the air cleaner shown in FIG. 8.
FIG. 10 is a rear view of the air cleaner shown in FIG. 8.
FIG. 11 is a left side view of the air cleaner shown in FIG. 8.

FIG. 12 is a right view of the air cleaner shown in FIG. 8.
FIG. 13 is a top plan view of the air cleaner shown in FIG. 8; and,

FIG. 14 is a bottom plan view of the air cleaner shown in FIG. 8.

The broken line showing of environmental structure in FIGS. 8–14 is for illustrative purposes only and forms no part of the claimed design.

1 Claim, 12 Drawing Sheets

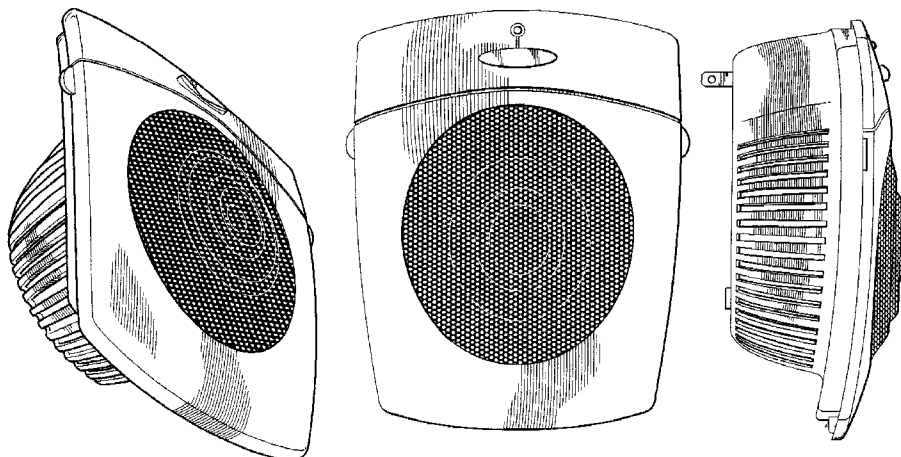

U.S. PATENT DOCUMENTS					
			5,378,254	1/1995	Maly et al. .
			5,407,469	4/1995	Sun .
4,004,361	1/1977	McVeety .	5,547,615	8/1996	Jané et al. .
4,040,568	8/1977	Mason, Jr. et al. .	5,601,636	2/1997	Glucksman .
4,118,191	10/1978	Böhnensieker .	5,611,967	3/1997	Jane et al. .
4,210,429	7/1980	Golstein .	5,735,918	4/1998	Barradas .
4,214,146	7/1980	Schimanski .	5,772,732	6/1998	James et al. .
4,666,638	5/1987	Baker et al. .	5,783,117	7/1998	Byassee et al. .
4,737,173	4/1988	Kudirka et al. .	5,792,230	8/1998	Moore et al. .
4,743,406	5/1988	Steiner et al. .	5,800,583	9/1998	Pippel et al. .
4,839,014	6/1989	Park et al. .	5,800,741	9/1998	Glenn et al. .
4,849,862	7/1989	Diskin et al. .	5,811,004	9/1998	Robertson .
4,917,862	4/1990	Kraw et al. .	5,837,207	11/1998	Summers .
4,931,224	6/1990	Holzner, Sr. .	5,879,435	3/1999	Satyapal et al. .
5,014,338	5/1991	Glucksman .	5,925,320	7/1999	Jones .
5,111,529	5/1992	Glucksman .	5,945,038	8/1999	Anderson .
5,139,546	8/1992	Novobilski .	5,948,355	9/1999	Fujishima et al. .
5,210,818	5/1993	Wang .	5,997,619	12/1999	Knuth et al. .
5,240,478	8/1993	Messina .	6,017,375	1/2000	Duell et al. .
5,250,232	10/1993	Pepper et al. .	6,036,757	3/2000	Gatchell et al. .
5,266,004	11/1993	Tsumurai et al. .			
5,330,722	7/1994	Pick et al. .			

* cited by examiner

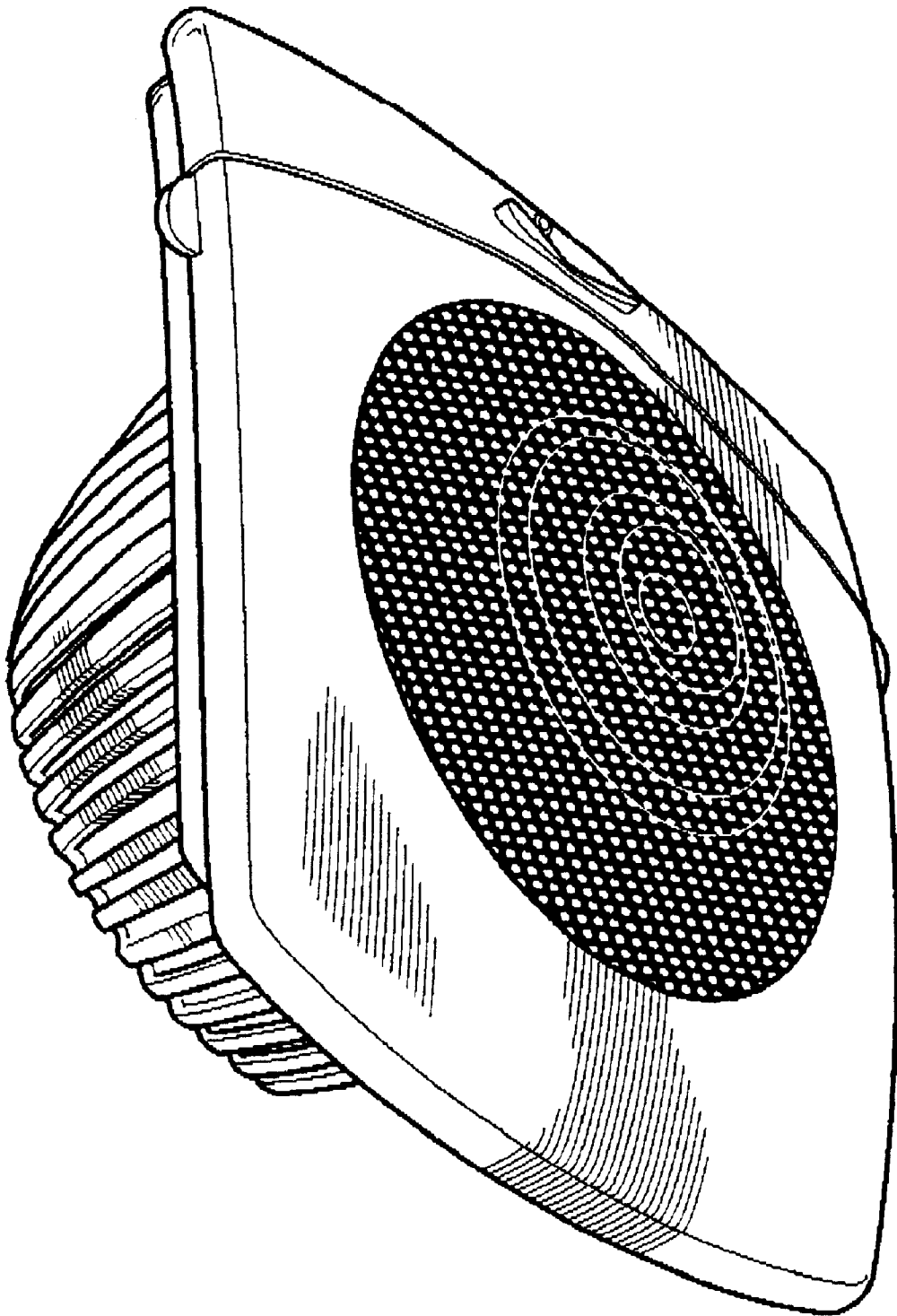

Fig. 1

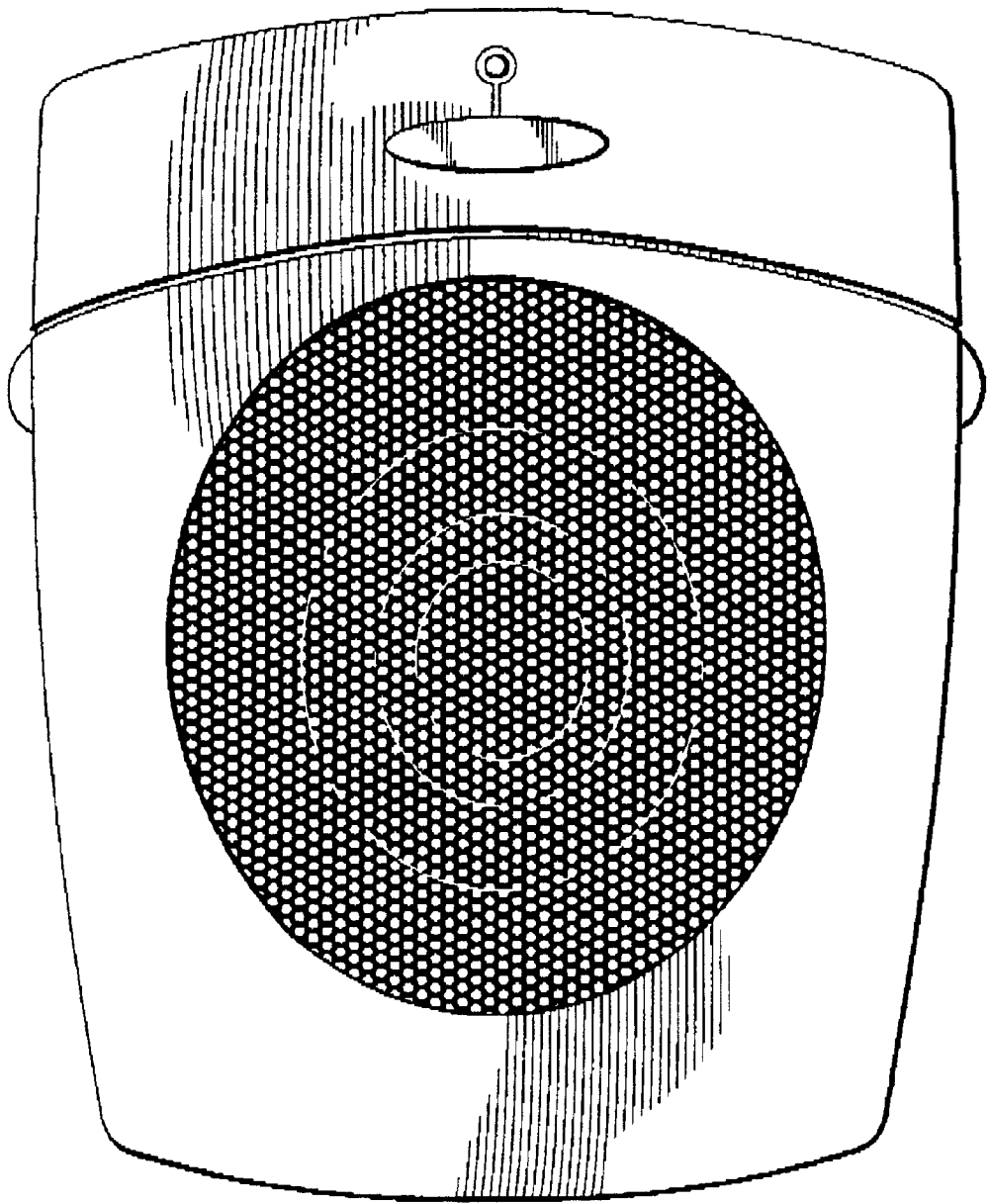

Fig. 2

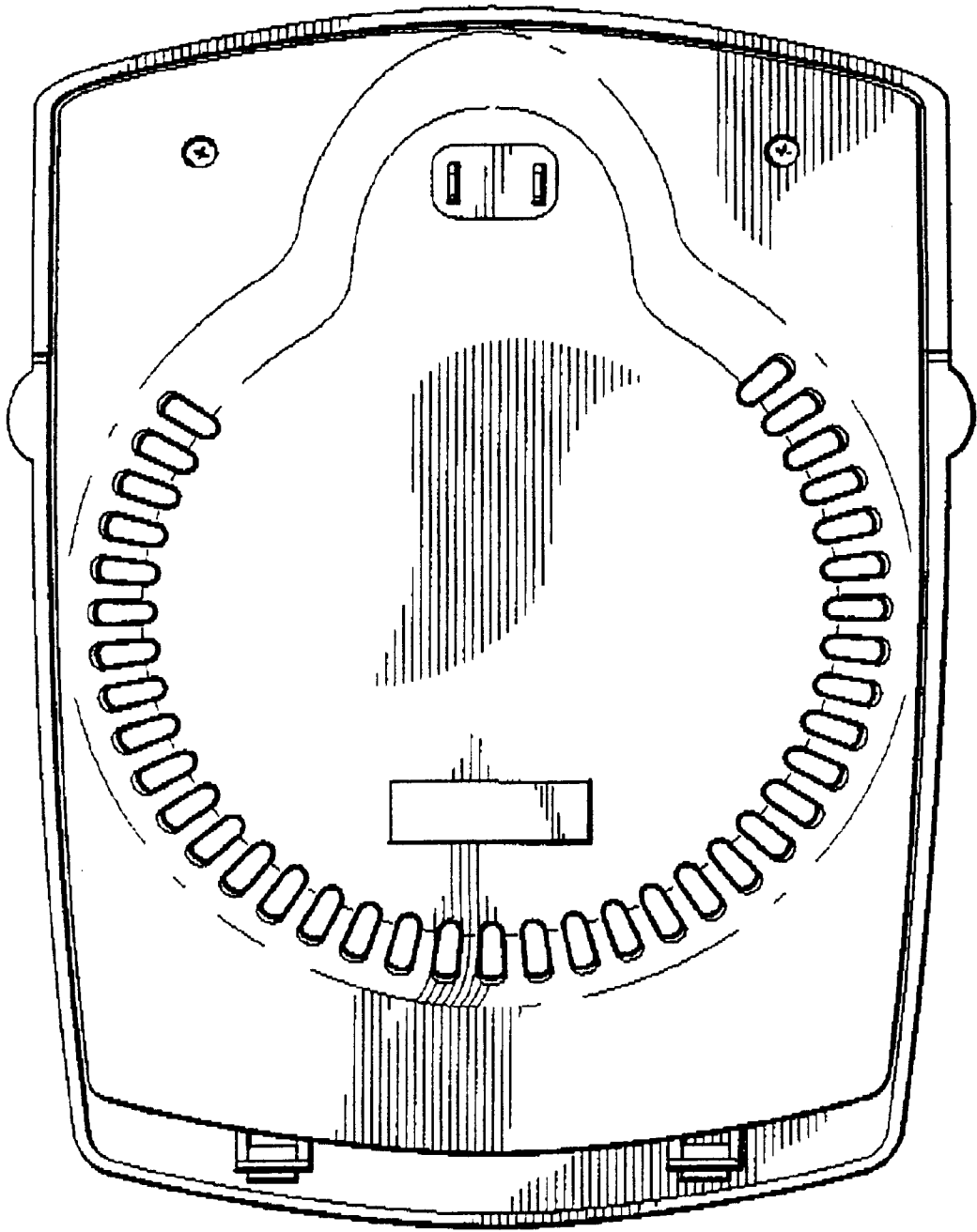

Fig. 3

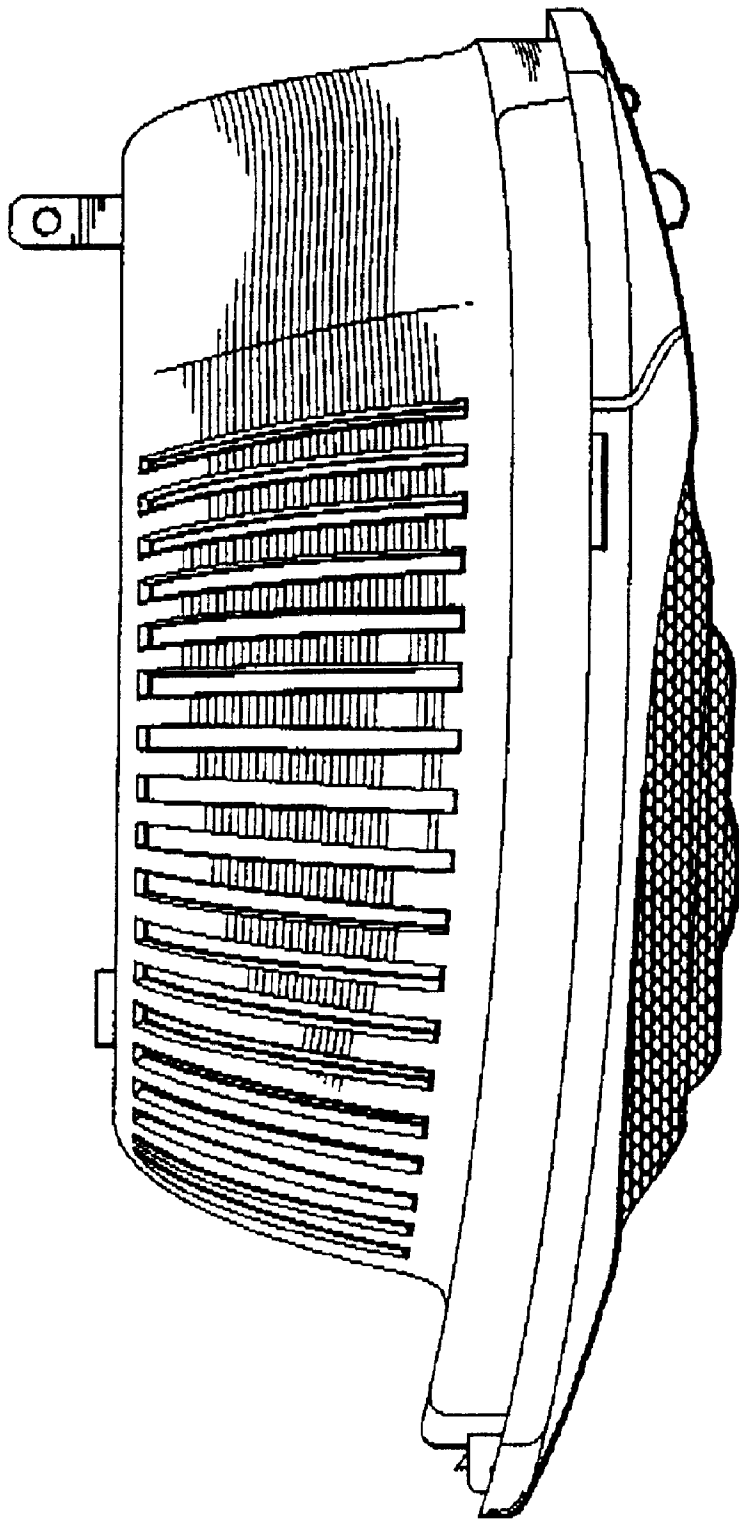

Fig. 4

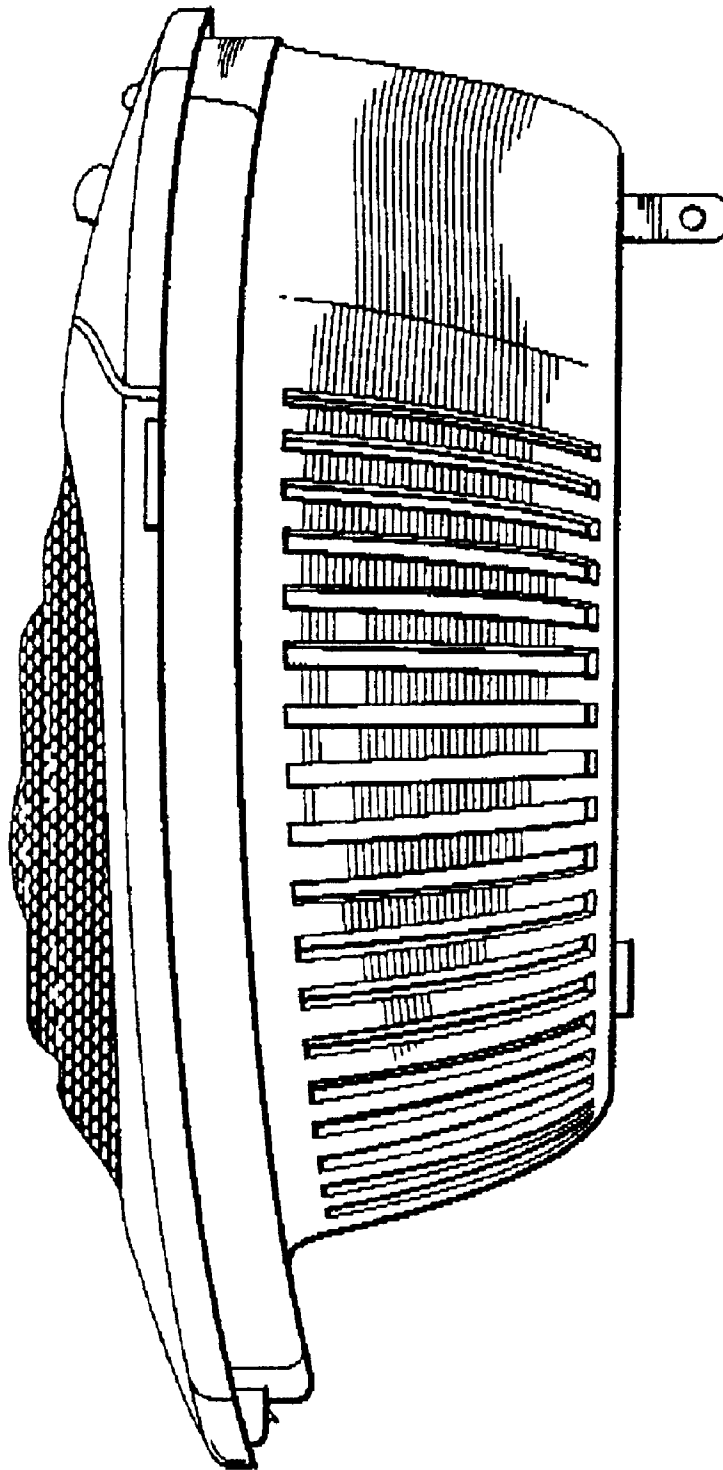

Fig. 5

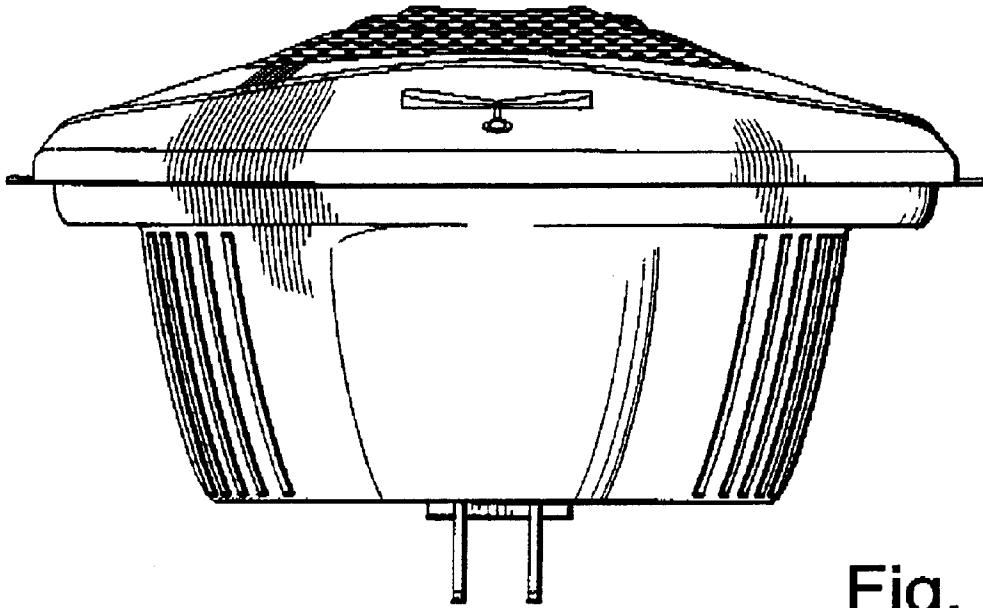

Fig. 6

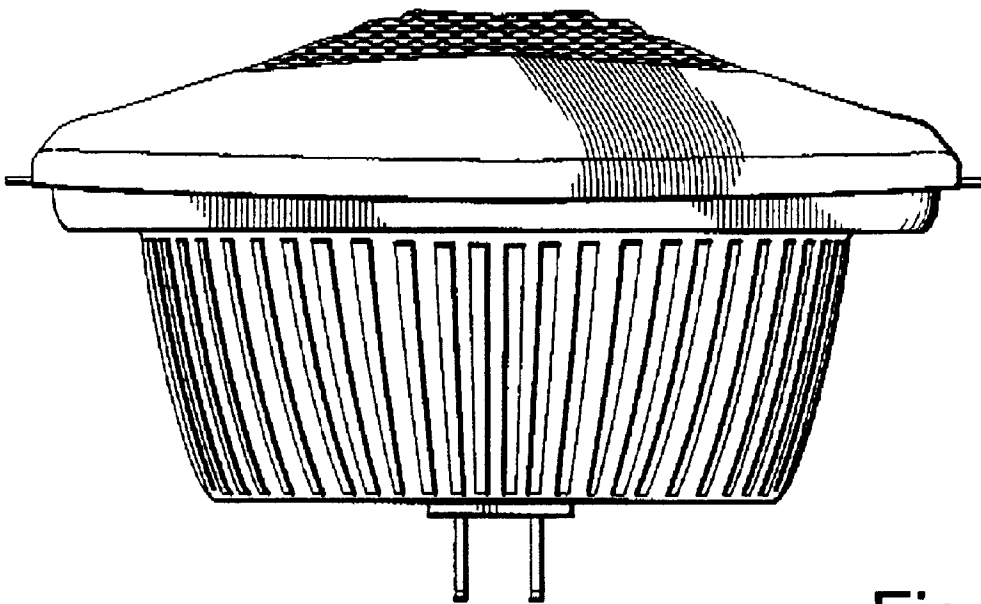

Fig. 7

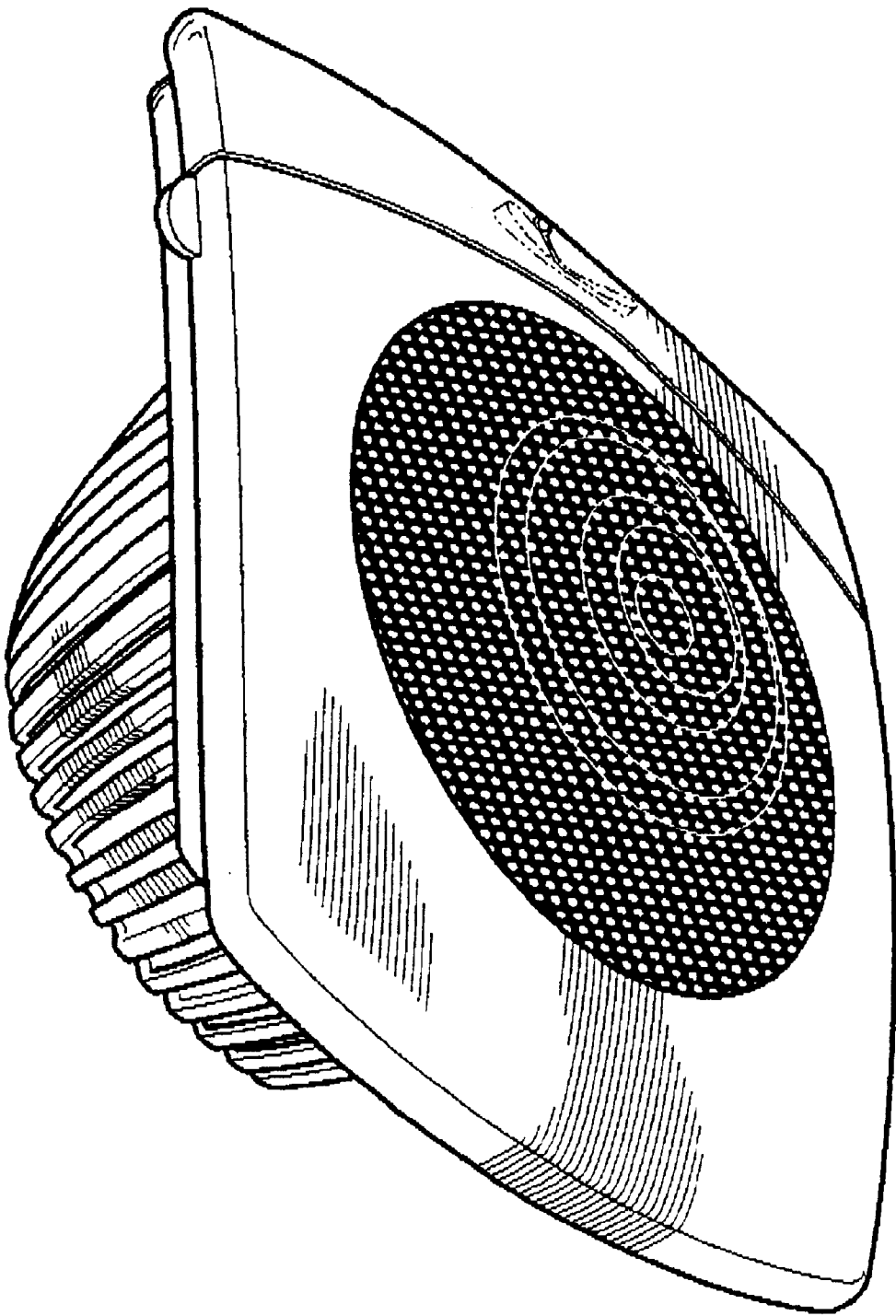

Fig. 8

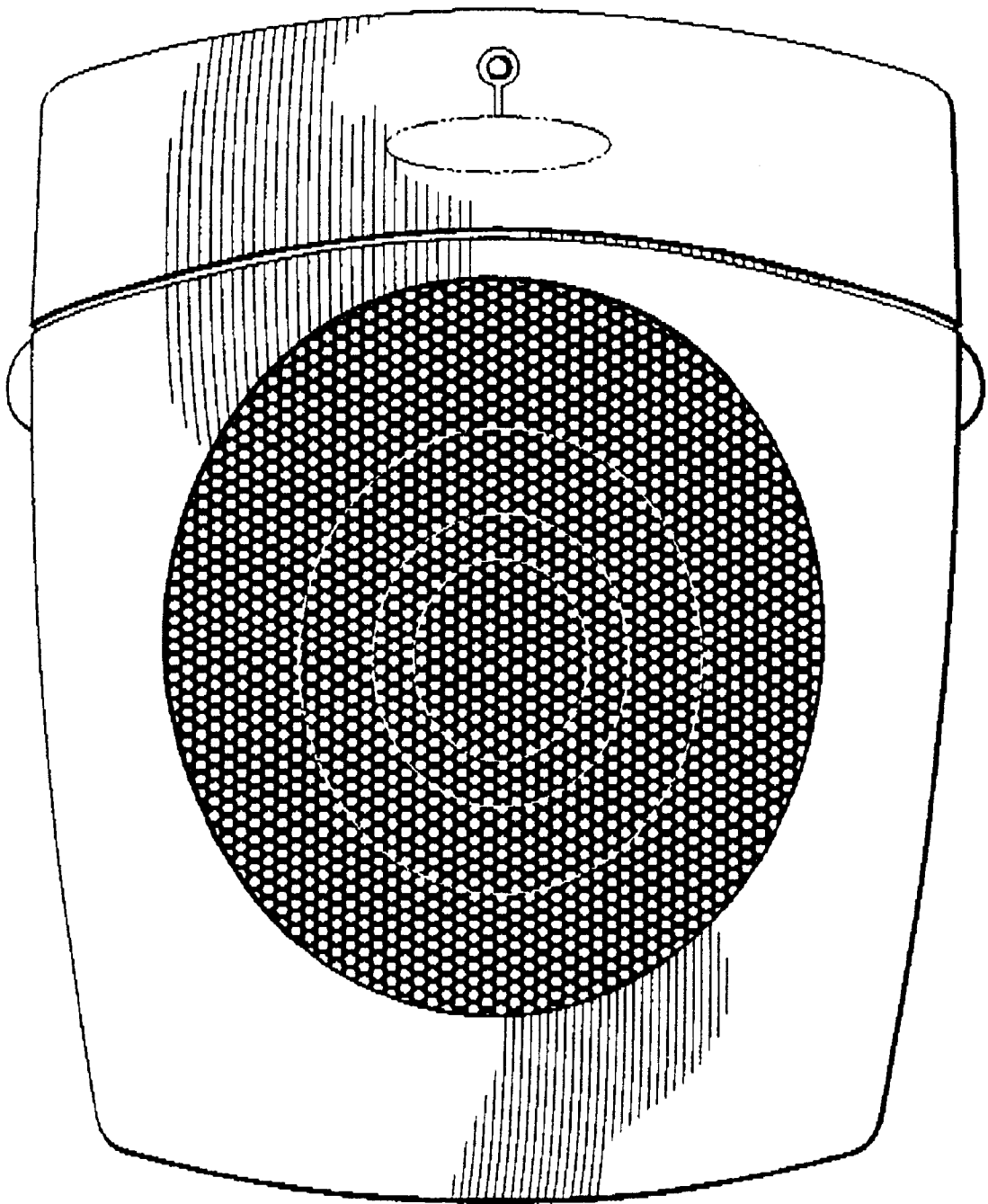

Fig. 9

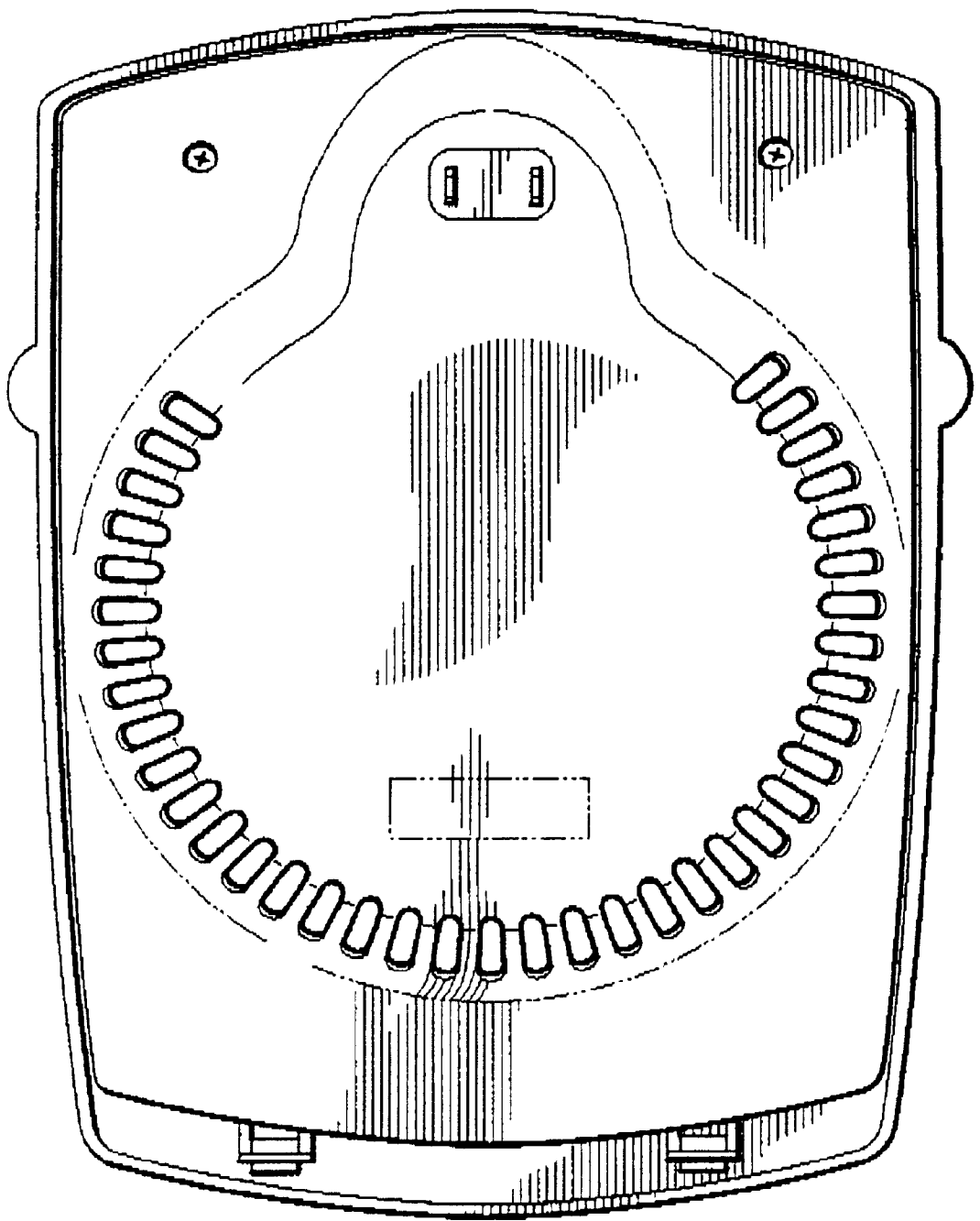

Fig. 10

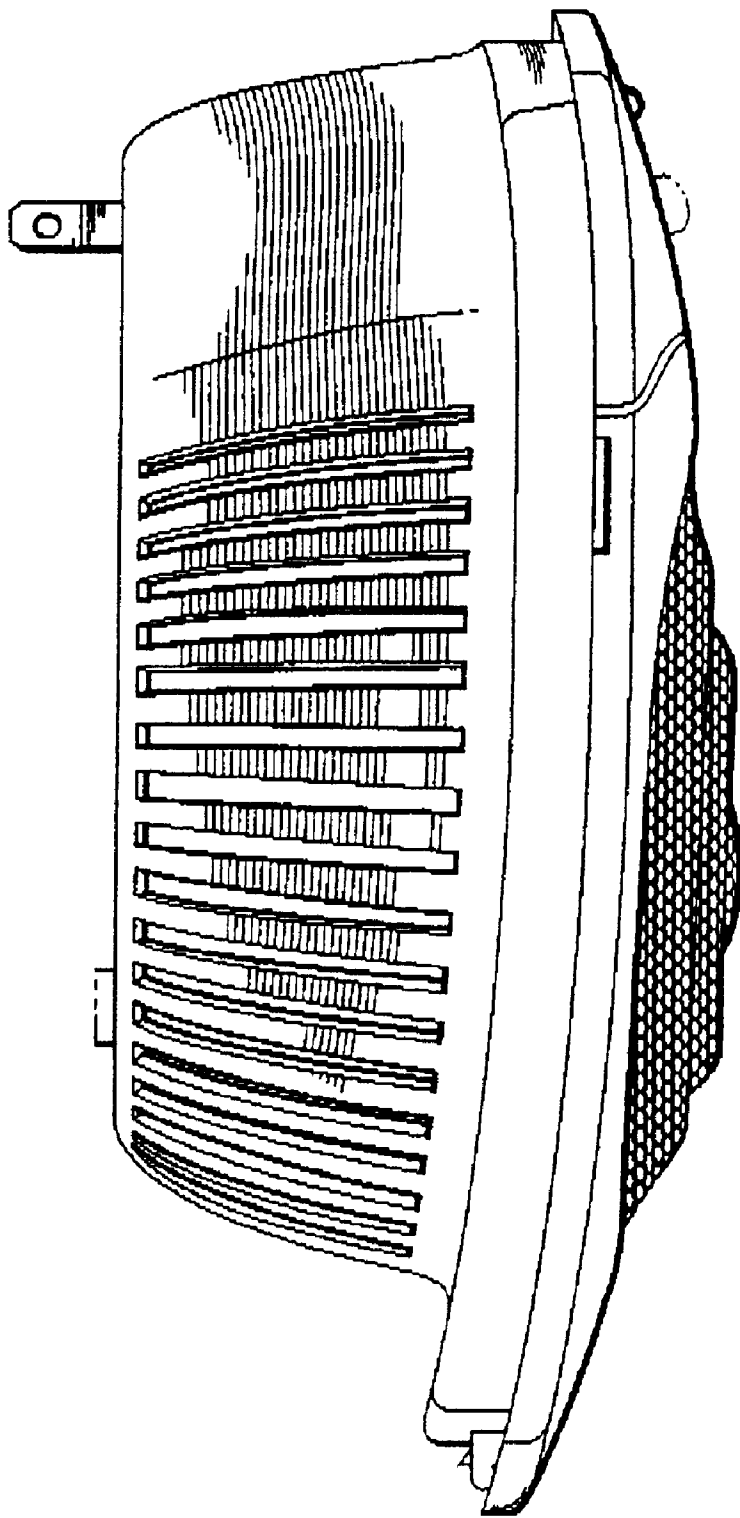

Fig. 11

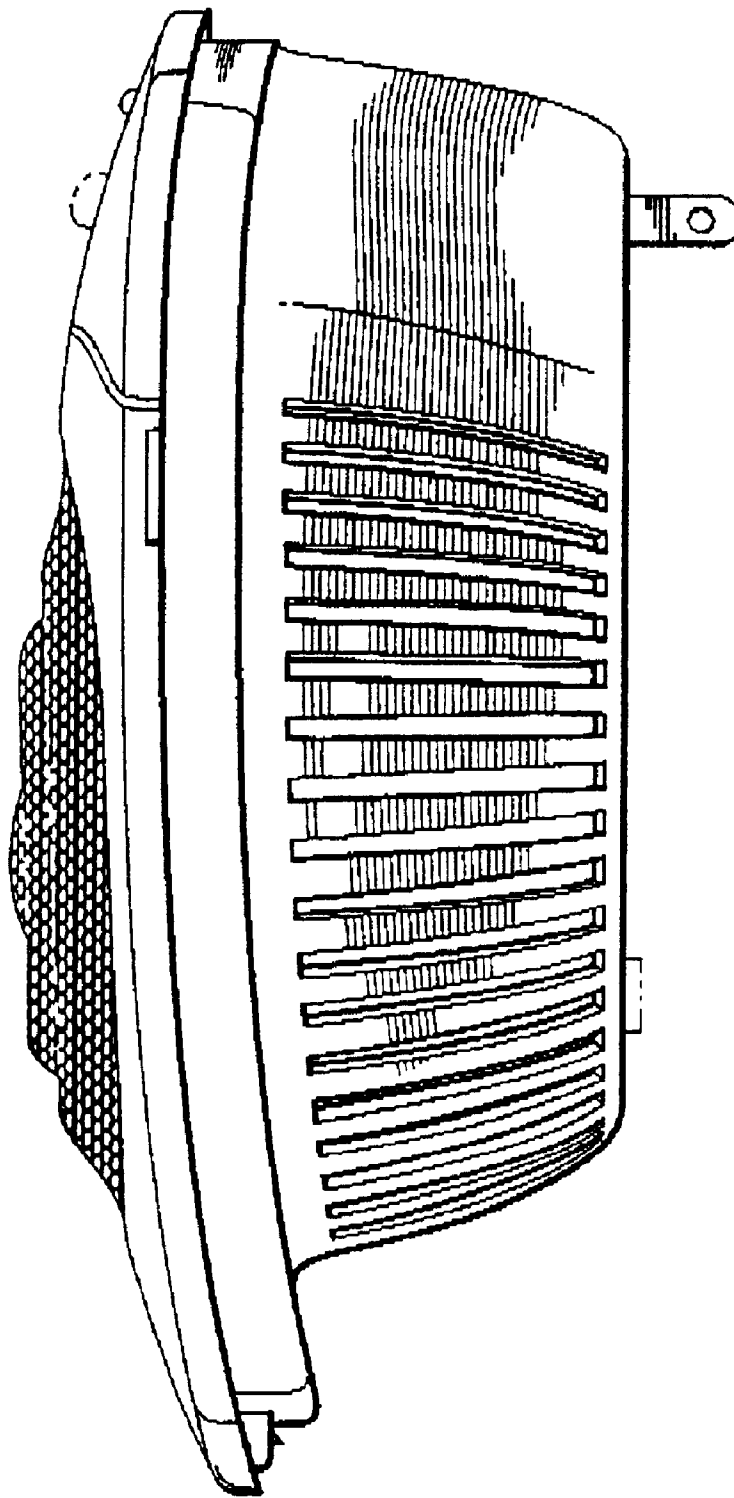

Fig. 12

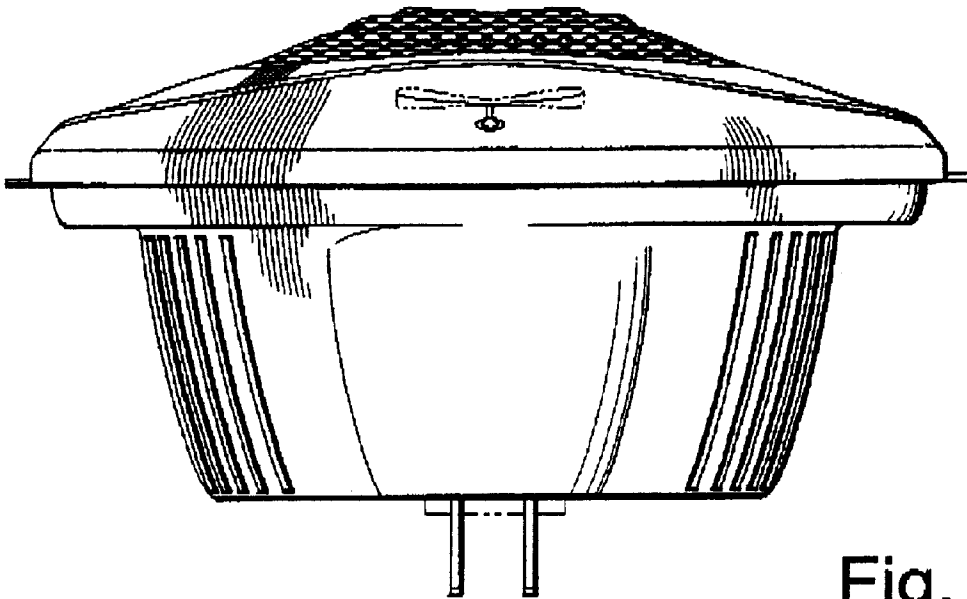

Fig. 13

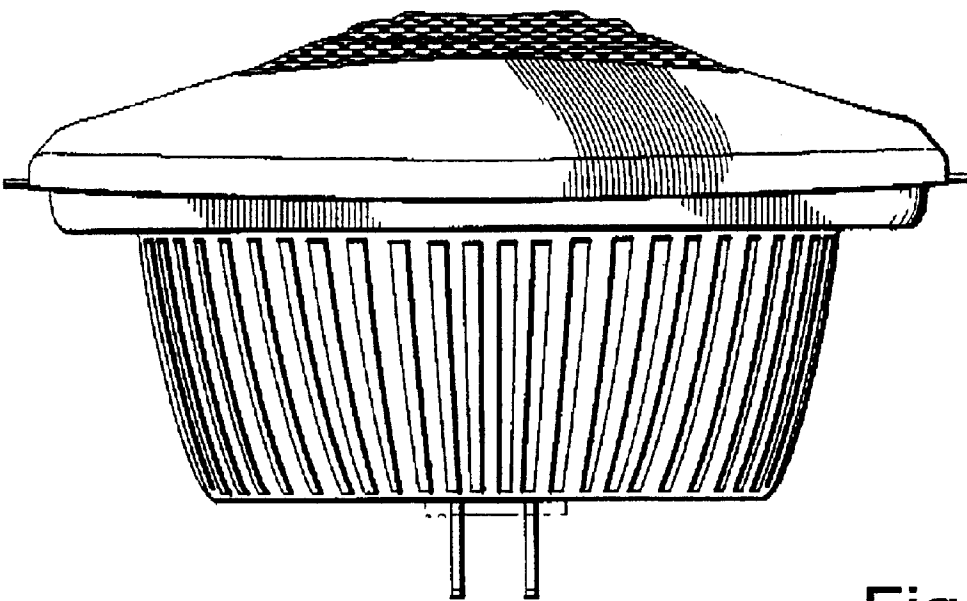

Fig. 14