



(stoma)

(pouch)

(pinch)

9 A D

(便)

, 1

가

가

가

가

가

(heat seal),

가

(heat cut)

가

가

(medium)

(增設)

가

1

2

(sealer)

3

가

4

5

가

6

7

(impulse heat sealer)

8

9



가 , 1

7

(剛性) 가 (4)

(24) 가 (力點) (挾壓)

(25)

가

(heat seal), (heat cut) 26

7 (lock) (clamp, 27) (lever)

가 (挾壓力)

가 2 100V 12V 15cm

가 8

A -

B -

C - (消臭劑) 6 B (vanish)

D - B 2

E -

25 가 60% 3 50g, XP-329 , 200

가 50cm (所用)

3 6

0 -

1 -

2 -

3 -

4 -

5 -

8 , E , A D

. 가 , E , 가 .

가

가 (seal) , 가  
가 가 , , 가

( )

가 가 가 ,  
가

(57)

1. 가 가 (seal) , (seal)

2. , 1 가 가 , 1 가

3. 1 , (seal) 가 , 가 4 (seal line)  
가

4. , 2 2

5. 가 (medium) , ,  
(heat seal)

1

6.

, 가 (支點) 가 (力點), 가, 가

7.

6

, (lock) (clamp) 6

8.

7

, 가 , 가가

9.

6

, 가

(pouch)

가

pulse heat sealer) 가

(im

2

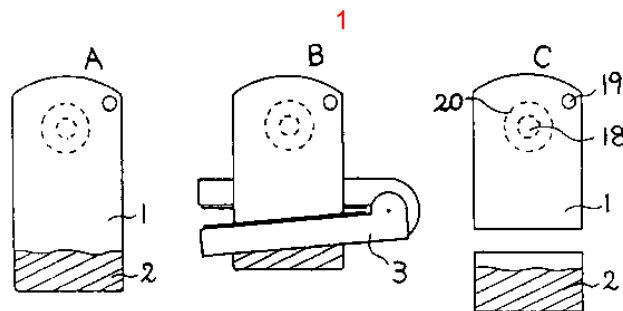

2

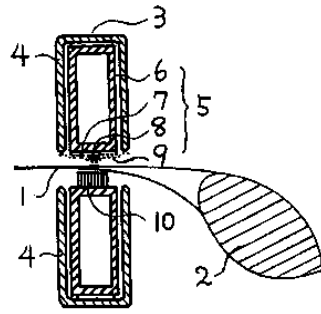

3

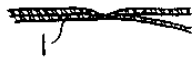

4

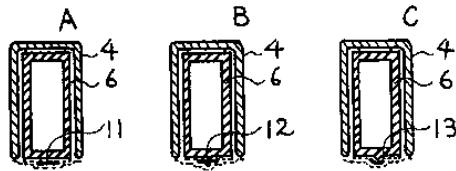

5

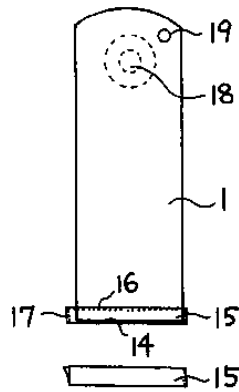

6

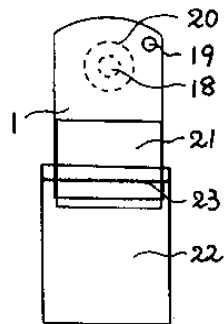

7

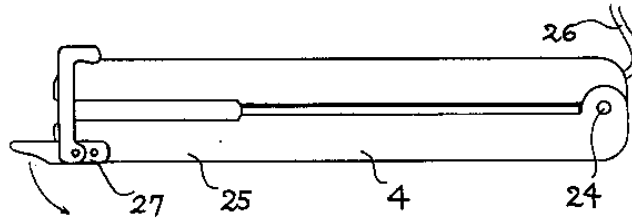

8

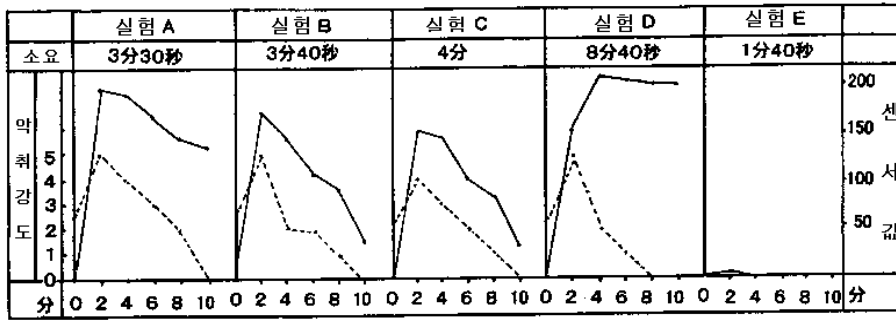

갈아입음 용지 (규격 26)

9

