

(19)



(11)

**EP 3 228 809 B1**

(12)

**EUROPEAN PATENT SPECIFICATION**

(45) Date of publication and mention of the grant of the patent:  
**05.12.2018 Bulletin 2018/49**

(51) Int Cl.:  
**E21B 7/06 (2006.01)**

(21) Application number: **16164116.2**

(22) Date of filing: **06.04.2016**

(54) **STEERING JOINT FOR A STEERABLE DRILLING SYSTEM**

LENKVERBINDUNG FÜR EIN LENKBARES BOHRSYSTEM

JOINT DE DIRECTION POUR UN SYSTÈME DE FORAGE ORIENTABLE

(84) Designated Contracting States:  
**AL AT BE BG CH CY CZ DE DK EE ES FI FR GB GR HR HU IE IS IT LI LT LU LV MC MK MT NL NO PL PT RO RS SE SI SK SM TR**

(43) Date of publication of application:  
**11.10.2017 Bulletin 2017/41**

(73) Proprietor: **Hawle Water Technology Norge AS**  
**1340 Skui (NO)**

(72) Inventors:  
• **Borgen, Harald**  
**3189 Horten (NO)**  
• **Solberg, Pål**  
**3290 Stavern (NO)**

• **Kopanos, Stylianos**  
**3179 Åsgårdstrand (NO)**

(74) Representative: **Puchberger & Partner**  
**Patentanwälte**  
**Reichsratsstraße 13**  
**1010 Wien (AT)**

(56) References cited:  
**EP-A1- 1 923 534 GB-A- 2 026 063**  
**US-A- 3 743 034 US-A- 4 813 497**  
**US-A- 5 232 058 US-A- 5 474 334**  
**US-A1- 2005 098 350 US-A1- 2011 140 411**  
**US-A1- 2014 251 695 US-A1- 2014 262 530**

**EP 3 228 809 B1**

Note: Within nine months of the publication of the mention of the grant of the European patent in the European Patent Bulletin, any person may give notice to the European Patent Office of opposition to that patent, in accordance with the Implementing Regulations. Notice of opposition shall not be deemed to have been filed until the opposition fee has been paid. (Art. 99(1) European Patent Convention).

**Description**

**[0001]** The invention relates to a steering joint, particularly to a steering joint for a steerable drilling system, and a steerable drilling system comprising such a steering joint.

**[0002]** Horizontal drilling devices are used to introduce supply and disposal lines into the ground in trenchless construction or to exchange already installed lines in a trenchless manner. Common are horizontal drilling devices in which a drill head is initially advanced into the ground by means of a drill rod assembly, and is later redirected into a horizontal position. The target point for such a horizontal drilling can be located under ground level, for example in an excavation pit, a maintenance shaft of a sewage line, or in the basement of a house. Alternatively, the drill head might be redirected into a vertical direction to let it reemerge above ground. After the drill head has reached the target point, it is often replaced by a widening device such as a conical widening body to widen the previously generated bore or to completely remove an already installed conduit.

**[0003]** US patent US 5 232 058 discloses a steering joint, comprising an upper tubular and a lower tubular connected by a universal joint, which allows the upper tubular to bend with respect to the lower tubular, the universal joint comprising a joint-bearing socket with a hollow core and a cylindrical and rotatable step piston with a hollow core. The joint-bearing socket and the step piston indirectly interact by radially placed cams and grooves.

**[0004]** US 2014/0251695 A1, US 4 813 497, US 2014/0262530 A1, and US 5 474 334 describe steering joint arrangements for drilling devices comprising axial cams and radial grooves on ring-shaped face ends of certain functional elements. An adjustment of the steering joints may be performed either manually on the surface, or remotely using pistons. A tilt between two tubulars is obtained by the relative rotation between two angled end faces. Cams and grooves serve the function of transmitting rotation and prevent misalignment of the two angled surfaces.

**[0005]** A different type of a steering joint is disclosed in US 3 743 034, EP 1 923 534 A1, and US 2005/0098350 A1. These prior art documents disclose steering joints, where rods or other elements apply force to parts of a tubular end face, which leads to a tilt of the tubular.

**[0006]** US 2011/0140411 A1 describes a steering joint comprising an interlocking mechanism with means to adjust the angular orientation between two tubulars. GB 2 026 063 A discloses another steering joint assembly comprising a guide finger and a corresponding groove to alter the angle between two tubulars.

**[0007]** A problem of existing steerable drilling systems is, that these are propelled through the ground either by rotating the drill head, or by pushing the drill head, for example using a hammer or stroke device. The forward thrust is usually provided to the drill head over the drill string from outside of the drilled hole, which might be problematic due to limited space in horizontal drilling applications. A further problem of existing drilling systems is, that the torque lock for systems based on a drilling head, which creates strong torque on the drill string, is usually achieved by mechanical means, which are often not easy to handle. A further problem of existing drilling systems is, that in order to allow the steering of the drill head, such systems comprise asymmetrically shaped drill heads, which are for example slanted. Such drill heads will be laterally deflected into the desired direction when pushed forward without rotation. When the drill head is rotated, the asymmetric configuration has no influence on the straight drilling course. However, propulsion by means of hammering requires a stiff drill string in order to transfer the force onto the drill head, which therefore limits the bending radius of the drilled bore.

**[0008]** A further problem of existing drilling systems is, that the driving motor of the drill head is usually arranged outside of the drilled hole, so that the drill force is transferred over a drill string to the drill head.

**[0009]** However, this makes the drilling of small radii difficult or impossible. A further problem of existing drilling systems is, that the drilled hole might not be stable enough to easily insert a tubular member, such as a commonly used protection pipe, into the drilled hole. If the tubular member such as a protection pipe is pulled by the drill head assembly into the drilled hole, the problem arises, that the protection pipe is subject to heavy mechanical abrasion and shearing. A further problem of existing drilling systems is, that commonly used hydraulic motors to drive the drill head involve the deliberate offset of the rotational center of the rotor with respect to the geometrical center of the outer case, where vanes move radially out from the rotational center of the rotor. This causes several problems. First, the pressure unbalance caused by the hydraulic-based force on the radial cross-section of the rotor and vanes at the axis viewed from the radial perspective severely limits the power capability and power density of these pumps and results in heavy, inefficient, and cumbersome devices. Second, the centrifugal force of each vane during high speed rotation causes severe wear of the vane outer edge and the inner surface of the outer containment housing.

**[0010]** It is an object of the invention to solve these problems and propose improvements in different aspects of drilling systems, which are particularly useful for, but not limited to, horizontal steerable drilling systems. It is a further object of the invention to propose a steerable drilling system comprising all or any of the proposed improvements.

**[0011]** These and other problems are solved by a steering joint comprising an upper tubular and a lower tubular connected by a universal joint which allows the upper tubular to bend with respect to the lower tubular, and wherein the universal joint comprises a joint bearing socket with a hollow core, comprising axially protruding cams with identical extension on a substantially ring-shaped face end, a cylindrical and rotatable step piston with a hollow core and radial

grooves on a substantially ring-shaped face end. The cams and the grooves are arranged in such a way to provide a positive force-fitting connection of the bearing socket with the step piston.

5 [0012] The grooves are of different depth and their bases define inclined planes with respect to the plane of the face end of the step piston, so that the upper tubular and the lower tubular can be tilted with respect to each other at predefined steering angles.

10 [0013] According to a further aspect of the invention, on the face end of the step piston, preferably at least three grooves are arranged in specific inclined planes of different angles at each of preferably four predefined rotational steps of the step piston, so that four rotational steps result in at least twelve inclination steps of the axis of the lower tubular with respect to the axis of the upper tubular. Particularly, four steering angles of 0°, 90°, 180°, and 270° and three grooves arranged in inclined planes of 0°, 4°, and 8° with respect to the plane of the face end of the step piston can be predefined, wherein each groove is placed at a center angle of 30° from the neighboring grooves. The grooves can be provided with such depths that these inclination angles over the plane of the face end of the step piston are achieved.

15 [0014] According to a further aspect of the invention, the steering joint comprises a tubular pin keeper which is coupled to axial groove tracks on the outer surface of the bearing socket, so that the upper tubular and the lower tubular are rotationally locked to each other.

20 [0015] The step piston can be rotatable by a hydraulic or electric motor, such as, for example, a stepper motor. In a possible embodiment, the step piston is axially movable by a force, such as a hydraulic force, and is equipped with wedged tracks on its outer circumference, wherein the wedged tracks are engaged by counter holding pins fixed or connected to the lower tubular, so that an axial movement of the step piston causes a rotation of the step piston with respect to the lower tubular, and a return force is provided by a mechanical spring arranged between the step piston and an inner face of the lower tubular.

25 [0016] According to a further aspect of the invention, the step piston is coupled to at least one circumferential and ring-section-shaped hydraulic piston which is held in an annular rotator housing by means of a carrier in such a way, that it can be moved in a stepwise fashion in the rotator housing by means of applying a hydraulic medium, and a stepwise rotation of the hydraulic piston results in a stepwise rotation of the step piston.

30 [0017] According to a further aspect of the invention, at least one carrier engages with axial oriented wedged tracks on the outer surface of the step piston in order to rotationally couple the step piston to the hydraulic piston. According to a further aspect of the invention, the hydraulic piston covers a ring section of typically 20° to 40°, preferably 30° of the circumference of the step piston.

35 [0018] According to a further aspect of the invention, the hydraulic piston is equipped with an elastic return element, such as a return spring to pull the hydraulic piston back after each rotation step, so that a ratchet-type oscillation of the hydraulic piston with respect to the rotator housing is achieved.

[0019] According to a further aspect of the invention, at least one elastic element, such as an axial spring is provided on the outer surface of the step piston and is pushing against an axial bearing carrier in order to exert a return force on the step piston.

[0020] According to a further aspect of the invention, the universal joint is released to freely bend in any direction when there is no pressure force on the step piston in order to pull back the steering joint after operation.

[0021] According to a further aspect of the invention, the rotational position of the step piston and/or the steering orientation of the lower tubular with respect to the upper tubular is measured by an electric or magnetic sensor.

40 [0022] The invention further relates to drilling systems, particularly steerable drilling systems, comprising a steering joint according to the invention. The invention further relates to drilling systems, particularly steerable drilling systems, further comprising a hydraulic motor, a protection sleeve, a counter hold system, a drill head with a crushing system, and/or a magnetic propulsion system as outlined below.

45 [0023] Further aspects of the invention are described in the claims, the figures and the description of the embodiments. The following description of non-limiting embodiments details several independent aspects of a proposed drilling system with a steering joint according to the invention. However, the invention is not limited to the proposed embodiments.

50 [0024] Fig. 1 shows a first embodiment of a steerable drilling system comprising a steering joint according to the invention. The drilling system comprises a drill head 1 which is connected to a hydraulic motor 2. The hydraulic motor 2 is connected to a steering joint 3 which enables to steer the drill head 1 in the desired direction. The steering joint 3 is connected to a counter hold system 4 which is used to provide the counter torque to push the drill head 1 forward. The hydraulic motor 2 is placed in front of the steering joint 3, so that the use of a drive shaft through the steerable joint is avoided. The counter hold system 4 is connected to a tubular member 5 such as a protection pipe, which is followed by a protection sleeve 6. The whole drill system is introduced into the ground through a hole 10 in the wall 7 by means of an entrance arrangement 8, such as an entrance bracket, which is provided at the hole 10 of the wall 7 or any similar type of fixture. The tubular member 5 is visible, as the protection sleeve 6 is only provided under ground to ease the intrusion of the tubular member 5 by preventing the masses in the drilled hole to rest against the tubular member. In the tubular member 5, a central pipe 9 such as an umbilical or supply pipe is provided in order to introduce any necessary conduits such as hydraulic oil conduits to the drilling system, and also to transport crushed masses out of the drilling

55

system.

**[0025]** The forward thrust on the drill head 1 can be realized using separate systems both from out of the drill hole and from inside the bore. Several alternative systems can be used in combination or alone to provide the necessary counter torque and forward thrust. The use of the tubular member 5 allows the drill head 1 to be pulled out of the bore, whereby the tubular member 5 is left in the drilled hole to prevent collapse.

**[0026]** In a further embodiment of the invention, a system to collect ground water before and during the drilling process can be provided. Such a system could be provided at the entrance arrangement 8.

**[0027]** Fig. 2a shows an exemplary embodiment of the drill head 1. The drill head 1 comprises a drill bit 101 with expendable reamers 102. In this exemplary embodiment, three expandable reamers 102 are provided. The reamers 102 are free to move in grooves 103 relative to both the axial and radial direction of the drill head.

**[0028]** When the drill head 1 is pressed against the ground, the reamers 102 are pressed backwards against the grooves 103 and shift radially out at the same time, so that the radial extension of the drill bit 101 is increased. In alternative embodiments, the drill head 1 can be equipped with impact or hammering functionality together with drilling functionality in order to manage severe conditions with stones and varying formations in the ground. The impact functionality can be based both on a medium, such as oil or air, or on pure mechanical means. On the back of the drill bit 101, a crushing cone 104 is provided in order to crush and remove the drilled masses. The crushing cone 104 is equipped with hard bits 105, for example hard metal bits.

**[0029]** Fig. 2b shows a schematic cross section through the drill head 1 and its interaction with the hydraulic motor 2. The hydraulic motor 2 drives the drill bit 101 over a shaft 106, which is connected to the rotor of the hydraulic motor 2. The rotor is hollow and forms a central pipe 108, so that a path to transport crushed masses out of the drill system is formed over the hollow space 107, as indicated by the arrows. The crushing of masses is achieved by rotation of the crushing cone 104 with respect to a stationary conical crushing ring 110. The conical crushing ring 110 comprises wedged slits and radial tracks where particles such as gravel up to a certain size are crushed to smaller particles and flushed into a central rotating pipe 108.

**[0030]** The crushing system is equipped with a flushing system 109 that aids feeding masses into the central pipe 108 as well as dissolving masses around the drill bit, such as clay, soil, or sand. A swivel at the end of the hydraulic motor shaft 106 is connectable to a central pipe 9 that provides suction and separation of the masses from inlet flush media, such as water. The hollow space 107 is equipped with nozzles that flush the masses into the rotating central pipe 108 in the core of the drill head drive axle. The central pipe 108 is in the core of the drive shaft for the drill head 1 and passes through the rotor of the hydraulic motor 2 on the way out of the drilling system. Thus, drilled and crushed masses can pass through the hollow core of the motor.

**[0031]** Fig. 3a shows a schematic representation of an embodiment of a hydraulic motor for a steering system comprising a steering joint according to the invention. The hydraulic motor 2 comprises a housing 201 with a central rotor 202.

**[0032]** The rotor 202 is hollow to allow to pass a central pipe 108 through the motor 2. At the face of the housing 202 there is provided an end nut 203. Seals 204 and end lids 205 are provided to seal the rotor against the hydraulic medium. The hydraulic motor 2 is based on impellers in the form of axially rotating rocker vanes 208 which are provided on a central rotor 202. The rocker vanes 208 are able to swing out from the rotor to a limited radial distance such that when pressurized, they are preferably not in direct contact with the wall of the motor house 201. In a further embodiment, the rocker vanes are able to swing out from the rotor to such a radial distance that they get in contact with the wall of the motor house 201. Three vanes 208 are shown, where the upper vane is in a retracted state, and the lower two vanes are folded out. To enable the vanes 208 to fold out, elastic elements such as springs 214 are provided for each vane 208.

**[0033]** Fig. 3b shows a further schematic representation of the hydraulic motor 2 with a central hollow rotor 202, a housing 201 and an end nut 203. Fig. 3c shows the cut A-A indicated in Fig. 3b. The hydraulic motor 2 comprises a housing 201 with a central rotor 202. The rotor 202 is hollow in order to pass a central pipe 108 through the motor 2. At the face of the housing 202 there is provided an end nut 203 to couple the motor 2 to other components. Seals 204, end lids 205 and O-rings 209 are provided to seal the rotor against the hydraulic medium. Axially rotating rocker vanes 208 are provided on the rotor 202. A guide plate 206 and a port plate 207 is provided to correctly guide the hydraulic medium into and out of the motor.

**[0034]** Fig. 3d shows the cut B-B indicated in Fig. 3b. The motor 2 has an outer housing 201 and a central hollow rotor 202. The rotor 202 carries eight vanes 208 which can swing around an axis that is parallel to the rotation axis of the rotor 202. On its inner surface, the housing 201 has four salient cams 210 which separate the annular space between the housing 201 and the rotor 202 into four separate hydraulic chambers 211. Within each chamber 211, the port plate 207 provides an inlet 212 and an outlet 213 for the hydraulic medium. Inlets 212 and outlets 213 are provided directly adjacent to each salient cam 210, so that in any position of the rotor 202, there is a vane 208 or a salient cam 210 provided between any inlet 212 and neighbouring outlets 213. In order to swing the vanes 208 out of their retracted state, elastic elements such as springs 214 are provided between the rotor 202 and each vane 208.

**[0035]** Whenever a vane 208 passes a salient cam 210 and the inlet 212, the spring 214 moves the vane 208 axially out, so that the pressure of the medium pushes the vane 208 and drives the rotor 202. The number of salient cams 210

is always more than two, and can be as many as necessary due to the wanted torque of the motor.

**[0036]** The number of rocker vanes 208 on the rotor 202 is always higher than the number of salient cams 210 and is limited by practical design limitations such as the diameter of the motor chamber. With respect to rotation of the rotor 202 is the inlet 212 in the bottom at the end of the chamber 211, and the outlet 213 is in front of the chamber 211. The rocker vanes 208 are designed with a circular curved face at the rim and when folded into the rotor 202, they will be co-radial with the outer cylindrical part of the rotor cylinder 202. Thus, the rotor 202 will always form hydraulic chambers 211 between two salient cams. When the rocker vanes 208 are between two salient cams 210, the vanes 208 will swing out towards the inside face of the housing 201 and thus will function as a piston with the inlet 212 on the back of the vane 208 and the outlet on front of the vane 208. The outward swinging of the vanes 208 is limited by the rotor geometry and the vanes 208 will in general not rest against the cylindrical face of the housing 201 when the pressure is active on the vane in the outer rotated position. When one vane 208 is entering the hydraulic chamber over the cam 210, the vane in front is leaving without active pressure from the inlet 212. When the vane 208 hits the salient cam 210 at the outlet, the pressure from the inlet 212 is already active on a new vane 208.

**[0037]** The internal seal system for the hydraulic motor is based on viscous sealing by small slits due to the hydraulic flow of oil. In order to minimize the leakage, the vanes 208 can be equipped with longitudinal tracks 215 at their outermost ends that function as an extra flow resistance for the oil leakage. The inherent benefit with this design is the small size and that the motor does not need a valve system to control the inlet 212 and the outlet 213 hydraulic ports, as this is controlled by the rocker vanes 208 and the separation of each chambers by the salient cams 210. The motor design allows a central hollow shaft, which is a prerequisite for implementing functions such as a central pipe 108 through the central rotor core of the motor. The design allows a high volume efficiency since each hydraulic chamber 211 is always in operation on one rocker vane 208. Therefore, the start-up torque is not reduced during the course of the rotation.

**[0038]** The vanes 208 have a mechanical stop 216, which touches the tip 217 of a recess in the outer surface of the rotor 202 in order to avoid an extensive axial displacement of the vane 208. Therefore, it is avoided that the vane 208 comes in direct contact with the housing 201.

**[0039]** Fig. 3e shows a schematic explosion diagram of the main components of the motor 1, which have been described above. Fig. 3f shows a schematic representation of the guide plate 206, which separates the four inlet ports 212 from the four outlet ports 213 and also shows the central inlet 220. Fig. 3g shows a schematic representation of the port plate 207, which leads the inlet ports 212 and outlet ports 213 into the chambers 211 of the motor 2. Fig. 3h shows a schematic representation of a vane 208, where the mechanical stop 216 is depicted, which is realized as an elongated protrusion at the outer surface of the vane 208. Further, the longitudinal tracks 215 at the outer surface of the vane 208 are seen, which provide an additional flow resistance against oil leakage.

**[0040]** Fig. 3i - 3k show a further embodiment of a hydraulic motor according to the invention. In this embodiment, the outward movement of the vanes 208 is not restricted by a mechanical stop, and thus a contact between the vanes 208 and the housing 201 is possible. However, in order to avoid the vanes being pressed against the housing 201 by the pressure difference between the inlet port 212 and the outlet port 213, the vanes 208 are pressure-compensated by a compensation vent 218. The compensation vent 218 is connected both to the inlet port 212 and to the outlet port 213 during the course of rotation of the rotor 202. The compensation vent 218 thus eliminates the force pressing the vanes 208 outwards against the housing 201 that is caused by the pressure difference between the inlet port 212 and the outlet port 213. It leads from an opening in front of the vane 208 back to a pressure balancing chamber 223 in which a compression spring 220 is provided. The pressure balancing chamber is limited by the radius 219 on the vanes 208 that fits closely with the rotor 222. During the course of rotation, as indicated by the arrow 221, when the front of the vane 208 has passed the salient cam 210, the vent 218 is pressurized by the inlet port 212 in such a way that the pressure is transferred to the pressure balancing chamber 223, so that the vane 208 is pressed out against the housing 201. This force created by the compensation vent 218 aids the force by the spring 220 to rotate the vane 208 outwards.

**[0041]** As soon as the vane 208 has passed the inlet port 213, the pressure compensation vent 218 is exposed to the outlet port 213, so that the pressure balancing chamber 223 is depressurized and the vane 208 is not further pressed against the housing 201.

**[0042]** When the vane 208 passes the outlet port 213, the vane 208 contacts the cam 210 and is forced inwards again. However, the oil inside the pressure balancing chamber 223 is forced backwards through the compensation vent 218 due to the inward movement of the vane 208. This excess oil will build a film between the outer surface of the vanes 208 and the salient cams 210, so that mechanical contact is prevented. Any oil leakage from the inlet port 212 of the next chamber to the outlet port 213 of the previous chamber will be conducted into the compensation vent 218 and thus balances the vanes 208 when passing the cams 210.

**[0043]** Fig. 4a shows a schematic representation of an embodiment of a steering joint 3 according to the invention, which allows direction control of a drilling system such as the one shown in Fig. 1 during drilling. The steering joint 3 is mounted after the hydraulic motor 2 and is hollow to allow to pass a central pipe which can be used, for example, for supply functions or waste removal. The overall functionality of the steering joint is to provide a stepwise controlled steering orientation with predetermined bending angles for each step. The steering joint 3 comprises an upper tubular

301 and a lower tubular 302, which are connected by a universal joint 303 comprising several parts as explained below, which allows the upper tubular 301 to bend with respect to the lower tubular 302. The upper tubular 301 and the lower tubular 302 are coupled to each other in such a way, that individual rotation relative to each other is prevented. This is achieved by means of pins 305 on a pin keeper 309 at the inside of the lower tubular 302, which engage into axially oriented groove tracks 304 on the outside of the universal joint 303, so that the upper tubular 301 and the lower tubular 302 can be tilted, but are rotationally locked to each other. The lower tubular 302 is encased by an end lid housing 310.

**[0044]** Fig. 4b shows a schematic representation of the universal joint 303. It comprises a bell-shaped bearing socket 306 with axial groove tracks 304 on its outer surface, a cylindrical step piston 308, and a mechanical spring 307 inside the step piston 308. At its outer surface, the step piston 308 comprises circumferential slotted wedges or wedged tracks 316.

**[0045]** The steering principle is based on the ends of the bearing socket 306 and the step piston 308 being axially connected by means of multiple radial cams 311 on the face end of the bearing socket 306 engaging into differently sized radial grooves 312 on the face end of the step piston 308. The radial grooves 312 are of different depth and are disposed in inclined planes on the face end of the step piston 308. In contrast to the radial grooves 312, the radial cams 311 are of equal size.

**[0046]** For each desired steering angle, the step piston 308 is equipped with three or more grooves 312, which are distributed at the face end of the step piston 308 in order to form a stable end-to-end connection with the radial cams 311 at the face end of the bearing socket 306. The grooves can be distributed equally at the face end of the step piston 308. By rotating the step piston 308 and aligning the grooves 312 at the desired tilting angle with the cams 311, the grooves 312 on the step piston 308 match with the radial cams 311 on the bearing socket 306 and force the joint assembly to be directed in the wanted orientation. In a typical design, the step piston 308 is designed with three inclination angles for four grooves 312 distributed around 360 degrees, i.e. 90 degrees for each set of different grooves 312. This results in a total of twelve steps with a rotational stepwise orientation of 30 degrees between each step where 4 of the steps are in the straight forward direction, thus nine different orientations are achievable. The arrangement of grooves 312 in specific angles can, for example, be zero, four and eight degrees. At zero degree is the steering assembly straight without bending, and at 4 and 8 degrees is the upper tubular 301 as well as the bearing socket 306 angled in 4 or 8 degrees in one of the four directions of the radial cams 311.

**[0047]** Fig. 4c shows a schematic and half-cut view of the steering joint 3, where part of the step piston 308 is removed for clarity. It shows the pins 305 which are provided at the inner surface of the lower tubular 302 and engage into the radial groove tracks 304 of the bearing socket 306 for a positive radial connection between the lower tubular 301 and the upper tubular 302. In order to set the steering angle, it is necessary to rotate the step piston 308 in a stepwise fashion. In one embodiment, the stepwise rotation is made possible by wedged tracks 316 at the outside of the step piston 308. The wedged tracks 316 are engaged by counter holding pins 313 fixed to a cylindrical pin keeper 309, which is connected to the lower tubular body 302.

**[0048]** The stepwise orientation is achieved by an axial movement of the step piston 308 in a way that forces the piston 308 to rotate half of the rotational step in one directional movement one way. A reciprocal movement back and forth of the piston 308 will rotate the piston one full step. This mechanism is similar to the mechanism responsible for protruding and retracting the tip in some ballpoint pens. The force for the axial forward movement of the step piston 308 is created by hydraulic pressure, and the return force is provided by a mechanical spring 307, which is arranged inside the step piston 308. The grooves 312 at the face end of the step piston 308 will engage with the cams 311 at the bearing socket 306 and thus force the bearing socket 306 and the upper tubular 301 in the desired direction in fixed inclined angles for each of the orientation of the radial cams 311.

**[0049]** Fig. 4d shows a schematic view of the step piston 308. At the face end of the step piston 308, differently sized radial grooves, namely shallow grooves 312', regular grooves 312'', and deep grooves 312''' are provided. In this specific embodiment, each groove 312 is displaced at an angle of 30° from the neighboring groove 312. Fig. 4e shows a schematic view of the bell-shaped bearing socket 306. It comprises an annular flange 314 with circumferential axial grooves 304 and four axial cams 311, placed at an angle of 90 degrees. Each axial cam 311 has the same axial extension.

**[0050]** In an additional embodiment of the steering joint, the rotation of the step piston is performed by an electric motor. This motor can be a stepper motor or a hydraulic or electrical motor-gear system that provides the wanted rotation in fixed steps. The benefit of a pure hydraulic system is the robustness and versatility of the construction. This aspect is important in relation to necessary control or actuation electronics in the drill head. As a further advantage, when the hydraulic pressure is removed, the steering assembly will be free to bend in any direction without any counter force. This is very important if the drill head assembly has to be pulled back through the drilled hole.

**[0051]** The use of a one-way operated hydraulic piston with a spring return that both provides the rotation and orientation in the same movement, and provides the desired tilting angle and three-dimensional orientation can be achieved by a single hydraulic control line.

**[0052]** The actual steering orientation for the joint is controlled by the rotational position of the piston 308. The rotational position can be measured by an electrical circuit with feedback sensor that measures the absolute position of the piston

rotation. The orientation of the steering system in relation to the global direction can be determined by a position measurement system that detects the orientation of the upper part tubular housing of the steering joint and thus relates the orientation of the lower part of the steering joint relative to this measured orientation in a stepwise way.

**[0053]** Fig. 4f show a further embodiment of the steering joint 3 in a schematic explosion view. Fig. 4g and Fig. 4h show this embodiment in a schematic assembled configuration, where parts of the tubulars have been cut away for clarity. Fig. 4i - 4k show further views of this embodiment. In this embodiment, the steering joint 3 comprises an upper tubular 301 and a lower tubular 302 which are connected by a universal joint 303, which allows the upper tubular to bend with respect to the lower tubular. The upper tubular 301 and the lower tubular 302 are coupled to each other in such a way, that individual rotation relative to each other is prevented. This is achieved by means of pins 305 at the inside of the lower tubular 302, which engage into axially oriented groove tracks 304 on the outside of the universal joint 303, so that the upper tubular 301 and the lower tubular 302 can be tilted, but are rotationally locked to each other. The lower tubular 302 is encased by an end lid housing 310. In order to set the steering angle, it is necessary to rotate the step piston 308 in a stepwise fashion. In this embodiment, the stepwise rotation of the step piston 308 is achieved by a circumferential hydraulic piston 317 operating rotationally in an annular rotator housing 326, that rotates the step piston 308 the required step. A carrier 315 that engages with wedged tracks 316 on the shaft of the step piston 308 provides the mechanical connection between the step piston 308 and the hydraulic piston 317 to perform the rotation of the step piston 308.

**[0054]** This movement is operating similar to a ratchet and an oscillating movement of the hydraulic piston 317 will provide the rotational movement of the step piston 308. The oil flow design for the circumferential hydraulic piston 317 and the piston 308 is made in such a way that the inflow of the hydraulic medium into the pistons through the inlet hole 318 will first actuate the circumferential piston 317 until it is at the end position, where any additional movement is prevented by the rotator housing 326.

**[0055]** In Fig. 4g, the circumferential piston 317 is depicted in its initial state, and in Fig. 4h, the circumferential piston 317 is rotated to its end position. When the circumferential piston 317 is at its end position, the inlet hole 318 from the side of the cylinder bushing 319 opens due to the movement of the circumferential piston 317. This stops the rotating, ratchet-type movement and allows the oil to flow freely into the main step piston 308 chamber.

**[0056]** If the selected position of the main step piston has been obtained, a continuous adding of a hydraulic medium forces the main step piston 308 to move axially towards the bearing socket 306, thus providing the steering angle adjustment. If the selected position of the main step piston has not been reached, a bleed-off of the hydraulic medium will return the circumferential hydraulic piston 317 by a return mechanism. The displacement volume in the rotator housing 326, where the circumferential hydraulic piston 317 operates, can be hydraulically compensated to the step piston chamber. This compensation provides an axial movement of the step piston 308 that is kept below the needed axial movement for engaging with the bearing socket 306.

**[0057]** The circumferential hydraulic piston 317 is equipped with a return spring 320 that provides the return rotation and allows for the next step to be engaged after pressure has been provided to the hydraulic medium again. The ratchet-type oscillating motion is repeated until the desired position of the main step piston has been reached. Then, by continuing the adding of the hydraulic medium, the movement of the main step piston 308 for the steering angle adjustment is provided. The return movement of the step piston 308 is activated by a several axial springs 321 that push against an axial bearing carrier 322 that is connected to the step piston 308 by a groove with balls 323. During the return stroke the oil flow is directed through a return gate 324 with a check valve 325 in the rotator housing 326 to secure the possibility of returning the hydraulic medium when the circumferential hydraulic piston 317 is blocking the inlet hole 318.

**[0058]** Fig. 4l shows a schematic side view of the step piston 308 according to the embodiment of Fig. 4f. The step piston 308 comprises a shaft with axial grooves 316, in which the carrier 315 engages to rotate the step piston 308.

**[0059]** At its face end, the step piston 308 is provided with shallow grooves 312', regular grooves 312'', and deep grooves 312''', defining a steering inclination of 0°, 4°, and 8°, respectively, and placed 30° apart along the radius of the face end of the step piston 308. Fig. 4m shows a schematic view of the rotator housing 326, which is provided with a recess to hold the hydraulic piston 317 at its outer circumference. The recess covers only a small sector of the outer circumference of the housing 326, such as 20° - 40°, and enables a movement of the hydraulic piston 317 along the circumference of the rotator housing 326. In order to introduce hydraulic medium, an inlet is provided in the side wall of the recess.

**[0060]** Fig. 5a shows a schematic view of a proposed counter hold system 4 which allows to hold the torque of a drilling system such as the one shown in Fig. 1 during drilling. The counter hold system 4 is connectable on one end to the steering joint 3, and on the other end to a tubular member 5 which shall be pulled forward into a drilled hole. The counter hold system 4 comprises a hollow flexible bellows 401 which is clamped between two end nuts 402. The flexible bellows 401 is made of rubberlike material that allows both radial and axial expansion when an internal pressure is applied by a pressurized medium. The primary function of the counter hold system 4 is to expand radially out and thus fix parts of the drill string to the surrounding ground in order to create sufficient counter hold to the ground for both the rotation and the axial movement while drilling. The axial movement can be provided by the bellows itself, or by an axial

force providing device. The secondary function is to create a forward thrust force by allowing the flexible bellows 401 to expand axially.

**[0061]** Fig. 5b shows a schematic explosion view of an exemplary embodiment of the counter hold system 4. The counter hold system 4 comprises two end nuts 402, and a flexible bellows 401 between them. Inside the flexible bellows 401 there is a cylinder body 403 with axial grooves 406 at its outer surface. The cylinder body 403 houses an axially displaceable piston 404 and is inserted into a cylinder housing 405. The piston 404 is axially movable within the cylinder body 403, and is on one end by means of a seal ring 410 connected to the cylinder housing 405. The piston 404 is hollow to allow to pass a central pipe through its center.

**[0062]** The flexible bellows 401 is restrained on one end to the cylinder body 403, and on the other end to the cylinder housing 405, hence the axial extension of the bellows is limited by the stroke of the piston 404 inside the cylinder body 403. Any rotation between the cylinder body 403 and the piston 404 is prevented by radial pins 407 in the cylinder housing 405 which extend and are guided in axial grooves 406 or tracks of the cylinder body 403. The cylinder housing 405 further comprises medium inlets 408 to insert pressurized medium into the flexible bellows 401 over medium outlets 409 at the outer surface of the cylinder housing 405.

**[0063]** Fig. 5c shows the counter hold system 4 in retracted state inside a drilled hole. In the start position, the cylinder will stay in the shortest axial position and the bellows 401 is deflated. The flexible bellows 401 is not under pressure, and the piston 404 is driven completely into the cylinder body 403, so that the cylinder housing 405 covers the cylinder body almost completely. Fig. 5d shows the situation when the flexible bellows 401 is pressurized by leading a pressurized medium through the medium inlets 408 into the flexible bellows 401. The flexible bellows 401 extend first radially, until the radial extension is stopped when the flexible bellows gets in contact with the walls of the drilled hole. The radial expansion is then stopped due to the counter force from the hole walls, so that the bellows will press against the hole walls and will produce sufficient counter hold against the rotation of a front drill bit. By applying further pressure to the inside of the bellows, the bellows 401 will expand axially and push the cylinder body 403 forward. The piston 404, which is connected to the cylinder housing 405, will remain in its position, but the cylinder body 403 will move axially until the movement is stopped when the radial pins 407 reach the end of the axial grooves 406. This axial force from the bellows 401 is sufficient to push a drill bit forward or into the ground. The force for expanding the bellows 401 is created by an external arrangement upwards in the drill assembly and can be provided by different means such as an expanding hydraulic or pneumatic piston, or an axial linear electrical actuator or a common axial force providing drilling system.

**[0064]** Fig. 5e shows the situation when the flexible bellows 401 is evacuated again. The bellows 401 retracts and pulls the cylinder housing 405 along the axial grooves 406 forward, so that the piston 404 is shifted forward together with the cylinder housing 405 and any tube or drill string that is connected to the end nut 402.

**[0065]** The negative stroke of the counter hold system can be provided by applying a negative pressure on the expanding fluid medium inside the bellows by an internal or external force providing system.

**[0066]** Fig. 6a shows a schematic view of a first embodiment of a proposed protection sleeve system 5, which can be applied to the tubular member 5 of a drilling system such as the one shown in Fig. 1. Also depicted is a drill string 501 which guides a drill head into the ground and pulls a tubular member 502 into the drilled hole. In this embodiment, a sleeve 504 is provided, which comprises a flexible braiding that allows some radial expansion, and on which a leakage safe membrane layer of rubber or plastic or a similar material is applied. The advantage of the braiding is that it allows for a higher radial expansion. The sleeve 504 is stored in an annular sleeve magazine 503 which is attached at the face end of the tubular member 502. The storage of the sleeve 504 in front end of the tubular member 502 allows it to be released or fed from the magazine 503 by the pull force which is generated by intrusion of the tubular member 502 into the ground. The sleeve is on one end attachable to the outlet flange 510 of the entrance arrangement 505 at the borehole and will cover the whole length of the tubular member 502. The sleeve 504 is leakage safe fixed to the outer surface of the lower face end of the tubular member 502. At the entrance arrangement 505, the end of the tubular member 502 is sealed with a seal ring 507. Thus, a free and sealed space between the tubular member 502 and the sleeve 504 is formed, which builds a closed annulus chamber 508 from the end of the tubular member 502 to the entrance seal 507 on the entrance arrangement 505. By applying a pressurized fluid such as oil or air through the inlet port 509 into the annulus chamber 508, the annulus chamber 508 will be pressurized and thus radially expand. The sleeve 504 will push against the surrounding ground. Thus, a pressurized pipe in pipe system is created, that effectively reduces the friction of the tubular member 502 against the surrounding ground, so that the entering of the tubular member 502 into the ground is eased. The detail in Fig. 6a shows how the sleeve 504 is stored in the sleeve magazine 503, and how the annulus chamber 508 is formed between the expanded sleeve 504 and the tubular member 502. Also shown is the drill string 501.

**[0067]** Fig. 6b shows a schematic cross-section view of the entrance arrangement 505.

**[0068]** The entrance arrangement 505 comprises an outlet flange 510 which is sealed around the tubular member 502 over seal rings 511. The flange 510 is connected to the hole in the wall 506 over a casing 512 which is partly introduced into the hole. A mechanical stop element 513 fastens the sleeve 504 at the flange 510, so that a tight annular chamber 508 is achieved. A thin conduit 514 between the annular chamber 508 and the port 509 enables to introduce



a pressurized medium into the annular chamber 508.

5 **[0069] Fig. 6c** shows a second embodiment of the protection sleeve system 5. In this embodiment, two different layers are combined to reach the desired properties. An outer structural part 515, preferably in the form of a structural braiding to achieve structural strength, is combined with an internal leakage safe member in form of a thin elastic hose 518 that rests against the inside of the structural part 515 when pressurized. In one possible arrangement, the structural part 515 and the elastic hose 518 are stored separately. An annular storage for the structural part or braiding 516 is provided at the front of the tubular member 502, and a separate annular hose storage 519 is provided on the outer surface of the tubular member 502. Both the structural part 515 and the elastic hose 518 can be fixed to the entrance arrangement 505, and thus cover the whole length of the tubular member 502. A divider 517 between the structural part 515 and the elastic hose 518 is attached to the outer surface of the tubular member 502 between the structural part storage 516 and the hose storage 519. This divider 517 separates the structural part 515 from the elastic hose 518 and prevents the elastic hose 518 to be axially displaced into and over the structural part storage 516. By applying a pressurized medium through the inlet port 509, the annular chamber 508 between the tubular member 502 and the elastic hose 518 will be pressurized and the elastic hose 518 will radially expand and force the structural part 515 to rest against the inside of the drilled hole and thus prevent the collapse of the drilled hole.

10 **[0070] Fig. 6d** shows a third embodiment of the protection sleeve system 5. In this embodiment, the sleeve 504 is not stored at the face end of the tubular member 502 underground, but outside of the drilled hole in a separate sleeve magazine 503 which is attached to the outside end of the tubular member 502 after the entrance arrangement 505. One end of the sleeve 504 is attached to the entrance arrangement 505, and the other end of the sleeve 504 is attached to the sleeve magazine 503.

20 **[0071]** At the end of the tubular member 502, a roller casing 522 is attached which holds a roller element 521 that turns the sleeve 504 around inside the annulus between itself and the tubular member 502 and further along the full length of the tubular member and out through the entrance arrangement 505. This embodiment provides a double sleeve system. The feeding of the sleeve during the intrusion of the pipe is done from outside in the annulus between the pipe and the outermost part of the sleeve in a separate sleeve magazine 503. The annular chamber 508 between the double laid sleeve 504 is pressurized by a fluid medium introduced through a medium inlet port 509 and thus radially expands the sleeve to rest against the ground. This pressurized sleeve conduit system creates a double-layered pipe in pipe system that effectively reduces the friction against the ground for entering the tubular member and the drill string into the ground.

25 **[0072] Fig. 7a** shows a magnetic propulsion system 6 which allows to create forward thrust on a drill head assembly of a drilling arrangement such as the one shown in Fig. 1. The forward thrust is created by means of a magnetic source providing arrangement, particularly outer annular plugs 601 with handles 602. In alternative embodiments, other magnetic source providing arrangements can be provided, such as partially annular or rectangular magnet holders. The outer plugs 601 are movably arranged outside of the entrance arrangement 603 and encircle the tubular member 604. They can be brought in a position to create a magnetic force onto corresponding inner annular plugs 605 that are arranged inside the tubular member 604 and are movably arranged around an inner pipe 606, which might comprise supply lines to a drill head arrangement or other drill components.

30 **[0073]** The outer plugs 601 comprise a plug sleeve 607, which is rotatable around the outer circumference of the tubular member 604 and is axially shiftable by the handle 601. The plug sleeve 607 carries several magnets 608. The tubular member 604 forms together with the inner pipe 606 a hollow annular chamber 609 which is filled with a medium such as hydraulic oil. The inner annular plugs 605 are axially displaceable arranged around the inner pipe 606 and form a ring-shaped piston within the annular chamber 609. On the other end of the tubular member 604 and the inner pipe 606, these pipes are connected to the drill head arrangement or other drill system components, which enclose the annular chamber 609 tightly.

35 **[0074]** The inner annular plug 605 comprises seal rings 610 both against the tubular member 604 and against the inner pipe 606. Thus, the inside of the annular chamber 609 constitutes a closed hydraulic cylinder. The inner plugs 605 are further connected by an axial thrust coupling 612 to increase the transferrable thrust. In a similar way, the outer plugs 601 are connected at their sleeves or casing 613. By pressurizing the annular chamber 609, an axial force can thus be exerted on the drill head. To put pressure on the chamber 609, the inner plug 605 can be axially displaced by the outer plug 601. The outer plug 601 is coupled to the inner plug 605 by means of a magnetic circuit.

40 **[0075]** The magnetic circuit comprises a magnet 608 such as an electromagnet or a permanent magnet, which is provided on the outer plug 601, and is embedded in a magnetically conducting material 611 such as ferromagnetic iron forming two distinct poles. On the inner plug 605, a similar magnetically conducting material is provided with correspondingly shaped poles, such that the magnetic circuit can be closed when the magnetic poles of the outer plug 601 are brought into alignment with the magnetic poles of the inner plug 605. The magnetic force is created by permanent or electrical magnets 608 arranged in a magnetically conducting material 611 in a way that allows the magnetic flux to be rotated, for instance pulled away by a plug sleeve 607 which can be manually or automatically operated by a handle 602. By rotating the handle 602, the poles of the magnetic material on the inner plug 605 and the outer plug 601 can be

## EP 3 228 809 B1

brought into, or out of, alignment. For this, the plug sleeve 607 to open or close the magnetic circuit between the inner plug 605 and the outer plug 601 can be electrically or manually operated in order to turn the magnetic force onto the inner plug 605 on and off. The moving of the magnets 608 thus directs or removes the coupling force between the inner plugs 605 and the outer plugs 601.

5 **[0076]** Fig. 7b shows a schematical view of the magnetic system from the outside. Typically, the shape of the magnets 608 is circular with a magnetic field direction across the length axis as indicated by the arrows in the figure. In alternative embodiments, other mechanical arrangements can be chosen to displace the magnets 608 outside of the magnetic circuit of the plugs.

10	<b>List of numerals</b>					
	1	Drill head	223	Pressure compensation chamber	408	Medium inlet
	2	Hydraulic motor			409	Medium outlet
	3	Steering joint			410	Seal ring
	4	counter hold system				
15			301	Upper tubular	501	Drill string
	5	Tubular member	302	Lower tubular	502	Tubular member
	6	Protection sleeve	303	Universal joint	503	Sleeve magazine
	7	Wall	304	groove tracks	504	Sleeve
20	8	Entrance arrangement	305	pins	505	Entrance arrangement
			306	bearing socket		
	9	Central pipe	307	mechanical spring	506	Wall
	10	Hole	308	step piston	507	Seal ring
			309	pin keeper	508	Annular chamber
25	101	Drill bit	310	end lid housing	509	Inlet port
	102	Reamer	311	radial cam	510	Outlet flange
	103	Groove	312	radial groove	511	Seal ring
	104	Crushing cone	312'	shallow radial groove	512	Casing
30	105	Hard bits			513	Stop element
	106	Shaft	312"	regular radial	514	Conduit
	107	Hollow space		groove	515	Structural part
	108	Central pipe	312'''	deep radial groove	516	Structural part storage
	109	Flushing system				
35	110	Crushing ring	313	Counter holding pin	517	Divider
					518	Elastic hose
	201	Motor housing	314	Annular flange	519	Storage for hose
	202	Rotor	315	Carrier	521	Roller element
40	203	End nut	316	Wedged tracks	522	Roller casing
	204	Seal	317	Circumferential piston		
	205	End lid			601	Outer annular
	206	Guide plate	318	Inlet hole		plug
	207	Port plate	319	Cylinder bushing	602	Handle
45	208	Vane	320	Return spring	603	Entrance arrangement
	209	O-ring	321	Axial spring		
	210	Salient cam	322	Axial bearing carrier	604	Tubular member
	211	Chamber			605	Inner plug
50	212	Inlet	323	Groove with balls	606	Inner pipe
	213	Outlet	324	Return gate	607	Sleeve
	214	Spring	325	Check valve	608	Magnet
	215	Track	326	Rotator housing	609	Annular chamber
	216	Mechanical stop			610	Seal ring
55	217	Tip	401	Flexible bellows	611	Magnetically
	218	Vent	402	End nut		conducting
	219	Vane radius	403	Cylinder body		material

(continued)

220	Central inlet	404	Piston	612	Axial thrust
221	Direction of rotation	405	Cylinder housing		coupling
5		406	Axial groove	613	Casing
222	Rotor	407	Pin		

## Claims

- 10
1. Steering joint (3) for a steerable drilling system, comprising an upper tubular (301) and a lower tubular (302) connected by a universal joint (303) which allows the upper tubular (301) to bend with respect to the lower tubular (302), wherein the universal joint (303) comprises
- 15
- a. a joint bearing socket (306) with a hollow core, comprising axially protruding cams (311) with identical extension on a substantially ring-shaped face end,
- b. a cylindrical and rotatable step piston (308) with a hollow core and radial grooves (312) on a substantially ring-shaped face end,
- 20
- c. wherein the cams (311) and the grooves (312) are arranged in such a way to provide a positive force-fitting connection of the bearing socket (306) with the step piston (308), and
- d. wherein the grooves (312) are of different depth and their bases define inclined planes with respect to the plane of the face end of the step piston (308), so that the upper tubular (301) and the lower tubular (302) can be tilted with respect to each other at predefined steering angles.
- 25
2. Steering joint according to claim 1, **characterized in that** on the face end of the step piston (308), preferably at least three grooves (312', 312", 312''') are arranged in specific inclined planes of different angles at each of preferably four predefined rotational steps of the step piston (308), so that four rotational steps result in at least twelve inclination steps of the axis of the lower tubular (302) with respect to the axis of the upper tubular (301).
- 30
3. Steering joint according to claim 2, **characterized in that** four steering angles of 0°, 90°, 180°, and 270° and three grooves arranged in inclined planes of 0°, 4°, and 8° with respect to the plane of the face end of the step piston (308) are predefined, wherein each groove (312', 312", 312''') is placed at a center angle of 30° from the neighboring grooves.
- 35
4. Steering joint according to any of claims 1 to 3, **characterized in that** it comprises a tubular pin keeper which is coupled to axial groove tracks (304) on the outer surface of the bearing socket (306), so that the upper tubular (301) and the lower tubular (302) are rotationally locked to each other.
- 40
5. Steering joint according to any of claims 1 to 4, **characterized in that** the step piston (308) is rotatable by a hydraulic or electric motor, such as, for example, a stepper motor.
- 45
6. Steering joint according to any of claims 1 to 5, **characterized in that** the step piston (308) is axially movable by a force, such as a hydraulic force, and is equipped with wedged tracks (316) on its outer circumference, wherein the wedged tracks (316) are engaged by counter holding pins (313) fixed or connected to the lower tubular (302), so that an axial movement of the step piston (308) causes a rotation of the step piston (308) with respect to the lower tubular (302), and a return force is provided by a mechanical spring (307) arranged between the step piston (308) and an inner face of the lower tubular (302).
- 50
7. Steering joint according to any of claims 1 to 5, **characterized in that** the step piston (308) is coupled to at least one circumferential and ring-section-shaped hydraulic piston (317) which is held in an annular rotator housing (326) by means of a carrier (315) in such a way, that it can be moved in a stepwise fashion in the rotator housing (326) by means of applying a hydraulic medium, and a stepwise rotation of the hydraulic piston (317) results in a stepwise rotation of the step piston (308).
- 55
8. Steering joint according to claim 7, **characterized in that** at least one carrier (315) engages with axial oriented wedged tracks (316) on the outer surface of the step piston (308) in order to rotationally couple the step piston (308) to the hydraulic piston (317).

9. Steering joint according to claim 7 or 8, **characterized in that** the hydraulic piston (317) covers a ring section of typically 20° to 40°, preferably 30° of the circumference of the step piston (308).
- 5 10. Steering joint according to any of claims 7 to 9, **characterized in that** the hydraulic piston (317) is equipped with an elastic return element, such as a return spring (320) to pull the hydraulic piston (317) back after each rotation step, so that a ratchet-type oscillation of the hydraulic piston (317) with respect to the rotator housing (326) is achieved.
- 10 11. Steering joint according to any of claims 7 to 10, **characterized in that** at least one elastic element, such as an axial spring (321) is provided on the outer surface of the step piston (308) and is pushing against an axial bearing carrier (322) in order to exert a return force on the step piston (308).
12. Steering joint according to any of claims 1 to 11, **characterized in that** the universal joint (303) is released to freely bend in any direction when there is no pressure force on the step piston (308) in order to pull back the steering joint after operation.
- 15 13. Steering joint according to any of claims 1 to 12, **characterized in that** the rotational position of the step piston (308) and/or the steering orientation of the lower tubular (302) with respect to the upper tubular (301) is measured by an electric or magnetic sensor.
- 20 14. Steerable drilling system, comprising a steering joint (3) according to any of the preceding claims.
15. Steerable drilling system according to claim 14, further comprising a drill head (1), a hydraulic motor (2), a counter hold system (4), a tubular member (5), a protection sleeve (6) and/or a magnetic propulsion system.

25

#### Patentansprüche

- 30 1. Lenkungsgelenk (3) für ein lenkbares Bohrsystem, umfassend eine obere Röhre (301) und eine untere Röhre (302), die durch ein Kreuzgelenk (303) verbunden sind, das es der oberen Röhre (301) ermöglicht, sich in Bezug auf die untere Röhre (302) zu biegen, wobei das Kreuzgelenk (303) Folgendes umfasst:
- 35 a. eine Gelenklageraufnahme (306) mit einem hohlen Kern, umfassend axial vorstehende Nocken (311) mit identischen Verlängerungen auf einem im Wesentlichen ringförmigen Stirnende,  
 b. einen zylindrischen und drehbaren Stufenkolben (308) mit einem hohlen Kern und radialen Nuten (312) auf einem im Wesentlichen ringförmigen Stirnende,  
 c. wobei die Nocken (311) und die Nuten (312) in einer derartigen Weise angeordnet sind, um eine positive kraftschlüssige Verbindung der Lageraufnahme (306) mit dem Stufenkolben (308) bereitzustellen, und  
 d. wobei die Nuten (312) von unterschiedlicher Tiefe sind und ihre Böden in Bezug auf die Ebene des Stirnendes des Stufenkolbens (308) geneigte Ebenen definieren, so dass die obere Röhre (301) und die untere Röhre (302) in Bezug aufeinander in vordefinierten Lenkwinkeln gekippt werden können.
- 40 2. Lenkungsgelenk nach Anspruch 1, **dadurch gekennzeichnet, dass** auf dem Stirnende des Stufenkolbens (308) vorzugsweise mindestens drei Nuten (312', 312'', 312''') in spezifisch geneigten Ebenen von unterschiedlichen Winkeln an jeder von vorzugsweise vier vordefinierten Drehstufen des Stufenkolbens (308) angeordnet sind, so dass vier Drehstufen zu mindestens zwölf Neigungsstufen der Achse der unteren Röhre (302) in Bezug auf die Achse der oberen Röhre (301) führen.
- 45 3. Lenkungsgelenk nach Anspruch 2, **dadurch gekennzeichnet, dass** vier Lenkwinkel von 0°, 90°, 180° und 270° und drei Nuten, die in geneigten Ebenen von 0°, 4° und 8° in Bezug auf die Ebene des Stirnendes des Stufenkolbens (308) angeordnet sind, vordefiniert sind, wobei jede Nut (312', 312'', 312''') in einem Zentriwinkel von 30° von den benachbarten Nuten platziert ist.
- 50 4. Lenkungsgelenk nach einem der Ansprüche 1 bis 3, **dadurch gekennzeichnet, dass** es einen rohrförmigen Stifthalter umfasst, der mit axialen Nutbahnen (304) auf der äußeren Fläche der Lageraufnahme (306) gekoppelt ist, so dass die obere Röhre (301) und die untere Röhre (302) zueinander dreh-schlüssig sind.
- 55 5. Lenkungsgelenk nach einem der Ansprüche 1 bis 4, **dadurch gekennzeichnet, dass** der Stufenkolben (308) durch einen hydraulischen oder elektrischen Motor drehbar ist, wie etwa zum Beispiel einen Schrittmotor.

## EP 3 228 809 B1

- 5 6. Lenkungsgelenk nach einem der Ansprüche 1 bis 5, **dadurch gekennzeichnet, dass** der Stufenkolben (308) durch eine Kraft, wie etwa eine hydraulische Kraft, axial bewegbar ist und mit verkeilten Bahnen (316) auf seinem äußeren Umfang ausgestattet ist, wobei die verkeilten Bahnen (316) mit Gegenhaltstiften (313) in Eingriff kommen, die an der unteren Röhre (302) befestigt oder damit verbunden sind, so dass eine axiale Bewegung des Stufenkolbens (308) eine Drehung des Stufenkolbens (308) in Bezug auf die untere Röhre (302) verursacht und eine Rückstellkraft durch eine mechanische Feder (307) bereitgestellt ist, die zwischen dem Stufenkolben (308) und einer inneren Fläche der unteren Röhre (302) angeordnet ist.
- 10 7. Lenkungsgelenk nach einem der Ansprüche 1 bis 5, **dadurch gekennzeichnet, dass** der Stufenkolben (308) mit mindestens einem umlaufenden und ringquerschnittsförmigen hydraulischen Kolben (317) gekoppelt ist, der in einem ringförmigen Rotatorgehäuse (326) mittels eines Trägers (315) in einer derartigen Weise gehalten ist, dass er stufenweise in dem Rotatorgehäuse (326) mittels Anwenden eines hydraulischen Mediums bewegt werden kann und eine stufenweise Drehung des hydraulischen Kolbens (317) zu einer stufenweisen Drehung des Stufenkolbens (308) führt.
- 15 8. Lenkungsgelenk nach Anspruch 7, **dadurch gekennzeichnet, dass** mindestens ein Träger (315) mit axial ausgerichteten verkeilten Bahnen (316) auf der äußeren Fläche des Stufenkolbens (308) in Eingriff kommt, um den Stufenkolben (308) mit dem hydraulischen Kolben (317) drehbar zu koppeln.
- 20 9. Lenkungsgelenk nach Anspruch 7 oder 8, **dadurch gekennzeichnet, dass** der hydraulische Kolben (317) einen Ringquerschnitt von typischerweise 20° bis 40°, vorzugsweise 30° des Umfangs des Stufenkolbens (308) abdeckt.
- 25 10. Lenkungsgelenk nach einem der Ansprüche 7 bis 9, **dadurch gekennzeichnet, dass** der hydraulische Kolben (317) mit einem elastischen Rückstellelement, wie etwa einer Rückstellfeder (320), ausgestattet ist, um den hydraulischen Kolben (317) nach jeder Drehstufe zurückzuziehen, so dass eine ratschenartige Oszillation des hydraulischen Kolbens (317) in Bezug auf das Rotatorgehäuse (326) erzielt wird.
- 30 11. Lenkungsgelenk nach einem der Ansprüche 7 bis 10, **dadurch gekennzeichnet, dass** mindestens ein elastisches Element, wie etwa eine Axialfeder (321), auf der äußeren Fläche des Stufenkolbens (308) bereitgestellt ist und gegen einen axialen Lagerträger (322) drückt, um eine Rückstellkraft auf den Stufenkolben (308) auszuüben.
- 35 12. Lenkungsgelenk nach einem der Ansprüche 1 bis 11, **dadurch gekennzeichnet, dass** das Kreuzgelenk (303) freigegeben wird, um sich in eine beliebige Richtung zu biegen, wenn es keine Druckkraft auf den Stufenkolben (308) gibt, um das Lenkungsgelenk nach einer Betätigung zurückzuziehen.
- 40 13. Lenkungsgelenk nach einem der Ansprüche 1 bis 12, **dadurch gekennzeichnet, dass** die Drehposition des Stufenkolbens (308) und/oder die Lenkausrichtung der unteren Röhre (302) in Bezug auf die obere Röhre (301) durch einen elektrischen oder magnetischen Sensor gemessen wird.
- 45 14. Lenkbares Bohrsystem, umfassend ein Lenkungsgelenk (3) nach einem der vorhergehenden Ansprüche.
15. Lenkbares Bohrsystem nach Anspruch 14, ferner umfassend einen Bohrkopf (1), einen hydraulischen Motor (2), ein Gegenhaltsystem (4), ein rohrförmiges Element (5), eine Schutzhülse (6) und/oder ein magnetisches Antriebssystem.

### Revendications

- 50 1. Joint de direction (3) pour un système de forage orientable, comprenant une tubulure supérieure (301) et une tubulure inférieure (302) reliée par un joint universel (303) permettant à la tubulure supérieure (301) de fléchir par rapport à la tubulure inférieure (302), dans lequel le joint universel (303) comprend :
- 55 a. un logement de palier à joint (306) avec un noyau creux, comprenant des cames faisant saillie axialement (311) avec une extension identique sur une extrémité frontale substantiellement annulaire,
- b. un piston différentiel (308) cylindrique et rotatif, avec un noyau creux et des rainures radiales (312) sur une extrémité frontale substantiellement annulaire,
- c. dans lequel les cames (311) et les rainures (312) sont disposées de manière à fournir une connexion à force

positive du logement de palier (306) avec le piston différentiel (308), et  
 d. dans lequel les rainures (312) présentent des profondeurs différentes et leurs bases définissant des plans  
 inclinés par rapport au plan de l'extrémité frontale du piston différentiel (308), de telle façon que la tubulure  
 supérieure (301) et la tubulure inférieure (302) peuvent être inclinées l'une par rapport à l'autre selon des angles  
 de direction prédéfinis,

5

2. Joint de direction selon la revendication 1, **caractérisé en ce que** sur l'extrémité frontale de piston différentiel (308)  
 sont disposées de préférence au moins trois rainures (312', 312'', 312''') dans des plans inclinés spécifiques de  
 différents angles au niveau de chacun parmi de préférence quatre étapes de rotation prédéfinies du piston différentiel  
 (308), de telle façon que quatre étapes de rotation résultent dans au moins douze étapes d'inclinaison de l'axe du  
 tubulure inférieure (302) par rapport à l'axe du tubulure supérieure (301).

10

3. Joint de direction selon la revendication 2, **caractérisé en ce que** quatre angles de direction de 0°, 90°, 180° et  
 270° et trois rainures disposées dans des plans inclinés de 0°, 4° et 8° par rapport au plan de l'extrémité frontale  
 du piston différentiel (308) sont prédéfinis, chaque rainure (312', 312'', 312''') étant placée selon un angle central  
 de 30° par rapport aux rainures voisines.

15

4. Joint de direction selon l'une quelconque des revendications 1 à 3, **caractérisé en ce qu'il** comprend un porte-  
 broche tubulaire accouplé à des pistes de rainures axiales (304) sur la surface extérieure du logement de palier  
 (306), de telle façon que la tubulure supérieure (301) et la tubulure inférieure (302) sont bloquées en rotation l'une  
 par rapport à l'autre.

20

5. Joint de direction selon l'une quelconque des revendications 1 à 4, **caractérisé en ce que** le piston différentiel (308)  
 est mis en rotation par un moteur hydraulique ou électrique, tel que par exemple un moteur pas-à-pas.

25

6. Joint de direction selon l'une quelconque des revendications 1 à 5, **caractérisé en ce que** le piston différentiel (308)  
 est déplaçable axialement par une force, telle qu'une force hydraulique, et équipé de pistes tronconiques (316) sur  
 sa circonférence extérieure, les pistes tronconiques (316) étant engagées par des broches de contre-retention (313)  
 fixées ou reliées à la tubulure supérieure (301), de telle façon qu'un mouvement axial du piston différentiel (308)  
 entraîne une rotation du piston différentiel (308) par rapport à la tubulure inférieure (302), et une force de rappel  
 est fournie par un ressort mécanique (307) disposé entre le piston différentiel (308) et une face intérieure de la  
 tubulure inférieure (302).

30

7. Joint de direction selon l'une quelconque des revendications 1 à 5, **caractérisé en ce que** le piston différentiel (308)  
 est accouplé à au moins un piston hydraulique (317) en forme de section annulaire et circonferentiel, lequel est  
 maintenu dans un boîtier de rotateur annulaire (326) à l'aide d'un support (315) de manière à pouvoir être déplacé  
 progressivement dans le boîtier de rotateur (326) avec application d'un fluide hydraulique, et une rotation progressive  
 du piston hydraulique (317) résulte dans une rotation progressive du piston différentiel (308).

35

8. Joint de direction selon la revendication 7, **caractérisé en ce qu'au** moins un support (315) s'engage avec des  
 pistes tronconiques (316) orientées axialement sur la surface extérieure du piston différentiel (308) afin d'accoupler  
 de façon rotative le piston différentiel (308) avec le piston hydraulique (317).

40

9. Joint de direction selon la revendication 7 ou 8, **caractérisé en ce que** le piston hydraulique (317) recouvre une  
 section annulaire typiquement comprise entre 20° et 40°, de préférence de 30° de la circonférence du piston diffé-  
 rentiel (308).

45

10. Joint de direction selon l'une quelconque des revendications 7 à 9, **caractérisé en ce que** le piston hydraulique  
 (317) est équipé d'un élément de rappel élastique, tel qu'un ressort de rappel (320) destiné à renvoyer le piston  
 hydraulique (317) après chaque étape de rotation, de manière à obtenir une oscillation de type à cliquet du piston  
 hydraulique (317) par rapport au boîtier de rotateur (326).

50

11. Joint de direction selon l'une quelconque des revendications 7 à 10, **caractérisé en ce qu'au** moins un élément  
 élastique, tel qu'un ressort axial (321), est prévu sur la surface extérieure du piston différentiel (308) et pousse  
 contre un support de palier axial (322) afin d'exercer une force de rappel sur le piston différentiel (308).

55

12. Joint de direction selon l'une quelconque des revendications 1 à 11, **caractérisé en ce que** le joint universel (303)  
 est relâché pour fléchir librement dans une direction quelconque lorsqu'aucune force de pression n'est exercée sur

## EP 3 228 809 B1

le piston différentiel (308) afin de retirer le joint de direction après le fonctionnement.

- 5
13. Joint de direction selon l'une quelconque des revendications 1 à 12, **caractérisé en ce que** la position de rotation du piston différentiel (308) et/ou l'orientation directionnelle de la tubulure inférieure (302) par rapport à la tubulure supérieure (301) sont mesurées par un capteur électrique ou magnétique.
14. Système de forage orientable, comprenant un joint de direction (3) selon l'une quelconque des revendications précédentes.
- 10
15. Système de forage orientable selon la revendication 14, comprenant en outre une tête de forage (1), un moteur hydraulique (2), un système de contre-retenu (4), un élément tubulaire (5), un manchon de protection (6) et/ou un système de propulsion magnétique.

15

20

25

30

35

40

45

50

55

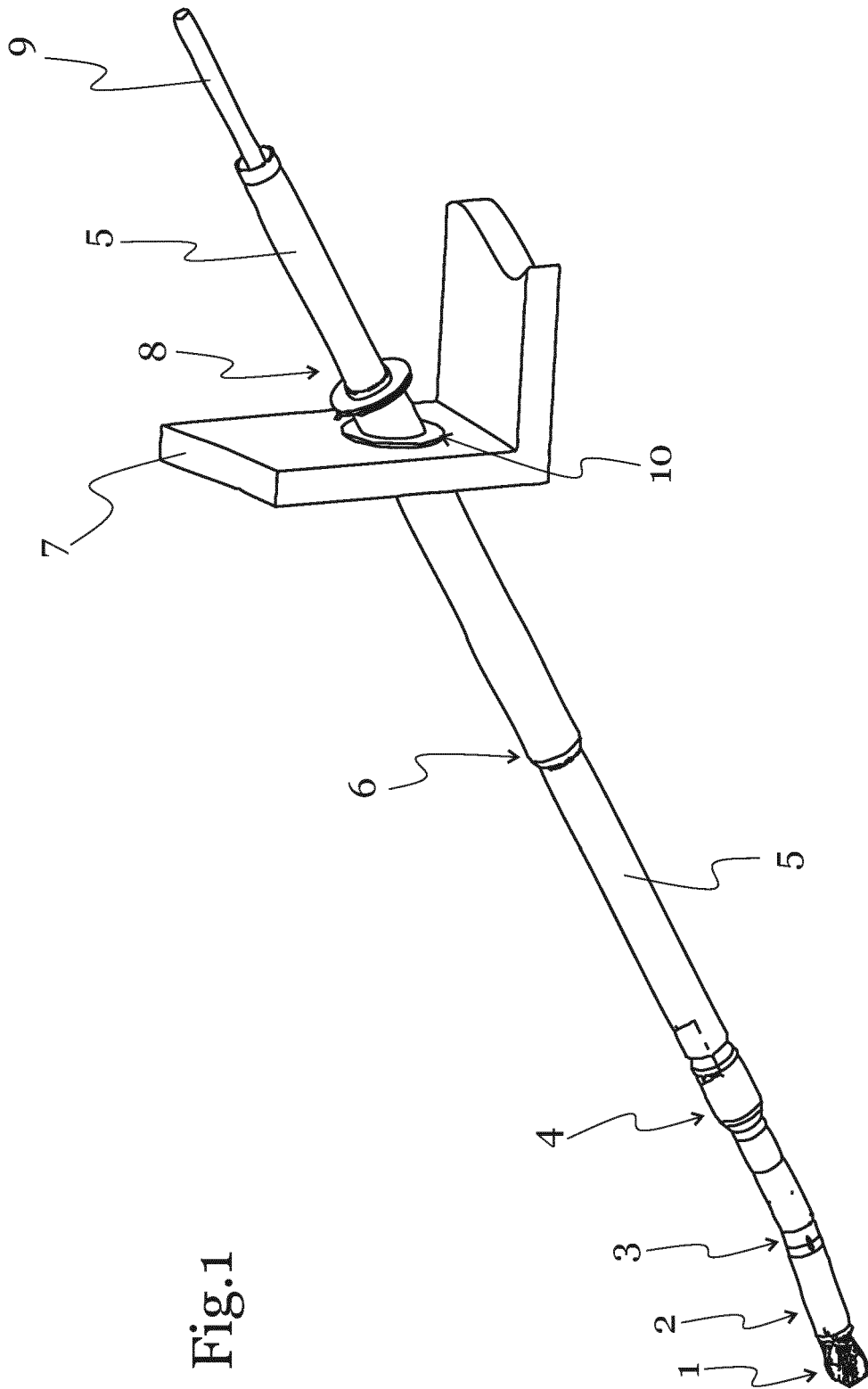
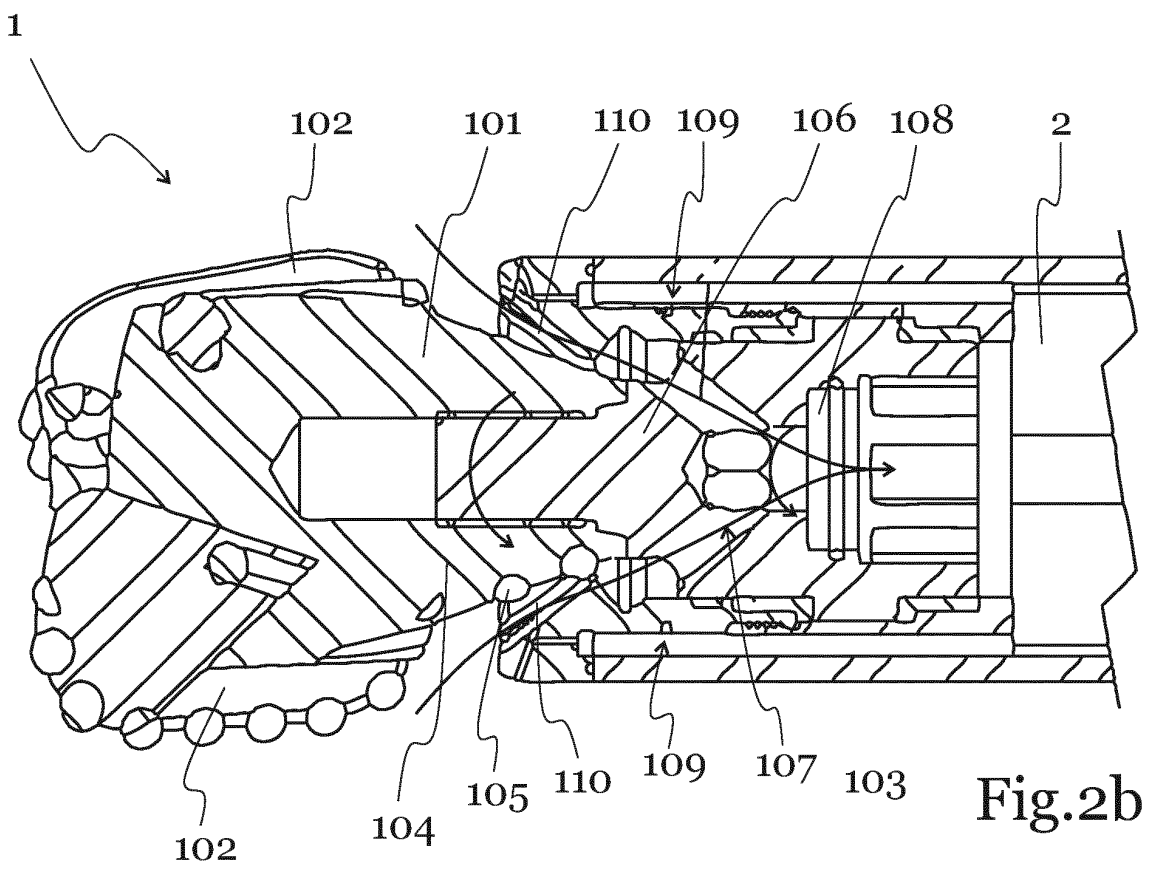
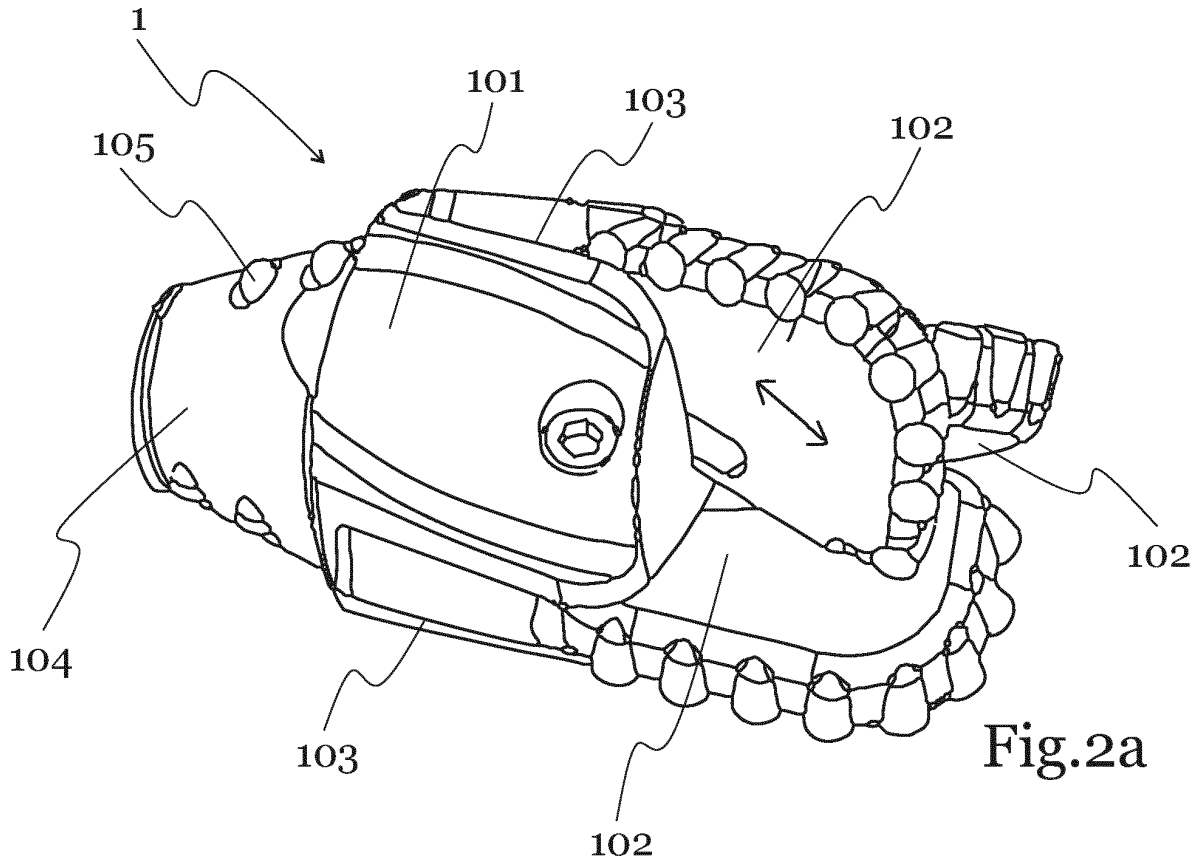
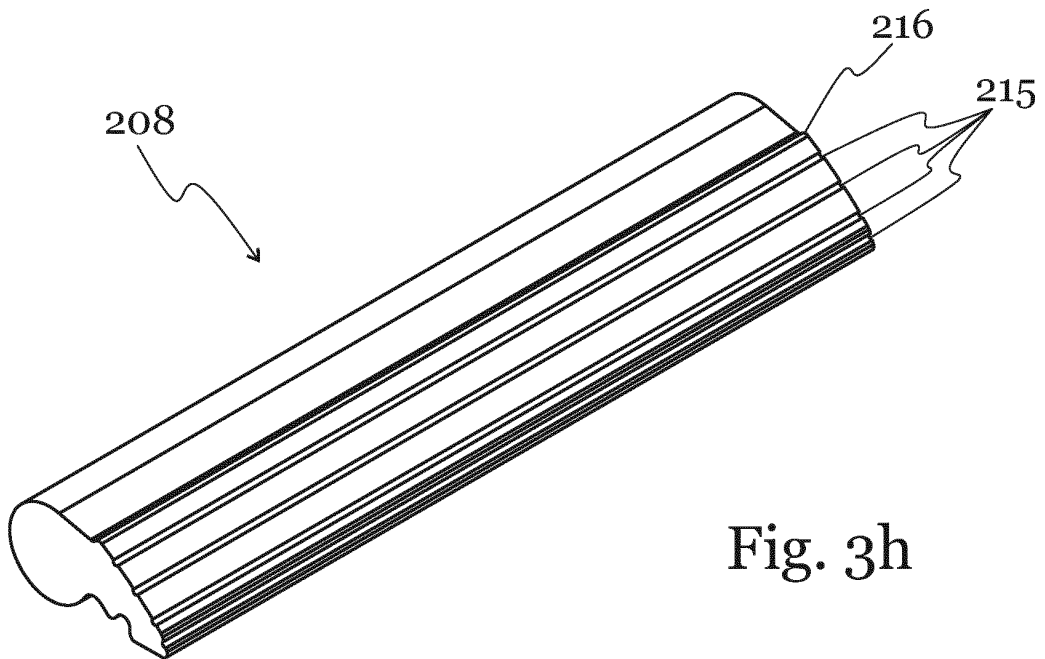
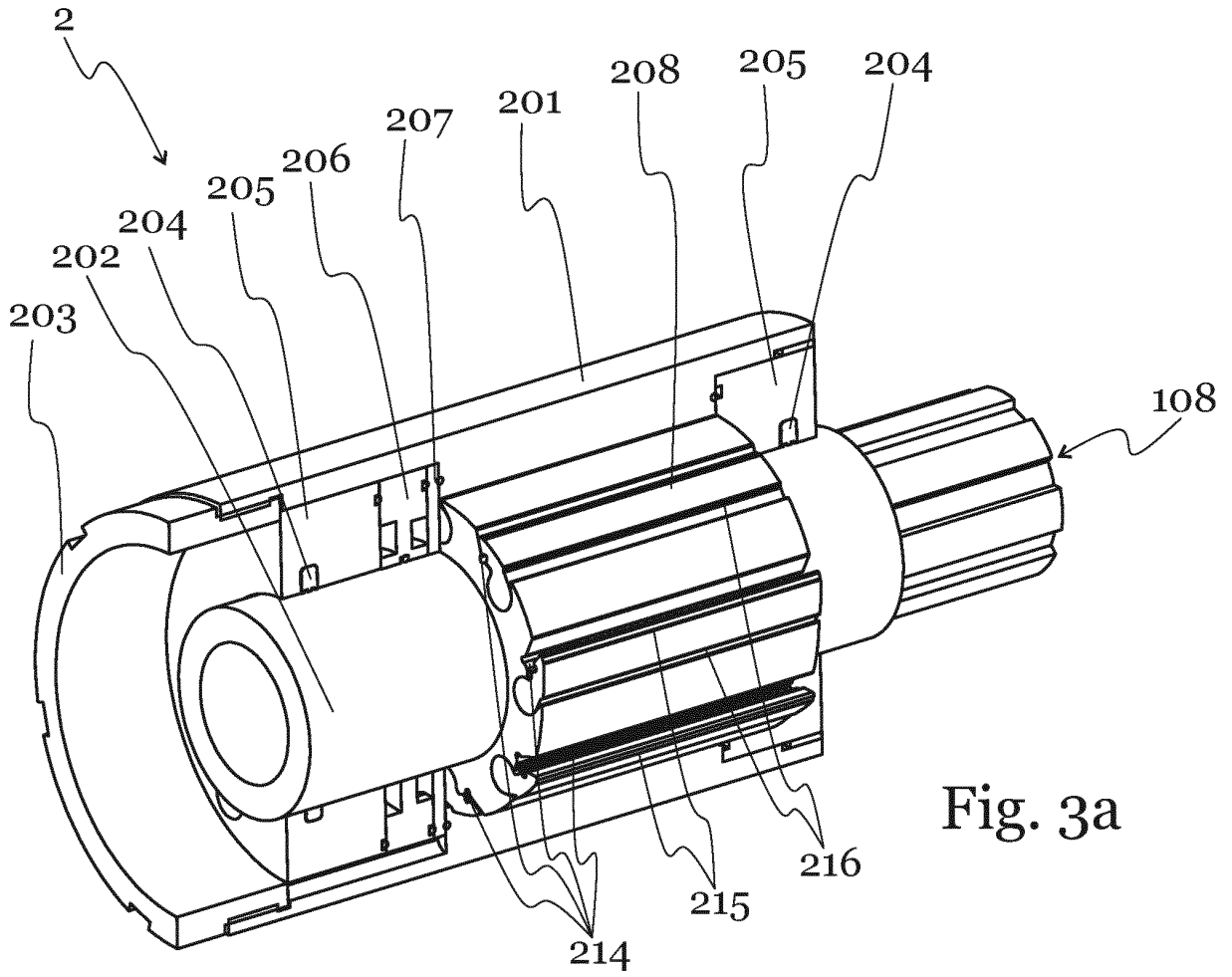

Fig.1







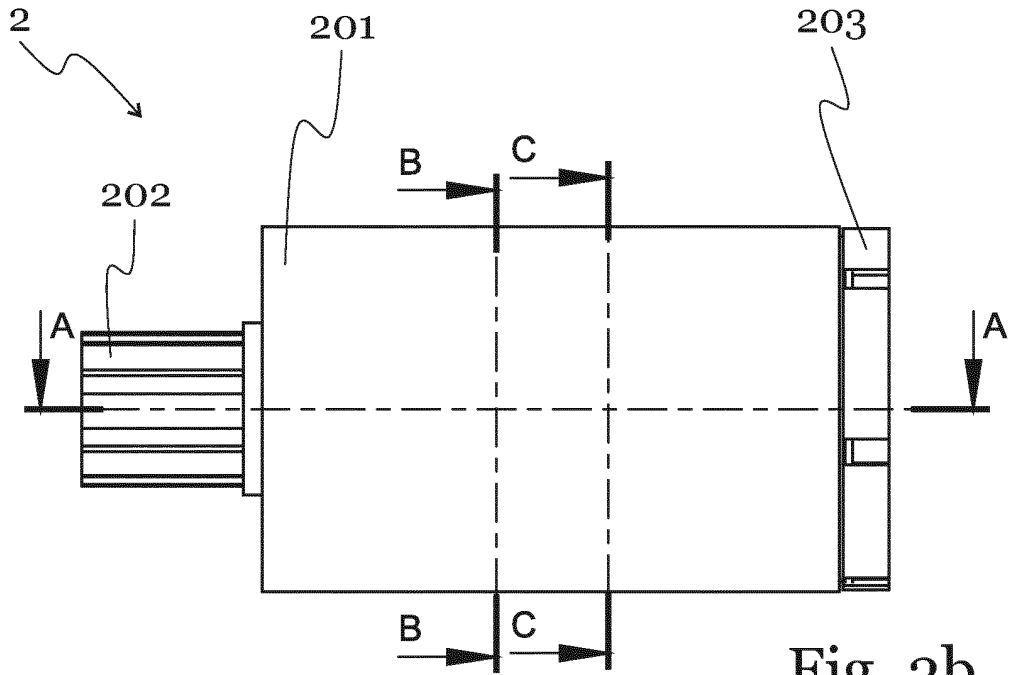
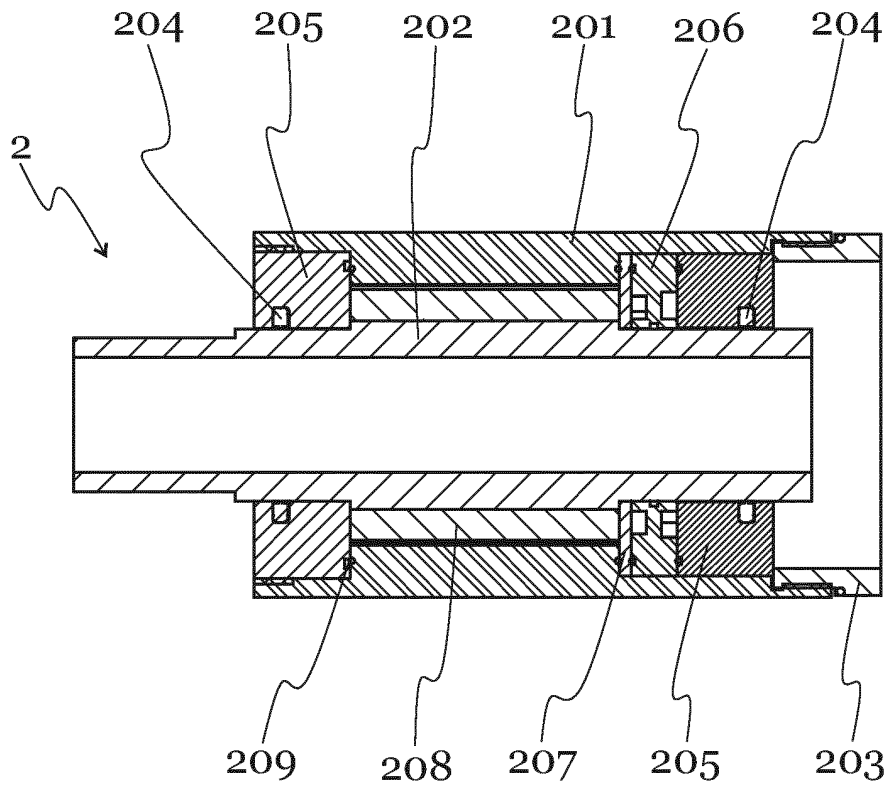

Fig. 3b



A-A

Fig. 3c

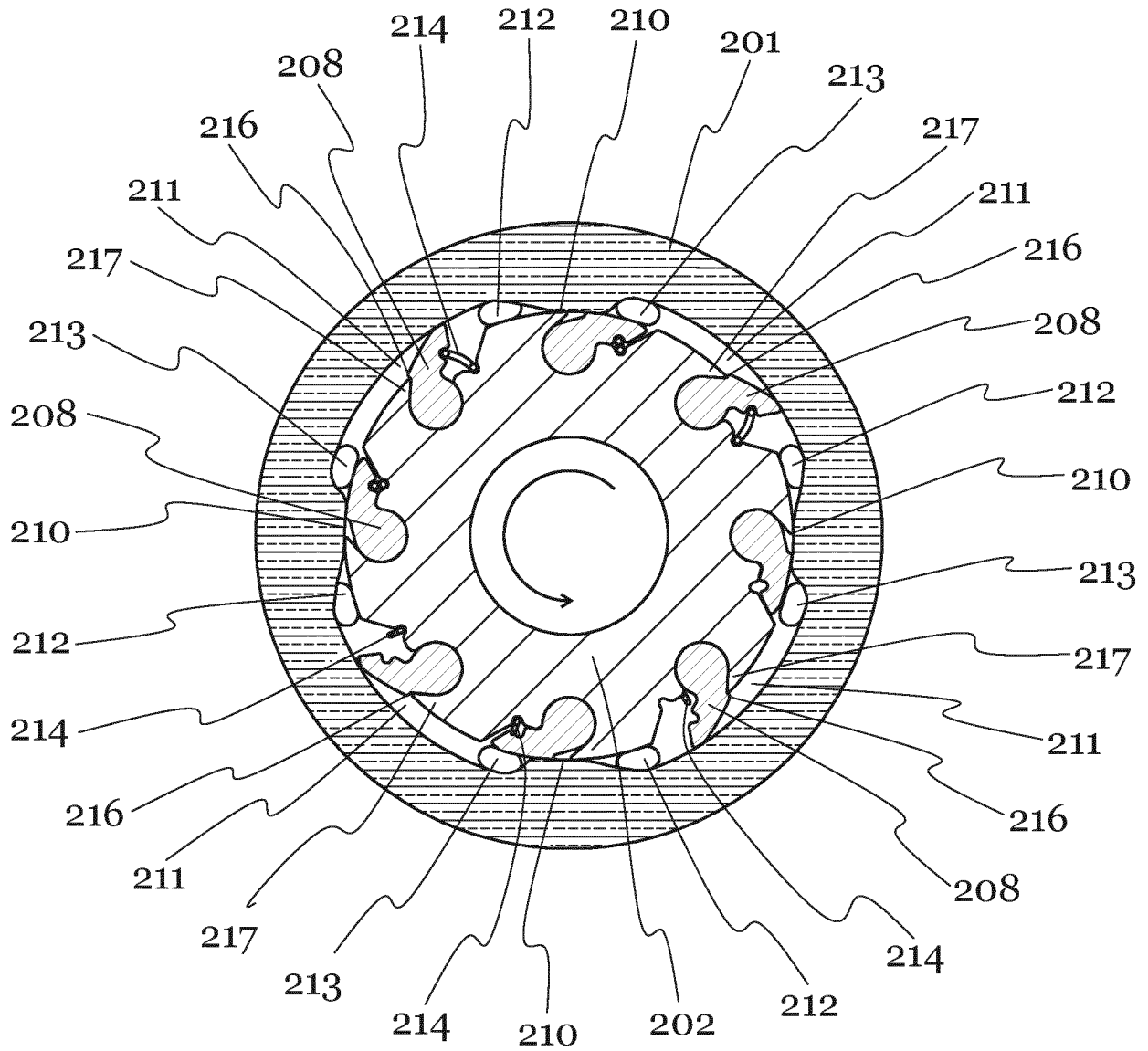

Fig. 3d

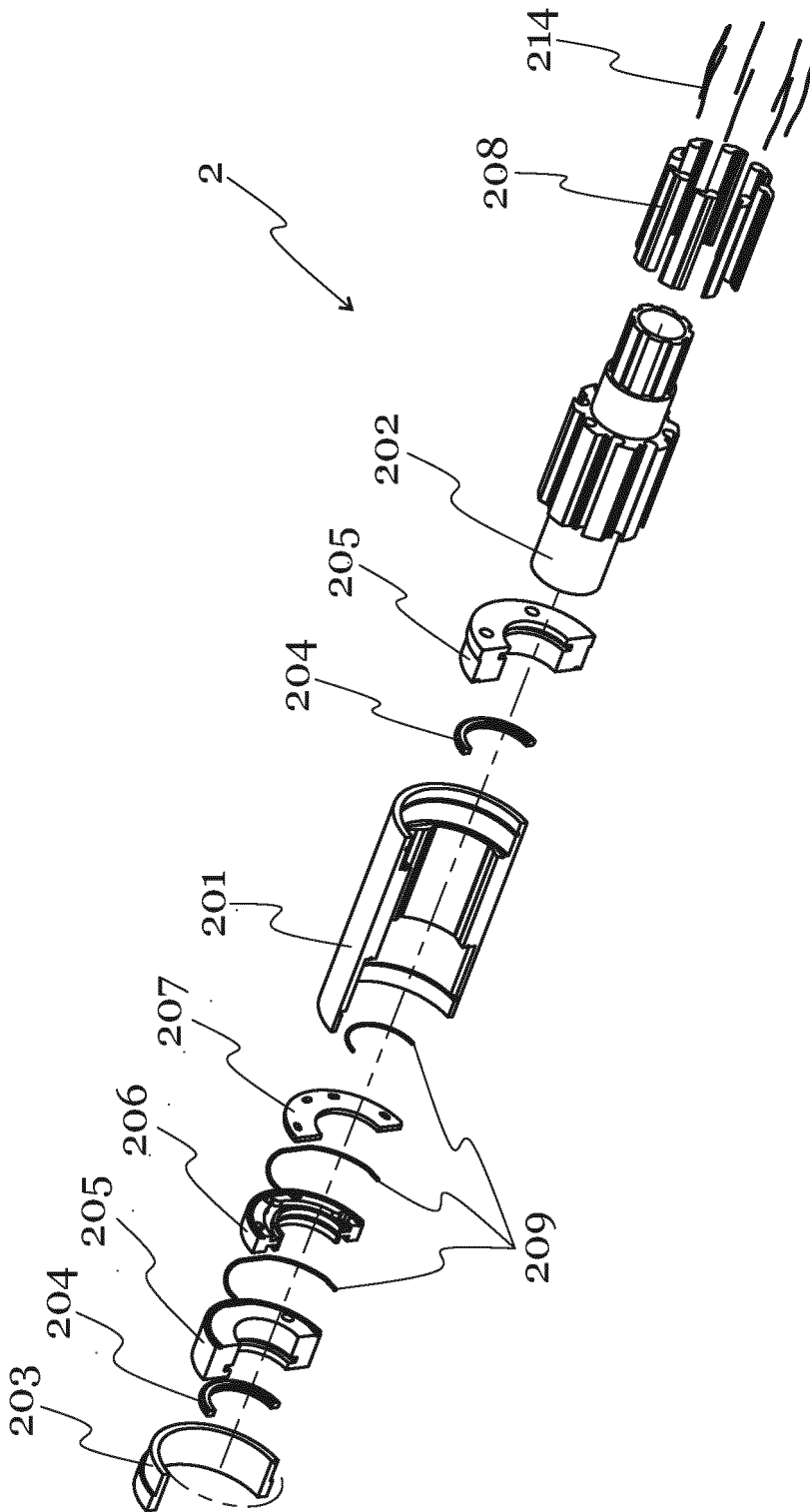

Fig.3e

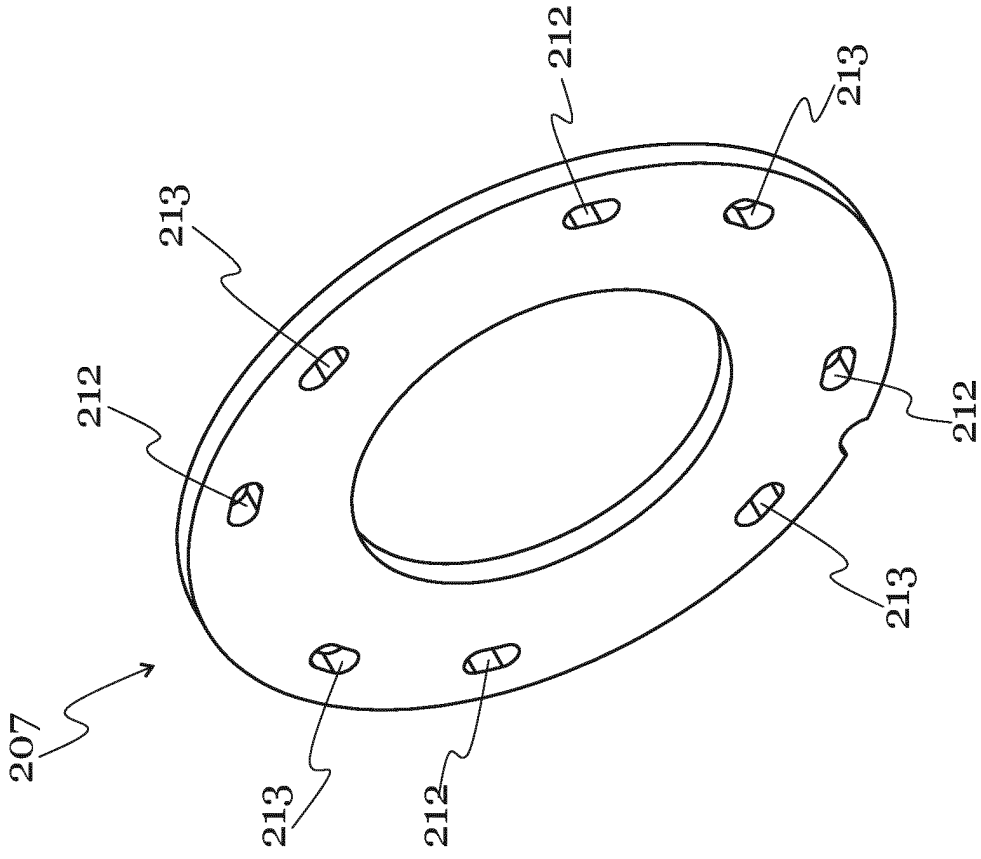

Fig. 3g

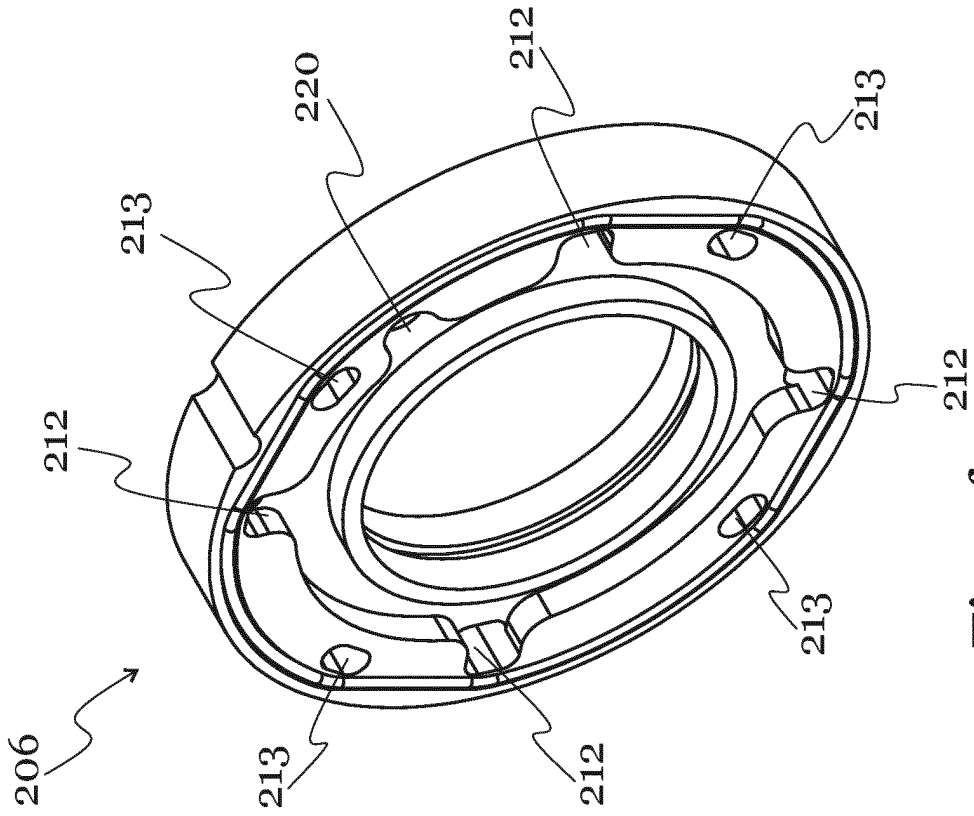
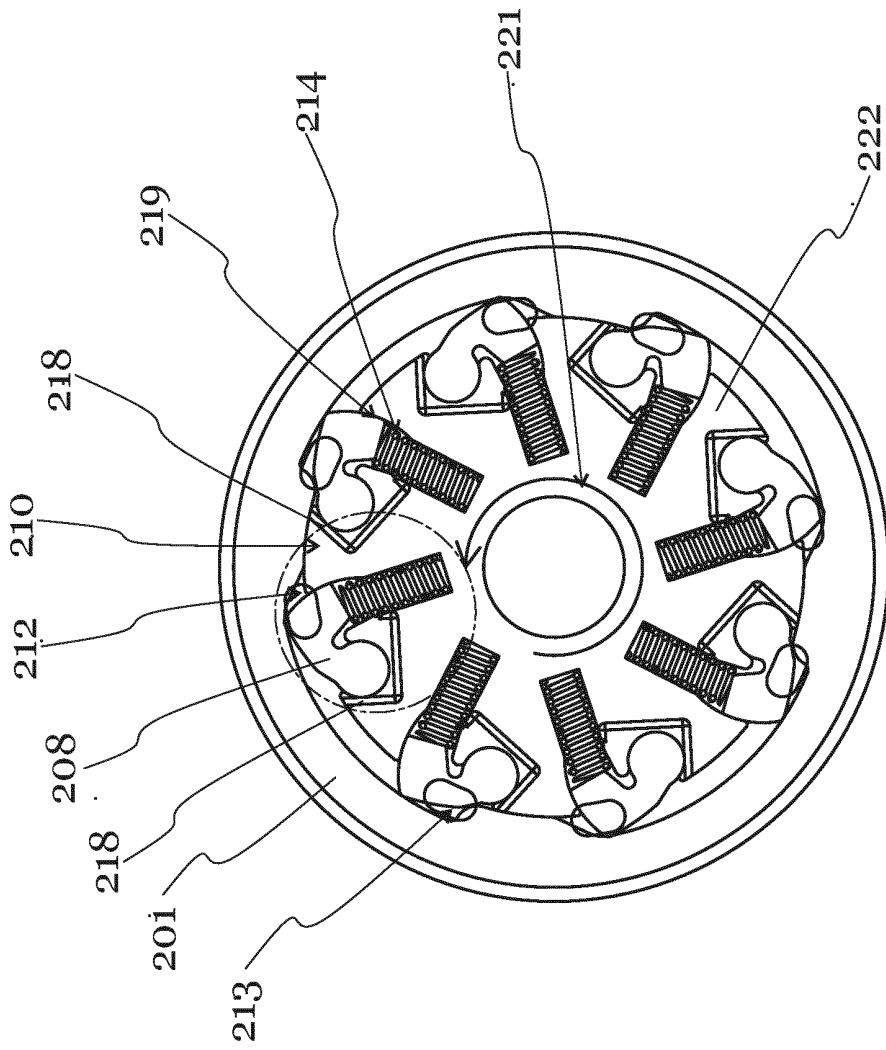
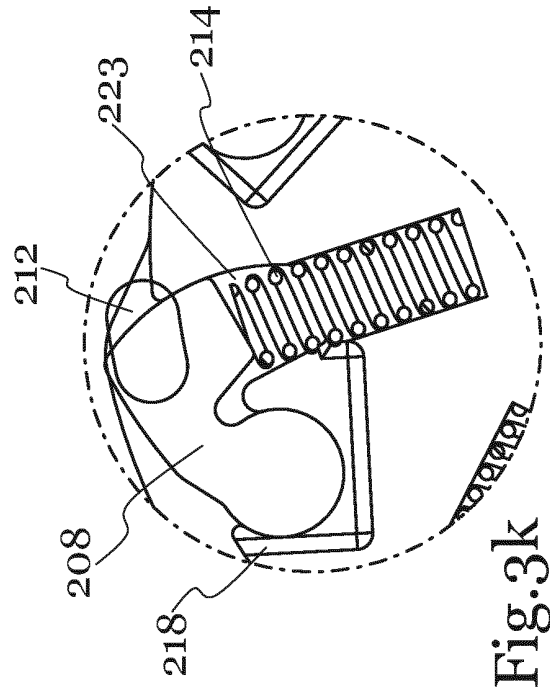
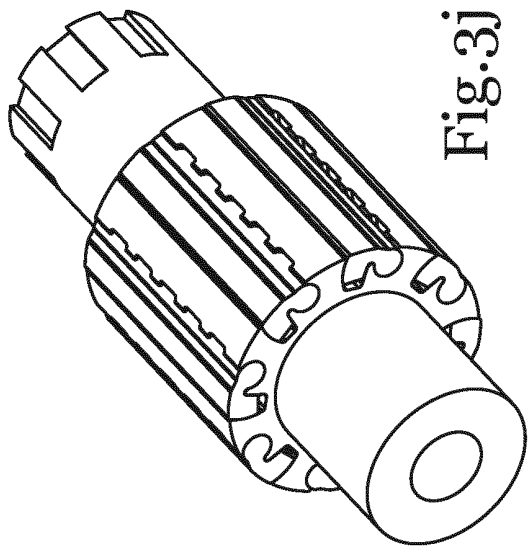

Fig. 3f



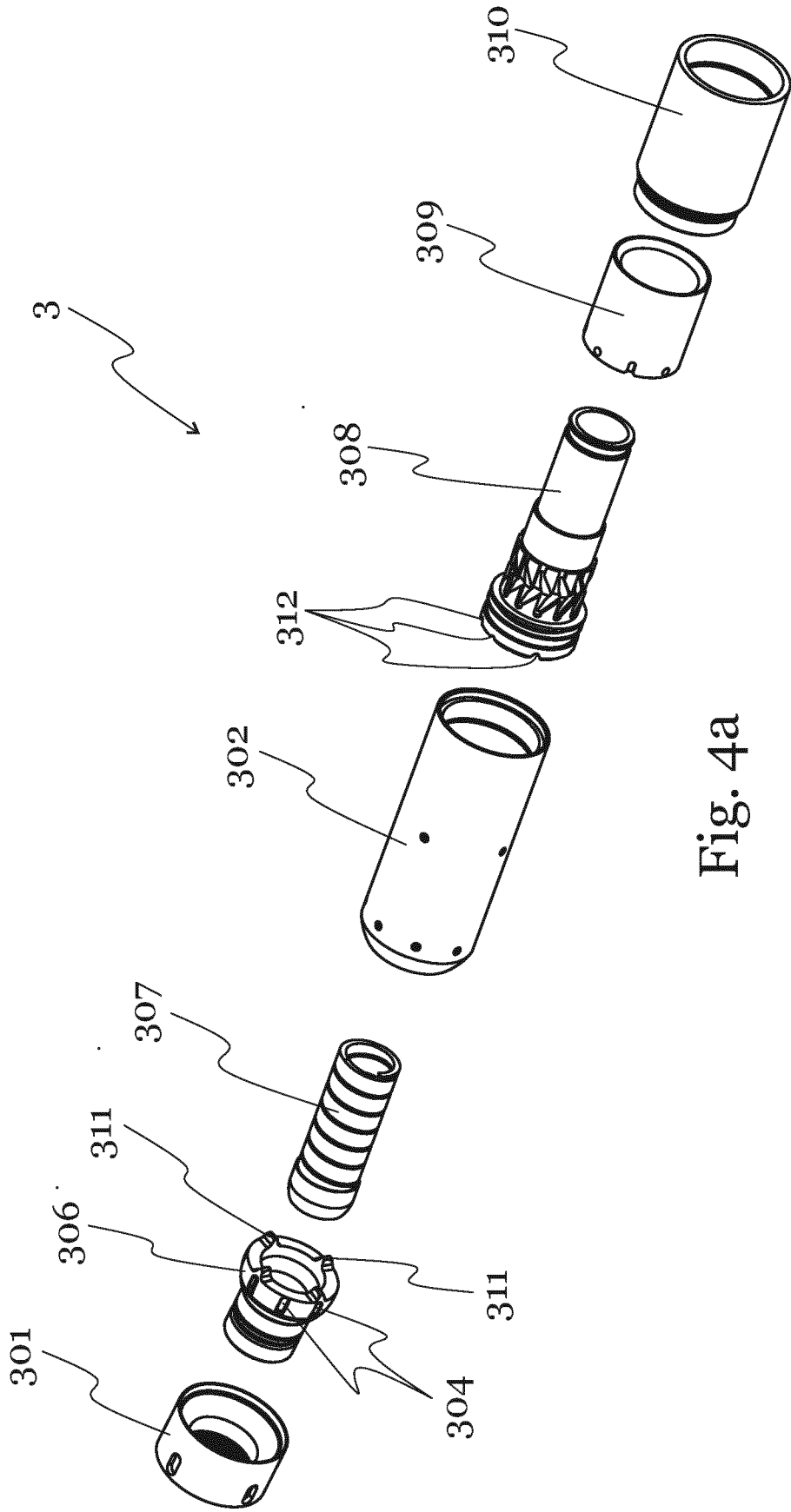
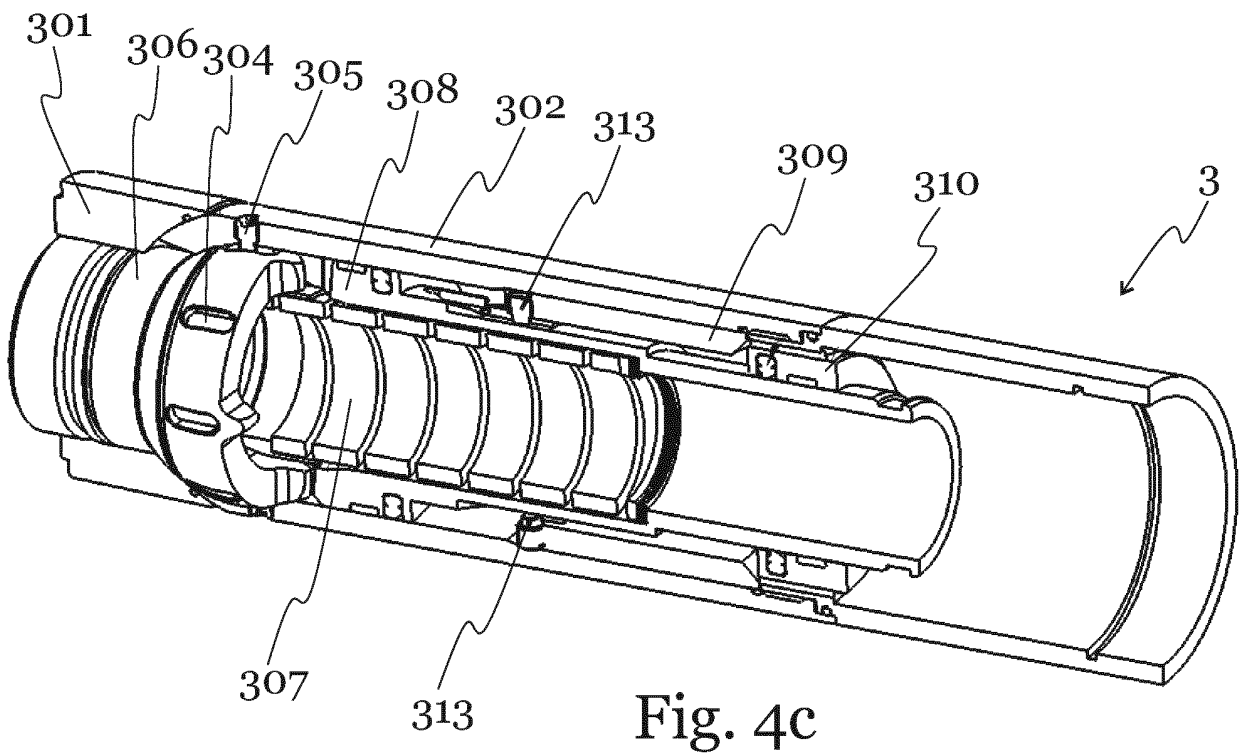
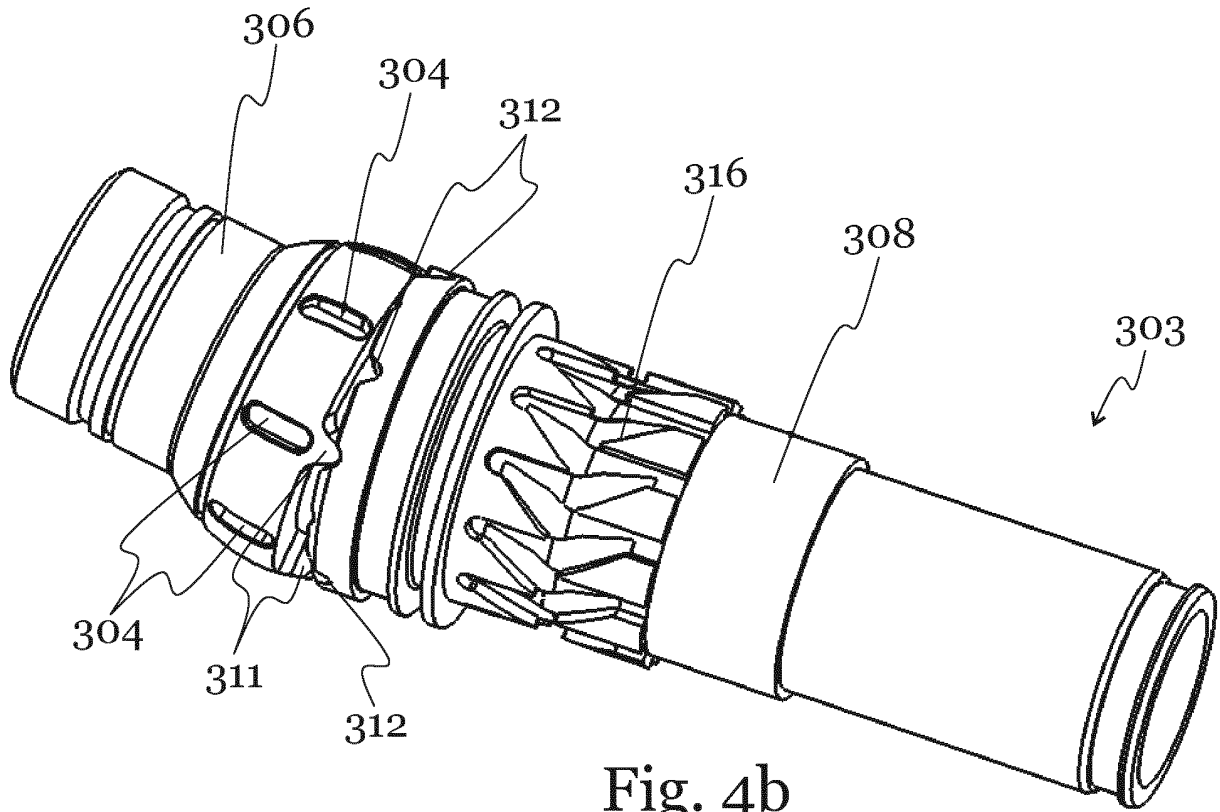
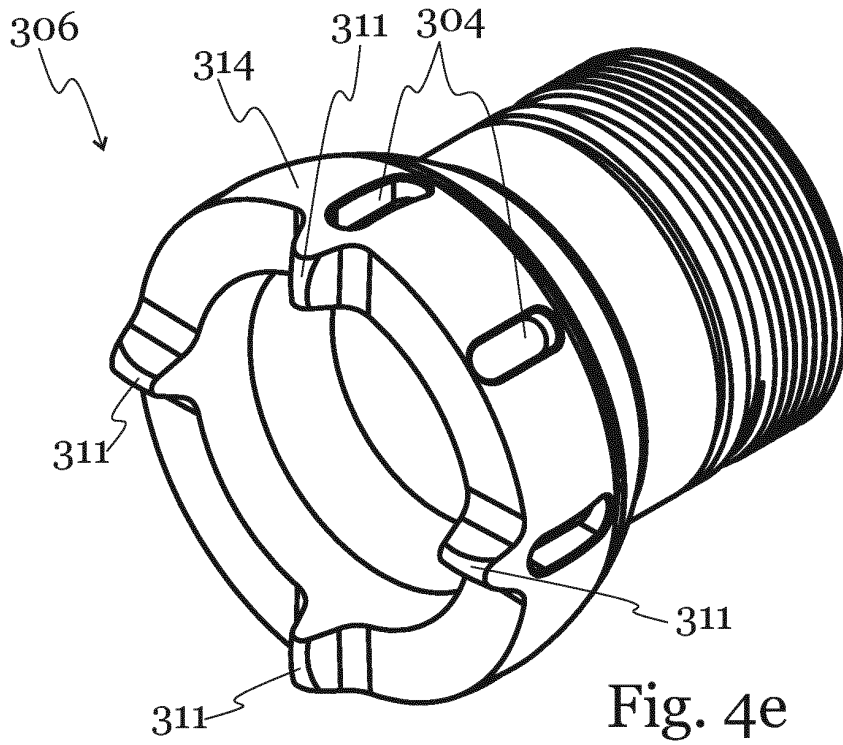
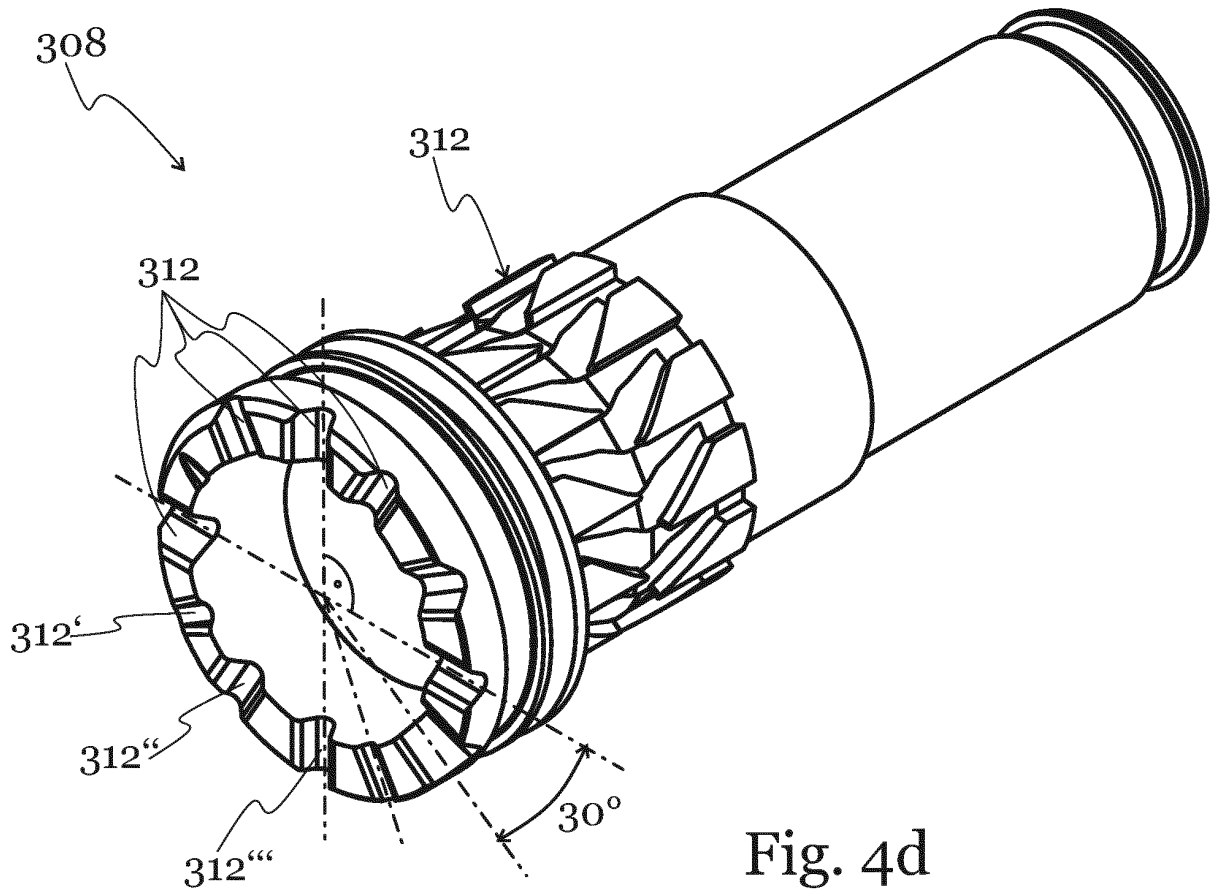

Fig. 4a







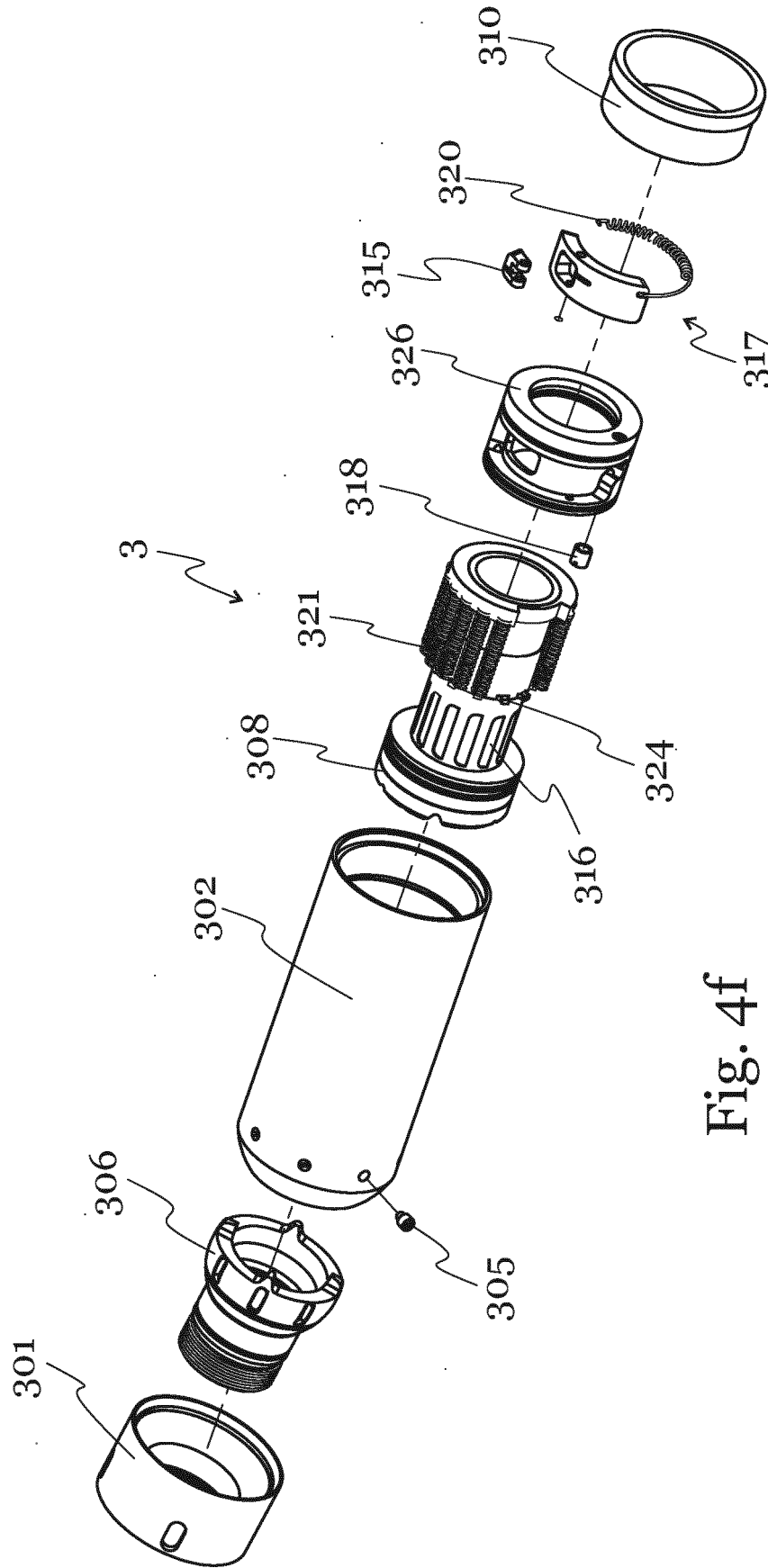
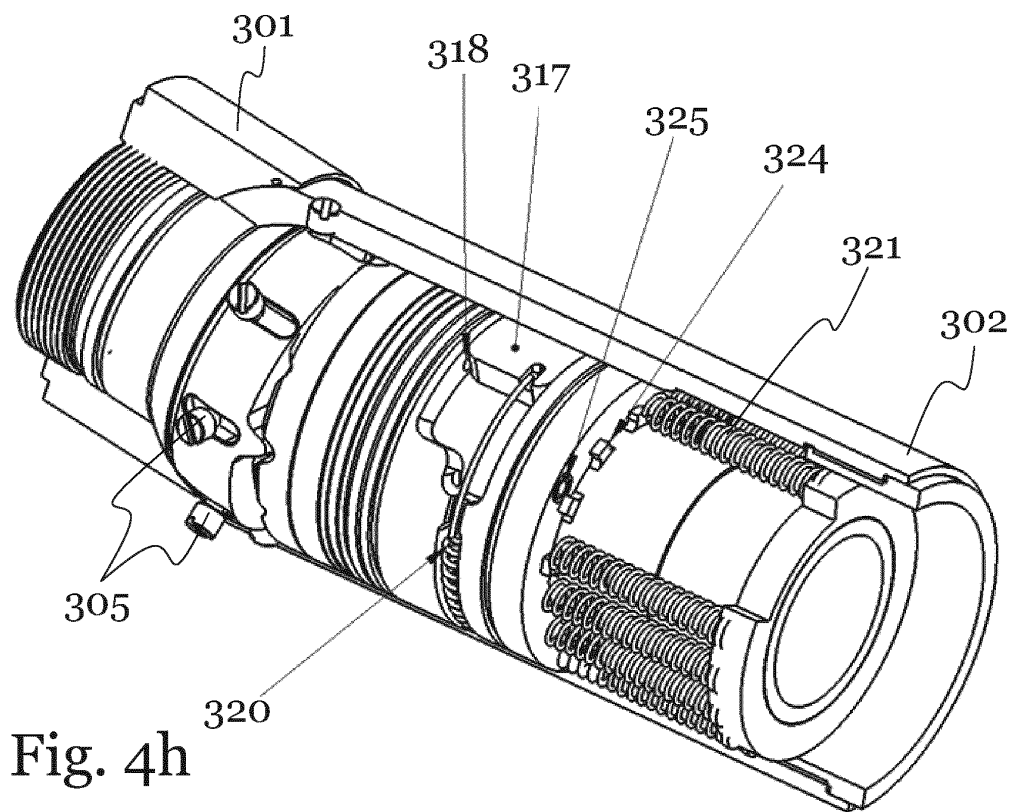
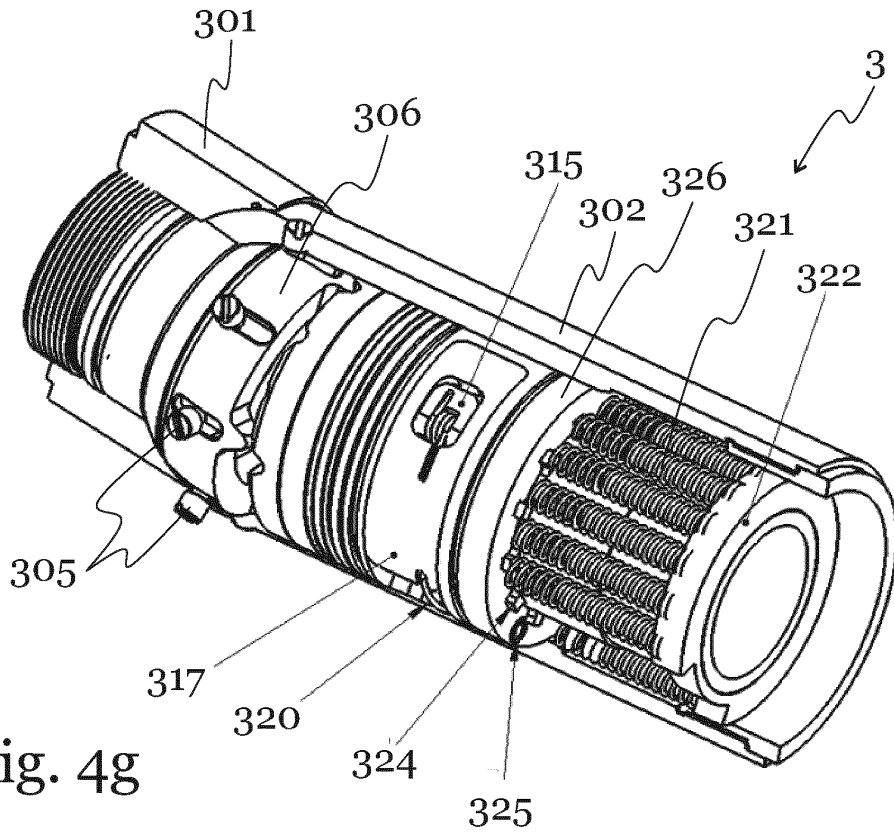

Fig. 4f



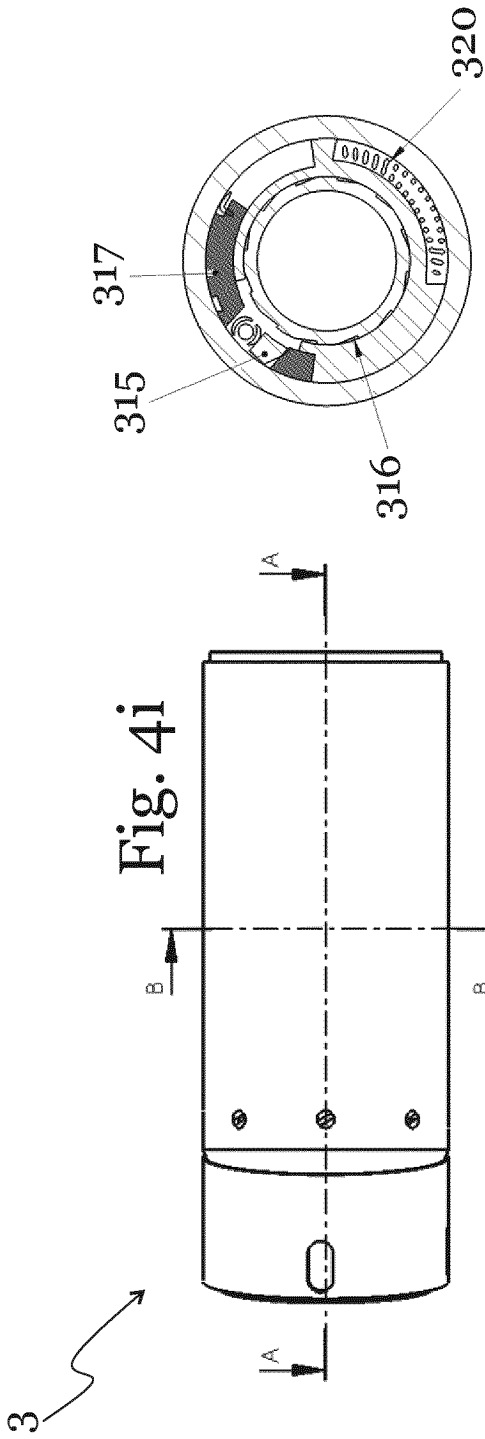
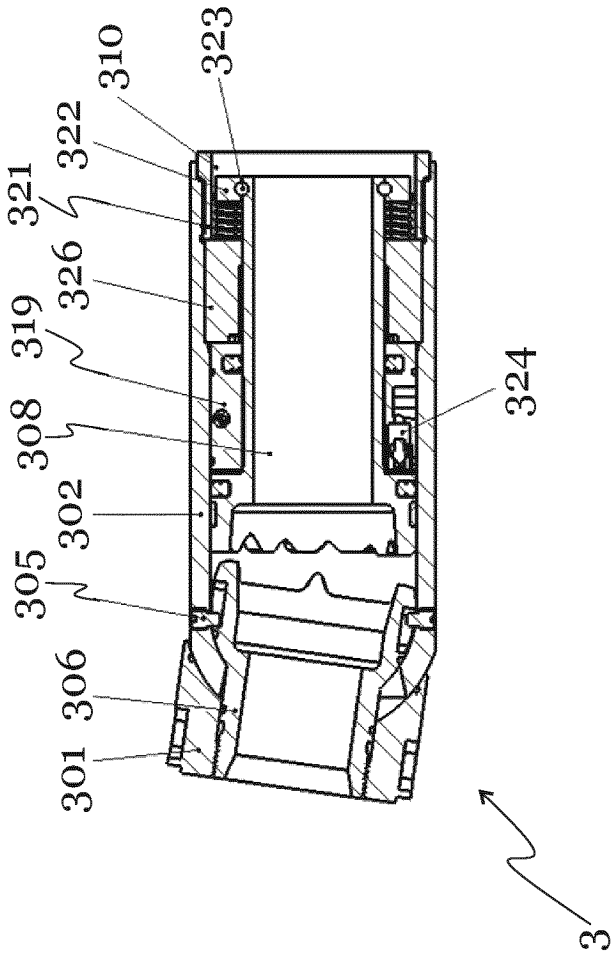
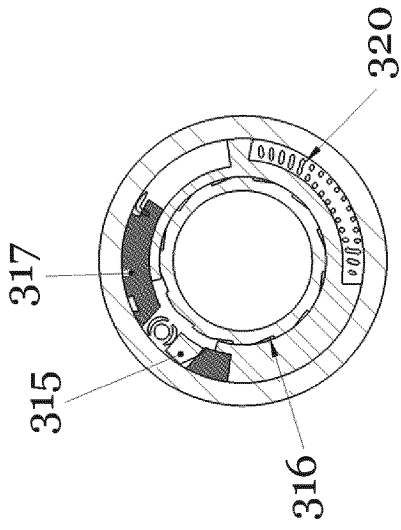

Fig. 4k



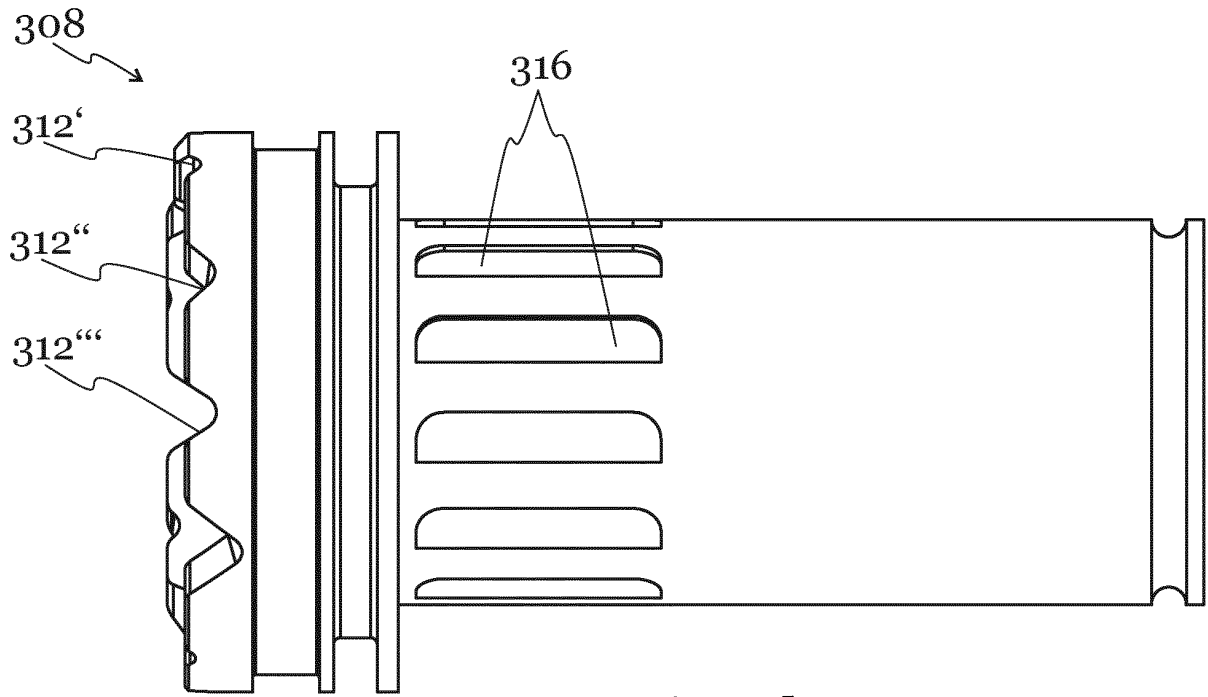

Fig. 4l

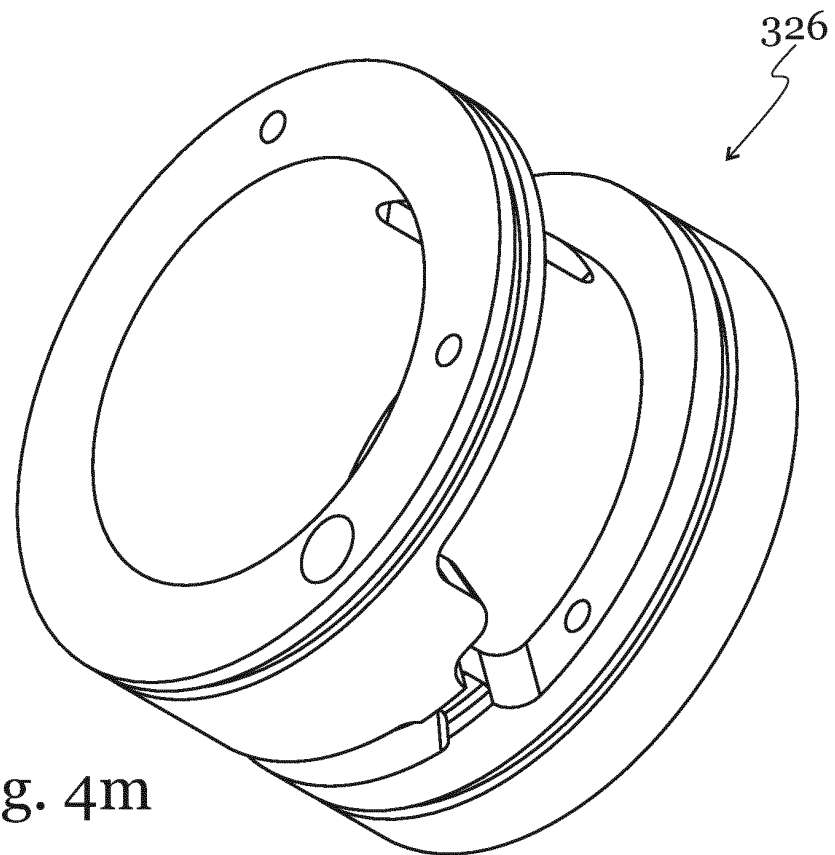

Fig. 4m



Fig. 5a

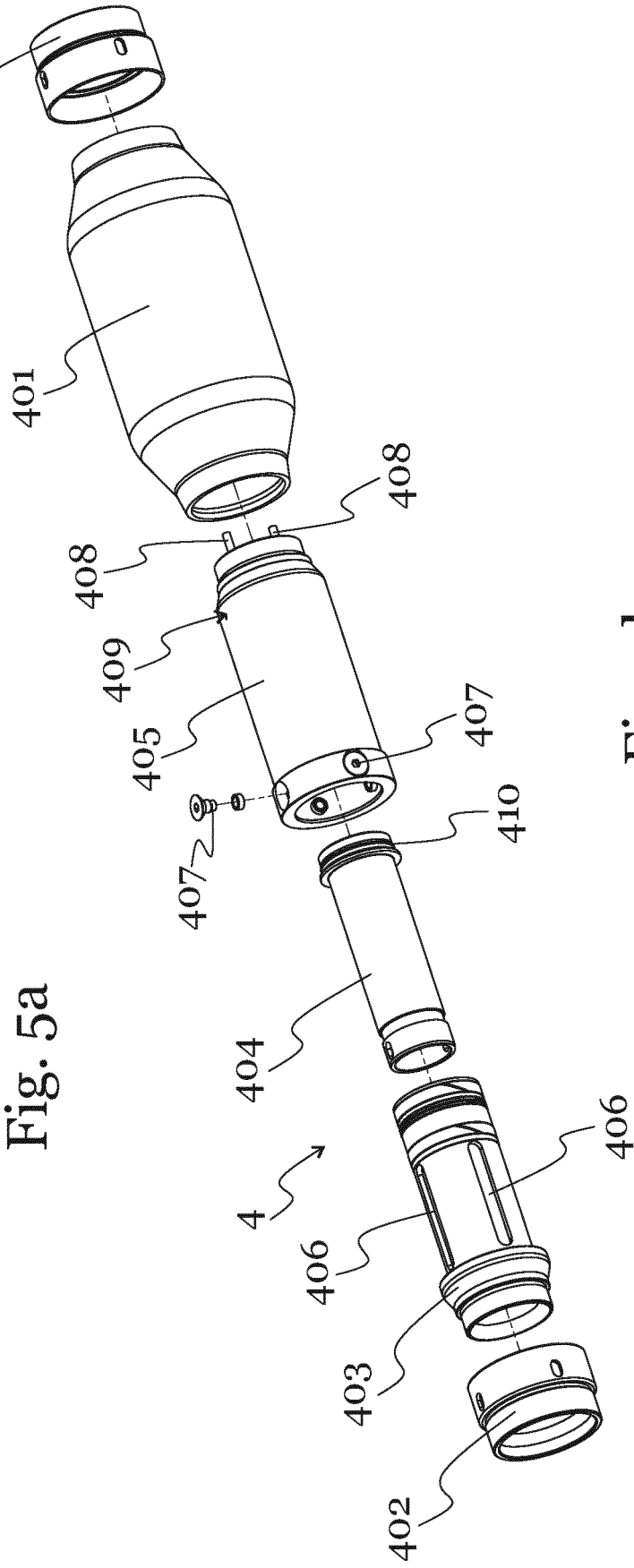

Fig. 5b

Fig. 5c

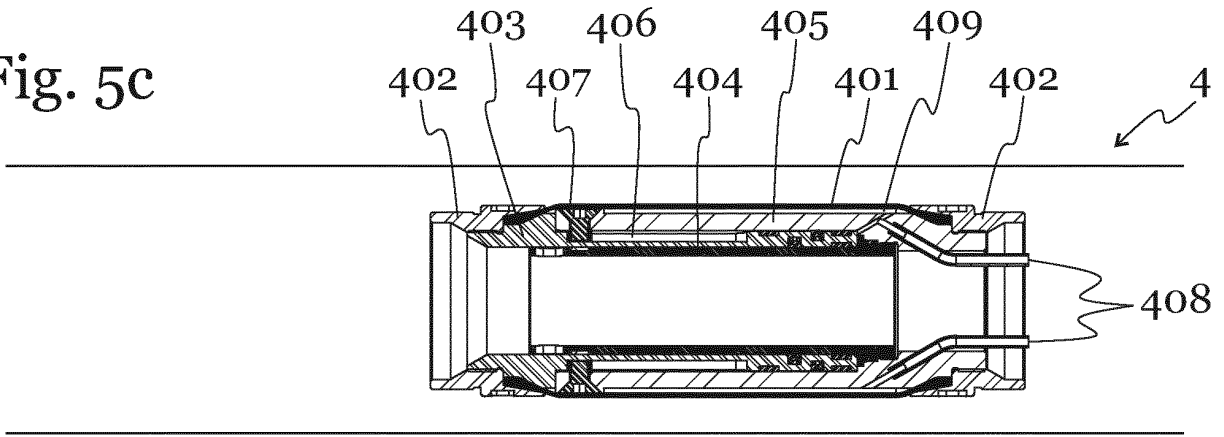

Fig. 5d

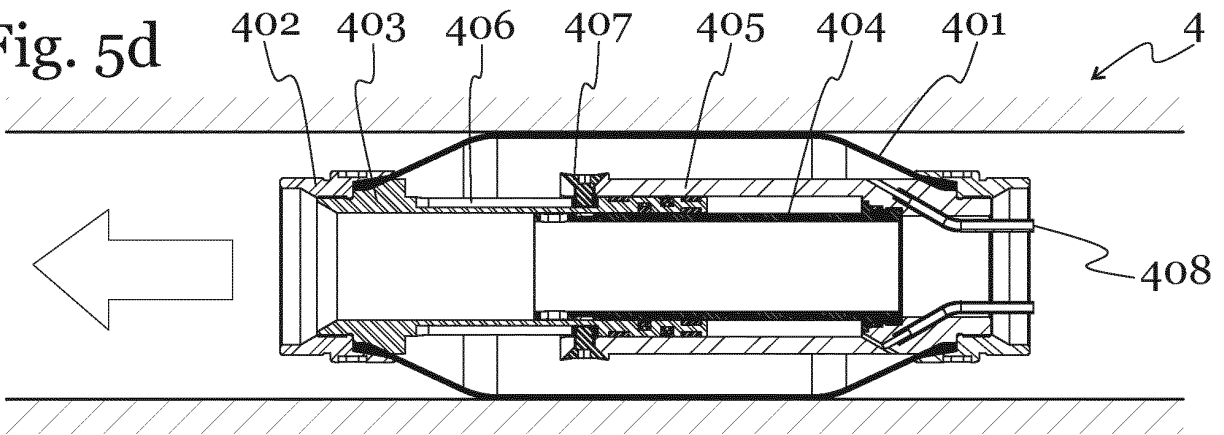
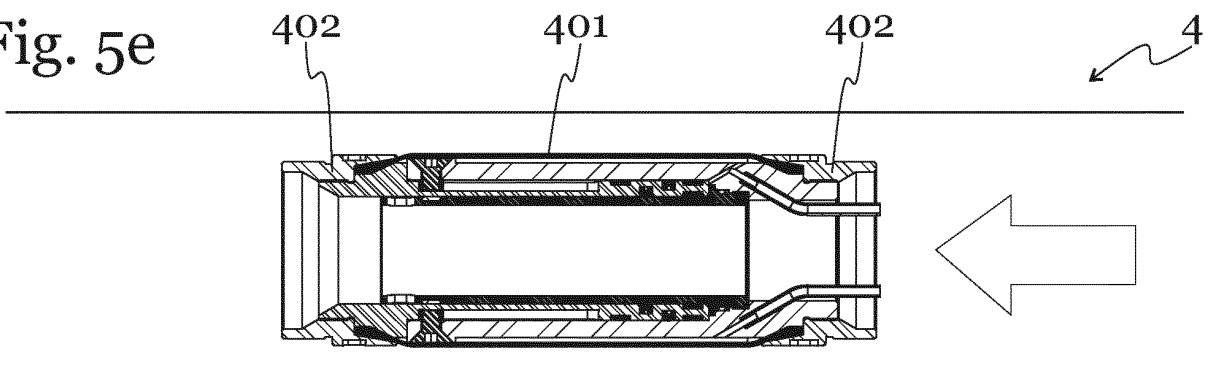

Fig. 5e





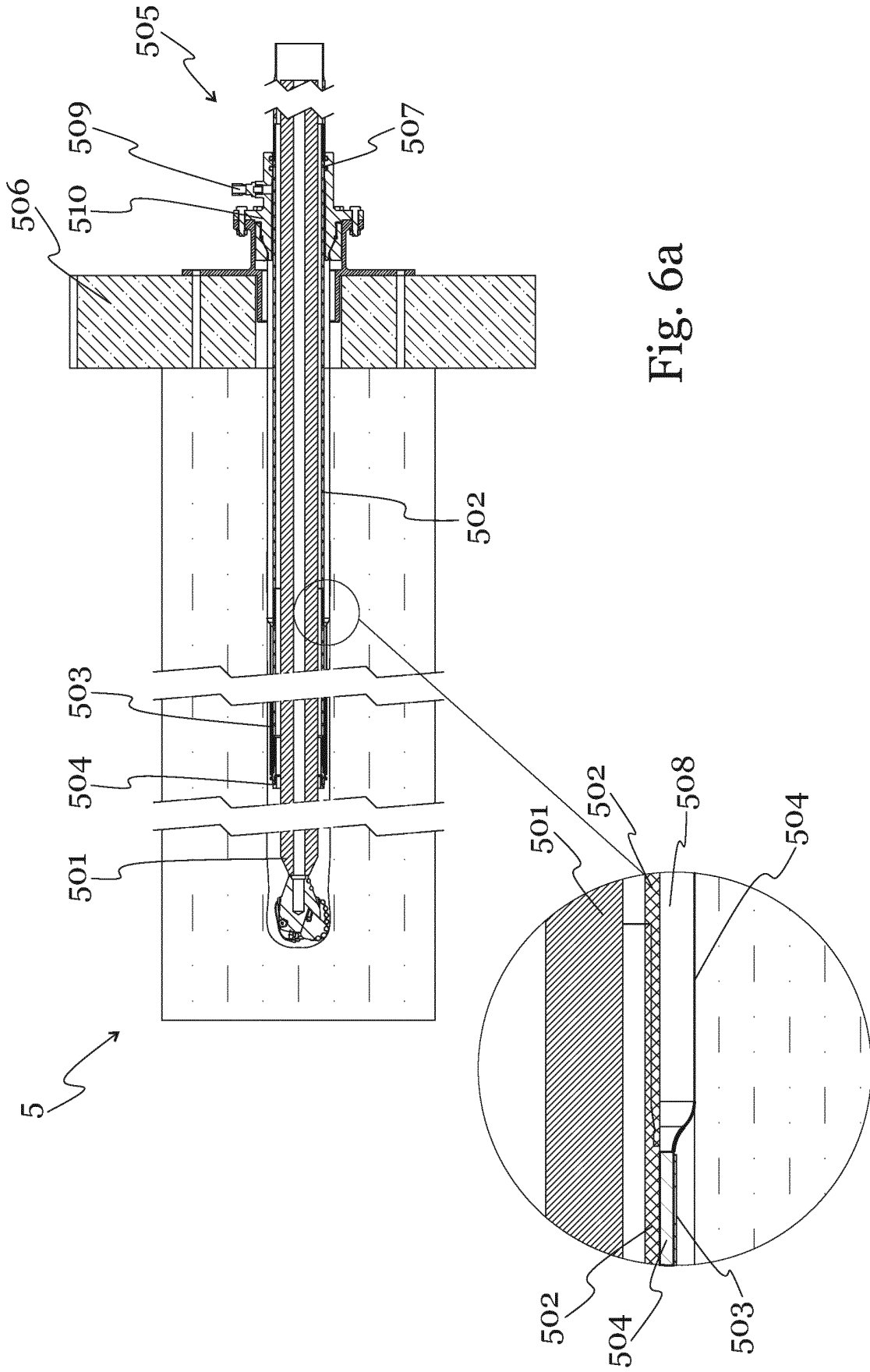

Fig. 6a

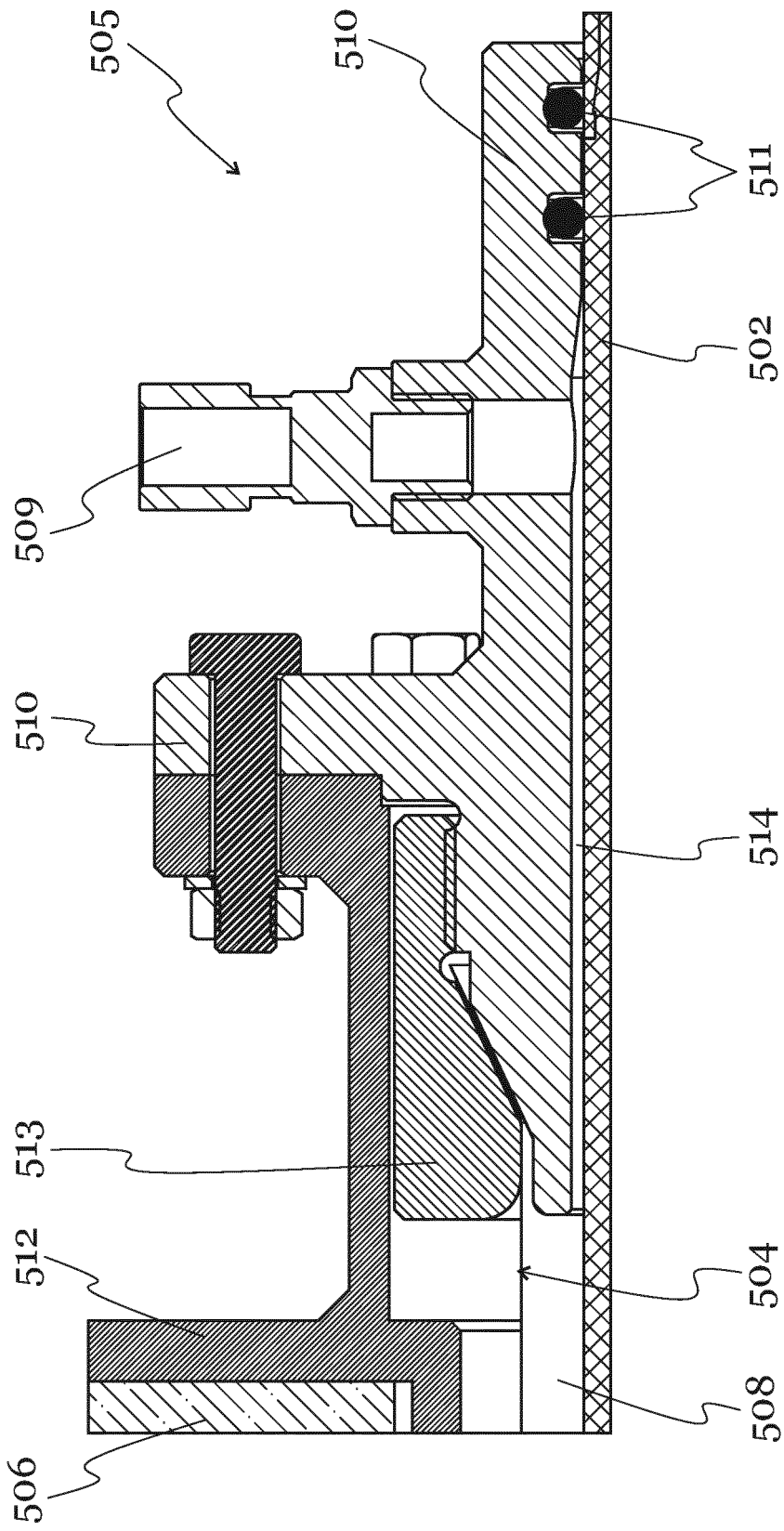

Fig. 6b



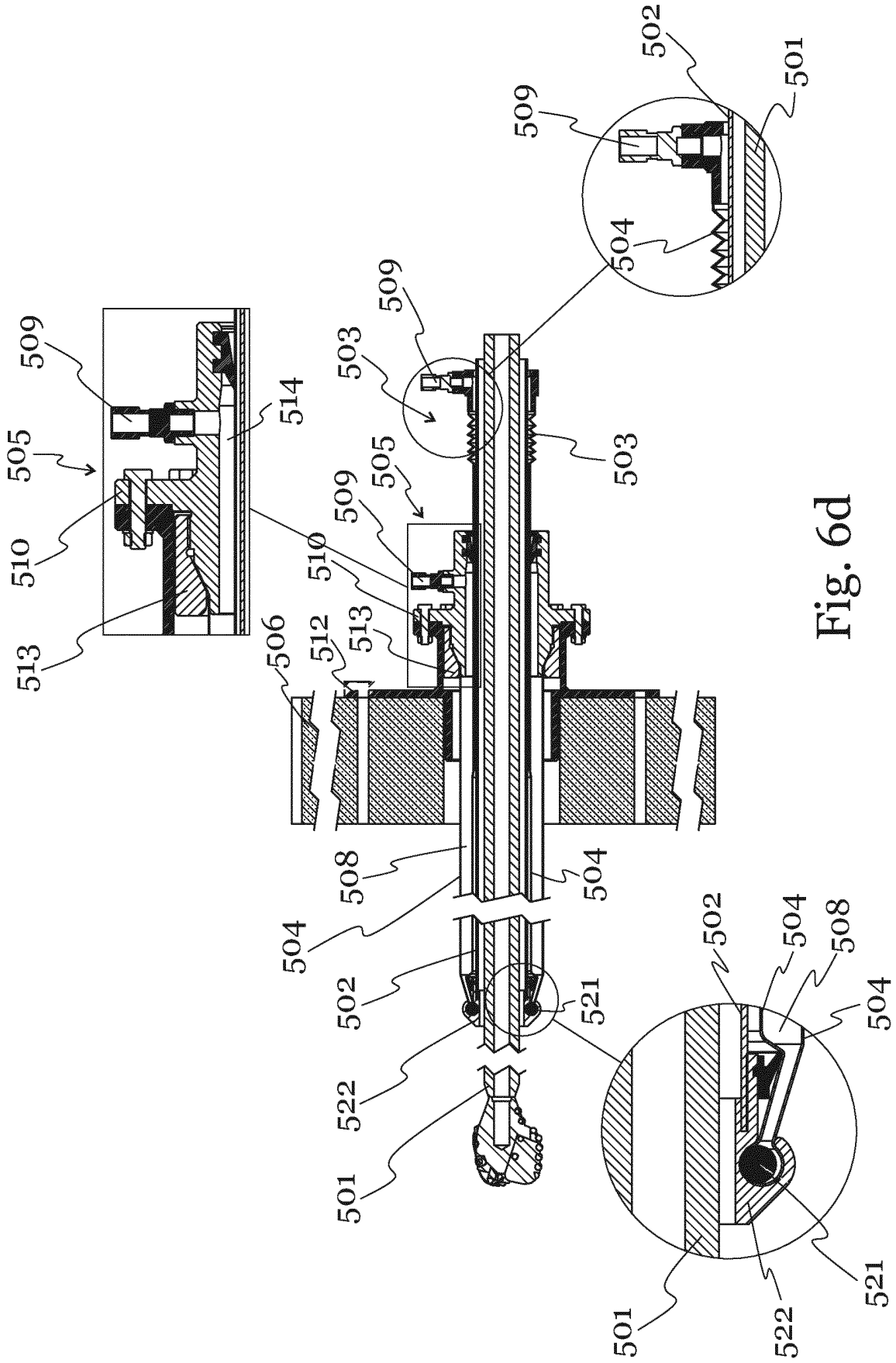

Fig. 6d

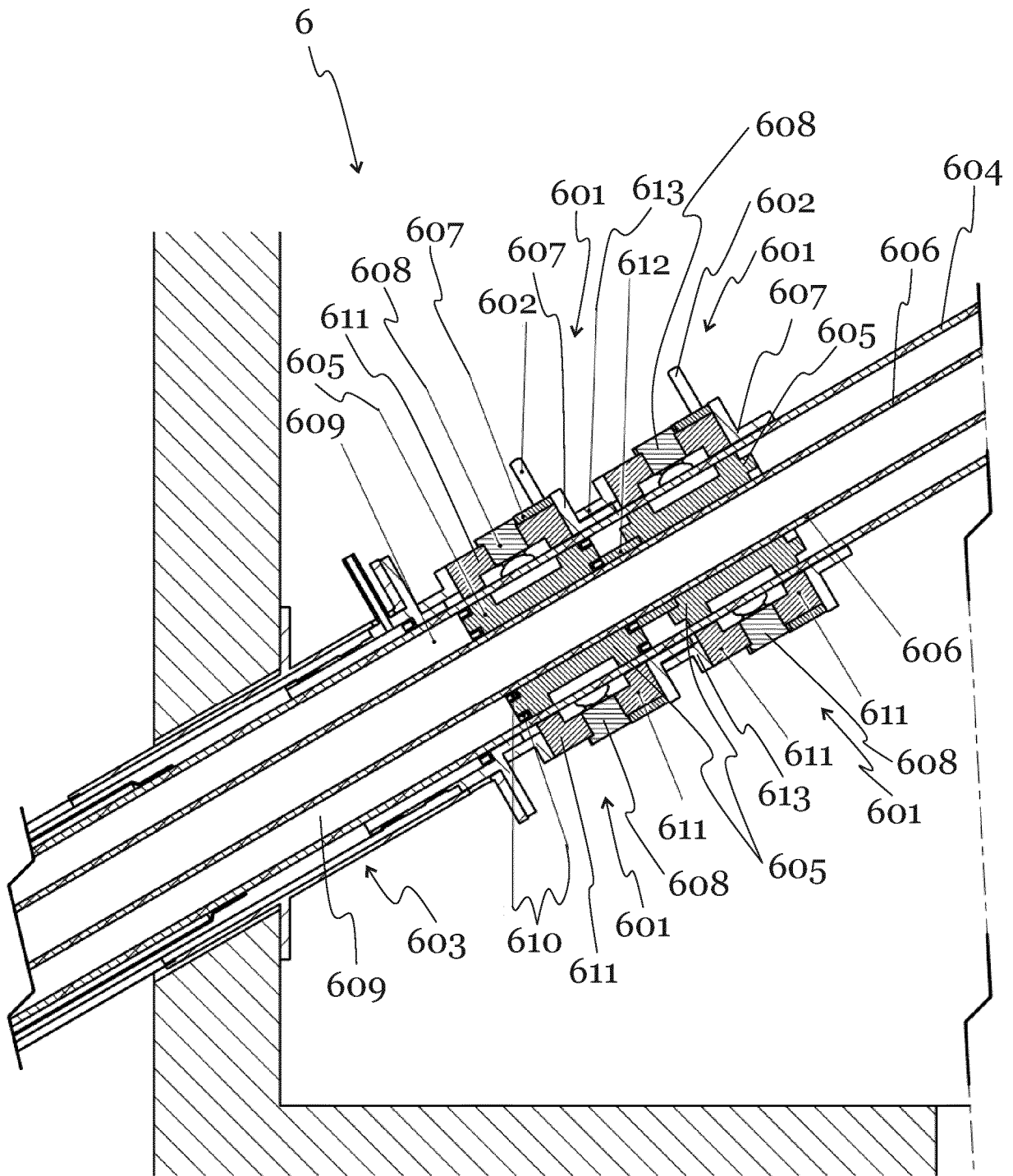

Fig. 7a

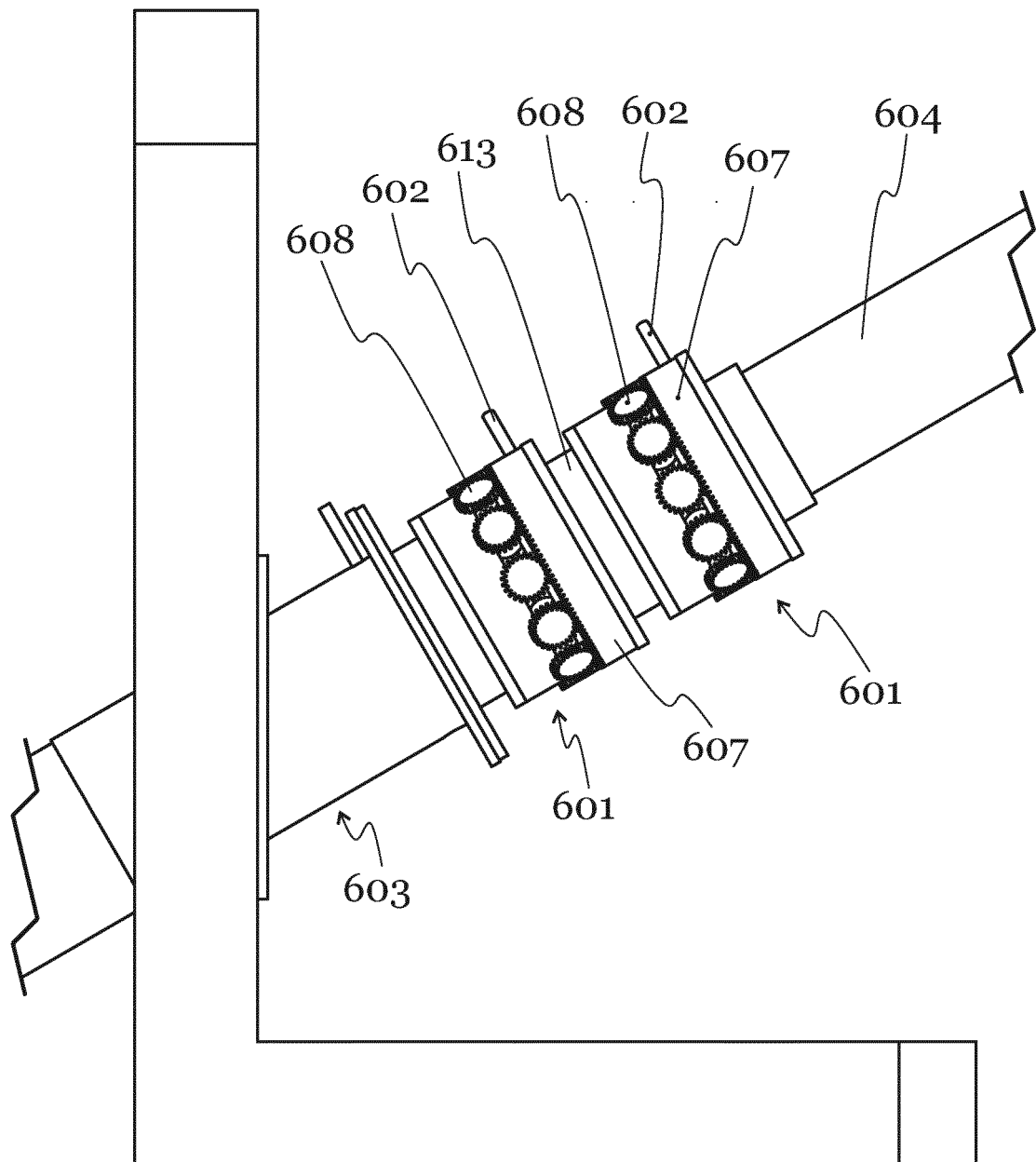

Fig. 7b

**REFERENCES CITED IN THE DESCRIPTION**

*This list of references cited by the applicant is for the reader's convenience only. It does not form part of the European patent document. Even though great care has been taken in compiling the references, errors or omissions cannot be excluded and the EPO disclaims all liability in this regard.*

**Patent documents cited in the description**

- US 5232058 A [0003]
- US 20140251695 A1 [0004]
- US 4813497 A [0004]
- US 20140262530 A1 [0004]
- US 5474334 A [0004]
- US 3743034 A [0005]
- EP 1923534 A1 [0005]
- US 20050098350 A1 [0005]
- US 20110140411 A1 [0006]
- GB 2026063 A [0006]