



US00D779022S

(12) **United States Design Patent** (10) **Patent No.:** **US D779,022 S**  
**Burrow** (45) **Date of Patent:** **\*\* Feb. 14, 2017**

(54) **PROJECTILE APERTURE WICKING PATTERN**

7,441,504 B2 10/2008 Husseini et al.  
7,610,858 B2 11/2009 Chung  
7,750,091 B2 7/2010 Maljkovic et al.

(Continued)

(71) Applicant: **True Velocity, Inc.**, Dallas, TX (US)

(72) Inventor: **Lonnie Burrow**, Carrollton, TX (US)

FOREIGN PATENT DOCUMENTS

(73) Assignee: **TRUE VELOCITY, INC.**, Dallas, TX (US)

CA 2813634 A1 4/2012  
EP 2625486 A1 8/2013

(Continued)

(\*\*) Term: **15 Years**

OTHER PUBLICATIONS

(21) Appl. No.: **29/535,552**

Korean Intellectual Property Office (ISA), International Search Report and Written Opinion for PCT/US2011/062781 dated Nov. 30, 2012, 16 pp.

(22) Filed: **Aug. 7, 2015**

(51) **LOC (10) Cl.** ..... **22-03**

(52) **U.S. Cl.**  
USPC ..... **D22/116**

(58) **Field of Classification Search**  
USPC ..... D22/115-116  
CPC ..... F42B 30/02; F42B 5/02; F42B 5/26;  
F42B 12/34; F42B 8/04; F42B 10/22; F42B 8/14; F41A 9/83; F41A 9/82; F41A 9/01; F41A 9/09; F41A 9/86  
See application file for complete search history.

*Primary Examiner* — Michael A Pratt  
(74) *Attorney, Agent, or Firm* — Chainey P. Singleton; Edwin S. Flores; Chalker Flores, LLP

(57) **CLAIM**

The ornamental design for a projectile aperture wicking pattern, as shown and described.

**DESCRIPTION**

FIG. 1 is an isometric view of a cartridge showing my new design of the wicking pattern in the projectile aperture.  
FIG. 2 is an isometric view of a projectile aperture showing my new design of the wicking pattern in the projectile aperture.  
FIG. 3 is a top view of a cartridge showing my new design of the wicking pattern in the projectile aperture.  
FIG. 4 is a cross sectional view along 4-4 of FIG. 3 showing my new design of the wicking pattern in the projectile aperture; and,  
FIG. 5 is a cross sectional view along 5-5 of FIG. 3 showing my new design of the wicking pattern in the projectile aperture.

(56) **References Cited**

U.S. PATENT DOCUMENTS

3,955,506 A 5/1976 Luther et al.  
4,228,724 A 10/1980 Leich  
4,475,435 A 10/1984 Mantel  
5,950,063 A 9/1999 Hens et al.  
5,961,200 A 10/1999 Friis  
6,004,682 A 12/1999 Rackovan et al.  
6,272,993 B1 8/2001 Cook et al.  
6,460,464 B1 10/2002 Attarwala  
6,845,716 B2 1/2005 Husseini et al.  
7,204,191 B2 4/2007 Wiley et al.  
7,213,519 B2 5/2007 Wiley et al.  
7,392,746 B2 7/2008 Hansen

**1 Claim, 5 Drawing Sheets**



(56)

**References Cited**

U.S. PATENT DOCUMENTS

8,443,730	B2	5/2013	Padgett
8,522,684	B2	9/2013	Davies et al.
8,561,543	B2	10/2013	Burrow
8,573,126	B2	11/2013	Klein et al.
8,763,535	B2	7/2014	Padgett
8,790,455	B2	7/2014	Borissov et al.
8,807,008	B2	8/2014	Padgett et al.
8,813,650	B2	8/2014	Maljkovic et al.
D715,888	S	10/2014	Padgett
8,869,702	B2	10/2014	Padgett
8,875,633	B2	11/2014	Padgett
8,978,559	B2	3/2015	Davies et al.
9,091,516	B2	7/2015	Davies et al.
2001/0013299	A1	8/2001	Husseini et al.
2003/0217665	A1	11/2003	Rennard
2005/0005807	A1	1/2005	Wiley
2005/0056183	A1	3/2005	Meshirer
2010/0016518	A1	1/2010	El-Hibri et al.
2010/0300319	A1	12/2010	Guindon
2010/0305261	A1	12/2010	Maljkovic et al.
2012/0024183	A1	2/2012	Klein

2012/0180687	A1	7/2012	Padgett et al.
2013/0180392	A1	7/2013	Nuetzman et al.
2014/0060372	A1	3/2014	Padgett
2014/0060373	A1	3/2014	Maljkovic et al.
2014/0076188	A1	3/2014	Maljkovic et al.
2014/0216293	A1	8/2014	Klein et al.
2014/0235784	A1	8/2014	Maljkovic et al.
2014/0260925	A1	9/2014	Beach et al.
2014/0373744	A1	12/2014	Padgett
2016/0003594	A1*	1/2016	Burrow ..... F42B 5/307 86/10
2016/0003597	A1*	1/2016	Burrow ..... F42B 5/307 86/18
2016/0033241	A1*	2/2016	Burrow ..... F42B 5/307 102/466

FOREIGN PATENT DOCUMENTS

WO	2012047615	A1	4/2012
WO	2012097317	A2	7/2012
WO	2012097320	A1	7/2012
WO	2013070250	A1	5/2013
WO	2014062256	A2	4/2014

\* cited by examiner

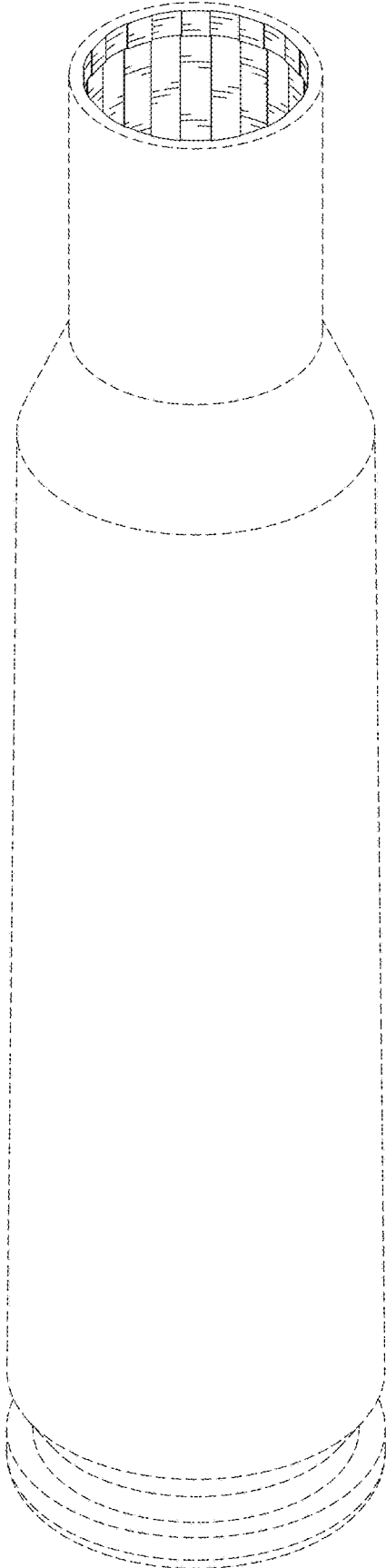

FIG. 1

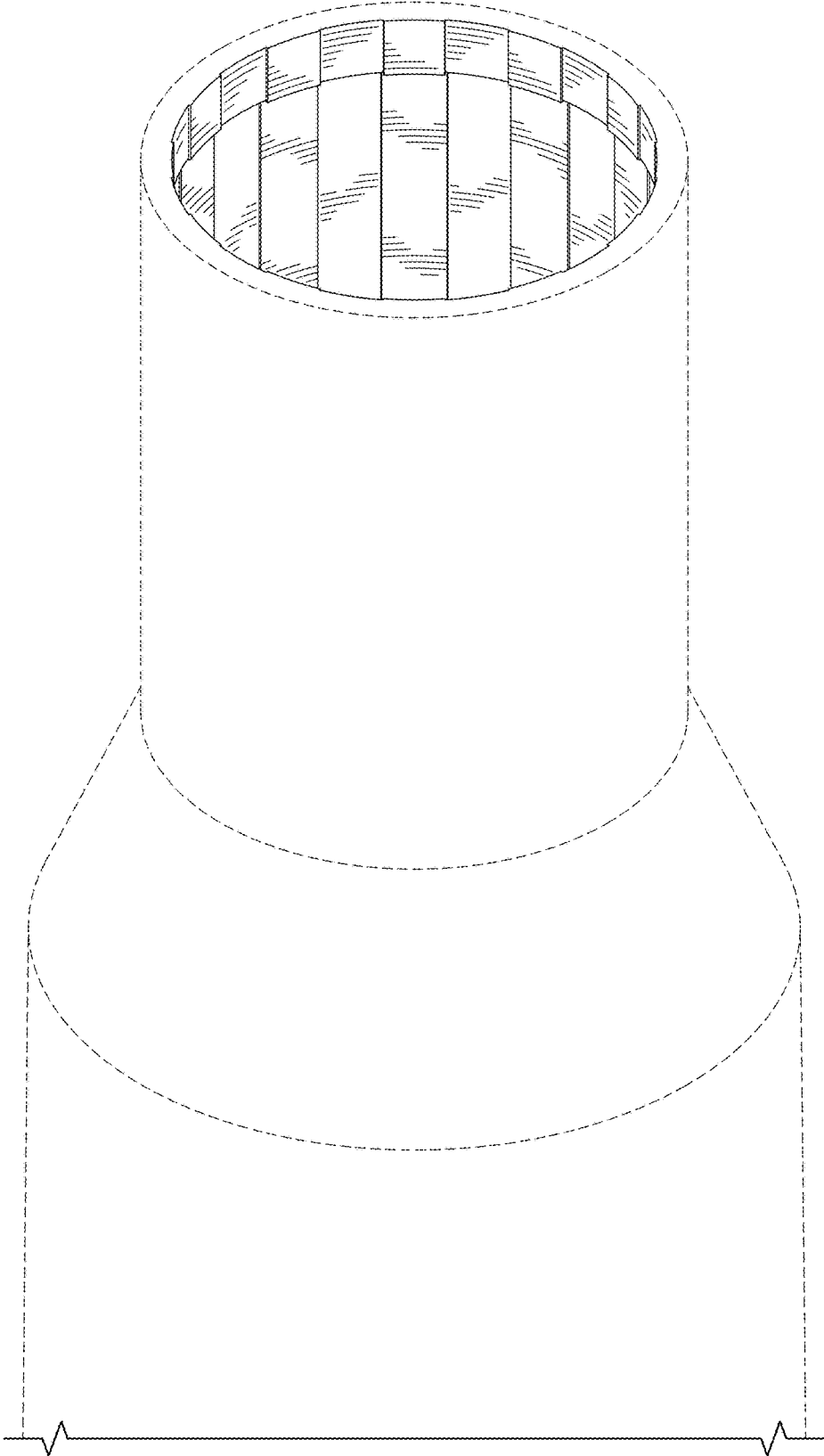

FIG. 2

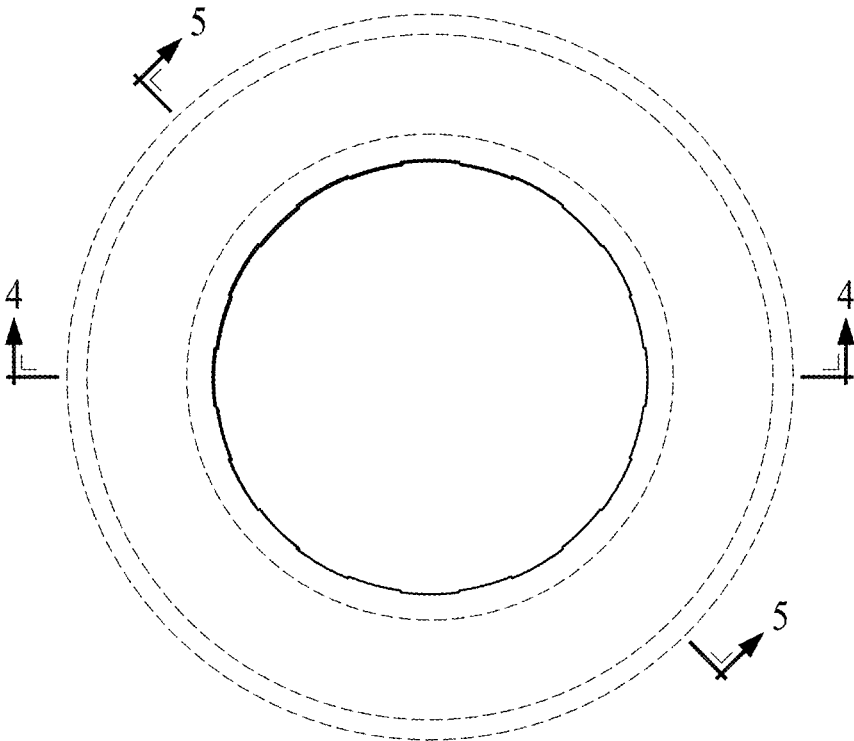

FIG. 3

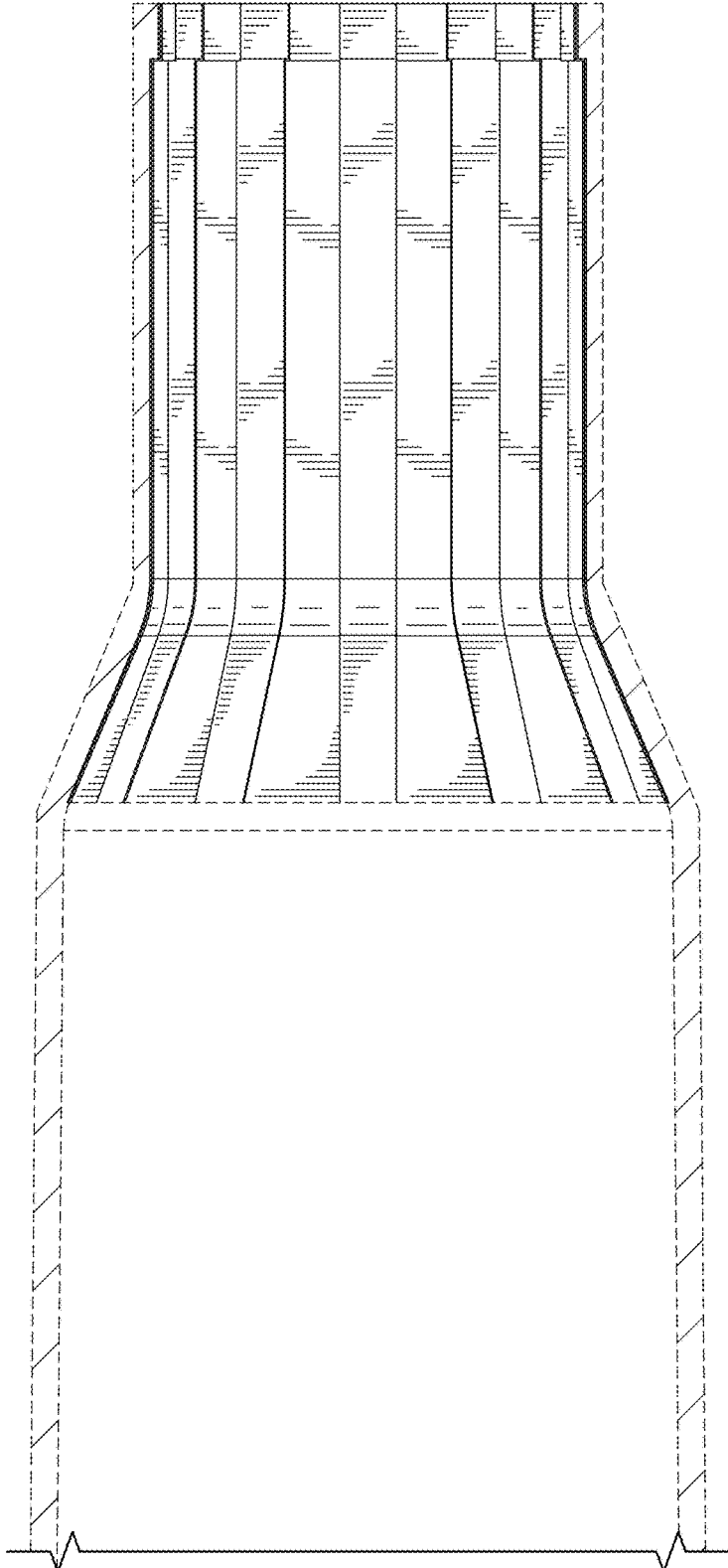

FIG. 4

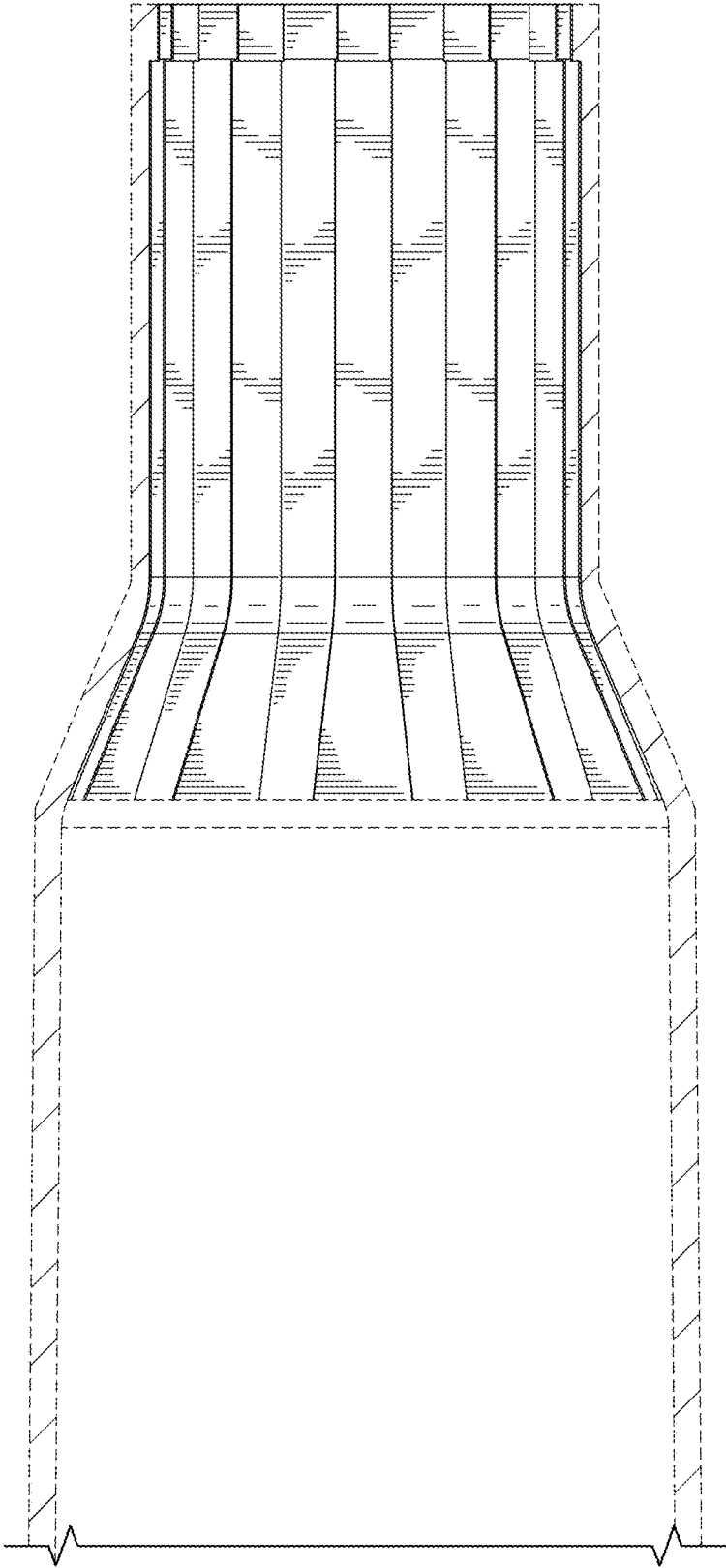

FIG. 5