

(No Model.)

R. G. ROLAND.

DOOR LOCK.

No. 316,574.

Patented Apr. 28, 1885.

Fig. 1.

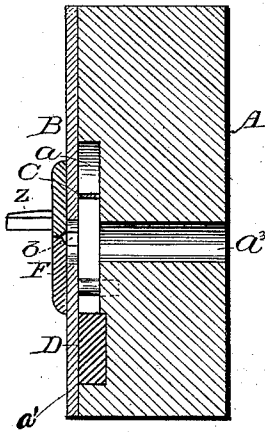

Fig. 2.

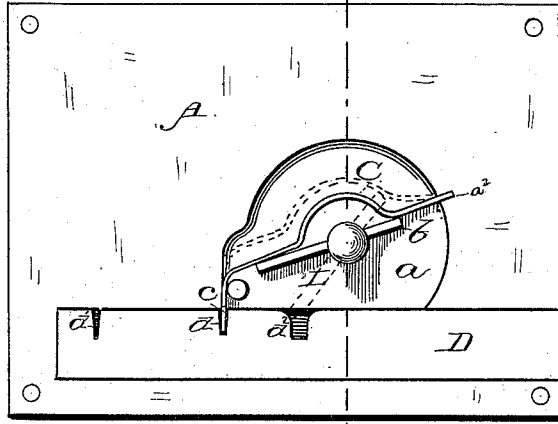

Fig. 5.

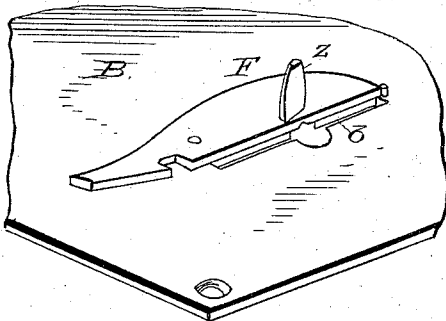

Fig. 3.

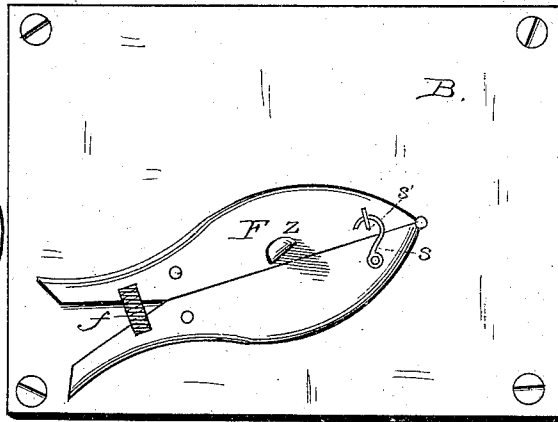

Fig. 4.



WITNESSES:

*J. M. Reynolds*  
*A. Clay Smith*

INVENTOR  
Robert G. Roland

BY

*A. C. Jenkins*  
 ATTORNEY

# UNITED STATES PATENT OFFICE.

ROBERT G. ROLAND, OF BEECH GROVE, KENTUCKY.

## DOOR-LOCK.

SPECIFICATION forming part of Letters Patent No. 316,574, dated April 28, 1885.

Application filed July 31, 1884. (No model.)

*To all whom it may concern:*

Be it known that I, ROBERT G. ROLAND, a citizen of the United States, residing at Beech Grove, in the county of McLean and State of Kentucky, have invented certain new and useful Improvements in Door-Locks; and I do declare the following to be a full, clear, and exact description of the invention, such as will enable others skilled in the art to which it appertains to make and use the same, reference being had to the accompanying drawings, and to the letters and figures of reference marked thereon, which form a part of this specification.

My invention relates to door-locks; and the novelty consists in the construction, arrangement, and adaptation of parts, as will be more fully hereinafter set forth, and specifically pointed out in the claims.

The essential object of the invention is to provide a lock and a peculiar key therefor which shall be inexpensive of construction, simple in operation, not liable to get out of order, and which shall be efficient in preventing evil-disposed persons from tampering with the bolt.

To these ends it consists, essentially, in a body in a recess of which is housed a single bolt. This bolt has two recesses, in which the end of a single spring operates to lock the bolt either in a projected position into engagement with the keeper or in its withdrawn position within the lock. The key is cylindrical and carries a pivoted arm which operates the bolt. The arm is pressed within the shank of the key when the key is inserted into the lock, and a spring operates to throw the arm outward. The back plate of the lock has a slot through which the key-arm passes, and as the key is partly withdrawn this key-arm falls into position to operate the bolt and the bolt-spring. Spring-shields pivoted upon the outer face of the back plate serve to close the key-hole, except when they are forced apart by the sharpened point of the key, and a hook serves to lock these together when it is desired to lock the door upon the inside. When it is desired to remove the key, the said key is forced inward until the arm passes entirely through the back plate, when a quarter-turn

of the key will bring the said arm against a lug or guard and within the plane of the key, and the key may be readily withdrawn.

The invention is illustrated in the accompanying drawings, which form a part of this specification, and in which—

Figure 1 is a cross-section of the lock through the line *x x*, Fig. 2. Fig. 2 is a plan view thereof with the back plate removed. Fig. 3 is a back plan view with the back plate in position. Fig. 4 is a detail view of the key, and Fig. 5 a detail view of the key-closing guard.

Referring to the drawings, in which similar letters of reference indicate like parts in all the figures, A designates the body of the lock, to which is secured a back plate, B, and between which is formed and located the spring-recess *a* and the boltway *a'*. One end of the spring C has a bearing in slit *a''* of the body, and the opposite end, *c*, operates in a recess, *d'*, of the bolt D to lock the said bolt into engagement with the keeper, (not shown,) or into the recess *d*, to lock said bolt in its withdrawn position.

The key-hole of the lock is designated by the letter *a''*, and it is continuous through the body and back plate, B.

Pivoted to the outer face of the back plate, B, is a pair of guards, F, a spring, *f*, operating to hold them together with their contiguous edges over the plane of the key-hole, and a slot, *b*, in the plate B extends upon either side of the key-hole in that portion.

K designates the shank of the key, which is circular in cross-section, and has a sharpened or conical point, *k*. In a longitudinal slot in the said shank is pivoted an arm, L, in such a manner as to present a long end, *l'*, and a short end, *l*. A spring, M, is located within the slot and serves by its spring force to throw the longer end of the arm toward the point of the key after said end has been pulled back preparatory to inserting the key in the lock.

Upon the guards F are secured a hook, *s*, and an eye, *s'*, by means of which the said guards may be secured together, and this action, it will be observed, serves to lock the entire device against the action of the key.

Upon one of the guards F contiguous to the

key-hole is a lug, *z*, the said lug serving as a means for throwing the arm L within the plane of the key to allow the said key to be withdrawn.

5 The normal condition of the lock for purposes of this description will be assumed to be with the guards close together, but not locked, with the bolt withdrawn, and with the longer end of the arm L in the direction of the point  
10 of the key-shank. The operator pulls the longer end, *l'*, of the arm L back against the action of the spring M and inserts the key into the hole *a*<sup>3</sup>, forcing it entirely through the back plate, B. As soon as the arm L is clear  
15 of the back plate the action of the spring M throws the longer end outward. The key being then partially withdrawn said arm bears against the guards F and is forced to assume a position at right angles to the plane of the  
20 key-shank and parallel with the plane of the back plate. A slight oscillation of the key will then make the arm L register with the slot *b*, and the key being further withdrawn the said arm drops into the chamber *a* with  
25 the longer end lying in the direction of the bolt D and the shorter end lying in the direction of the spring C. As thus conditioned, the key being turned in the proper direction, the first action is that of the short end, *l*, of the  
30 arm against the spring C to unlock the end *c* from the recess *d* of the bolt. As soon as this disengagement has been effected the longer end, *l'*, of said arm engages the recess *d'* of the bolt, and the bolt is forced outward into en-  
35 gagement with the keeper.

To take the key from the lock, force the key inward until the arm L has passed beyond the back plate, B, turn the key until the short end, *l*, comes into contact with the lug *z*, when a  
40 proper manipulation will bring the arm L within the plane of the key and it may readily be withdrawn.

I attach importance to the construction and operation of the key in its relation to the single bolt and single spring. I also attach im-  
45 portance to the guards and their concomitant parts, and to the lug *z* for withdrawing the arm within the body of the key.

Modifications in details of construction may be made without departing from the principle or sacrificing the advantages of my invention, the essential features of which will be readily understood from the foregoing description, taken in connection with the drawings. 50

The lug *z* may be formed with an inclined face, the contact of which with the arm L will serve to force it within the slot of the key. 55

Having thus described the invention, what I claim as new, and desire to secure by Letters Patent of the United States, is— 60

1. The combination, with a lock-case, as described, and with a bolt, D, having recesses *d* and *d'* and spring C, of a key having a pivoted spring-actuated arm, L, having a short end, *l*, adapted to first unlock the spring from the bolt, and a longer end, *l'*, adapted to operate the bolt by the same movement of the key, as set forth. 65

2. The combination of the bolt and spring and the guards F, having spring *f* and lug *z*, with inclined face secured upon one of said guards, with the key having conical point and pivoted and spring-actuated arm L, as and for the purposes set forth. 70

3. The combination, with the body A, having recesses *a* *a'* *a''*, the plate B, having slot *b*, the guards F, spring *f*, and lug *z*, the bolt D, and spring C, of the key having conical point and the pivoted and spring-actuated arm L, as set forth. 75

4. The combination, with a lock-case having a cylindrical key-hole and a slot, *b*, in the back plate, of a key having a slotted cylindrical shank and a pivoted spring-actuated arm, L, a bolt, D, and spring C, and a lug, *z*, lying adjacent to the slot *b*, the whole adapted to serve as and for the purposes set forth. 80

In testimony whereof I affix my signature in presence of two witnesses.

ROBERT G. ROLAND.

Witnesses:

W. L. CRANDELL,  
M. G. ASHBY.