

(12) PATENT
(19) AUSTRALIAN PATENT OFFICE

(11) Application No. AU 200065501 B2
(10) Patent No. 771847

(54) Title
Gaming machine with buy feature games

(51)⁷ International Patent Classification(s)
G06F 019/00 A63F 013/00
A63F 005/04 G07F 017/34

(21) Application No: **200065501**

(22) Application Date: **2000.08.23**

(87) WIPO No: **WO01/15055**

(30) Priority Data

(31) Number	(32) Date	(33) Country
PQ 2428	1999.08.25	AU

(43) Publication Date : **2001.03.19**

(43) Publication Journal Date : **2001.05.24**

(44) Accepted Journal Date : **2004.04.01**

(71) Applicant(s)
Aristocrat Technologies Australia Pty Ltd

(72) Inventor(s)
Natalie Bryant; Nicholas Luke Bennett

(74) Agent/Attorney
F B Rice and Co,605 Darling Street,BALMAIN NSW 2041

(56) Related Art
US 6113492
CA 2199826
US 5704835

65501/00

(12) INTERNATIONAL APPLICATION PUBLISHED UNDER THE PATENT COOPERATION TREATY (PCT)

(19) World Intellectual Property Organization
International Bureau(43) International Publication Date
1 March 2001 (01.03.2001)

PCT

(10) International Publication Number
WO 01/15055 A1

- (51) International Patent Classification⁷: G06F 19/00 // 161:00, A63F 5/04, 13/00, G07F 17/34
- (21) International Application Number: PCT/AU00/00997
- (22) International Filing Date: 23 August 2000 (23.08.2000)
- (25) Filing Language: English
- (26) Publication Language: English
- (30) Priority Data: PQ 2428 25 August 1999 (25.08.1999) AU
- (71) Applicant (for all designated States except US): ARIS-TOCRAT TECHNOLOGIES AUSTRALIA PTY LTD [AU/AU]; 71 Longueville Road, Lane Cove, NSW 2066 (AU).
- (72) Inventors; and
- (75) Inventors/Applicants (for US only): BRYANT, Natalie [AU/AU]; 71 Longueville Road, Lane Cove, NSW 2066 (AU). BENNETT, Nicholas, Luke [AU/AU]; 71 Longueville Road, Lane Cove, NSW 2066 (AU).
- (74) Agent: F B RICE & CO; 605 Darling Street, Balmain, NSW 2041 (AU).
- (81) Designated States (national): AU, JP, NZ, US, ZA.
- Published:
— With international search report.
- For two-letter codes and other abbreviations, refer to the "Guidance Notes on Codes and Abbreviations" appearing at the beginning of each regular issue of the PCT Gazette.

(54) Title: GAMING MACHINE WITH BUY FEATURE GAMES

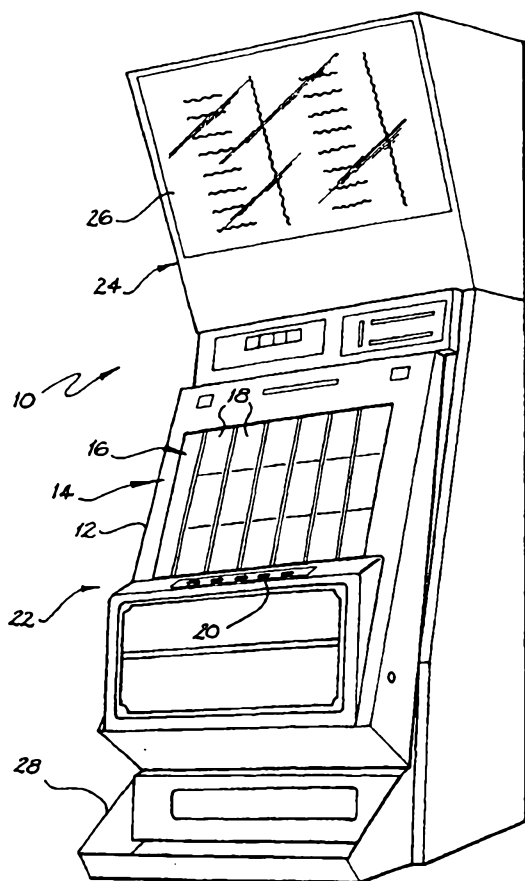

(57) Abstract: A gaming machine (10) includes a display (14). The display (14) includes a plurality of display positions (18) for displaying combinations of symbols. A controller controls operation of the machine. The controller includes a processor for processing data and displaying selected data on the display (14). A selecting arrangement (20) is operable by the player of the machine (10) for enabling the player to select at least one feature which can be added to a base game played on the machine (10).

WO 01/15055 A1

WO 01/15055

PCT/AU00/00997

Gaming machine with buy feature games

Field of the Invention

5 The present invention relates to a gaming machine. More particularly,
the invention relates to a gaming machine of the type known as a slot
machine or a fruit machine. Certain types of these machines have a series of
rotatable reels, each of which displays a series of symbols or a video
simulation of such a mechanism while other types of machines are arranged
to play video simulations of card games or other types of wagering games,
10 such as bingo or keno. The invention has particular application to an
improved game played on such a machine.

Background to the Invention

15 Players regularly playing gaming machines need to have their interests
maintained. Therefore, it is necessary for manufacturers of these machines
to develop inventive game features which add interest to the games provided
on such machines in order to keep the players entertained and willing to
continue to play the games.

20 There is a continuous trade-off between what the players of the
machines want and what the operators of the machines want from the
machines. Naturally, operators want the players to stake more money per
game so that the overall turnover is higher. Conversely, players will not do
this unless they feel that they are getting more for the extra money that they
are betting.

25 Further, as the range of machines and games increases, it is becoming
increasingly important to offer more options to the players. The more
options that are available in one machine, the easier it is to maintain the
player's interest and the easier it is for players to be able to gain access to a
machine that will offer them exactly the game that they want.

30 To date, most types of video gaming machines which are available to
players offer limited options. At best, a range of bet sizes and paylines upon
which the players can bet are offered. Certain machines also offer a double-
up option available after a win while other machines have various ranges of
paytables particularly for higher bets.

35

Summary of the Invention

According to a first aspect of the invention there is provided a gaming machine which includes:

a display means including a plurality of display positions for displaying
5 combinations of symbols;

a control means for controlling operation of the machine, the control means including a processing means for processing data and displaying selected data on the display means; and

a selecting means operable by a player of the machine for enabling the player to
10 select at least one feature which can be added to a base game played on the machine, an additional wager being staked by the player in order to be eligible for said at least one feature, there being no guarantee that a benefit provided by the feature will eventuate merely by having staked the additional wager.

In this aspect of the invention, only one additional feature or a range of the same
15 type of feature may be offered and the additional wager staked by the player may be a multiple of a base bet wagered by the player. Different multiples of the base bet may purchase different features of that type. For example, a bet X2 feature may purchase two free spins, a bet X3 feature may purchase four free spins and bet X4 feature may purchase six free spins.

20 According to a second aspect of the invention, there is provided a gaming machine which includes

a display means including a plurality of display positions for displaying combinations of symbols;

a control means for controlling operation of the machine, the control means
25 including a processing means for processing data and displaying selected data on the display means; and

a selecting means operable by a player of the machine for enabling the player to
30 select at least one feature which can be added to a base game played on the machine, an additional wager staked by the player in order to be eligible for said at least one feature being a fixed amount multiplied by a bet wagered per line (for a spinning reel game) or per draw (for a card game) there being no guarantee that a benefit provided by the feature will eventuate merely by having staked the additional wager.

The base game may have no features at all. For example, in the case of a video
35 simulation of a spinning reel game, there would be no scatter symbol or substitute symbol or feature triggered by the occurrence of a predetermined or random event. Instead, by means of the selecting means, the player may be able to select at least one

and, preferably, a range of features that can be added to the base game to tailor the base game to the player's requirements. Various features may be offered. For example, certain symbols may be selected to pay as scatter symbols or substitute symbols as well as or in addition to the standard pays. Other examples include additional types of pays, for example, right to left as well as the basic left to right pay or bonus features such as free games, bonus pays, etc which are triggered by certain combinations.

Certain features may be offered as no-cost features which are selected by the player by means of the selecting means with certain of the other features requiring the staking of an additional wager or bet. If desired, the bet to obtain one or more features may be independent of the type or size of bet made on the base game. Thus, it is not necessary for the maximum bet to be placed on the base game before access can be gained to the range of features. In addition, the cost for the various features may differ depending on the type of feature or range of features selected.

The selecting means may include a plurality of selectors, such as buttons on the midtrim, operable by the player to select the feature required before making the base bet. One of the buttons may be used by the player when only the base bet is to be staked.

Only one feature, if any, at a time may be selectable by the player by means of the selectors. For example, a standard bet with no additional feature may be wagered, or a bet with only one type of feature may be wagered.

As there is no guarantee that the feature will eventuate merely by having staked the additional wager, the player will not necessarily see a direct result of the extra stake for every game played. For example, a predetermined combination may need to appear to trigger the special feature (eg. free spins) or to pay a bonus prize (eg a right to left pay).

The feature for which the additional wager is staked may be triggered independently of the base game. In other words, a random selection is made by the control means as to whether or not to trigger the feature completely independently of the base game.

Further, the gaming machine may be a multi-game machine having various games. Then, the appropriate game may initially be chosen and, thereafter, the required feature or features for the game may be selected by the player.

The selecting means may include dedicated keys or buttons on a keypad of the gaming machine and/or a touch or interactive screen of the display mean for enabling the features and/or games to be selected.

According to a third aspect of the invention, there is provided a gaming machine which includes

a display means including a plurality of display positions for displaying combinations of symbols;

5 a control means for controlling operation of the machine, the control means including a processing means for processing data and displaying selected data on the display means; and

a selecting means, including a plurality of selectors operable by a player of the machine for enabling the player prior to making a base bet, for selecting a range of
10 features to be added to the base game played on the machine to enable the player to tailor the game to the player's requirements, there being no guarantee that a benefit provided by any of the selected features will eventuate merely by having made the selection.



Brief Description of Drawings

The invention is now described by way of example with reference to the accompanying diagrammatic drawings in which:

Figure 1 shows a three dimensional view a gaming machine;

5 Figure 2 shows a block diagram of a control means of the gaming machine;

Figure 3 shows a schematic plan representation of one embodiment of a keypad of the gaming machine;

10 Figure 4 shows a schematic representation of a first screen of the gaming machine;

Figure 5 shows a schematic representation of a second screen of the gaming machine;

Figure 6 shows a schematic representation of one embodiment of a third screen of the gaming machine;

15 Figure 7 shows a schematic representation of another embodiment of the third screen of the gaming machine; and

Figure 8 shows a schematic plan representation of another embodiment of a keypad of the gaming machine; and

20 Figure 9 shows a flow chart of the operation of the embodiment of the invention described with reference to Figure 8.

Detailed description of the Drawings

In Figure 1, reference numeral 10 generally designates a gaming machine, including a game, in accordance with the invention. The machine 25 10 includes a gaming console 12 having a video display unit 14. The video display unit includes a screen 16 on which reels 18 are simulated. A keypad 20, which is shown in greater detail in Figure 3 of the drawings, is mounted on a midtrim 22 of the machine 10.

The machine includes a topbox 24 on which a paytable 26 is arranged.

30 Referring now to Figure 2 of the drawings, a control means 30 of the machine 10 is illustrated. A program which implements the game and user interface is run on a processor 32 of the control means 30. The processor 32 forms part of a controller 34 which drives the screen 16 of the video display unit 14. The processor 32 receives input signals from a first group of sensors 35 36.1 which are responsive to keys of the keypad 20. A second group of

WO 01/15055

PCT/AU00/00997

5

sensors 36.2 are touch sensors associated with the screen 16 of the video display unit 14.

The controller 34 also receives input pulses from a mechanism 38 indicating that a player has provided sufficient credit to begin playing. The mechanism 38 may be a coin input chute, a bill collector, a credit card reader, any other type of validation device, or a combination thereof.

The controller 34 also controls a payout mechanism 40 which, for example, may be a coin hopper for feeding coins to a coin tray 28 of the machine 10.

With the game of the gaming machine 10, a player playing the machine 10 has the option to make a bet that is a multiple of a base bet to buy an additional feature to the game. The additional bet need not be a multiple of the specified maximum bet of the machine 10. Thus, the player is allowed to, for example, double or treble their initial bet to be eligible for an additional game feature. In this way, even players who bet a single credit on one line (on a multi-line game), are eligible to buy features, by doubling or trebling their bets.

The extra bet that the player is required to make does not make any change to the game the player has bought other than to introduce eligibility to the feature. In other words, no additional pay lines are bought or linear increases made to the pay table as the extra bet is a dedicated bet towards the feature.

Referring now to Figure 3 of the drawings a modified keypad 20 for the machine is shown. Instead of, or in addition, to the touch screen facility in the screen 16 of the video display unit 14 of the machine 10, dedicated buttons 64 are provided on the keypad 20.

The keypad 20 has a conventional array of buttons 66 for enabling the player to select the number of lines of the machine on which to achieve a payout as well as a conventional array of buttons 68 for enabling the player to select the number of credits to be bet per line.

A "base bet" is represented by the buttons 68 labelled "Bet x credits per line" and the buttons 66 labelled "Play x lines". The feature of the game is that if a player stakes double the base bet by means of button 64.1 then, whenever a specified combination of symbols is spun up, certain reel positions will be held while the rest of the reels are spun again twice for free. For triple the base bet (button 64.2) the same combination would result in

WO 01/15055

PCT/AU00/00997

6

four free spins and for quadruple the base bet (button 64.3) there would be six free spins. Thus, if the player is betting two credits per line on five lines then the base bet will be ten credits. If the player chooses to buy access to the four free spins feature by selecting the "four feature spins (bet x 3)"
5 button 64.2 then a game will cost the player thirty credits. The payline prizes will still only be multiplied by the player's bet per line of two credits, and prize combinations will still only apply on the five lines that have been bought. However, the additional feature of a specified combination of symbols awarding four re-spins of some of the reels will apply. Accordingly,
10 it will be noted that only the base bet or the base bet plus the additional credit for one type of feature may be wagered at any one time. Also, the mere wagering of the additional credit does not guarantee that the feature will occur. The wagering of the additional credit only provides eligibility for the applicable feature.

15 It will be appreciated that various other options could be provided by means of the appropriate number of buttons 64 on the keypad 20.

In this embodiment, other examples which are possible are, inter alia, the additional feature may be the purchase of a certain combination which, if obtained, will commence a free game series. Instead, an additional feature
20 trigger symbol may be purchased so that, in addition to an original trigger symbol, the additional trigger symbol also provides a free spin feature. Yet further, a right-to-left payout feature, in addition to the more conventional left-to-right payout can be bought.

To ensure versatility, the player may be given a choice of which
25 features the player wishes to buy. Then, various icons are displayed on the screen as will now be described with reference to Figures 4 to 7 of the drawings. In Figure 4, a basic game screen is shown and is designated generally by the reference numeral 50. The game screen has the usual reels 18 and multi-line pays as indicated by the arrows 52. If the player touches
30 the icon "Prizes" as indicated at 54, a screen 56 shown in Figure 5 of the drawings is displayed to show what prizes are available to the player. By touching the icon 58 entitled "Features" either a screen 60 as shown in Figure 6 of the drawings or a screen 62 as shown in Figure 7 of the drawings is displayed. The screens 60 and 62 are similar with the difference between the
35 screens being that, in the case of the screen illustrated in Figure 7 of the

WO 01/15055

PCT/AU00/00997

7

drawings, the bet to be made by the player is independent of the type of feature altogether.

5 The screen in Figure 6 or 7 allows the players to select the features required. The various icons illustrated as representations of the screens in Figures 6 and 7 are largely self explanatory. Suffice to say that a player can select various available options to construct their own games at a cost which that player can afford. The cost may be relative to an aspect of the base bet, ie the bet made for the basic game, or independent of the base bet. In addition, the player may be able to nominate the amount they wish to pay for eligibility to a particular feature.

10 In addition, in this embodiment, various features may be offered by the machine 10 such as, for example, certain combinations of a particular symbol triggering a bonus mode where for the next 10 games each symbol of another type that appears pays a bonus. As a further example, a bought feature could be that a particular symbol acts as a substitute symbol for all other symbols or pays for scattered combinations instead of just on a pay line. Hence, it will be appreciated that a large number of features could be built into the machine 10 to be offered to the players. By the player increasing his or her initial bet, eligibility to the feature is gained.

20 Referring now to Figure 8 of the drawings, a keypad 20 in accordance with another embodiment of the invention is illustrated. With reference to Figure 3 of the drawings, like reference numerals refer to like parts, unless otherwise specified.

25 In this embodiment of the invention, instead of the buttons 64, a selection button 70 is provided.

In this embodiment of the invention, the player is required to make a special bet in order to be eligible for the feature. The feature, in this embodiment is the applicant's Mr Cashman. Mr Cashman is a trademark of the applicant and is described in detail in our co-pending PCT Application Number PCT/AU99/01059 dated 26 November 1999 and entitled "Player information delivery". The contents of PCT/AU99/01059 are specifically incorporated herein by reference. The selection of the Mr Cashman feature is by way of the selection button 70. If the player chooses not to play the Mr Cashman feature, then bets are made in the standard way using the standard buttons 66 and 68.

WO 01/15055

PCT/AU00/00997

8

The Mr Cashman feature is, as illustrated, restricted to the maximum number of lines available for the game configuration. Thus, in the example illustrated, the Mr Cashman feature is provided when the player selects that feature and also elects to play the maximum number of lines being 20 lines. By selecting the feature using the button 70, the player will be eligible to enter the Mr Cashman feature for that game.

The extra cost involved for eligibility to the Mr Cashman feature will be five credits multiplied by the number of credits bet per line. Hence, in the illustrated example, the player must stake 25 credits multiplied by the bet per line in order to be eligible for the Mr. Cashman feature. Once again, the mere wagering of the additional credit does not guarantee that the feature will occur but only that the player is eligible for the feature. The Mr. Cashman feature is not triggered by any trigger condition in the base game. Rather, a random selection is made by the controller 34 completely independently of the base game to determine whether the Mr. Cashman feature is to be triggered or not.

In other words, the player first makes a bet per line using the button 68 and then selects the number of lines to be played using buttons 66 or, where the player desires to include the Mr Cashman feature, the player activates the button 70.

Then, for each game played with the extra feature, the player will have a predetermined probability of triggering the Mr Cashman feature to commence after the base game has been completed.

Accordingly, by means of the invention a more versatile gaming machine 10 is provided which provides players with a greater number of options. In so doing, it is believed that the machines 10 will become more attractive to players.

It will be appreciated by persons skilled in the art that numerous variations and/or modifications may be made to the invention as shown in the specific embodiments without departing from the spirit or scope of the invention as broadly described. The present embodiments are, therefore, to be considered in all respects as illustrative and not restrictive.

EDITORIAL NOTE

APPLICATION NUMBER - 65501/00

This specification does not contain a page 9.

CLAIMS:

1. A gaming machine which includes
a display means including a plurality of display positions for displaying combinations of symbols;
- 5 a control means for controlling operation of the machine, the control means including a processing means for processing data and displaying selected data on the display means; and
a selecting means operable by a player of the machine for enabling the player to select at least one feature which can be added to a base game played on the machine, an
10 additional wager being staked by the player in order to be eligible for said at least one feature, there being no guarantee that a benefit provided by the feature will eventuate merely by having staked the additional wager.
2. The gaming machine of claim 1 in which the additional wager staked by the player is a multiple of a base bet wagered by the player.
- 15 3. The gaming machine of claim 2 in which different multiples of the base bet purchase different features.
4. The gaming machine of any one of the preceding claims in which the selecting means includes a plurality of selectors operable by the player to select said at least one feature before making the base bet.
- 20 5. The gaming machine of any one of the preceding claims in which the feature is triggered independently of the base game.
6. The gaming machine of any one of the preceding claims in which the selecting means enables a player to select a range of features to enable the player to tailor the game to the player's requirements.
- 25 7. The gaming machine of claim 6 in which certain of the features are no-cost features while other features require the staking of an additional wager by the player.
8. The gaming machine of any one of the preceding claims which is a multi-game machine having various games, the selecting means being used by the player to select one of the games as the base game.
- 30 9. The gaming machine of any one of the preceding claims in which the selecting means includes dedicated buttons on a keypad of the control means.
10. The gaming machine of any one of the preceding claims in which the selecting means includes touch sensors of a touch screen of a display means.
11. A gaming machine which includes
35 a display means including a plurality of display positions for displaying combinations of symbols;

a control means for controlling operation of the machine, the control means including a processing means for processing data and displaying selected data on the display means; and

5 a selecting means operable by a player of the machine for enabling the player to select at least one feature which can be added to a base game played on the machine, an additional wager staked by the player in order to be eligible for said at least one feature being a fixed amount multiplied by a bet wagered per line or per draw, there being no guarantee that a benefit provided by the feature will eventuate merely by having staked the additional wager.

10 12. The gaming machine of claim 11 in which the selecting means includes a plurality of selectors operable by the player to select the feature required before making a base bet.

13. The gaming machine of claim 11 or claim 12, in which the feature is triggered independently of the base game.

15 14. The gaming machine of any one of claims 11 to 13 inclusive, in which the selecting means enables a player to select a range of features to enable the player to tailor the game to the player's requirements.

15. The gaming machine of claim 14 in which certain of the features are no-cost features while other features require the staking of an additional wager by the player.

20 16. The gaming machine of any one of claims 11 to 15 inclusive, which is a multi-game machine having various games, the selecting means being used by the player to select one of the games as the base game.

17. The gaming machine of any one of claims 11 to 16 inclusive, in which the selecting means includes dedicated buttons on a keypad of the control means.

25 18. The gaming machine of any one of claims 11 to 17 inclusive, in which the selecting means includes touch sensors of a touch screen of a display means.

19. A gaming machine which includes

a display means including a plurality of display positions for displaying combinations of symbols;

30 a control means for controlling operation of the machine, the control means including a processing means for processing data and displaying selected data on the display means; and

35 a selecting means, including a plurality of selectors operable by a player of the machine for enabling the player prior to making a base bet, for selecting a range of features to be added to a base game played on the machine to enable the player to tailor

the game to the player's requirements, there being no guarantee that a benefit provided by any of the selected features will eventuate merely by having made the selection.

20. A gaming machine as claimed in any one of claims 1, 11 and 19 and substantially as described herein with reference to the accompanying drawings.

5

Dated this twenty-third day of January 2004

Aristocrat Technologies Australia Pty Ltd
Patent Attorneys for the Applicant:

10

F B RICE & CO

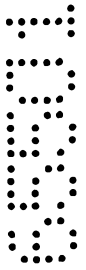

WO 01/15055

PCT/AU00/00997

1 / 9

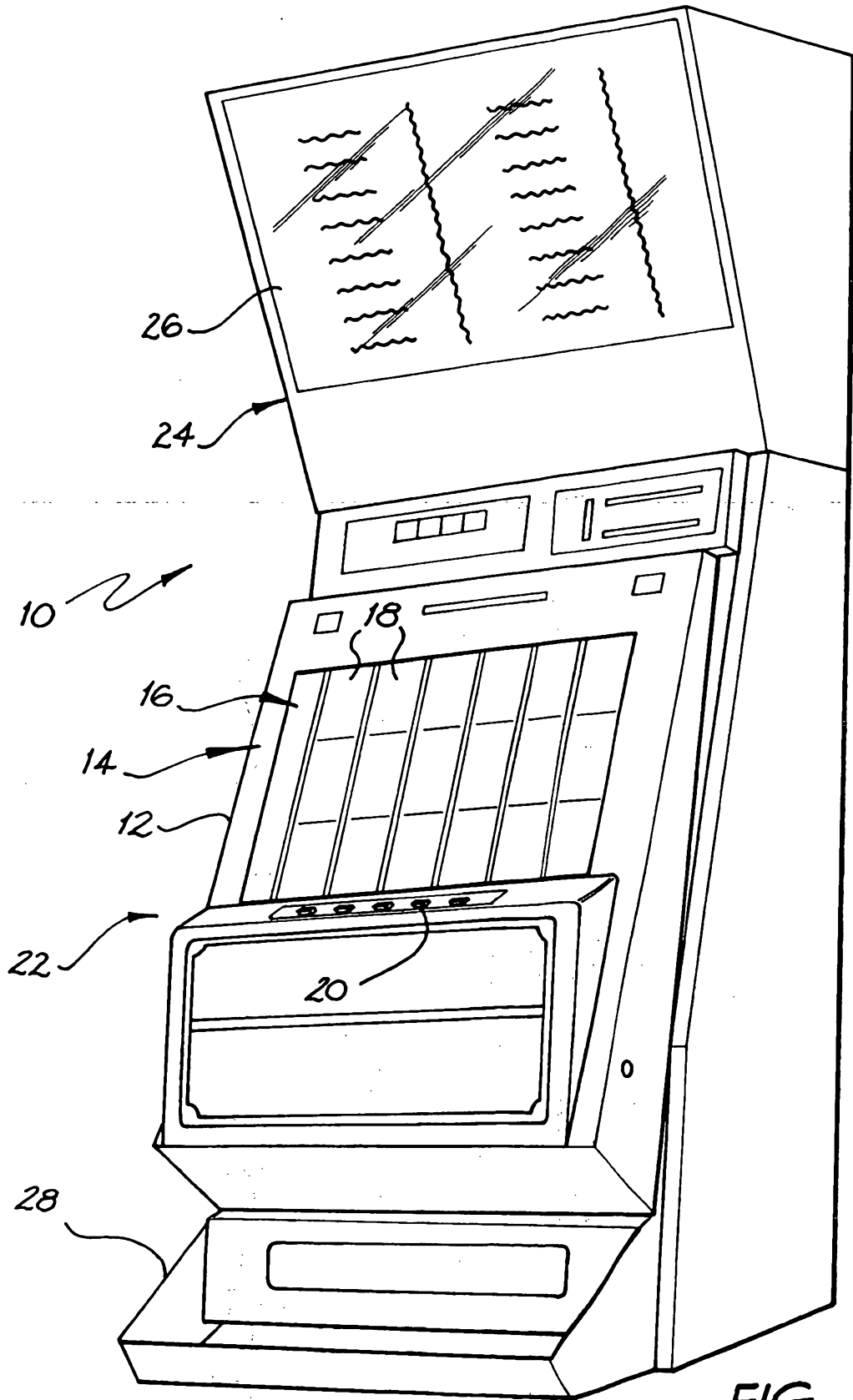

SUBSTITUTE SHEET (RULE 26)
ISA / US

FIG. 1

WO 01/15055

2 / 9

PCT/AU00/00997

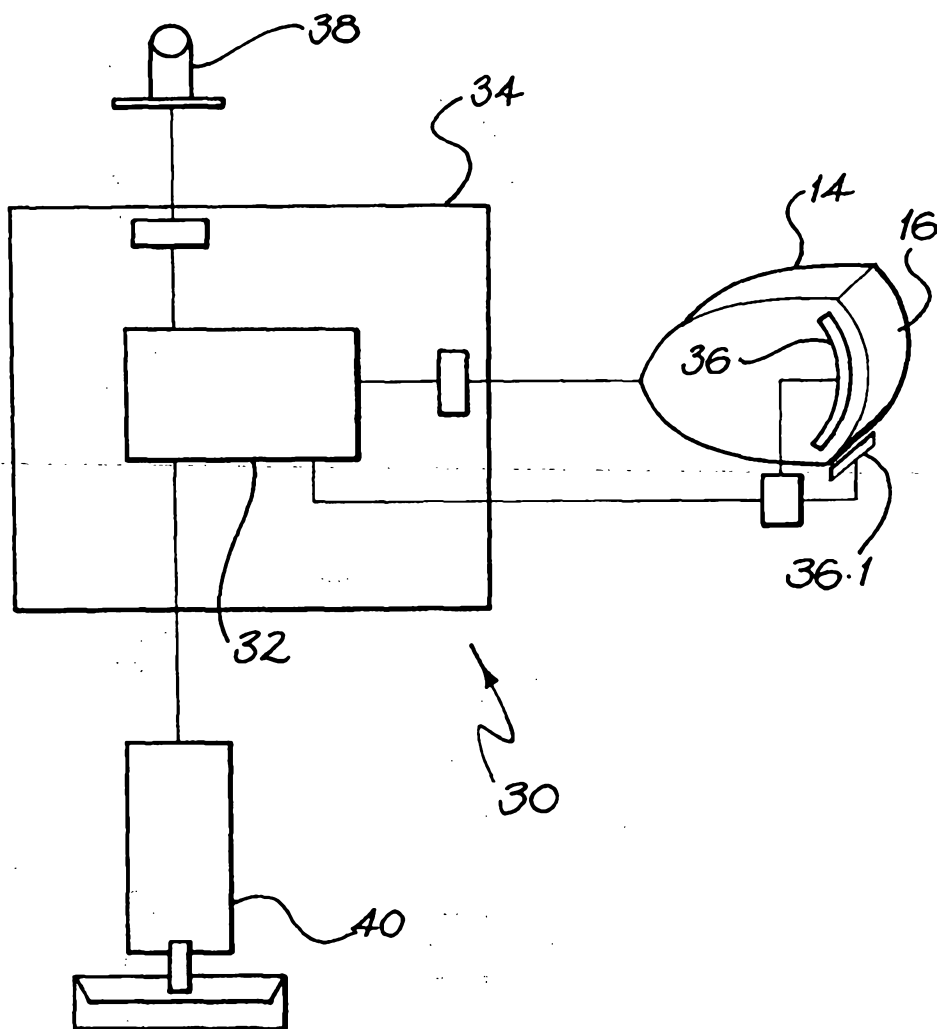
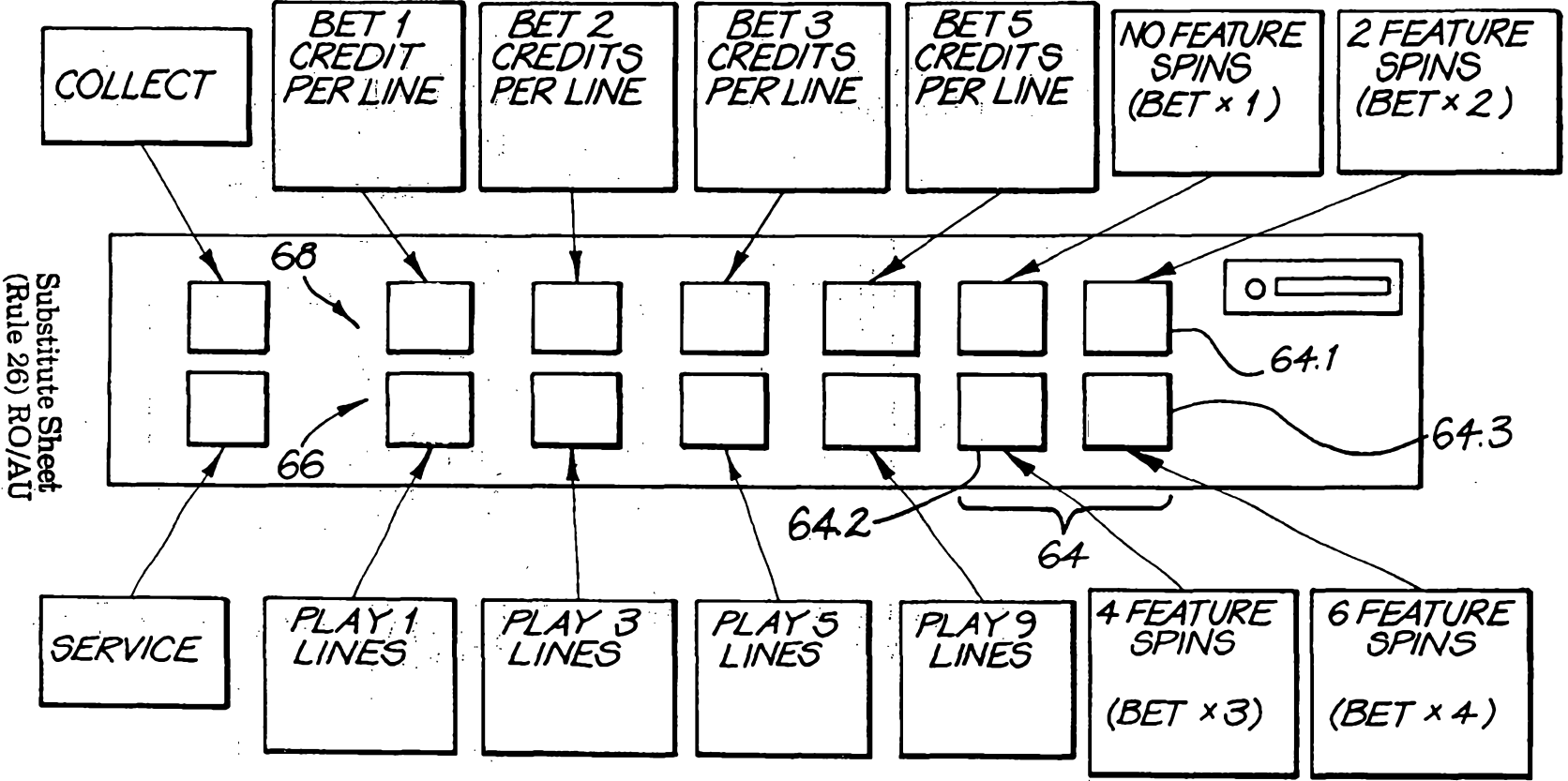

FIG. 2



Substitute Sheet
(Rule 26) RO/AU

FIG. 3

WO 01/15055

4 / 9

PCT/AU00/00997

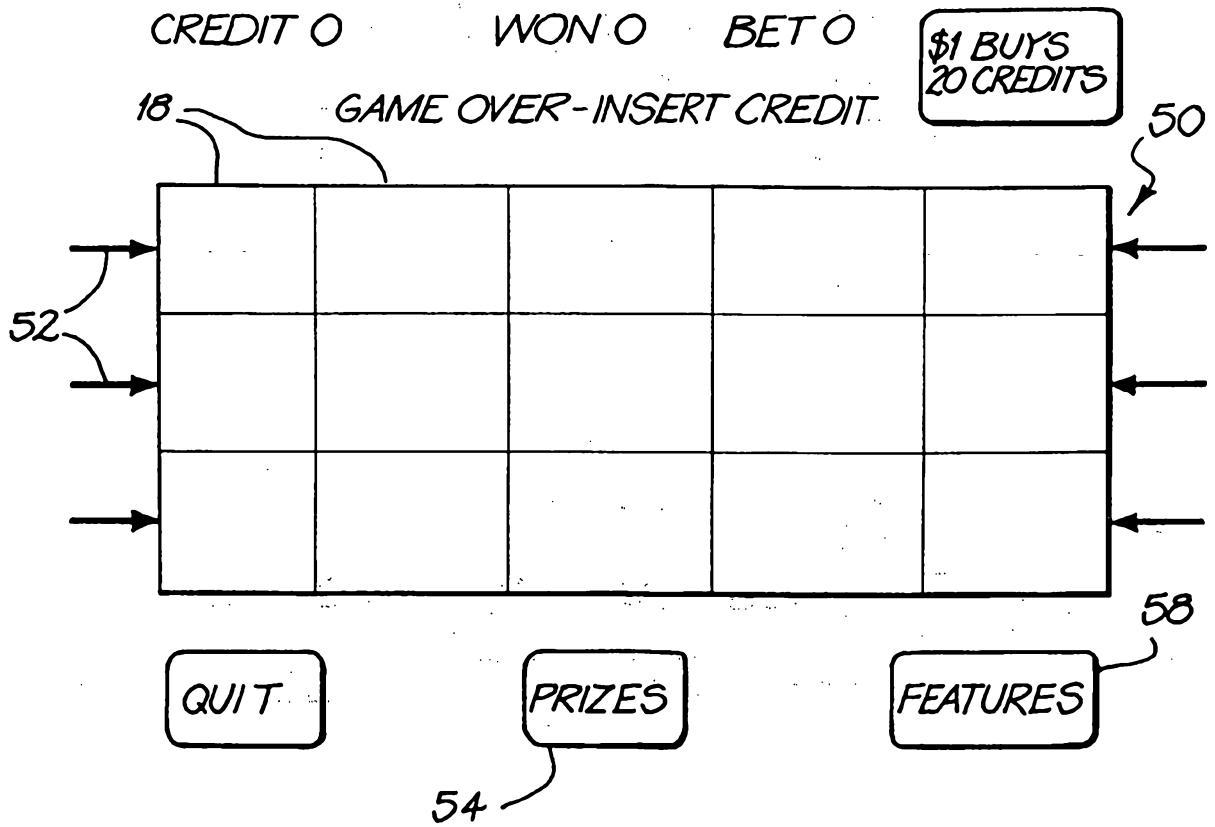

FIG. 4

WO 01/15055

5 / 9

PCT/AU00/00997

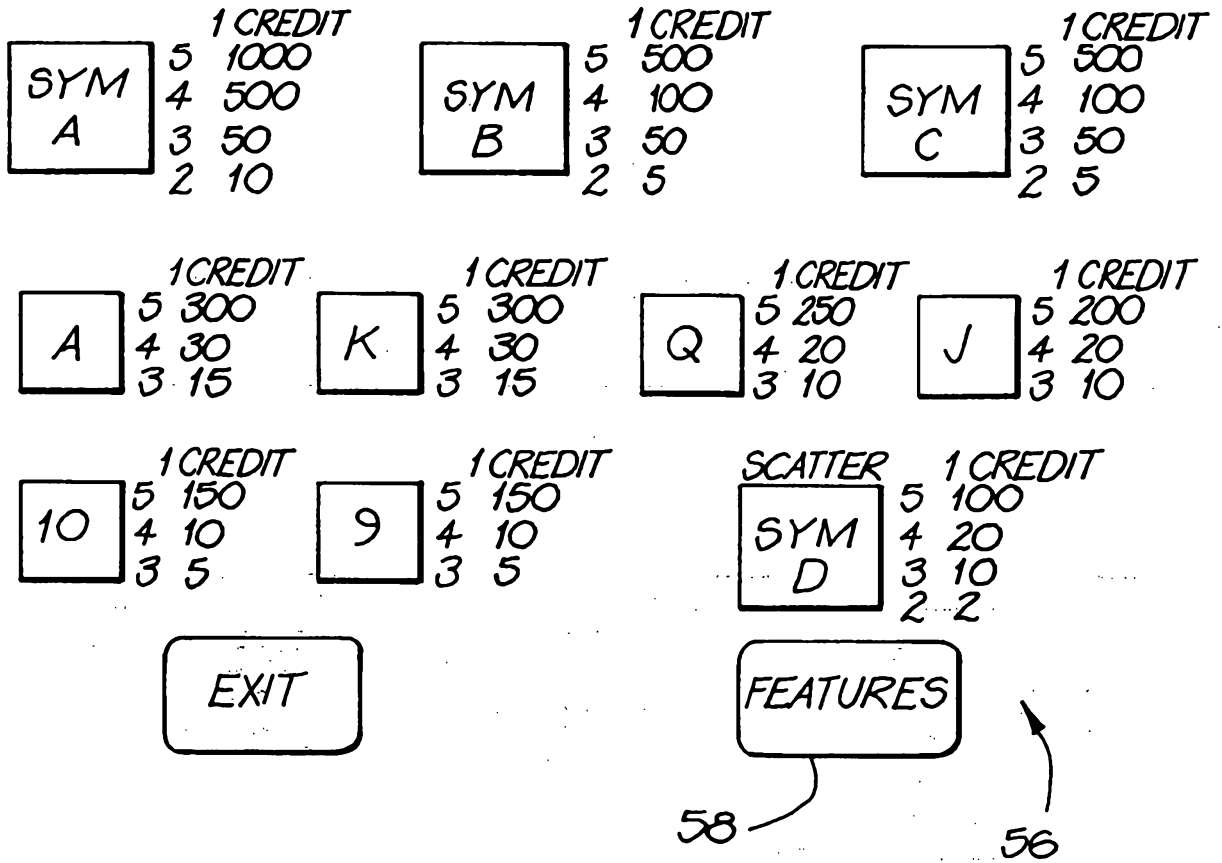

FIG. 5

WO 01/15055

PCT/AU00/00997

6 / 9

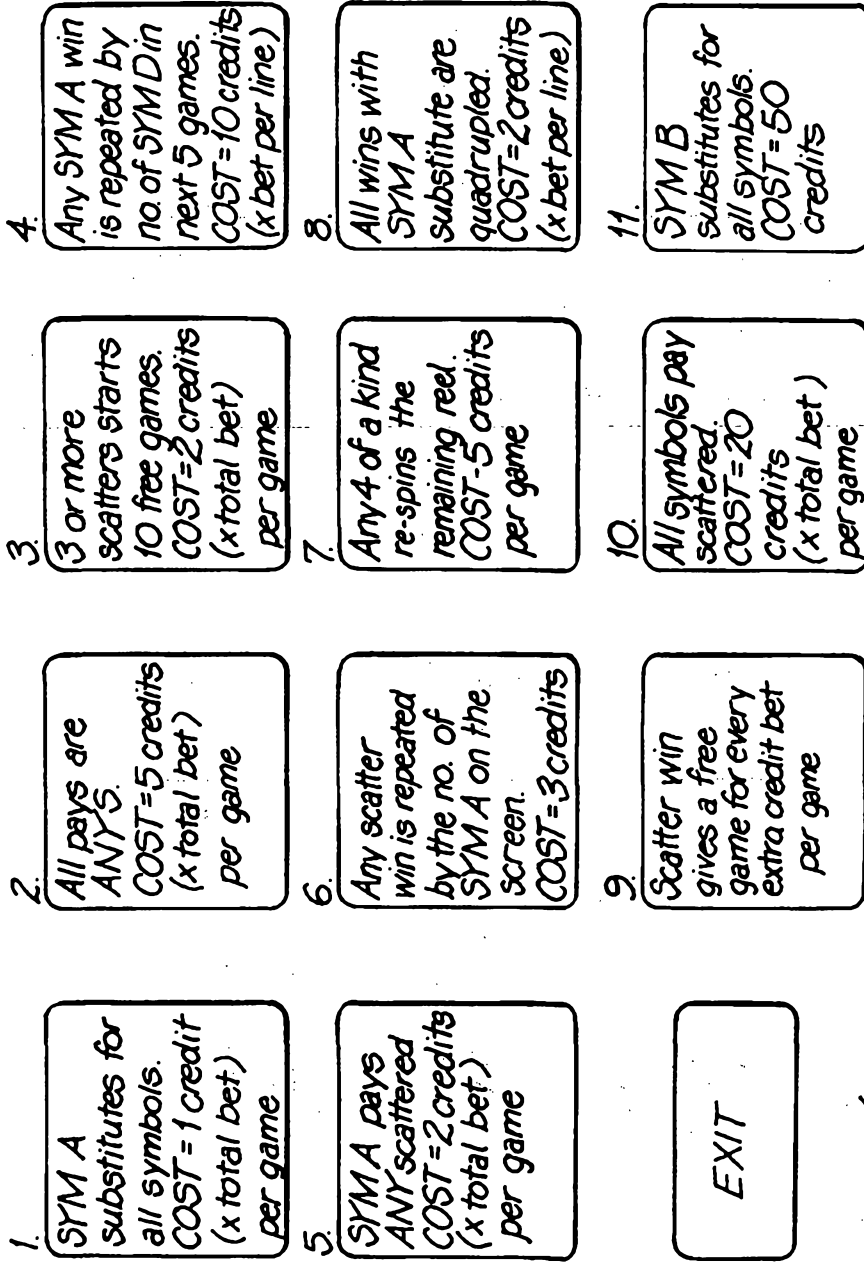

FIG. 6

60

62
↙

- 1. SYM A substitutes for all symbols.
- 2. All pays are ANYS.
- 3. 3 or more scatters starts 10 free games.
- 4. Any SYMA win is repeated by no. of SYMD in next 5 games.
- 5. SYM A pays ANY scattered
- 6. Any scatter win is repeated by the no. of SYMA on the screen.
- 7. Any 4 of a kind re-spins the remaining reel.
- 8. All wins with SYM A substitute are quadrupled.
- Cost is 1 credit per game for each feature selected or 5 features for 4 credits per game
- 9. Scatter win gives 5 bonus games where all wins are doubled.
- 10. All symbols pay scattered.
- 11. SYM B substitutes for all symbols.

EXIT

FIG. 7

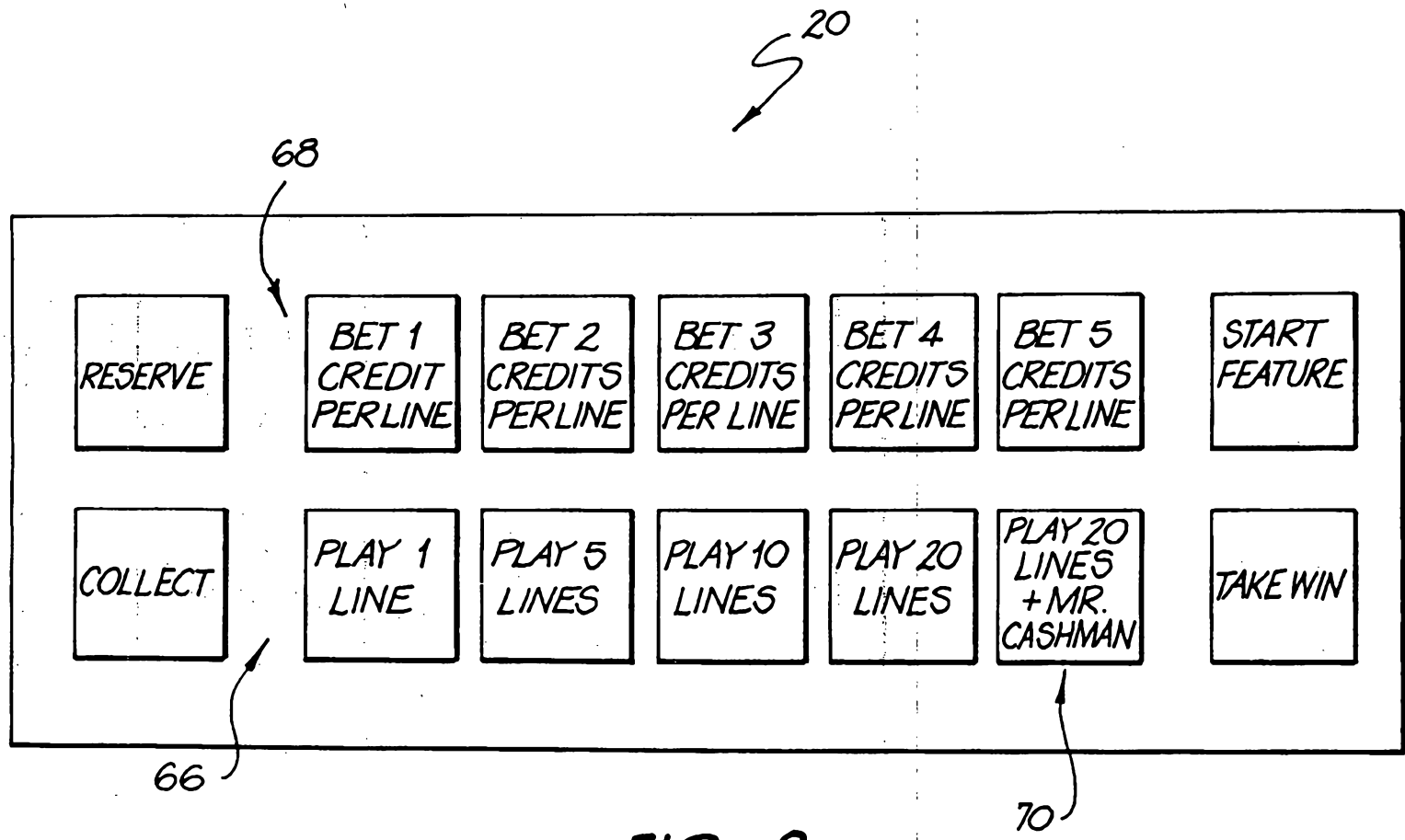

FIG. 8

WO 01/15055

PCT/AU00/00997

9 / 9

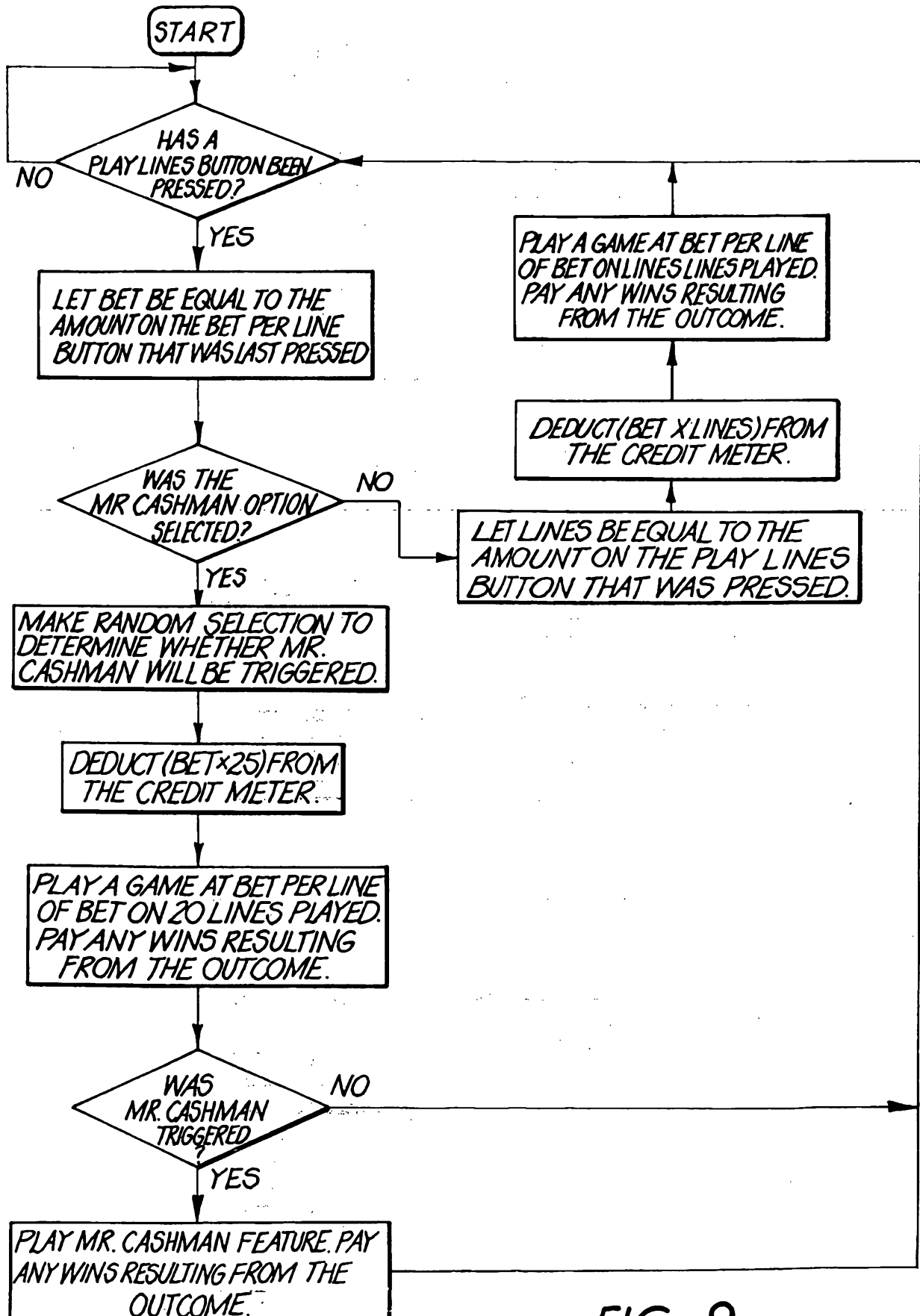

FIG. 9