



US0D1027845S

(12) **United States Design Patent**
Chen et al.

(10) **Patent No.:** **US D1,027,845 S**

(45) **Date of Patent:** **** May 21, 2024**

(54) **CHARGER FOR ELECTRIC VEHICLE**

2013/0021162 A1* 1/2013 DeBoer B60L 53/68
320/109

(71) Applicant: **Autel Intelligent Technology Corp., Ltd.**, Shenzhen (CN)

2015/0054462 A1* 2/2015 Weidinger B60L 53/16
320/109

(72) Inventors: **Huizhi Chen**, Guangdong (CN);
Yuelong Liao, Guangdong (CN)

2022/0340025 A1* 10/2022 Hitchcock H01R 13/5213

(73) Assignee: **Autel Intelligent Technology Corp., Ltd.**, Shenzhen (CN)

OTHER PUBLICATIONS

Autel MaxiCharger EV Charger, dated Aug. 31, 2022, [online], [site visited Jul. 13, 2023]. Available from Internet, URL: <https://www.amazon.com/dp/B0B8NFFYXT?th=1> (Year: 2022).*

(**) Term: **15 Years**

* cited by examiner

(21) Appl. No.: **29/826,679**

Primary Examiner — Shawn T Gingrich

(22) Filed: **Feb. 15, 2022**

Assistant Examiner — Caleb M Baker

(30) **Foreign Application Priority Data**

(74) *Attorney, Agent, or Firm* — Andrew C. Cheng

Aug. 17, 2021 (CN) 202130533237.7

(51) **LOC (14) Cl.** **13-02**

(52) **U.S. Cl.**
USPC **D13/107**

(58) **Field of Classification Search**

USPC D13/101, 103, 107, 108, 118, 119, 184;
D14/144, 251, 253, 307, 432, 434, 447
CPC H04M 1/04; G06F 1/1632; A45F 5/00;
B06L 11/1809; H02J 7/0044; H02J 7/02;
H02J 7/0045; H02J 7/00714; H02J 50/40;
H02J 50/005; H02J 50/10; H02J 50/402;
H02B 1/50

See application file for complete search history.

(56) **References Cited**

U.S. PATENT DOCUMENTS

D370,889 S * 6/1996 Anthony D13/154
5,680,926 A * 10/1997 Sandor H01R 13/625
200/50.11
D976,991 S * 1/2023 Wang D16/237
D999,161 S * 9/2023 Shen D13/107
2013/0020990 A1* 1/2013 DeBoer B60L 53/18
320/109

(57) **CLAIM**

We claim the ornamental design for a charger for electric vehicle, as shown and described.

DESCRIPTION

FIG. 1 is a front, right and top perspective view of a charger for electric vehicle showing our new design;
FIG. 2 is a rear, left and bottom perspective view thereof;
FIG. 3 is a front view thereof;
FIG. 4 is a rear view thereof;
FIG. 5 is a left side view thereof;
FIG. 6 is a right side view thereof;
FIG. 7 is a top plan view thereof;
FIG. 8 is a bottom plan view thereof; and,
FIG. 9 is an enlarged view of an encircled portion 9 of FIG. 1.

The dot-dash broken line portion of the figure drawings is included to show boundaries of enlarged views that form no part of the claimed design.

The broken lines depict portions of the charger for electric vehicle in which the design is embodied that form no part of the claimed design.

1 Claim, 9 Drawing Sheets

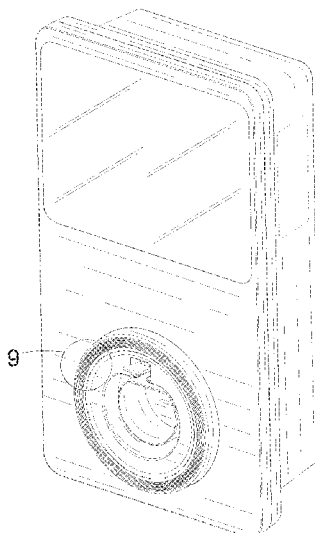

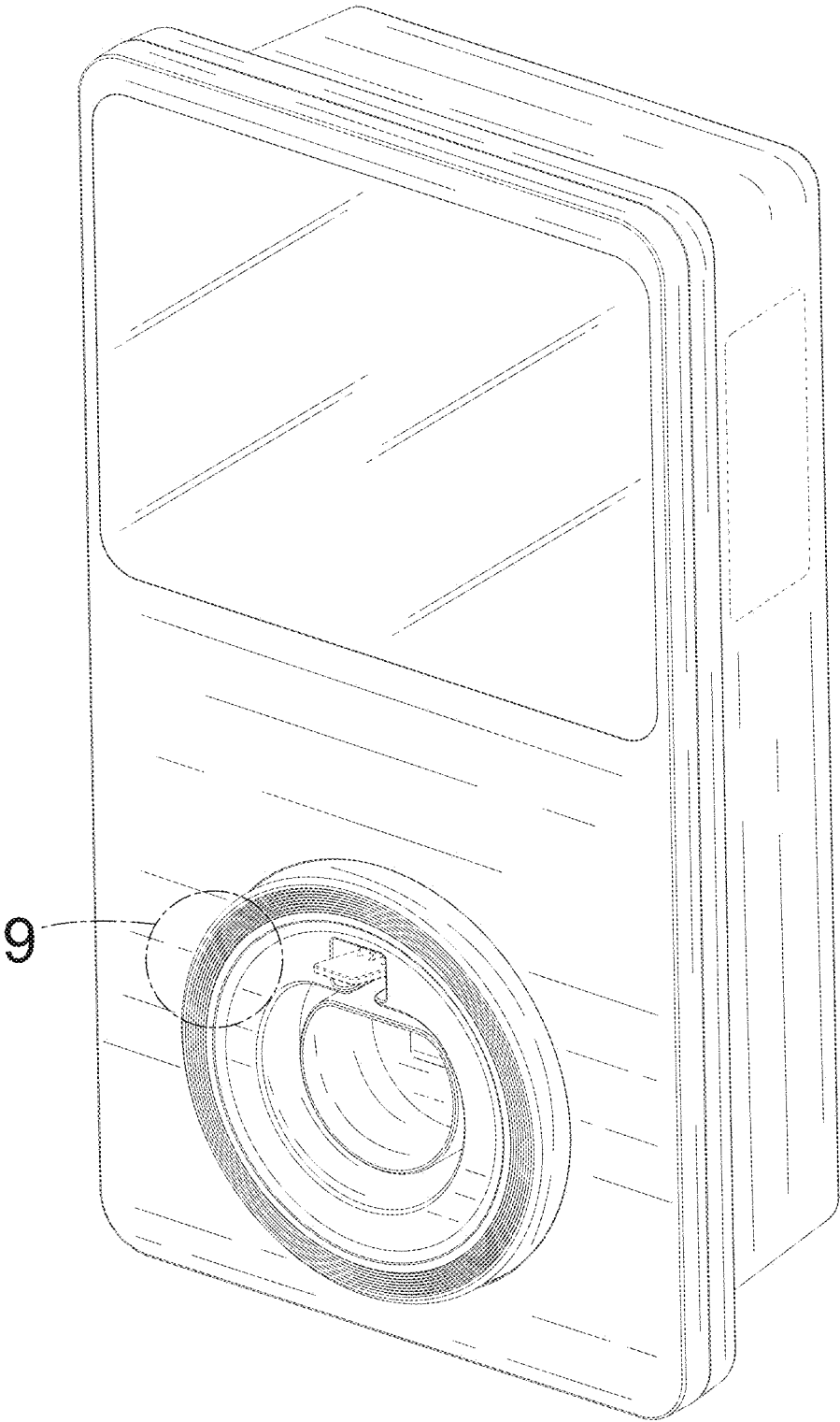

FIG. 1

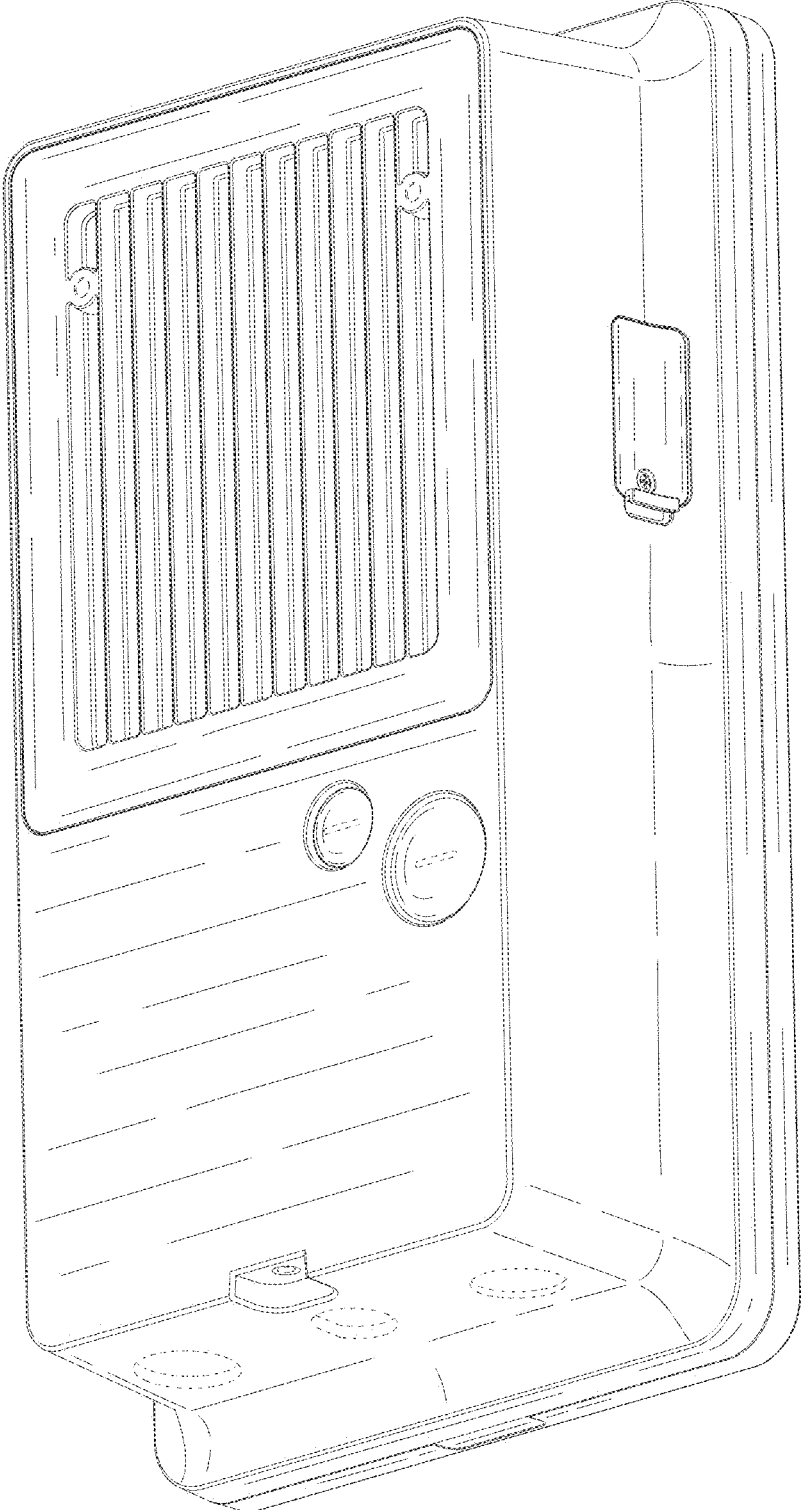

FIG. 2

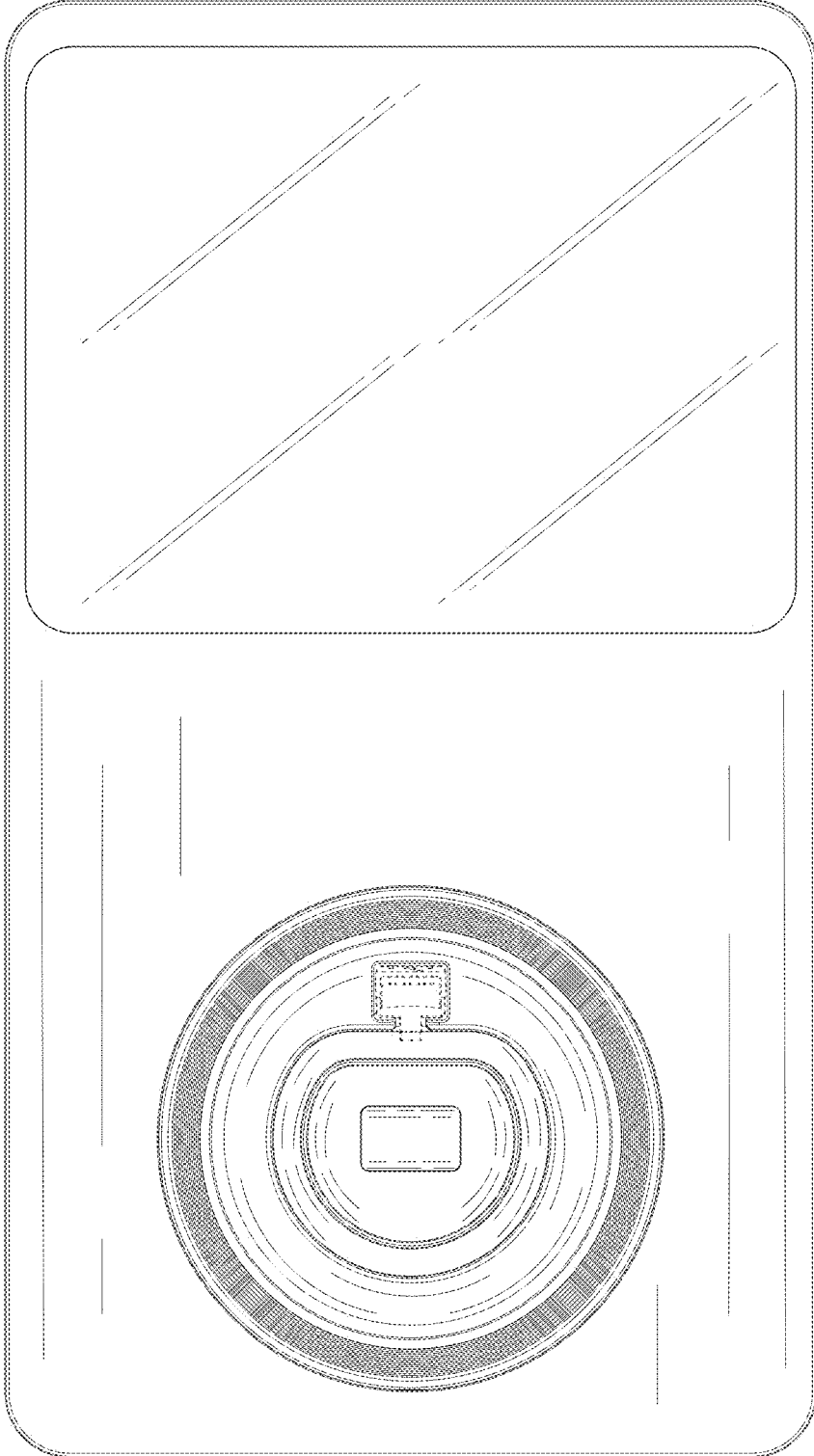

FIG. 3

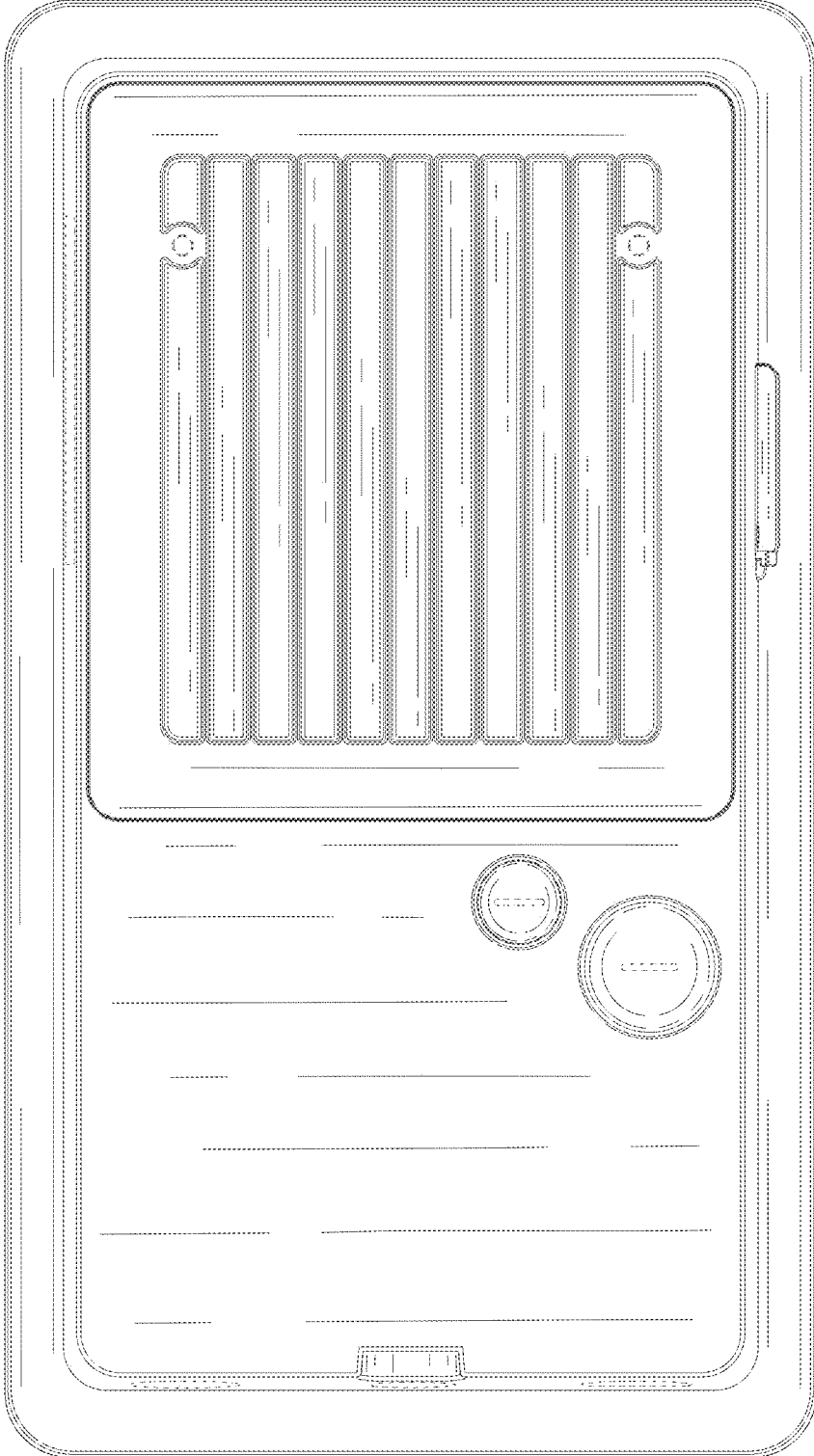

FIG. 4

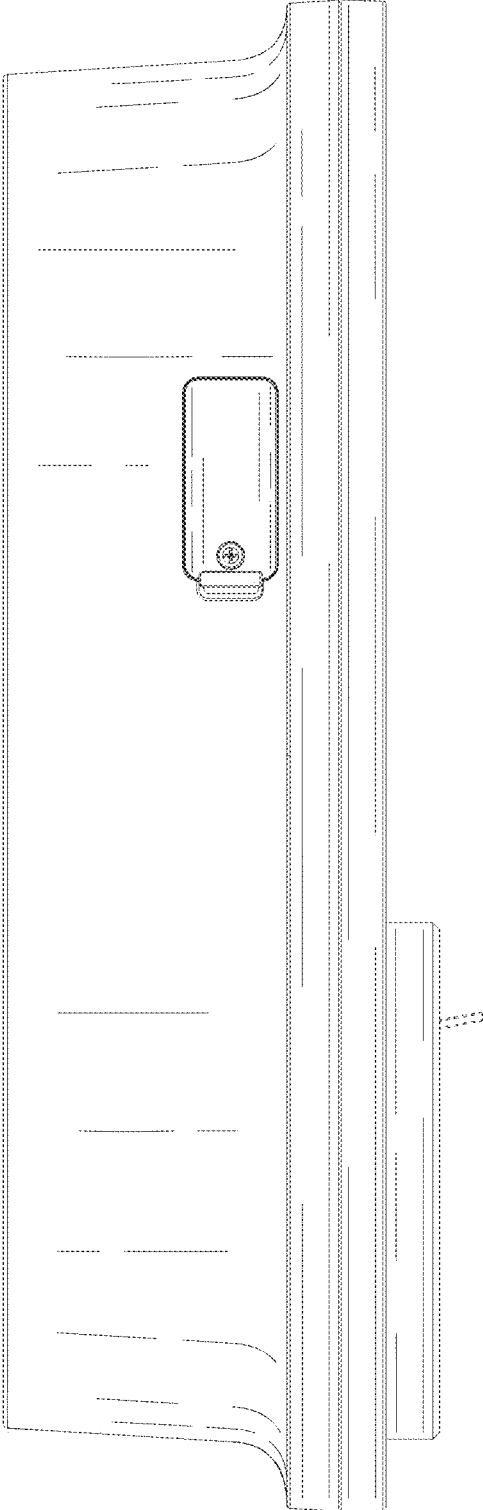

FIG. 5

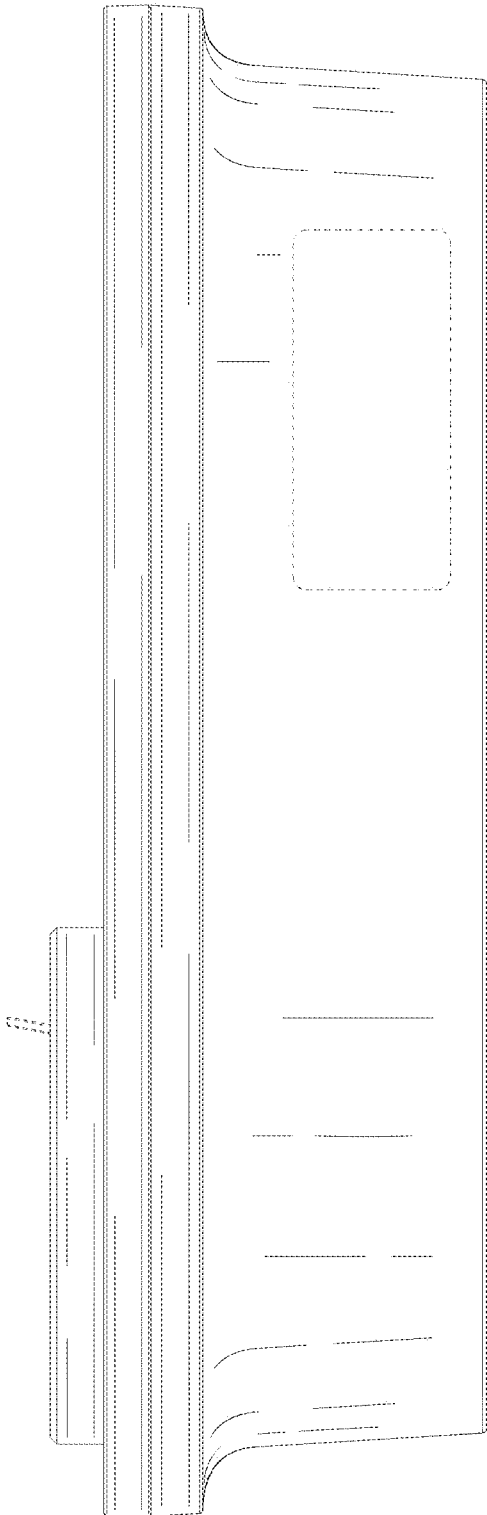

FIG. 6

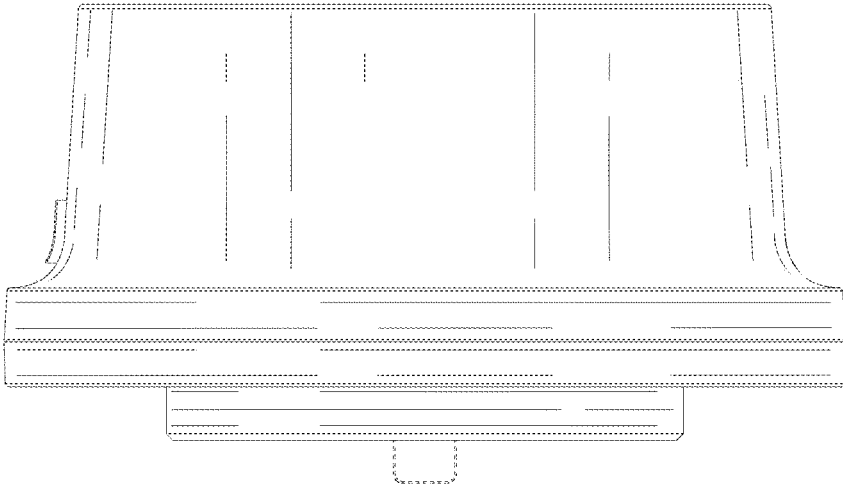

FIG. 7

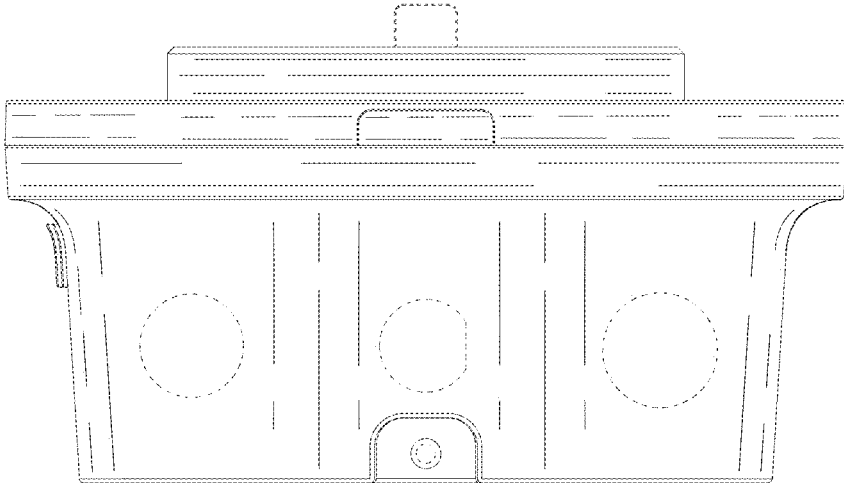

FIG. 8

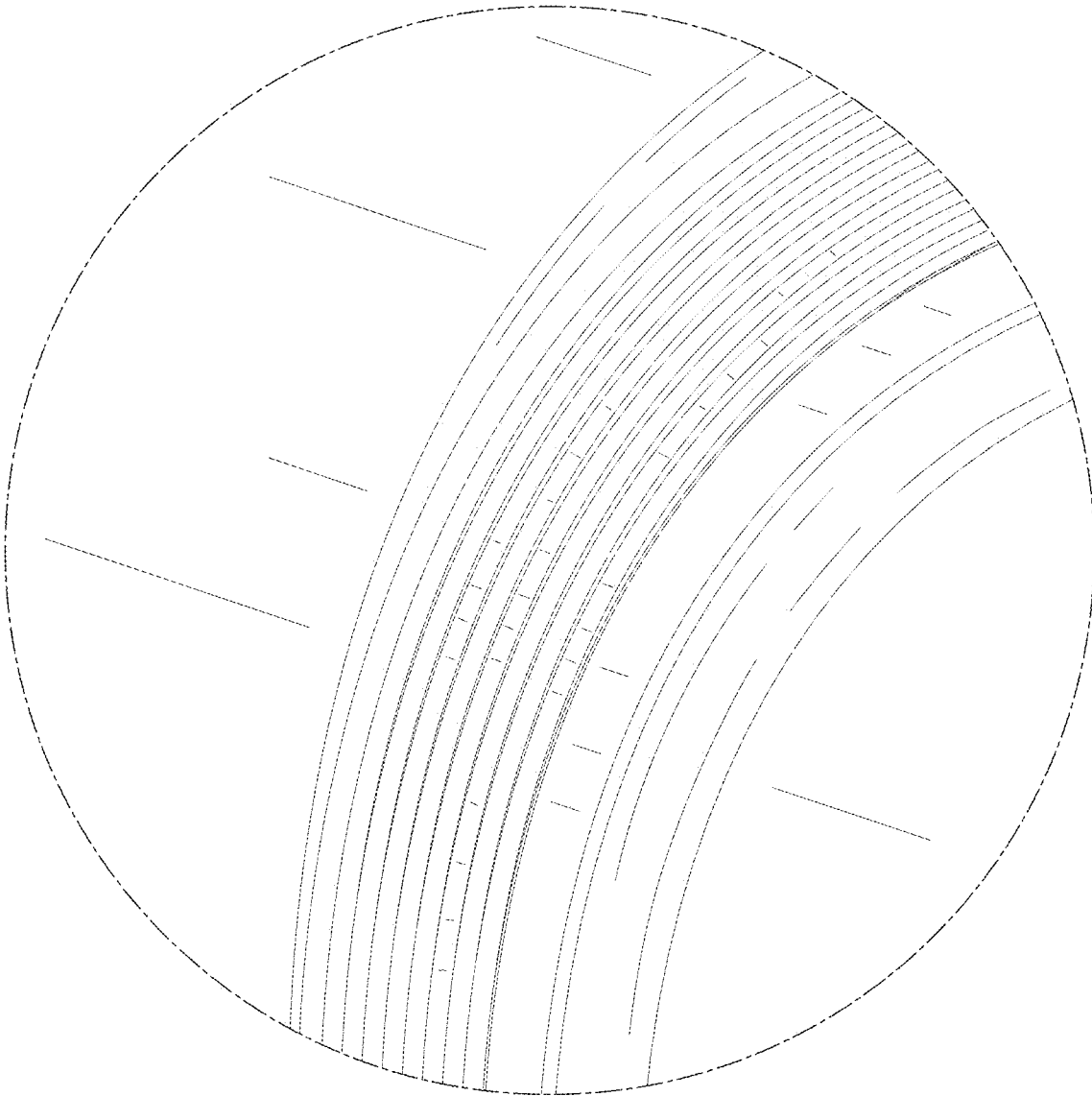

FIG. 9