

(12) **UK Patent Application** (19) **GB** (11) **2 410 051** (13) **A**

(43) Date of A Publication **20.07.2005**

(21) Application No: **0507206.1**
(22) Date of Filing: **09.01.2002**
Date Lodged: **08.04.2005**
(30) Priority Data:
(31) **2331021** (32) **09.01.2001** (33) **CA**
(31) **2354994** (32) **13.08.2001**
(62) Divided from Application No
0317299.6 under Section 15(4) of the Patents Act 1977

(51) INT CL⁷:
E21B 7/24 4/20 21/10
(52) UK CL (Edition X):
E1F FDD FEU FGL
(56) Documents Cited:
GB 2345931 A **EP 0406492 A1**
OA 000006683 A **US 5950736 A**
US 3507341 A
(58) Field of Search:
UK CL (Edition X) **E1F**
INT CL⁷ **E21B**
Other: **Online: WPI, EPODOC**

(71) Applicant(s):
Lewal Drilling Ltd
(Incorporated in Canada)
753 Vinedale Road, North Vancouver,
British Columbia, V7K 1A1, Canada

(continued on next page)

(54) Abstract Title: **Pressure pulsing apparatus at surface and method for drilling**

(57) A method for underground drilling comprises generating high intensity pressure pulses at the surface and coupling the pressure pulses into drilling mud 21 being pumped into the drill string 27. The pressure pulses propagate down the drill string to do work at an underground location 34. The pressure pulses are preferably generated by periodically interrupting flow of the drilling mud in a conduit 22, thereby creating a water hammer effect. Intensity of the pulses can be intensified at the bit 30 using nozzles. The pulses can also be used to drive pistons (74, fig 12) to generate vibration. The pulses reduce the torque requirements of the drill.

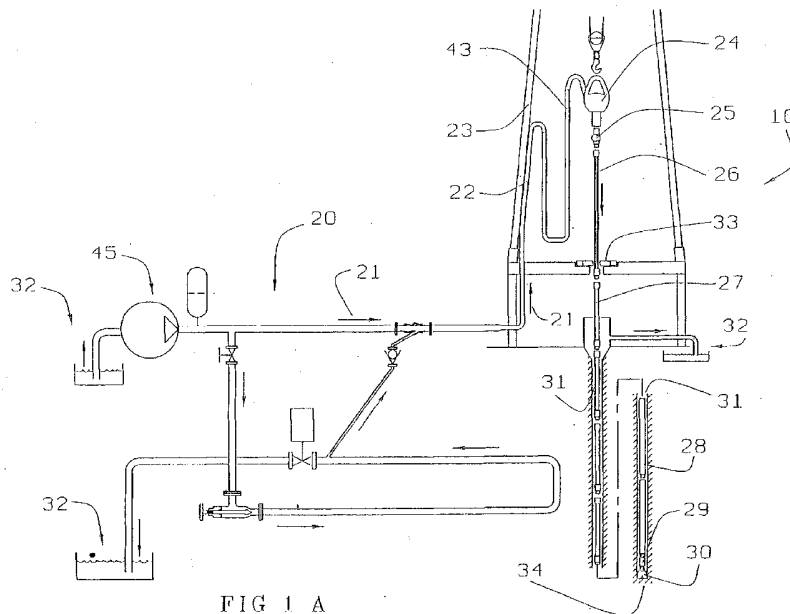

At least one drawing originally filed was informal and the print reproduced here is taken from a later filed formal copy.

This print takes account of replacement documents submitted after the date of filing to enable the application to comply with the formal requirements of the Patents Rules 1995

Original Printed on Recycled Paper

GB 2 410 051 A

GB 2410051 A continuation

(72) Inventor(s):
Bruno Walter

(74) Agent and/or Address for Service:
Fitzpatricks
1 Blythswood Square, GLASGOW,
G2 4AD, United Kingdom

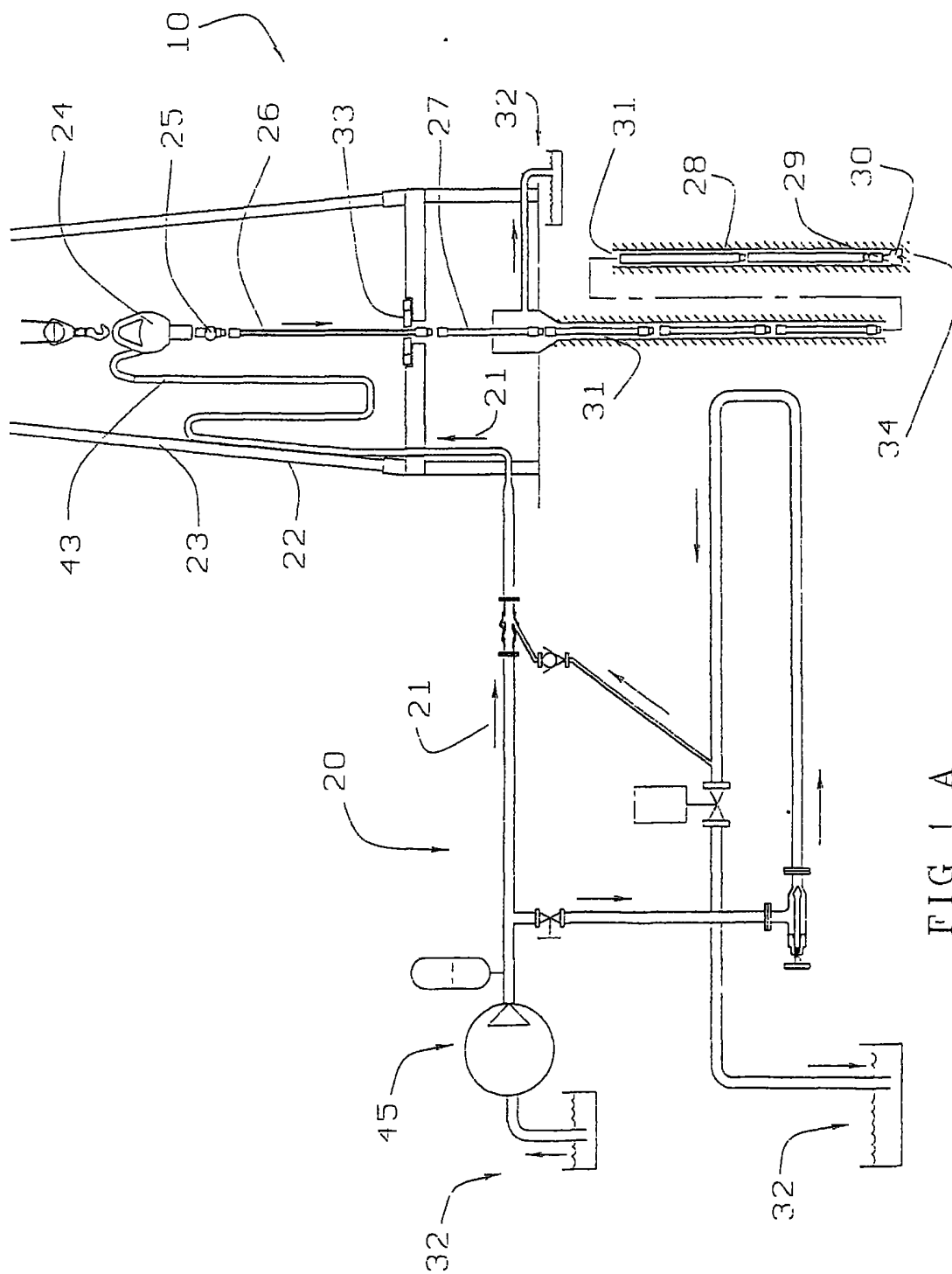

FIG 1 A

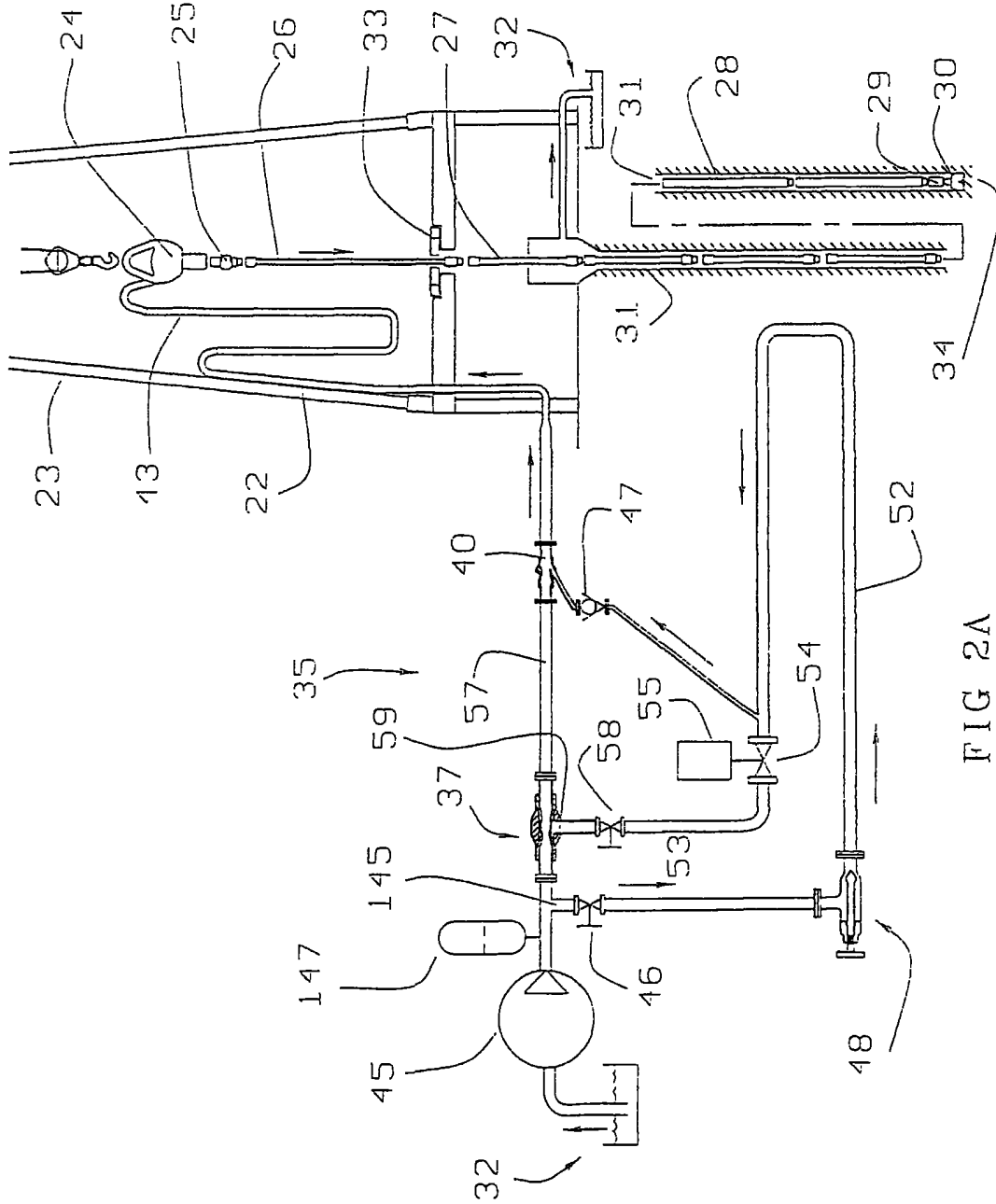

FIG 2A

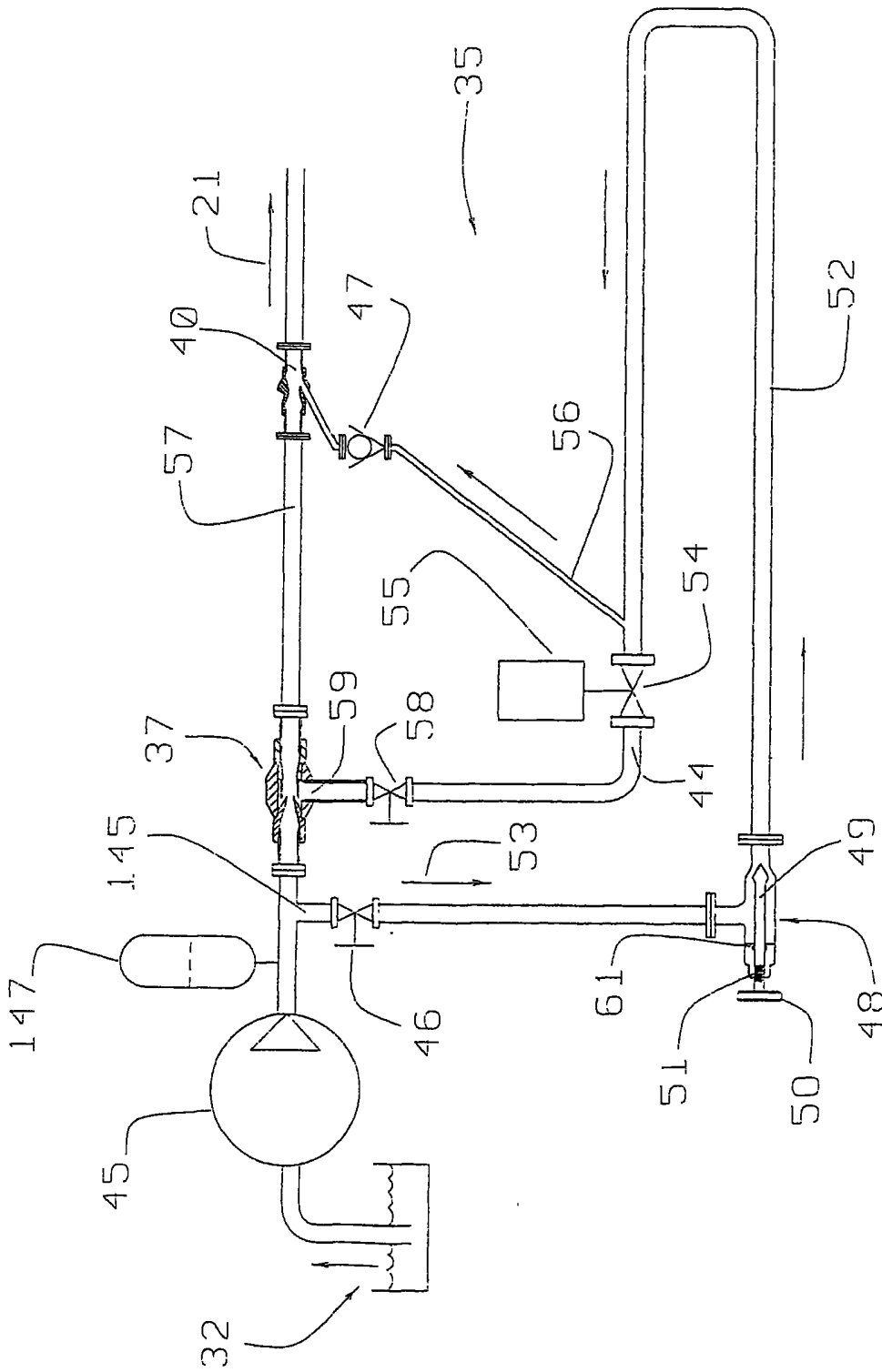

FIG 2B

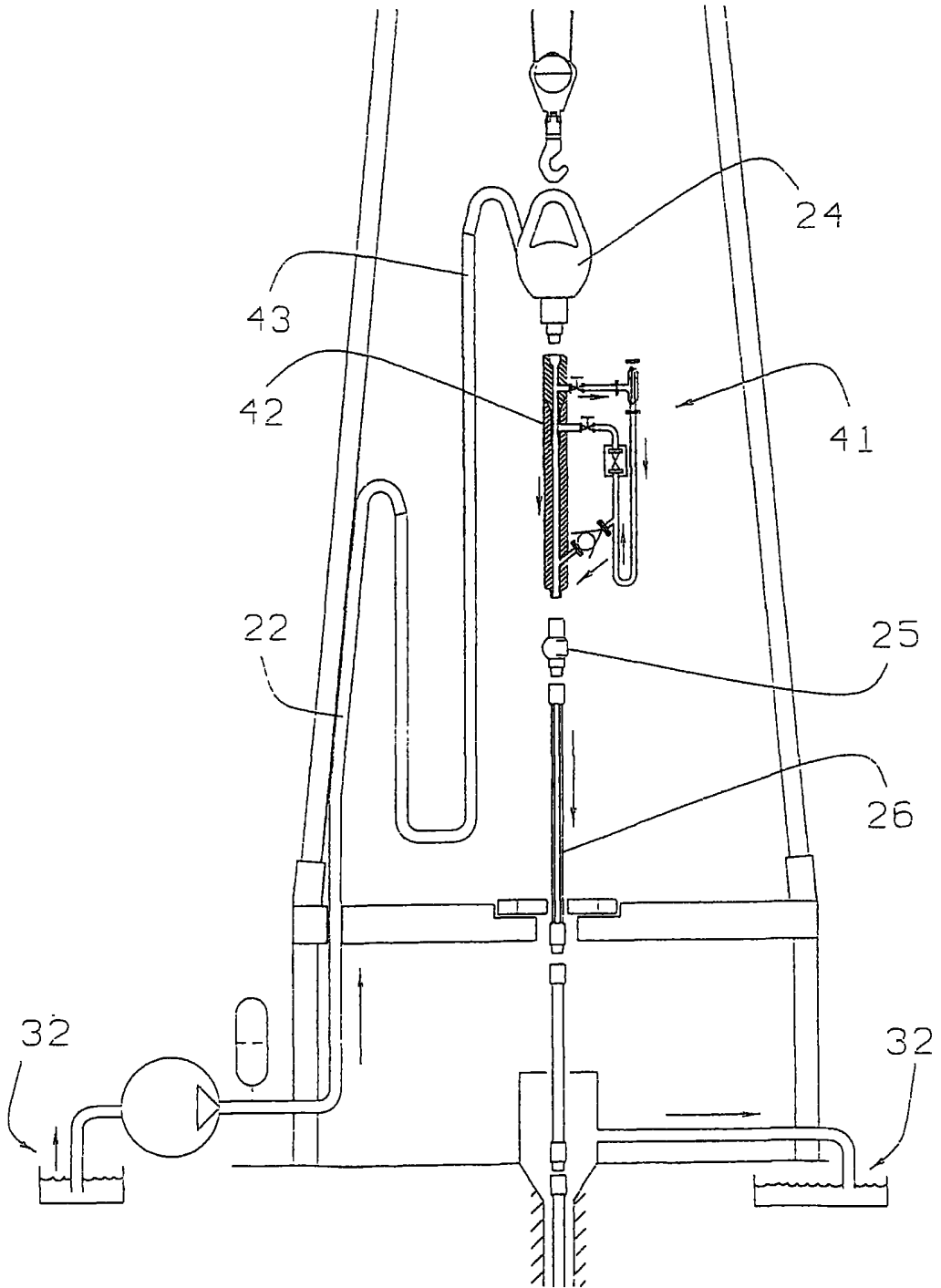

FIG. 3A

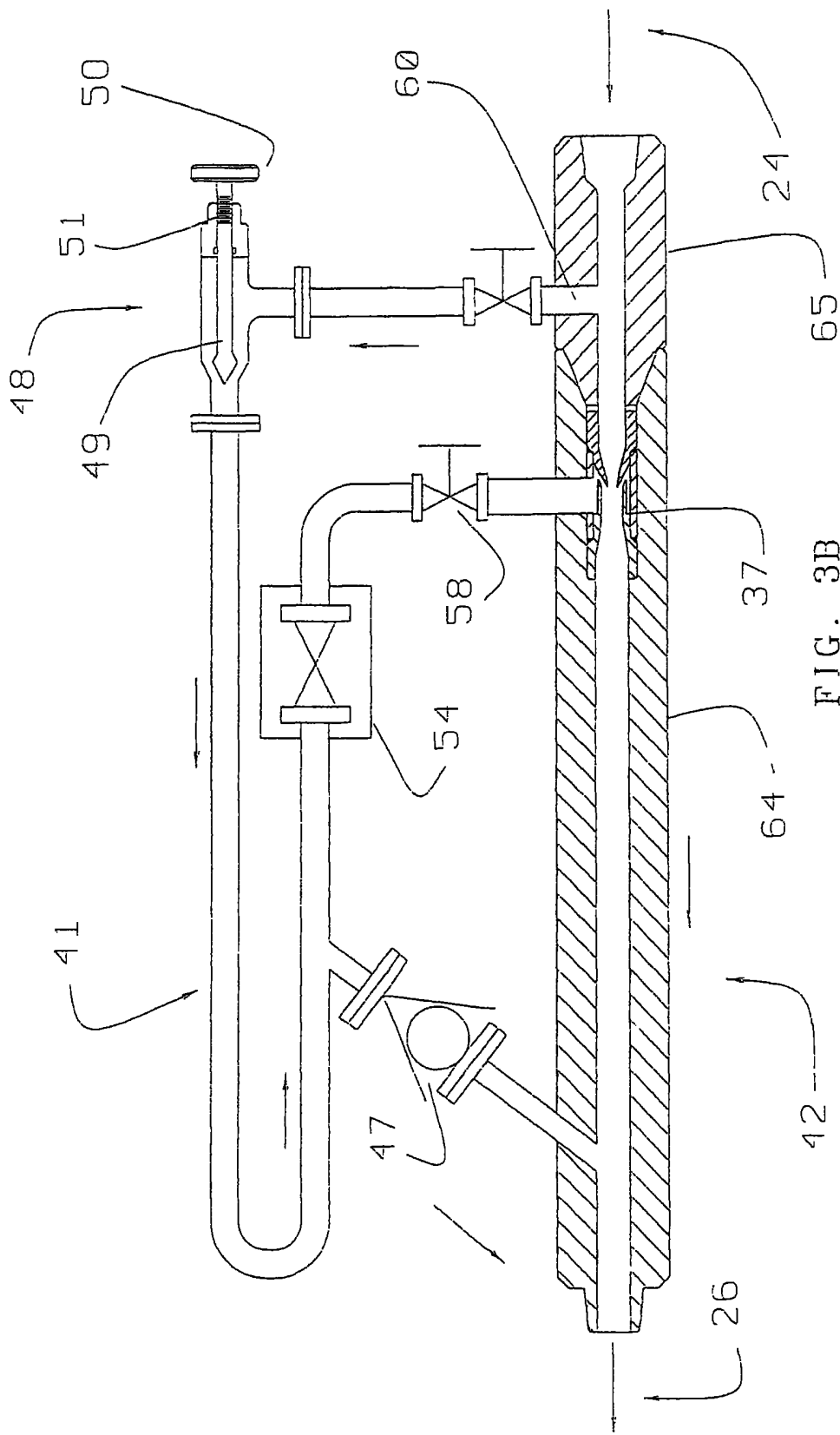

FIG. 3B

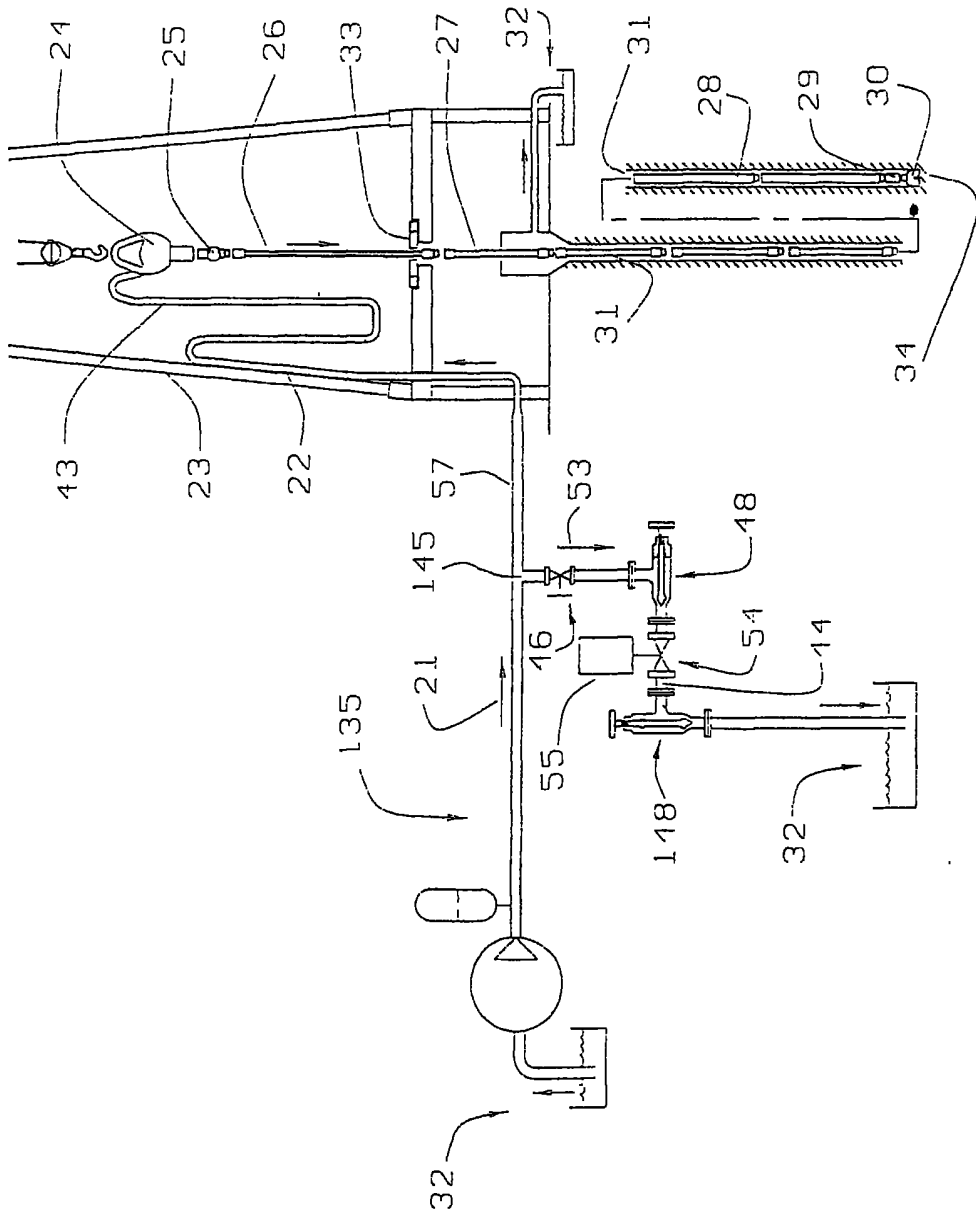

FIG 4

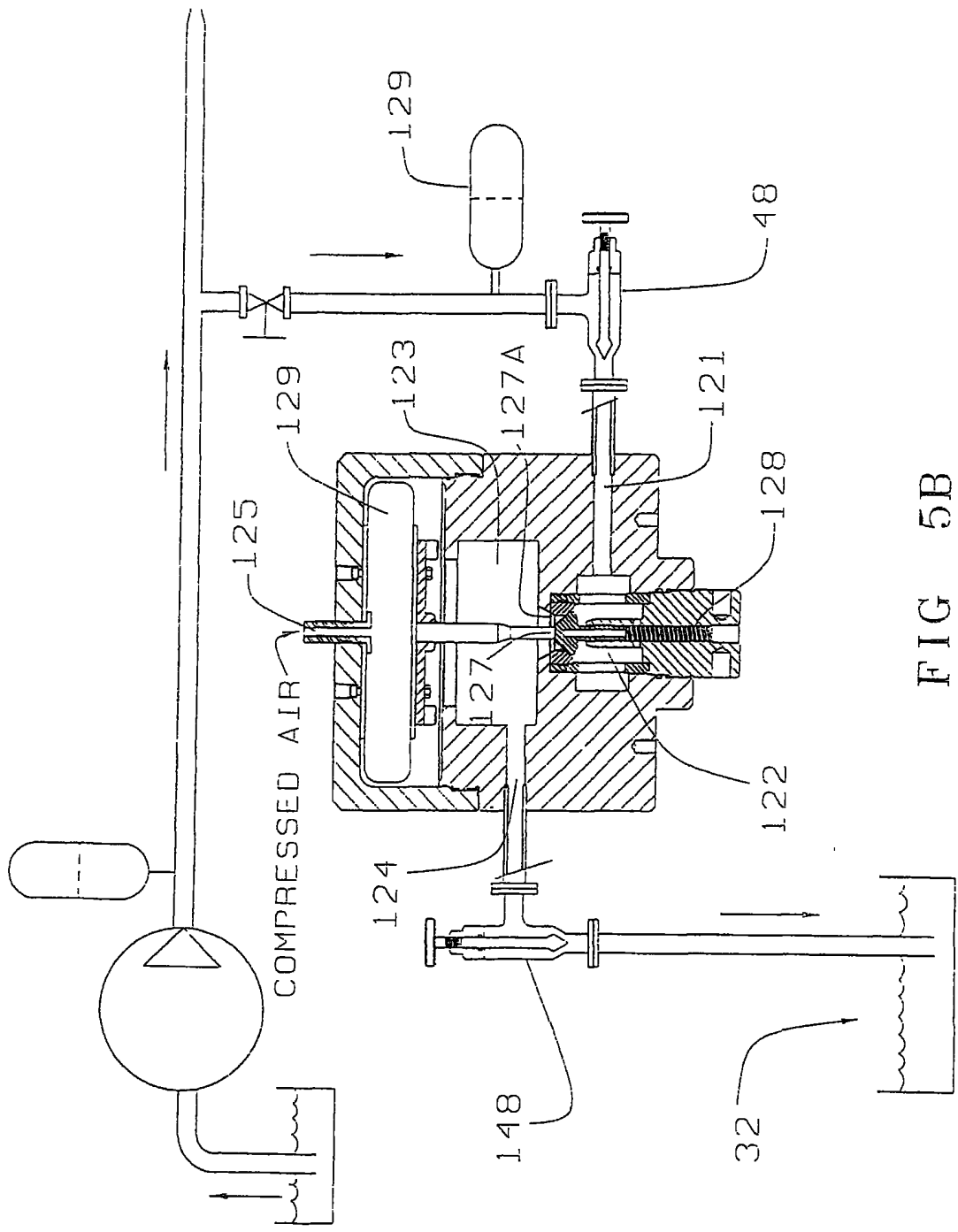

FIG 5B

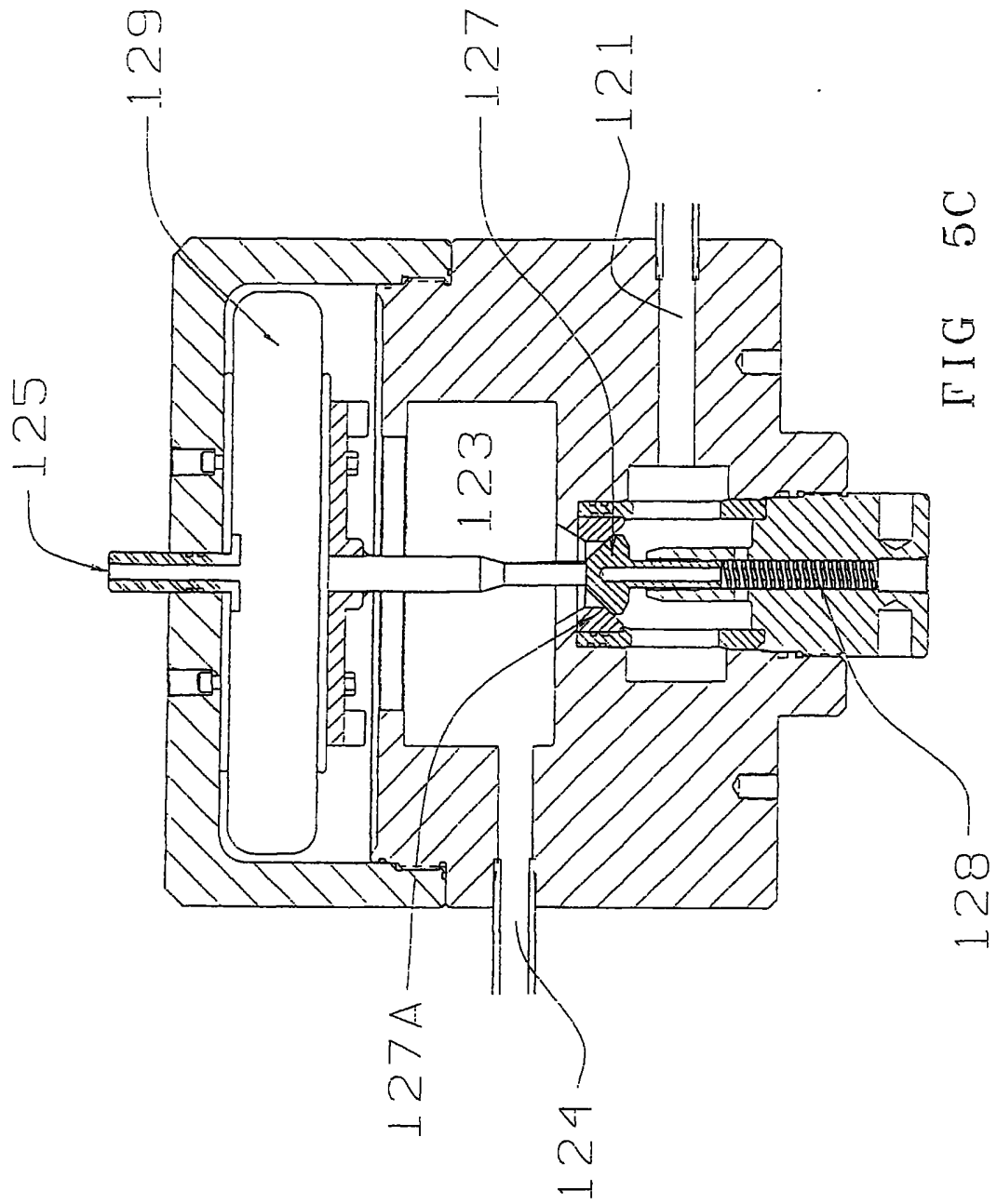

FIG 5C

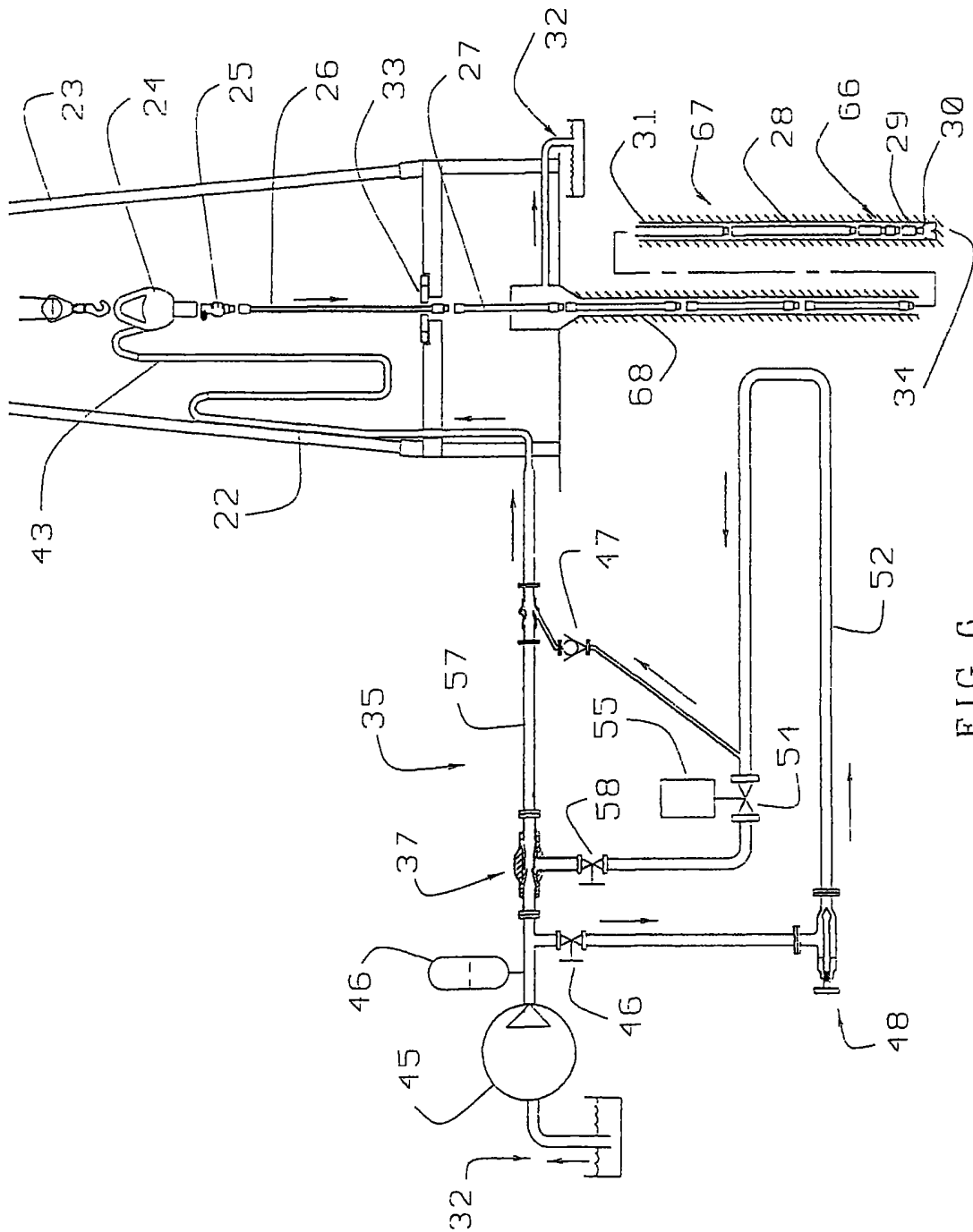

FIG. 6

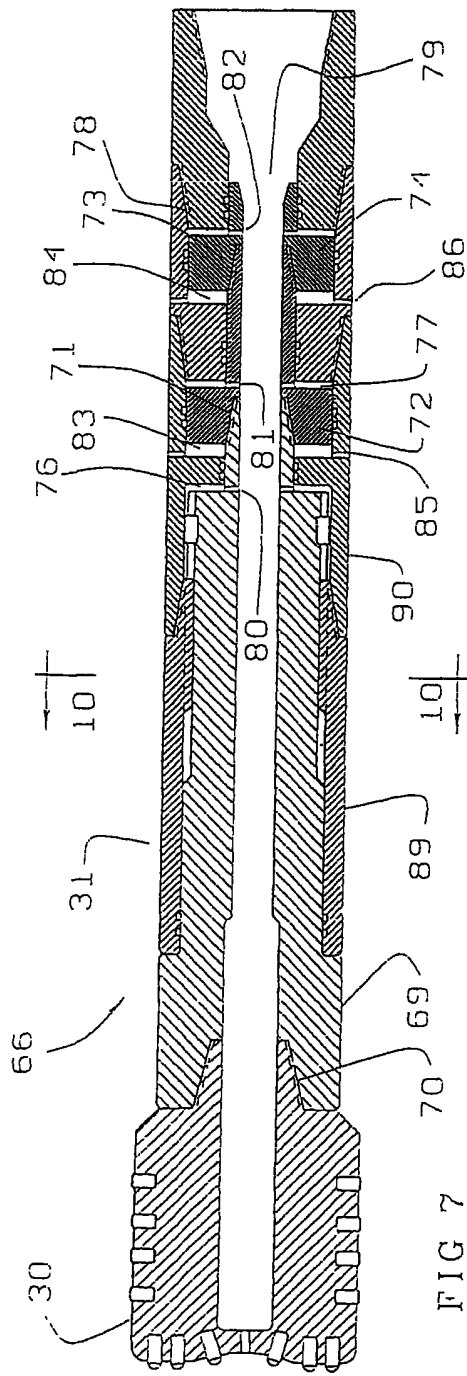

FIG 7

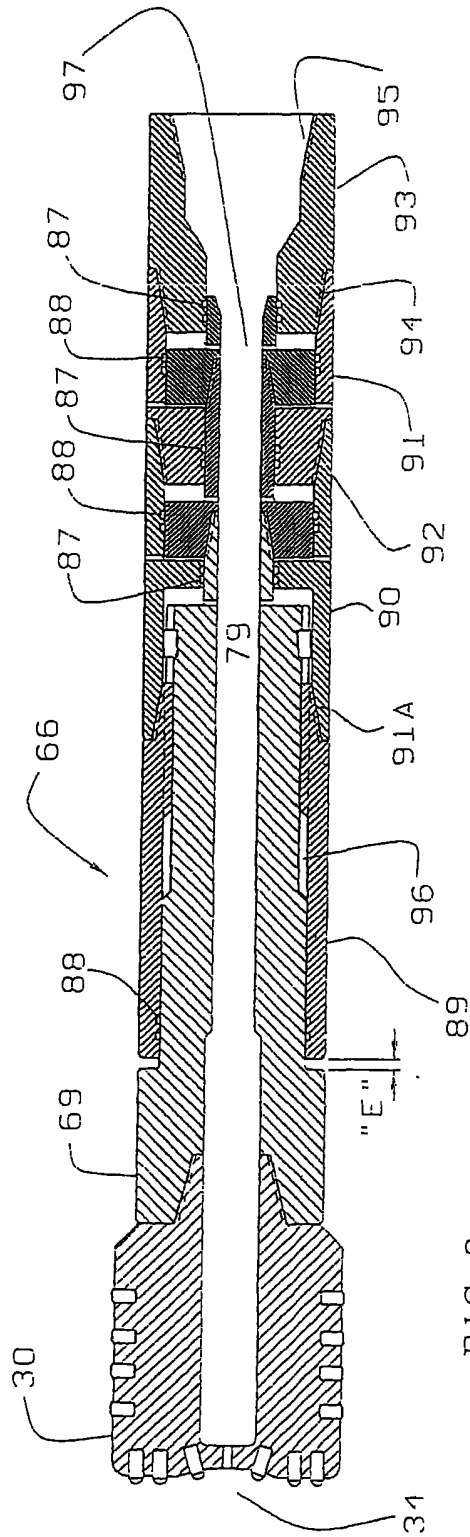

FIG 8

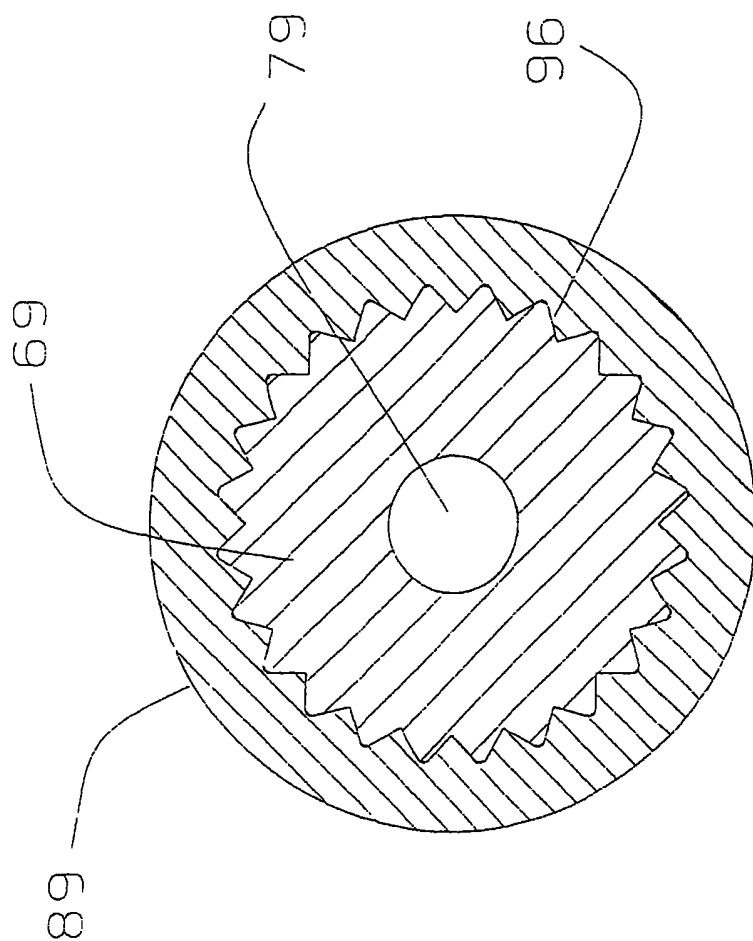

FIG 9

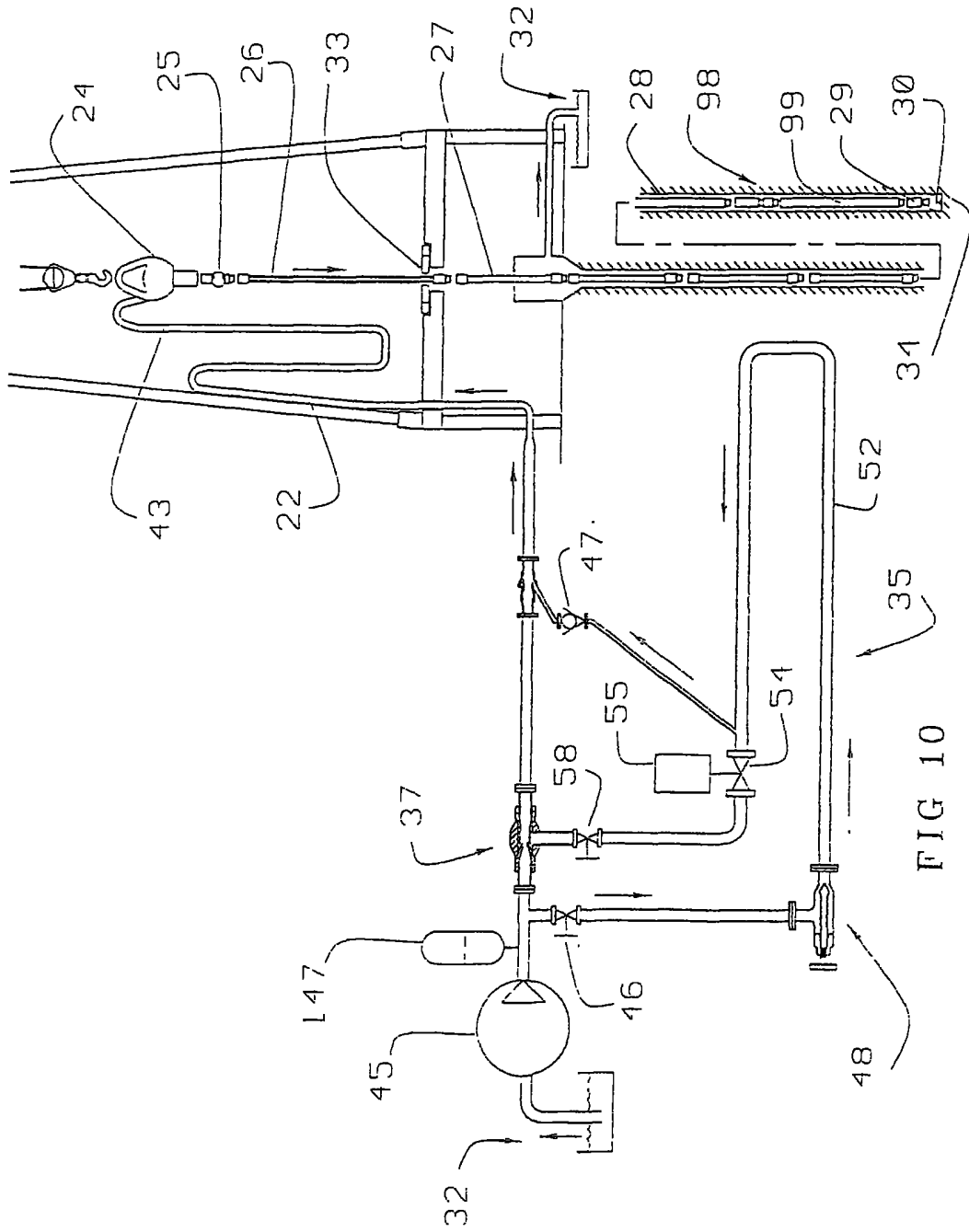

FIG 10

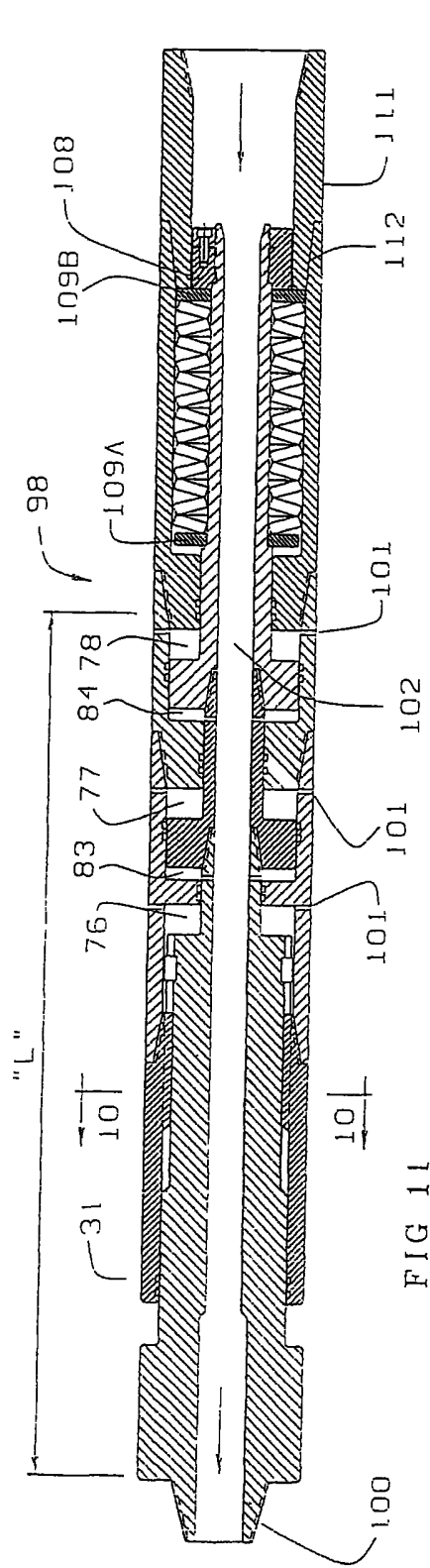

FIG 11

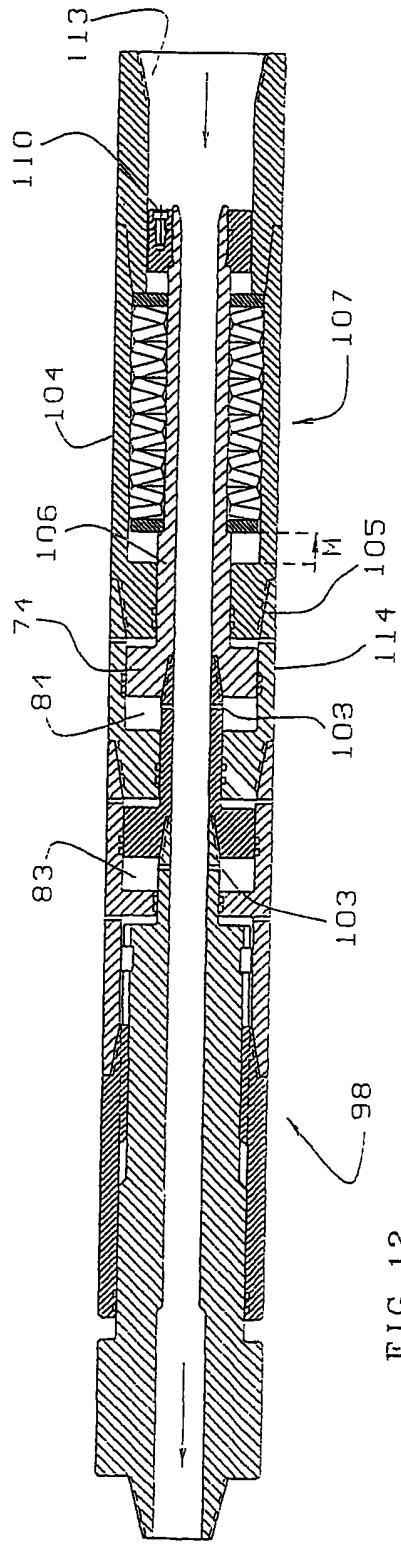

FIG 12

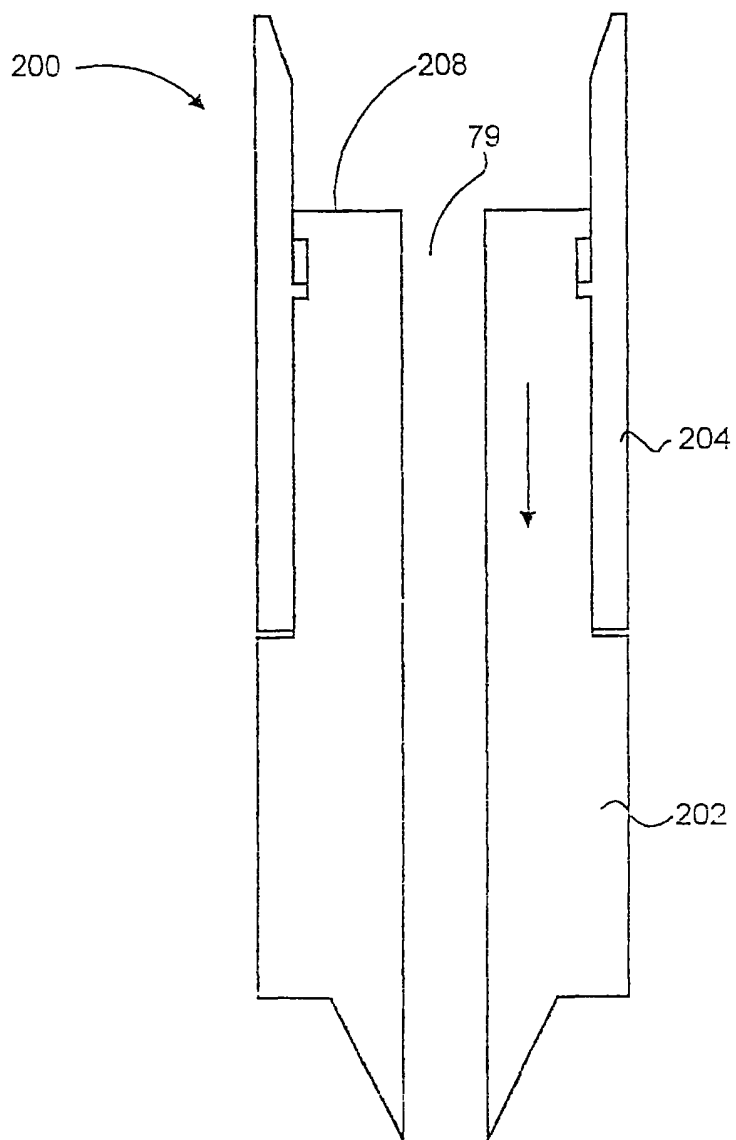

FIGURE 13

|

PRESSURE PULSING APPARATUS AT SURFACE AND METHOD FOR DRILLING

Cross-Reference to Related Applications

5

[0001] This application is related to and claims the benefit of the filing dates of Canadian patent application No. 2,331,021 filed on 9 January, 2001 and Canadian patent application No. 2,354,994 filed on 13 August 2001.

10

Field of the Invention

[0002] This invention relates to underground drilling. In particular, the invention relates to underground drilling methods which involve the creation of acoustic pulses in drilling fluid, the use of such pulses to operate downhole tools, and the use of such pulses to increase drilling rates. The invention also relates to apparatus adapted to practice the methods of the invention.

15

20

Background

[0003] Deep wells such as oil and gas wells are typically drilled by rotary drilling methods. Some such methods are described in Walter, US patent No. 4,979,577. Apparatus for rotary drilling typically comprises a suitably constructed derrick. A drill string having a drill bit at its lower end is gripped and turned by a kelly on a rotary table.

25

30

[0004] During the course of drilling operations, drilling fluid, often called drilling mud, is pumped downwardly through the hollow drill string. The drilling fluid exits the drill string at the
5 drill bit and flows upwardly along the well bore to the surface. The drilling fluid carries away cuttings, such as rock chips.

[0005] The drill string is typically suspended from
10 a block and hook arrangement on the derrick. The drill string, comprises a drill pipe, drill collars and may comprise drilling tools, such as reamers and shock tools, with the drill bit being located at the extreme bottom end.

15 [0006] Drilling a deep underground well is an extremely expensive operation. Great cost savings can be achieved if the drilling process can be made more rapid. A large number of factors affect the
20 penetration rate that can be achieved in drilling a well.

[0007] Around the late 1940s, it was discovered that drilling efficiency could be improved by
25 equipping the openings in drill bits, which allow escape of drilling fluid with nozzles. The nozzles provide high velocity jets of drilling fluid at the drill bit. This innovation resulted in a dramatic increase in achievable drilling rates. Today,
30 almost all drill bits are equipped with high velocity nozzles to take advantage of this increased efficiency. It is worthwhile to note that

between 45 - 65% of all hydraulic power output from a mud pump is typically used to accelerate the drilling mud in the drill bit nozzles.

5 [0008] The flow rate of drilling fluid affects penetration rates. Rock drill bits drill by forming successive small craters in a rock face as individual drill bit teeth contact the rock face. Once a drill bit tooth has formed a crater, rock
10 chips must be removed from the crater. The amount of drilling fluid necessary to effect proper chip removal depends upon the type of rock formation being drilled and the shape of the crater produced by the drill bit teeth. Maintaining an appropriate
15 flow of drilling fluid is important for maintaining a high penetration rate.

[0009] The weight on the drill bit also has a very significant effect on drilling penetration rates.
20 If adequate cleaning of rock chips from the rock face is effected, doubling of the drill bit weight will roughly double the drilling penetration rate (i.e. drilling/penetration rate is typically directly proportional to weight on the drill bit).
25 However, if inadequate cleaning takes place, further increases in the drill bit weight do not cause corresponding increases in penetration rate because rock chips not cleared away are being reground, thus wasting energy. If this situation
30 occurs, one solution is to increase pressure and flow of the drilling fluid in an attempt to effect

better clearing of rock chips from the vicinity of the drill bit.

5 [0010] Further information on rotary drilling and penetration rate may be found in standard texts on the subject, such as Preston L. Moore's *Drilling Practices Manual*, published by PennWell Publishing Company (Tulsa, Oklahoma).

10 [0011] Downhole vibrating tools known as mud hammers have been developed in an effort to increase drilling penetration rates. A typical mud hammer comprises a striker hammer which is caused to repeatedly apply sharp blows to an anvil. The sharp blows are transmitted, through the drill bit to the teeth of the drill bit. This has been found to increase drilling penetration rates. Mud hammers are expensive to operate as drill bit life is significantly reduced by the use of a mud hammer.

20

[0012] In another effort to increase drilling penetration rates of drill strings has yielded various downhole devices which exploit the water hammer effect to create pulsations in the flow of drilling mud. Such devices tend to enhance the hydraulic action of the drilling fluid. Their use has a positive effect on rock chip removal and, consequently, drilling penetration rates. Another effect of these devices is to induce vibrations in the drill string, more specifically in the drill bit itself. This too has a positive effect on drilling penetration rates. Examples of such

devices can be found in US patent No. 4, 819, 745
(Walter), US patent No. 4, 830, 122 (Walter), US
patent No. 4, 979, 577 (Walter), US patent No.
5,009, 272 (Walter) and US patent No. 5, 190, 114
5 (Walter).

[0013] While the devices described in these patents
have proven to be effective at increasing drilling
penetration rates they have a number of
10 disadvantages which has prevented their widespread
adoption. It is difficult to design such a tool
which will operate reliably under the constantly
changing properties of drilling mud and the
constantly increasing hydrostatic pressure at
15 downhole locations. This problem is exacerbated by
the small space within which downhole tools must
fit. In many drilling situations the downhole tools
have an outside diameter of only 4 3/4 inches.
Space constraints impose onerous constraints on the
20 design of such tools. Other problems with these
devices include:

- Downhole conditions are harsh. Operating parts
of these tools may not withstand downhole
operating conditions for extended periods of
25 time.
- Operating parameters cannot be adjusted while
drilling is ongoing. This makes it difficult
to optimize the performance of these tools.
- It is not possible to switch these tools on or
30 off while drilling. This makes it difficult to
ascertain the effectiveness of the tools since
there is a significant variation in drilling

penetration rates from well-to-well even if all drilling parameters are kept constant.

- During drilling, these tools are only accessible for repair when they are brought to the surface.

5
10 [0014] Despite the significant progress that has been made in underground drilling technology over the past century there remains a need for drilling methods and apparatus which provide increased drilling penetration rates. This need is Any significant increase

Summary of the Invention

15

[0015] This invention provides methods for underground drilling which involve generating high intensity pressure pulses at or near the surface and then allowing those pulses to propagate in drilling mud down a drill string. The pulses may cause fluctuations in the flow of drilling mud exiting nozzles in a drill bit.

25 [0016] The invention also provides apparatus for producing high intensity pulses. The apparatus includes a valve which can suddenly substantially block a conduit in which drilling mud is flowing, thereby creating a water hammer in the flowing drilling mud. In one embodiment of the invention a partial flow from the same mud pump that is used to pump drilling mud down a drill string is diverted into a pulse generating circuit. The pulse

generating circuit includes a conduit through which drilling mud can flow and a flow interrupter valve downstream in the conduit. The apparatus may direct drilling mud exiting the flow interrupter valve may
5 to a mud tank or may comprise a jet pump, or other apparatus in the main mud conduit which causes a reduced pressure at a location in the main mud conduit where the diverted drilling mud is reintroduced into the main mud conduit. The
10 apparatus includes a valve controller which operates the flow interrupter valve on a periodic basis.

[0017] Another aspect of the invention provides
15 downhole tools that are operated by pressure pulses propagating down a drill string according to the invention.

[0018] Further aspects and advantages of the
20 invention are described below and shown in the accompanying drawings.

Brief Description of the Drawings

[0019] In drawings which illustrate various non limiting embodiments of the invention: Figure
5 1A is a schematic view of a typical classic rotary drilling method apparatus, with a surface acoustic pulse generator (SAP generator) pursuant to one embodiment of the invention;

Figure 1B is an enlarged schematic diagram of
10 the SAP generator of Figure 1A;

Figure 2A is a schematic view of a typical classic rotary drilling apparatus, with an SAP generator pursuant to an alternative embodiment of the invention;

15 Figure 2B an enlarged schematic diagram of the SAP generator of Figure 2A;

Figure 3A is a schematic view of a typical classic rotary drilling method apparatus, with an SAP generator pursuant to a further alternative
20 embodiment of the invention;

Figure 3B an enlarged schematic diagram of the SAP generator of Figure 3A;

Figure 4 is a schematic view of a typical classic rotary drilling method apparatus equipped
25 with an SAP generator pursuant to a further alternative embodiment of the invention;

Figure 5A is a schematic view of the SAP generator of Figure 4 and a schematic view of a preferred interrupter valve means pursuant to the
30 invention;

Figure 5B is an enlarged schematic diagram of the preferred interrupter valve means of Figure 5A;

Figure 5C is a detailed schematic diagram of the preferred interrupter valve means of Figure 5A;

FIG 6 is a schematic view of drilling apparatus including an acoustic pulse generator and a
5 multiple piston telescopic tool located in a drill string above a drill bit;

FIG 7 is a longitudinal sectional view of the down hole telescopic tool of Figure 6 shown in its "closed" position;

10 FIG 8 is a longitudinal sectional view of the down hole telescopic tool of Figure 7 shown in its "open" position;

FIG 9 is a cross sectional view through a splined part of the telescopic tool of Figure 8;

15 FIG 10 is a schematic view of a drilling apparatus including a surface acoustic pulse generator and a multiple piston telescopic (MPT) tool in the drill string above one or a few drill collars;

20 FIG 11 is a longitudinal sectional view of the MPT tool in a first position wherein the weight of the portion of the drill string below the tool is supported by a set of springs; and,

25 FIG 12 is a longitudinal sectional view of the MPT tool of Figure 11 in a second position which occurs when a pressure pulse lifts the portion of the drill string below the MPT tool.

Detailed Description

30 [0020] As required, detailed embodiments of the present invention are disclosed herein. However, it is to be understood that the disclosed embodiments

are merely exemplary of the invention, which may be embodied in various forms. Therefore, specific structural and functional details disclosed herein are not to be determined as limiting, but merely as
5 a basis for the claims and a representative basis for teaching one skilled in the art to variously employ the present invention in virtually any appropriately detailed structure.

10 [0021] This invention provides methods for generating acoustic pulses at the surface and conveying such pulses downhole to downhole tools and/or a drill bit. In preferred embodiments of the invention, acoustic pulses are generated by
15 interrupting the flow of drilling mud in a conduit and thereby causing water hammer in the conduit.

[0022] Figure 1A is a schematic view of a typical rotary drilling apparatus 10 which has been
20 modified by the addition of a surface acoustic pulse generator (SAP generator) 20 according to the invention. Figure 1B is a detailed schematic view of SAP generator 20. Rotary drilling apparatus 20 comprises a mud pump 45 which pumps drilling mud 21
25 from a mud tank 32 into a stand pipe 22. Pump 45 typically has a relatively high capacity and supplies mud 21 under significant pressure. The pressure within stand pipe 22 might be, for example, 2,500 psi. Stand pipe 22 delivers mud to
30 the drill string in any suitable way.

[0023] In the illustrated embodiment, stand pipe 22, is fastened to a derrick 23, located on a surface of an area to be drilled. A flexible hose 43 (made for example of reinforced rubber) carries the flow of drilling mud 21 from stand pipe 22 into a swivel 24, which is suspended from derrick 23 by a hook. From swivel 24, drilling mud 21 enters a drilling pipe 27 by passing through a kelly cock 25 and then a kelly 26. Drilling mud 21 is conveyed to a drill bit 30 by way of a number of vertically successive drill collars 28, and a bit sub 29. The drilling fluid exits bit 30 through a number of openings. Drilling mud 21 then returns to the surface through the annular well bore 31 surrounding the drill string. At the surface the mud is collected and returned to mud tank 32. The mud may be treated to remove cuttings etc. after it is collected.

[0024] Kelly 26 is typically rotated by a rotary table 33. The rotation of kelly 26 is imparted to drill pipe 27, successive drill collars 28, bit sub 29 and drill bit 30. In some cases the drill string may be rotated by a top drive (not shown). In such cases a kelly is not needed. As shown in Figure 1A, SAP generator 20 is preferably installed between mud pump 45 and stand pipe 22.

[0025] As shown in detail in Figure 1B, some of pressurized drilling mud 21 is diverted at a junction 145 into a conduit 52 as indicated by arrow 53. Conduit 52 is preferably made from heavy

5 wall pipe. The amount of drilling mud diverted into
conduit 52 can be adjusted by a flow control valve
48. In preferred embodiments of the invention the
proportion of drilling mud which is diverted at
10 junction 145 is significantly smaller than the
proportion of drilling mud in the main flow which
continues past junction 145 into stand pipe 22. In
the illustrated embodiment, flow control valve 48
comprises a needle valve. The flow in conduit 52
15 can be adjusted by turning valve stem 49 with knob
50. Valve stem 49 is in threaded engagement 51 with
the housing of flow control valve 48. Therefore,
rotation of valve stem 49 causes valve stem 49 to
move axially, thereby altering the degree to which
20 valve stem 49 restricts the flow of fluid into
conduit 52. Suitable seals are provided to prevent
leakage of mud around valve stem 49.

[0026] A substantial portion of the drilling mud
20 diverted at junction 145 eventually flows back into
mud tank 32 (the two mud tanks 32 illustrated in
each of Figures 1A and 1B may be different mud
tanks but are preferably the same mud tank). SAP
generator 20 includes a flow interrupting valve 54
25 operated by a valve controller 55 which causes
valve 54 to periodically at least substantially
block the flow of drilling mud 21 out of conduit
52. A currently preferred embodiment of interrupter
valve controller 55 according to this invention is
30 described below with reference to Figures 5A
through 5C.

[0027] Valve controller 55 may comprise any of a wide variety of valve control means. By way of example only, possible valve control means include:

- 5 • electrically operated valve actuators driven by electrical or electronic controllers;
- hydraulic or pneumatic control circuits;
- valve members in valve 54 actuated by flow of mud through valve 54; and,
- 10 • mechanical valve operating mechanisms comprising cams, reciprocating members, oscillating members, or the like which move a valve member in a valve 54 to periodically interrupt the flow of drilling mud through valve 54.

15

[0028] When valve 54 is not blocking the flow of drilling mud, the drilling mud flows through valve 54 and out of port 44. By rapidly blocking the flowing drilling mud in conduit 52, flow
20 interrupting valve 54 generates water hammer pulses which propagate upstream in conduit 52.

[0029] A pulse transmission means, which is a conduit 56 in the illustrated embodiment, has one
25 end connected to conduit 52 at a location upstream from interrupter valve 54. Another end of pulse transmission conduit 56 joins main conduit 57, which carries the main flow of drilling mud 21 to stand pipe 22. In preferred embodiments of the
30 invention, a check valve 47 prevents drilling mud from flowing back through pulse transmission conduit 56 into conduit 52. Check valve 47 opens to

allow drilling mud to flow through conduit 56 in the direction of arrow 56A only under the high pressure water hammer pulses generated by the sudden closing of valve 54.

5

[0030] Water hammer induced pressure pulses in conduit 52 are transmitted by pulse transmission conduit 56 into main conduit 57 where they continue to propagate downstream into the drill string. As
10 the bore of the drill string is typically smaller than the bore of conduit 57 and other conduits through which the mud passes at the surface, the intensity of the pulses increases as the pulses pass into the smaller diameter bore of the drill
15 string. The pulses may be applied at underground locations to enhance drilling performance as described below. Pulses may also be transmitted upstream toward pump 45. A pulsation dampener 147 may be provided in main line 57 downstream of pump
20 45 and upstream of pulse transmission conduit 56 to reduce the effect of SAP generator 20 on the operation of pump 45.

[0031] A shut off valve 46 and check valve 47
25 allow users to isolate SAP generator 20 from the main flow of drilling mud 21 while drilling operations are ongoing. By disconnecting SAP generator 20, drilling/penetration rates with and without SAP generator 20 can be compared. Further,
30 the operating parameters of SAP generator 20 can be adjusted during drilling operations to optimize the performance of the drilling rig.

[0032] During operation of the apparatus, some drilling mud 21 flows in the direction of arrow 53 through flow control valve 48 into conduit 52 toward interrupter valve 54. Valve controller 55 causes valve 54 to repeatedly open for a time long enough for a flow of drilling mud to be established in conduit 52 and then close relatively suddenly. Each time this sequence of events occurs a water hammer pulse is generated in conduit 52. The sudden closure of interrupter valve 54 causes kinetic energy of the mud flowing in conduit 52 to be converted into a high pressure acoustic pulse. The intensity of the acoustic pulse increases in proportion to the velocity of the mud flow in conduit 52 approximately according to the equation:

$$\Delta p = \rho \times V_s \times V \quad (1)$$

20 where Δp = pressure increase due to water hammer;
 ρ = specific mass of drilling mud;
 V_s = velocity of sound in drilling mud; and,
 V = velocity of mud flow in conduit 52.

25 Further details on the mathematics and physical effects of water hammer can be found in various texts on fluid mechanics, including Victor L Streeter and E. Benjamin Wylie's *Fluid Mechanics* (7th edition), McGraw Hill Book Company (1979).

30 [0033] Water hammer pressure pulses resulting from the sudden closures of valve 54 travel upstream from closed valve 54, at the velocity of the speed

of sound in the drilling mud inside conduit 52. This pressure pulse also propagates into conduit 56. Check valve 47 opens and allows the pressure pulse to propagate into main flow conduit 57. The
5 pressure pulses travel at the speed of sound in the drilling mud through stand pipe 22 and down through the drill string to drill bit 30. The pressure pulses cause oscillations in the flow of drilling mud exiting through the nozzles of drill bit 30.
10 This enhances cleaning of the bottom of well bore 34 and helps to achieve improved drilling penetration rates.

[0034] Figure 2A is a schematic view of a drill
15 rig according to an alternative embodiment of the invention comprising an alternative SAP generator 35. In this embodiment, drilling mud exiting from SAP generator 35 is returned to the main flow of drilling mud in conduit 57. The construction of SAP
20 generator 35 is shown in detail in Figure 2B. A venturi 37 is provided in main conduit 57. Venturi 37 acts as a jet pump. The pressure within main conduit 57 is reduced at point 59, which is in a volume adjacent to venturi 37. The volume may
25 comprise an annular region surrounding venturi 37. Mud exiting from down stream port 44 of interrupter valve 54 is returned to main partial flow of drilling mud 53 at point 59. The pressure difference between junction 145 at which drilling
30 mud flows into SAP generator 35 and point 59 drives the flow of drilling mud through SAP generator 35. SAP generator 35 functions otherwise in the same

manner as the SAP generator 20 described above. High intensity acoustic pulses are delivered into main conduit 57 at point 40. A valve 58 is provided to facilitate isolating SAP generator 35 from main
5 conduit 57. It should be noted that entry of the acoustic pulse can be also incorporated down stream into the venturi arrangement 37.

[0035] SAP generator 35 provides the advantages
10 that it permits better monitoring of the drilling mud flow and of mud loss in the well bore. It further allows more flexibility in terms of installation. It should be noted that SAP generator 35 may be constructed so that the acoustic pulses
15 are coupled to main conduit 57 at a point in the venturi arrangement down stream from venturi 37.

[0036] Figures 3A and 3B show an alternative SAP generator 41 pursuant to an alternative embodiment
20 of this invention. SAP generating circuit 41 is incorporated into a tool 42, which is placed below swivel 24. Tool 42 is preferably placed above kelly cock 25 and kelly 26. SAP generator 41 operates similarly to SAP generator 35, but introduces
25 pulses directly into the drill string. The pulses do not need to travel through flexible hose 43. All other things being equal, SAP generator 41 should produce pulses of higher intensity at drill bit 30 than the embodiments described above. Venturi
30 arrangement 37 is incorporated into a lower tool body 64. A top tool sub 65 has a conduit 60 that allows a portion of the main flow of drilling mud

21 to enter SAP generator 41. Interrupter valve 54
can be a self regulating valve operated by the
water hammer itself as is described in US patent
No. 5, 549, 255 (Walter), at Figures 8 and 9 which
5 is incorporated herein by reference.

[0037] The main advantage of SAP generator 41 is
that generated acoustic pulses are inserted
directly into the drill string and do not have to
10 travel through rubber hose 43, which may tend to
somewhat attenuate the pulses. The main
disadvantage is that it is not as easily accessible
for servicing and adjustment as SAP 20 or SAP 35.

15 [0038] Figure 4 shows an alternative SAP generator
135 pursuant to an alternative embodiment of this
invention. SAP generator 135 is similar to SAP
generator 20, save for the fact that it lacks a
pulse transmission conduit 56 and check valve 47.
20 Pressure pulses generated by the sudden closure of
interrupter valve 54 travel upstream from valve
54 and enter main conduit 57 at junction 145.

[0039] SAP generator 135 has an additional flow
25 control valve 148 located between down stream port
44 of interrupter valve 54 and mud tank 32. Second
flow control valve 148 allows the back pressure on
valve 54 to be adjusted. Depending upon the
construction of valve 54, the performance of valve
30 54 may be adjusted by altering the back pressure.

[0040] The SAP generator 135 of Figure 4 has the advantage of simplicity. Flow control valves 48 and 148 can be adjusted so that just enough drilling mud flows through SAP generator 135 when valve 54 is open to reduce the flow and pressure in main conduit 57 downstream from junction 45.

[0041] When valve 54 is opened some drilling mud is diverted through valve 54. A reduced pressure (in some cases zero pressure) pulse propagates downstream through the drilling mud from point 145. The pressure pulse affects the pressure at jet nozzles in bit 30. When valve 54 is subsequently closed, a water hammer is generated upstream from valve 54. When the water hammer reaches point 145 mud is no longer diverted toward valve 54 and all of the mud flowing in the upstream portion of conduit 57 must be carried downstream from point 145 by conduit 57. The pressure at point 145 increases until the mud flowing at locations downstream from point 145 is accelerated. The resulting pressure pulse propagates downstream to affect the pressure at jet nozzles in bit 30.

[0042] Figure 5A shows a drill rig including a SAP generator 135 in which valve 54 and valve controller 55 are provided by an interrupter mechanism 120. Interrupter mechanism 120 can be used to advantage in any of the SAP generators described above. Figures 5B and 5C are more detailed views of interrupter mechanism 120.

[0043] Interrupter mechanism 120 comprises a valve member 127 which bears against a valve seat 127A. Valve member is biased into a closed position by a spring 128. An air bladder 129
5 contains compressed air (which can be supplied through a port 125). Air bladder 129 applies forces to valve member 127 which tend to move valve member 127 into an open position wherein drilling mud can flow from an inlet chamber 122 between valve member
10 127 and valve seat 127A into an outlet chamber 123. Drilling mud can enter inlet chamber 122 through inlet passage 121. Drilling mud can leave outlet chamber 123 through outlet passage 124.

15 [0044] In operation, compressed air is admitted into bladder 129 until valve member 127 is moved into its open position against the force exerted by spring 128. As soon as this occurs, drilling mud begins to flow from inlet chamber 122 to outlet
20 chamber 123. As drilling mud begins to flow through downstream choke valve 148 a back-pressure is developed. This back pressure, combined with the forces exerted on valve member 127 by flowing fluid cause valve member 127 to move into its closed
25 position. The closure of valve member 127 causes a water hammer pulse to propagate upstream from input chamber 121. Valve member 127 is maintained in its closed position by the pressure pulse (and underlying static pressure). When the pressure
30 pulse reaches main conduit 57, or another place where fluid can flow to relieve pressure, a negative pulse propagates back toward interrupter

mechanism 120. Upon arrival of the negative pulse, valve member 127 is pulled open and the cycle repeats itself.

5 [0045] An advantage of interrupter mechanism 120 is that it can be constructed in a robust manner and the frequency of generated pulses can be easily and continuously changed. The operation of mechanism 120 can be adjusted by varying the air
10 pressure in bladder 129 and varying the settings of downstream choke valve 148 and valve 48.

[0046] An accumulator 146 may be provided upstream from interrupter mechanism 120 to increase
15 the duration of acoustic pulses. In general this is not required and has the disadvantage of reducing the intensity of the acoustic pulses propagated down the drill string.

20 [0047] In the foregoing embodiments of the invention, intense acoustic pulses are generated at the surface by a SAP generator. The pulses are introduced into the drilling mud which is flowing down the drill string. The pulses propagate down
25 the drill string to the bit. At the bit the pulses cause variations in the mud flow which can increase the efficiency of the drilling operation. The intense acoustic pulses (positive and/or negative) can also be used to actuate downhole tools. The
30 tools can be of simple robust construction. One class of tools that may be actuated by acoustic pulses according to the invention includes tools

which impart mechanical vibration to the drill bit. Such tools may suddenly force the drill bit downwardly upon the arrival of a pulse at the tool. In the alternative, such tools may lift a lower
5 portion of the drill string slightly in response to the arrival of a pulse and then drop the lower portion of the drill string after the pulse has passed. Other types of tools such as drilling jars may also be actuated by the acoustic pulses of the
10 invention.

[0048] Figure 6 is a schematic view of a rotary drilling apparatus which includes a multiple piston telescopic tool 66 mounted in the drill string
15 above drill bit 30. Pulses generated by SAP generator 35 are conveyed down through the drill string as described above. When the pulses reach multiple piston telescopic tool 66 the tool extends slightly, thereby accelerating the drill bit into
20 the formation being drilled. This embodiment of the invention can significantly vibrate the entire drill string 67, thus reducing friction between drill string 67 and well bore 68. The vibration of drill bit 30 also enhance percussive action of
25 drill bit 30 at the bottom of hole 34, resulting in faster drilling and lower torque requirements.

[0049] Figures 7 and 8 show a longitudinal sectional view of a multiple piston telescopic tool
30 66 in normal and extended positions respectively. Tool 66 is coupled to a bottom end of a section of one drill collar 28 via a coupling which, for

example comprises a conventional threaded coupling 95. Tool 66 includes a ram 69 which is coupled to drill bit 30 at a connection 70. Connection 70 may be a conventional threaded coupling. Ram 69 bears
5 splines 96 and is received within a female-splined member 89 as shown in Figures 8 and 9. Splines 96 provide a torque coupling between female splined member 89 and ram 69. Ram 69 can therefore slide longitudinally within the body of tool 66 without
10 interrupting the transmission of rotational motion to drill bit 30. A top end of ram 69 is coupled to a pair of pistons 72, 74. Ram 69 and pistons 72 and 74 can move longitudinally in tool 66 as a unit. The arrival at tool 66 of a pressure pulse
15 propagating through the drilling mud in bore 79 forces pistons 72 and 74 downwardly. This, in turn, causes ram 69 to move from the normal position shown in Figure 7 to the extended position shown in Figure 8.

20

[0050] In the illustrated tool 66 each of pistons 72 and 74 is slidably disposed within a housing. Piston 72 is disposed within housing 90. Piston 74 is disposed within a housing 91. Housing 90 is
25 coupled to housing 91 by a suitable coupling, such as threaded coupling 92. Housing 91 is coupled to a top sub 93 at a suitable coupling, such as threaded coupling 94. Housing 90 is coupled to female-splined member 89 which receives ram 69 by
30 a suitable coupling such as a threaded coupling 91A.

[0051] Each piston is located between a pair of cavities. Cavities 77 and 78 are upwardly adjacent to pistons 72 and 74 respectively. Cavities 77 and 78 are each in fluid communication with bore 79. In
5 the illustrated embodiment apertures 81 and 82 are provided for this purpose. Cavities 83 and 84 are downwardly adjacent to pistons 72 and 74 respectively. Cavities 83 and 84 are each in fluid communication with the well bore 31 outside of tool
10 66. In the illustrated embodiment apertures 85 and 86 are provided for this purpose.

[0052] A cavity 76 is also defined between the upper end of ram 69 and housing 90. This cavity is
15 in fluid communication with bore 79, for example by way of apertures 80. Shaft seals 87 and piston seals 88 seal cavities 76, 77 and 78.

[0053] The number of pistons may be varied. One or
20 more pistons may be used. Preferably two or more pistons are provided. An additional piston may be added simply by coupling a piston like piston 72 between pistons 72 and 74 and a housing like housing 91 between housings 91 and 92.

25
[0054] Figure 7 shows multiple piston telescopic tool 66 when no acoustic pressure pulse is present and tool 66 is in its closed position. When a pressure pulse propagating down bore 79 reaches
30 area 97, the pressure of drilling mud in area 97 is suddenly increased. This causes drilling mud to be forced into cavities 76, 77 and 78 via apertures

80, 81 and 82 respectively. The increased pressure within cavities 76, 77 and 78 acting on projected piston areas results in an axial force on ram 69. This force drives ram 69, and drill bit 30, into the bottom of hole surface 34. For example, a pressure pulse of 1,500 psi acting on total area of 80 in² will produce an axial force of 120,000 lbs. This axial force will cause drill bit 30 to be thrust against the bottom of hole 34, while reaction to this axial force will lift the part of the drill string situated above multiple piston telescopic tool 66. Relative telescopic movement is indicated by "E" on Figure 8. When the pressure pulse has passed the weight of the drill string above multiple piston telescopic tool 66 will cause tool 66 to collapse back into its normal position and thereby closing gap E. The dropping drill string will also deliver additional impact forces applied to drill bit 30.

20

[0055] Figure 10 is a schematic view of a drilling rig according to an alternative embodiment of this invention. In the apparatus of Figure 10, high pressure pulses generated at SAP generator 35 are conveyed down the drill string through a multiple piston telescopic tool 98, mounted above one or more lower drill collars 99, and attendant bit sub 29 and drill bit 30. This embodiment provides for vigorous axial vibration of the bottom part of the drill string, allowing in some instances to drill percussively without need for a classical drill bit 30.

25

30

[0056] Figures 11 and 12 show a longitudinal sectional view of a multiple piston telescopic tool 98. A bottom part of tool 98, identified by "L", is similar to the multiple piston telescopic tool 66 shown in Figures 7 and 8, except that:

- bottom part L is adapted to be coupled to a top section of a lower drill collar 99. In the illustrated embodiment, ram 69A in bottom part L comprises a male thread 100, which can be screwed to drill collar 99.
- cavities 76, 77 and 78 are in fluid communication with outside well bore 31 instead of bore 79. In the illustrated embodiment, holes 101 are provided for this purpose.
- cavities 83 and 84 are in fluid communication with inside bore 79 instead of outside well bore 31. In the illustrated embodiment, holes 103 are provided for this purpose.

[0057] A top part of tool 98 comprises a spring housing 104, which is coupled to a third piston housing 114 via threaded connection 105. Piston 74 comprises a piston mandrel extension 106 which extends into spring housing 104. A spring is connected between spring housing 104 and mandrel extension 106. The spring has a very large spring constant. The spring is compressed whenever the piston mandrel extension 106 moves longitudinally upwardly or downwardly inside spring housing 104. In the illustrated embodiment, a stack of disk

5 springs 107 is on mandrel extension 106 between washers 109A and 109B. Washer 109A abuts a step in the outside of mandrel extension 106. Washer 109B abuts the bottom of a top sub 111 which is coupled to spring housing 104 via threaded connection 112.

10 [0058] Ram 69A and other parts of the drill string below tool 98 are supported by a safety nut 108. Safety nut 108 is locked in place by a screw 110. Tool 98 is coupled to the drill string at its top end via a threaded connection 113.

15 [0059] Figure 12 shows multiple piston telescopic tool 98 when the pressure within bore 102 is at its low or zero value. Figure 13 shows multiple piston telescopic tool 98 when a high pressure pulse has propagated down the drill string and is passing through bore 102 of tool 98. The pressure pulse increases the pressure of drilling mud in bore 102 and causes drilling mud to be forced into cavities 20 83 and 84. This causes a force to act on pistons 72 and 74 so as to drive the pistons upwardly. When the pistons move upwardly the portion of the drill string located below tool 98 is also lifted upwardly and spring 107 is compressed. After the 25 effect of the pressure pulse has dissipated, loaded stack of disk springs 107 will dynamically return bottom part L of tool 98 to its initial position, thus resulting in a significant percussive blow to 30 bottom hole 34.

[0060] For example, a pressure pulse of 1,500 psi multiplied by a combined piston area of 60 in² will produce an axial lifting force of 90,000 lbs. In a typical drilling apparatus the weight of lower
5 drill collars 99, and other elements (such as drill bit 30) located below multiple piston telescopic tool 98, is approximately 3,000 - 6,000 lbs. Spring 107 will therefore elastically absorb the resultant axial force and return bottom end of the drill
10 string with such a force so as to produce extreme percussive blows to bottom hole 34. These percussive blows can enhance drilling penetration rates, particularly when the formation being drilled is hard.

15

[0061] Figure 13 illustrates schematically another simple tool which may be used to impart vibration to a drill bit. Tool 200 comprises a splined ram 202 which is slidably disposed within
20 a female-splined part 204. Ram 202 is coupled to a drill bit. Female splined part 204 is coupled to the upper portion of the drill string. A diameter of bore 79 is reduced at or in ram 202. Ram 202 thereby presents an upwardly facing surface 208.
25 When a pressure pulse propagating down bore 79 increases the pressure acting on surface 208 ram 202 (and the drill bit) are hammered downwardly.

[0062] As will be apparent to those skilled in the
30 art in the light of the foregoing disclosure, many alterations and modifications are possible in the

practice of this invention without departing from the spirit or scope thereof. For example:

- 5 • While the foregoing description details the generation of high intensity pulses by interrupting the flow of the drilling mud pressurized by mud pump 45 a separate pump could be used to provide flowing drilling mud for use in generating high pressure pulses.
- 10 • While the flowing fluid medium which is used to generate high pressure pulses is described above as being drilling mud, a separate circuit in which high pressure pulses are developed by creating water hammers in a different fluid medium, such as water, could be used to generate high pressure pulses which are then coupled into the drilling mud being pumped down drill string.
- 15 • Other techniques could be used for generating high pressure pulses which are propagated down through the drill string. For example, a piston capable of being very suddenly accelerated could be located to transmit high intensity pulses into the flowing drilling mud 57. The piston could be on a very high energy
20 electromechanical transducer, for example.
- 25 • Other types of tool such as drilling jars may be constructed so as to be operable by high intensity pulses propagated from the surface according to the invention.

[0063] Accordingly, the scope of the invention is to be construed in accordance with the substance defined by the following claims.

CLAIMS:

1. A method for underground drilling, the method comprising:
 - 5 a) generating high intensity pressure pulses at the surface of an area to be drilled;
 - b) coupling the high intensity pressure pulses into drilling mud being pumped into a drill string so that the high intensity pressure pulses propagate
10 down the drill string to an underground location; and,
 - c) doing work at the underground location with the high intensity pressure pulses,
15 wherein generating the high intensity pressure pulses comprises causing drilling mud to flow in a first conduit and suddenly and periodically interrupting the flow of drilling mud in the first conduit.
- 20 2. The method of claim 1 wherein the work comprises causing a flow of drilling fluid through nozzles in a drill bit at the bottom of the drill string to fluctuate.
- 25 3. The method of claim 1 wherein the work comprises operating a downhole tool.

4. The method of claim 3 wherein operating the downhole tool comprises forcing a portion of the drill string which includes a drill bit suddenly downwardly.
- 5 5. The method of claim 3 wherein operating the downhole tool comprises lifting a portion of the drill string which includes a drill bit upwardly and compressing a spring.
- 10 6. The method of claim 1 wherein causing drilling mud to flow in the first conduit comprises diverting a portion of a main flow of drilling mud from a mud pump to the drill string into the first conduit.
- 15 7. The method of claim 6 comprising returning mud which has flowed through the first conduit to a mud tank.
8. The method of claim 6 comprising providing a point at which a hydrostatic pressure of drilling mud flowing
20 toward a drill string in a main conduit is reduced and introducing mud which has flowed through the first conduit into the main conduit at the point of reduced pressure.
- 25 9. The method of claim 8 wherein providing the point at which hydrostatic pressure is reduced comprises providing a jet pump and causing drilling mud flowing in the main conduit to pass through the jet pump.

10. The method of any of claims 1 to 9 practised on a drilling rig having a drill string suspended from a swivel and a flexible hose carrying drilling mud into the swivel for passage down the drill string and
5 coupling the high intensity pressure pulses into drilling mud being pumped into a drill string is performed upstream from the flexible hose.
11. The method of any of claims 1 to 9 practised on a
10 drilling rig having a drill string suspended from a swivel and a flexible hose carrying drilling mud into the swivel for passage down the drill string and coupling the high intensity pressure pulses into drilling mud being pumped into a drill string is
15 performed downstream from the swivel.
12. A method for underground drilling, the method comprising:
- 20 a) generating high intensity pressure pulses at the surface of an area to be drilled;
- b) coupling the high intensity pressure pulses into drilling mud being pumped into a drill string;
- c) allowing the high intensity pressure pulses to propagate down the drill string to an underground
25 location; and,
- c) allowing the high intensity pressure pulses to do work at the underground location.

13. The method of claim 12 wherein the work comprises causing a flow of drilling fluid through nozzles in a drill bit at the bottom of the drill string to fluctuate.

5

14. The method of claim 12 wherein the work comprises operating a down hole tool.

10

15. The method of claim 14 wherein operating the downhole tool comprises forcing a portion of the drill string which includes the drill bit suddenly downwardly.

15

16. The method of claim 14 wherein operating the downhole tool comprises lifting a portion of the drill string which includes the drill bit upwardly and compressing a spring.

20

17. The method of any one of claims 12 to 16 wherein generating the high intensity pressure pulses comprises causing drilling mud to flow in a conduit and suddenly and periodically interrupting the flow of drilling mud in the conduit.

25

18. The method of claim 17 wherein causing drilling mud to flow in a conduit comprises diverting a portion of a main flow of drilling mud from a mud pump to the drill string into the conduit.

19. The method of claim 18 comprising returning mud which has flowed through the conduit to a mud tank.
- 5 20. The method of claim 18 comprising providing a point at which a hydrostatic pressure of drilling mud flowing toward a drill string in a main conduit is reduced and introducing mud which has flowed through the conduit into the main conduit at the point of reduced pressure.
- 10 21. The method of claim 20 wherein providing a point at which a hydrostatic pressure of drilling mud flowing toward a drill string in a main conduit is reduced comprises providing a jet pump and causing drilling mud flowing in the main conduit to pass through the jet
15 pump.
22. The method of any of claims 12 to 21 practised on a drilling rig having a drill string suspended from a swivel and a flexible hose carrying drilling mud into
20 the swivel for passage down the drill string and coupling the high intensity pressure pulses into drilling mud being pumped into a drill string is performed upstream from the flexible hose.
- 25 23. The method of any of claims 12 to 21 practised on a drilling rig having a drill string suspended from a swivel and a flexible hose carrying drilling mud into the swivel for passage down the drill string and

coupling the high intensity pressure pulses into drilling mud being pumped into a drill string is performed downstream from the swivel.

- 5 24. Underground drilling apparatus comprising:
- a) a drill string;
 - b) a mud pump;
 - c) a main conduit carrying mud pumped by the mud pump toward the drill string;
 - 10 d) pulse generator means located at the surface for generating high intensity pressure pulses;
 - e) pulse transmission means for coupling high intensity pressure pulses generated by the pulse generator means into mud being pumped toward the
 - 15 drill string.
25. A downhole tool described herein.
26. A method practiced in using a downhole tool as
- 20 described herein.
27. Apparatus for underground drilling as described herein.



INVESTOR IN PEOPLE

37

Application No: GB0507206.1

Examiner: Alan Jones

Claims searched: 1-27

Date of search: 6 May 2005

Patents Act 1977: Search Report under Section 17

Documents considered to be relevant:

Category	Relevant to claims	Identity of document and passage or figure of particular relevance
X,Y	X: 12, 14, 15 & 24-27, Y: 16	OA06683 A (RUDOLF HAUSHERR & SOHNE) See e.g. page 2 line 29 - page 3 line 3
X	12, 14, & 22-27	US5950736 A (GOLDSTEIN) See whole document
X	12-14, 24-27	EP0406492 A1 (BODINE) See e.g. col. 4 line 51 - col. 5 line 6 & figure 2
X	12, 22 & 23	US3507341 A (BASGAN) See e.g. figure 1 & col. 5 line 48 - col. 6 line 17
Y	16	GB2345931 A (BAKER HUGHES INC) See e.g. spring mechanism 78

Categories:

X	Document indicating lack of novelty or inventive step	A	Document indicating technological background and/or state of the art.
Y	Document indicating lack of inventive step if combined with one or more other documents of same category.	P	Document published on or after the declared priority date but before the filing date of this invention.
&	Member of the same patent family	E	Patent document published on or after, but with priority date earlier than, the filing date of this application.

Field of Search:

Search of GB, EP, WO & US patent documents classified in the following areas of the UKC^X :

EIF

Worldwide search of patent documents classified in the following areas of the IPC⁰⁷

E21B

The following online and other databases have been used in the preparation of this search report

Online: WPI, EPODOC