

(21) Application No: 1422581.7

(22) Date of Filing: 18.12.2014

(71) Applicant(s):
Invisifold Ltd
Hamble Court, Hamble Lane, SOUTHAMPTON,
Hampshire, SO31 4QJ, United Kingdom

(72) Inventor(s):
Stephen Smith
Neil Ingram

(74) Agent and/or Address for Service:
Handsome I.P. Ltd
3 Chapel Row, Queen Square, BATH, BA1 1HN,
United Kingdom

(51) INT CL:
E05D 15/48 (2006.01) **E05D 15/06** (2006.01)
E05D 15/58 (2006.01) **E06B 3/46** (2006.01)

(56) Documents Cited:
EP 1892362 A1 **EP 1496182 A2**
WO 2011/135131 A1 **US 5749172 A**
US 3654732 A **US 20140326419 A1**
US 20110088326 A1 **US 20050229512 A1**

(58) Field of Search:
 INT CL **E05D**
 Other: **Online: EPODOC TXTA WPI**

(54) Title of the Invention: **A window**
 Abstract Title: **Sliding and pivoting window assembly**

(57) A window assembly comprising a plurality of windows 30A-30C at least one window having upper and lower sliding hinges (50) and a least one guide element (56, fig.7) for sliding along upper and lower guide channels in a frame; the guide element disengaging from the channel to allow pivoting of the window. The guide element may be retractable, alternatively a slot or gap 92, 94 in the channel wall allows escape of guide element. The hinge may comprise a rectilinear block 72 constrained for sliding and a pivotal portion having quadrant shape 76 partially extending out of hinge slot 62, 63 in guide channel wall 82 when rotated; the guide channel may be narrower at region of rotation with landing strip (90, fig.7) having narrower walls and ramp surface cooperating with sliding block 72

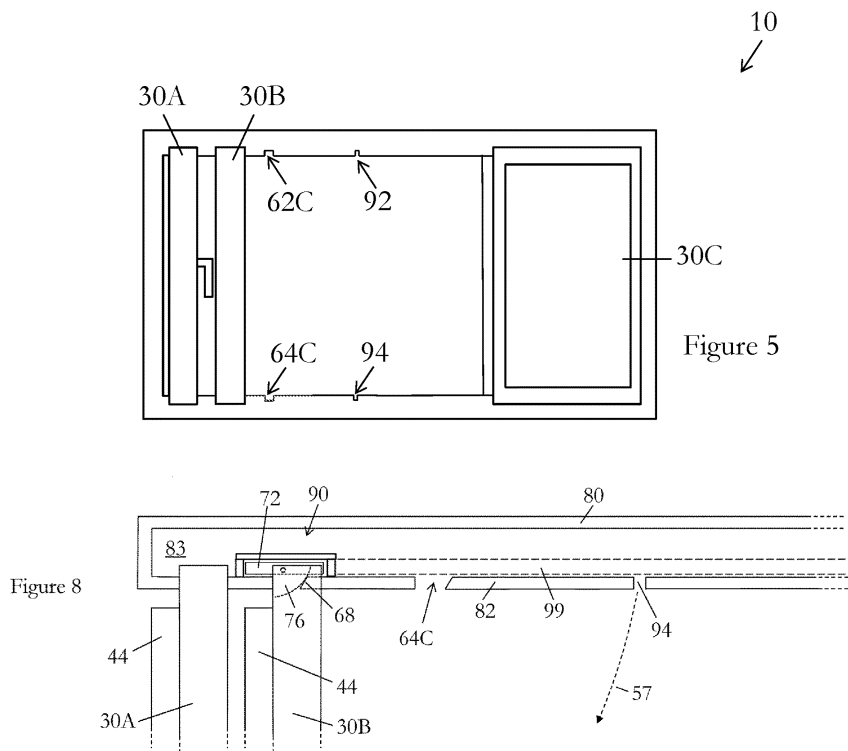

1/4

10

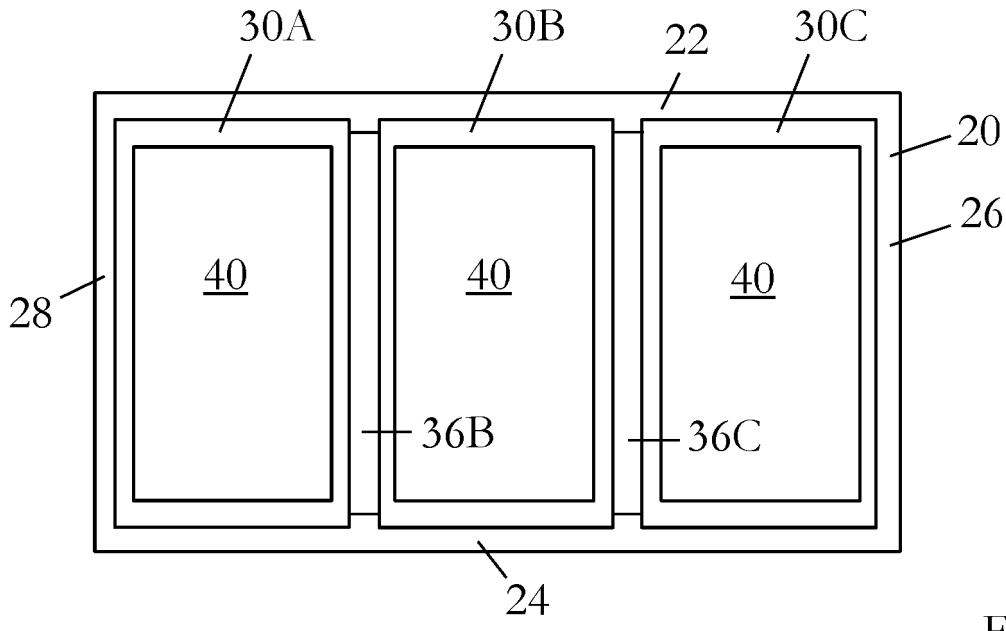

Figure 1

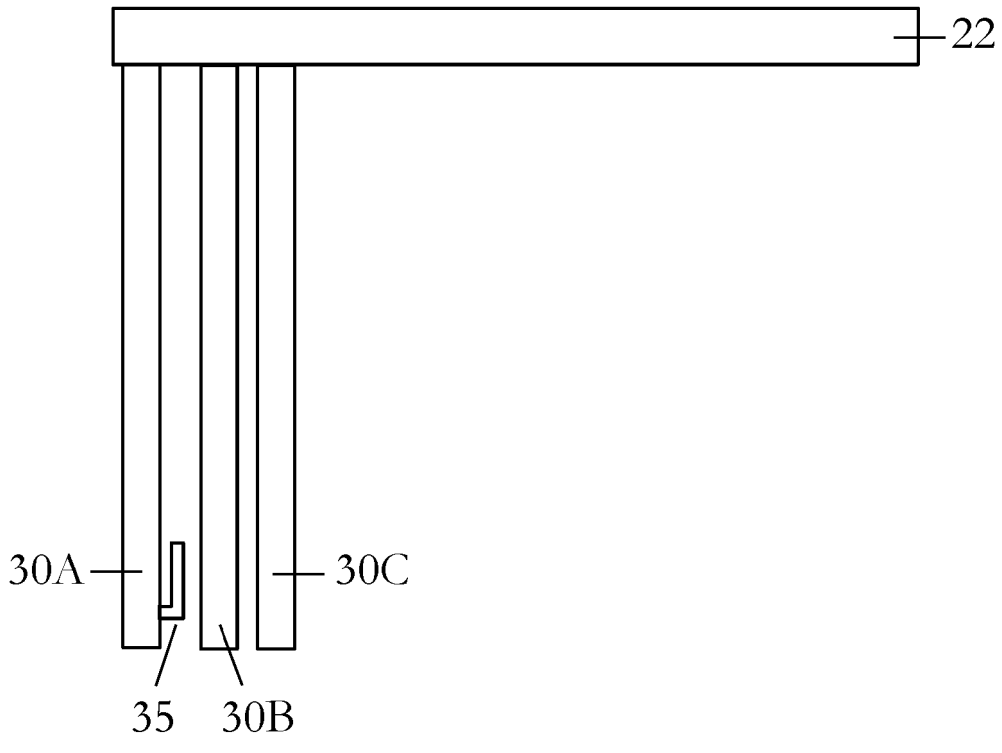

Figure 2

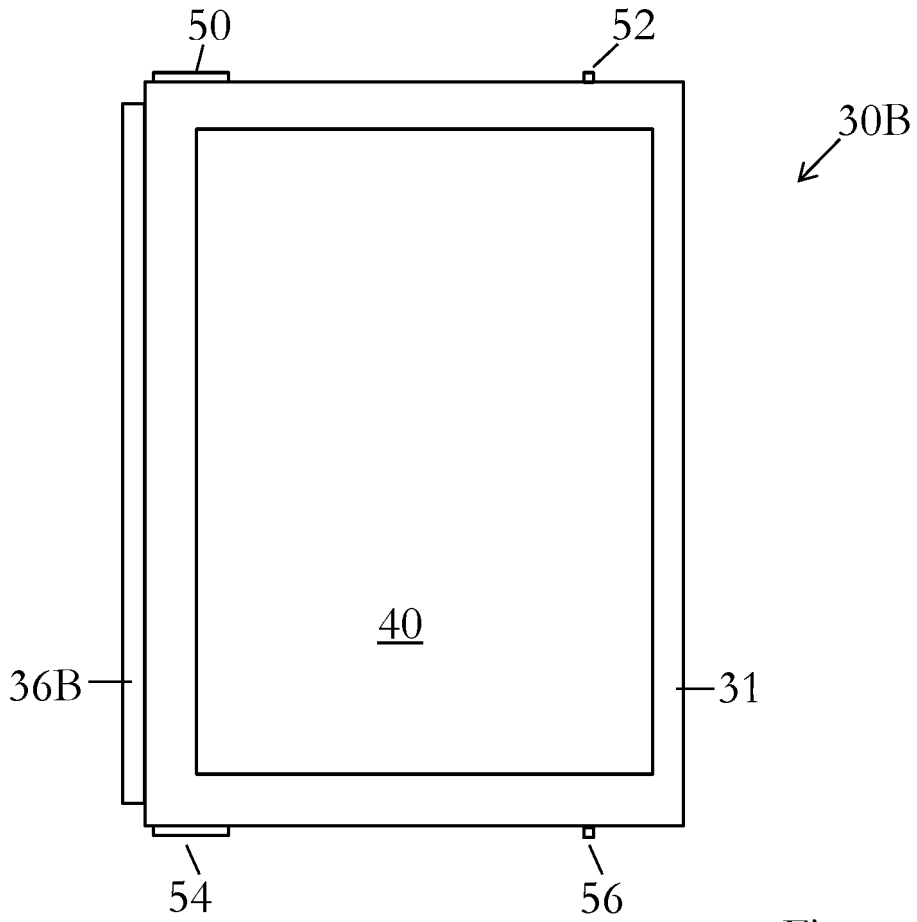

Figure 3

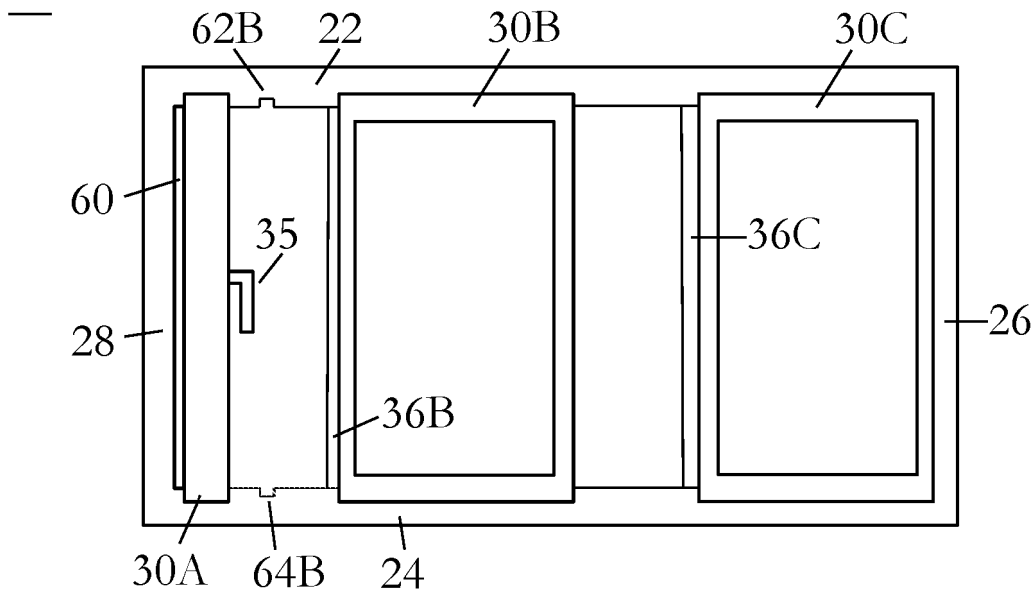

Figure 4

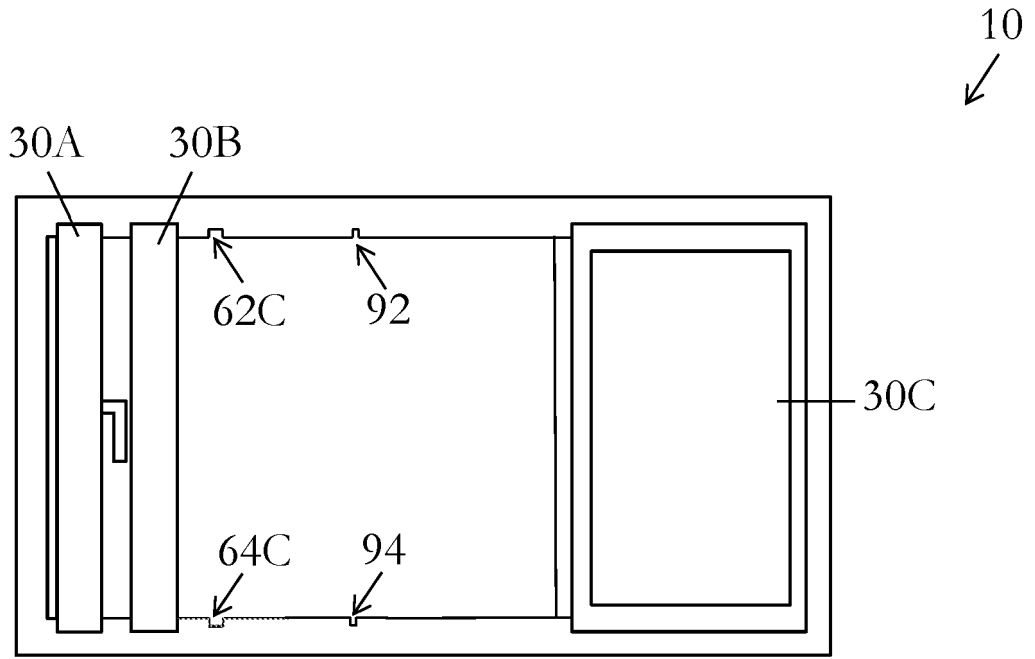

Figure 5

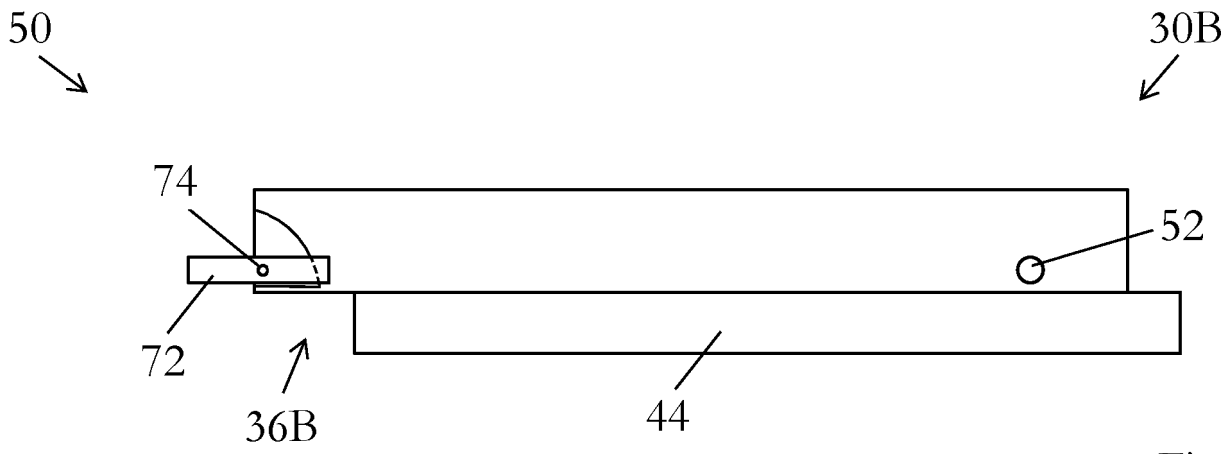

Figure 6

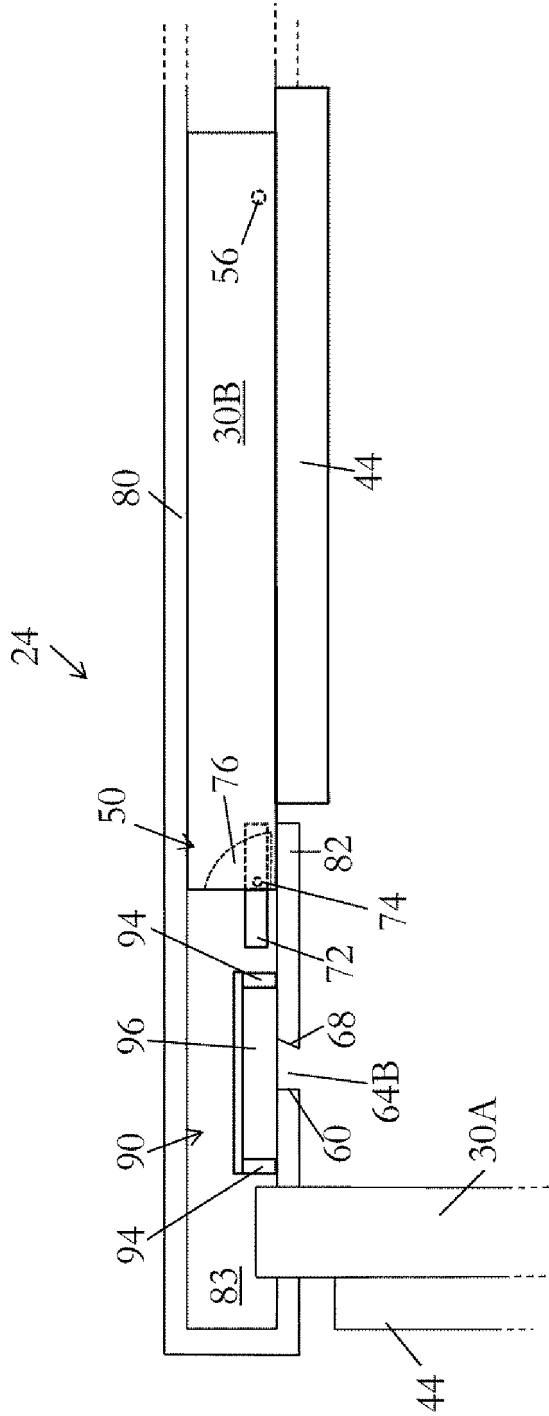

Figure 7

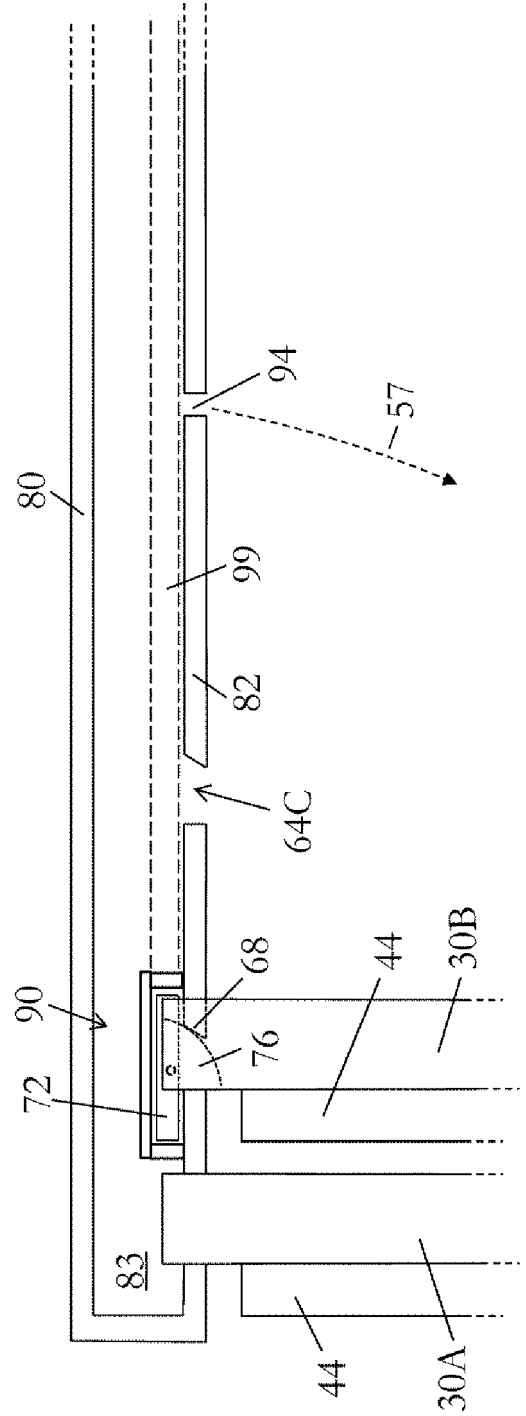

Figure 8

A window

The present invention relates generally to a window and finds particular, although not exclusive, utility in uPVC windows.

5 Traditional windows are openable in several ways such as being moved vertically upwards or downwards, as in the case of sash windows, and being hingedly openable such that one side of the window remains substantially stationary relative to the window frame, as in casement windows.

10 Other types of windows are known such as so-called “tilt and turn” windows, and “curtain” windows, the latter being slidable relative to the frame. With regard to these latter windows it is known to be able to rotate each panel relative to the frame and slide them along a track such that they “stack” up at one end thus creating a relatively large opening. Such a system is known from US2011/0088326A1.

15 However, this known system is directed at windows having aluminium frames and being of relatively large size. Accordingly, the system is relatively heavy and requires relatively substantial structures to support it. Moreover, the system is typically not used in situations where the windows form the primary building envelope closure. In other words, they are used to keep wind from a terrace with the building having a separate set of windows acting as the primary seal against the elements.

20 It is desirable to have a system which allows typical domestic windows, which do form the primary weather seal, to be moved relative to the frame such that substantially the whole of the frame is opened in one unbroken space.

25 In one aspect, the invention provides a window comprising a frame including a head, a sill, and two side jambs, the window further comprising at least first and second casements, wherein the first casement includes hinges for rotating it relative to the frame, the hinges being movable relative to the frame along channels provided in the sill and head such that the first casement is slidable within the frame, the first casement also including at least one guide located on the upper and/or lower surface of the first casement distal from the hinges and movable within the respective head or sill channel
30 as the first casement slides relative to the frame, the said at least one guide disengagable from the respective head or sill channel allowing the at least one guide to pass out of the respective channel thus allowing the first casement to be opened relative to the frame.

In this way, typical window systems are openable and slidable relative to the frame such that substantially the whole of the frame is opened in one unbroken space.

The windows may be single, double or triple glazed. They may comprise uPVC frames and casement members although other materials are contemplated such as
5 aluminium and wood.

The guide is trapped within the respective channel such that it can substantially only move reciprocally along the frame in a direction parallel to the glass panes in the casement with it in its closed (un-pivoted) positions.

The first casement may include a guide on its upper and lower surfaces. The
10 frame may include a sill channel and a head channel. The channels may be defined by a rear surface of the frame on one side and by a lip at the front of the frame on the other side. The lip may be retro-fittable to an existing frame. However, the channel(s) may be initially separate and retro-fitted to an existing frame.

The respective head or sill channel may include a guide slot for allowing the said
15 at least one guide to be disengaged therefrom. The term 'disengage' may be understood to mean that the guide may be released from the channel.

The guide slot may be located in the lip forming one sidewall of the channel.

Alternatively, or additionally, the first casement may include guide control means for retracting and extending the said at least one guide relative to the first casement. In
20 this way the guide(s) may be retracted relative to the casement to allow the casement to hingedly open relative to the frame. The control means may be biased to the extended position and retracted by temporarily overcoming the biasing means. For instance, the guide(s) may be biased by a spring and the control means may mechanically pull the guide(s) against the spring to retract it.

The frame may include a sliding surface comprising relatively low friction
25 material to ease the sliding of the first casement relative thereto. The material may be TEFLON (RTM) although other such low friction materials are contemplated. The sliding surface may extend along the base of the channel(s).

The first casement may include a sliding surface comprising relatively low
30 friction material to ease its sliding relative to the frame. The material may be TEFLON (RTM) although other such low friction materials are contemplated. The sliding surface may extend along the upper and lower surfaces of the casement sides.

At least one hinge may comprise a first part having an approximate quadrant shape and a second part having a rectilinear portion, wherein the parts are pivoted to one another and the first part is attached to the upper or lower surface of the hinge side of the first casement and the second part is slidable along the respective channel. It is contemplated that the first casement may comprise such a hinge on both its upper and lower surfaces. The hinges may be located towards one end of each of the upper and lower surfaces.

In this way, the casement is rotatable relative to the frame with the second part(s) remaining within the channel(s) and the first part(s) rotating with the casement.

The frame may include a landing strip at the point where the hinge of the first casement is positioned for rotatable opening. The landing strip may comprise a side wall to reduce the width of the respective channel such that it is approximately equal to the width of the second part. This may provide additional resilience and stability in the system when the casement is rotatably opened.

The landing strip may be located on the sill and may include a surface with bevelled ends to ease the passage of the second part onto the surface such that the first casement is lifted relative to the frame. The casement may be lifted in the range of 1 to 5mm. The lifting may help to prevent an upper hinge from leaving the head channel. This may occur due to substantially all of the weight of the casement being borne by the hinge on the lower surface of the casement, and the casement tilting outwardly at the top.

The surface may comprise metal. The landing strip may be entirely made from metals and may comprise aluminium.

The frame may include at least one hinge slot in each of the head and sill channels for allowing the first part of the hinges to pass at least partially out of the respective channel as the casement is rotatably opened. The hinge slots may be located in the sidewalls of the channels and may be in the lip forming one sidewall of the channels.

The hinge slots may include a sidewall lying at an angle of approximately 45 degrees relative to a plane parallel with the surface of the glass panes in the closed (unrotated) position. In this way, a side of the quadrant may be supported by the said sidewall as the first casement is rotatably opened.

It is contemplated that a reinforcing gate member may be inserted into at least one of the hinge slots, preferably the sill hinge slot. In this case it is the sidewall of the reinforcing gate member which may lie at an angle of approximately 45 degrees relative to a plane parallel with the surface of the glass panes in the closed position. Also, it is the sidewall of the gate which may support a side of the quadrant as the first casement is rotatably opened.

Furthermore, the reinforcing gate member and the landing strip may be unitary. This may simplify manufacture and installation and provide a more rigid support structure.

The first and second casements may completely fill the frame in their closed positions such that the first casement is only slidably movable relative to the frame after the second casement has been rotatably opened, the second casement comprising hinges which allow it to be opened relative to the frame, and the at least one guide slot being located in the respective head or sill channel such that the first casement is only openable after it has been slidably moved relative to the frame.

In this way, the first casement may only move reciprocally within the frame until such time as the guide has left the confines of the channel.

The position of the hinge slot(s) and/or guide slot(s) may be selectively positioned relative to the channels so as to only allow the rotation (opening) of the first casement relative to the frame with the first casement in certain positions relative to the frame. Several guide slots and/or hinge slots may be provided to allow the first casement to be rotated relative to the frame at more than one position relative to the frame.

The window may be arranged such that the first and second casements are openable by approximately 90 degrees relative to the frame, and the first casement being positionable in this open position immediately adjacent the second casement so as to provide a relatively wide opening in the frame.

The window may comprise more than two casements wherein each casement is openable by approximately 90 degrees relative to the frame, and the casements being positionable in this open position immediately adjacent one another so as to provide a relatively wide opening in the frame.

In either situation, the casements may be “stacked”, in a side-by-side manner, at one end of the frame.

The above and other characteristics, features and advantages of the present invention will become apparent from the following detailed description, taken in conjunction with the accompanying drawings, which illustrate, by way of example, the principles of the invention. This description is given for the sake of example only, without limiting the scope of the invention. The reference figures quoted below refer to the attached drawings.

Figure 1 is a schematic elevation of a window with the casements closed;

Figure 2 is a schematic plan of the window of Figure 1 with the casements in the open and stacked position;

Figure 3 is a schematic elevation of one casement of the window of Figure 1;

Figure 4 is a schematic elevation of the window of Figure 1 with one casement in the stacked open position;

Figure 5 is a schematic elevation of the window of Figure 1 with two casements in the stacked open position;

Figure 6 is a schematic plan of the casement of Figure 3;

Figure 7 is a schematic plan one casement in position on the sill; and

Figure 8 is a schematic plan of the casement of Figure 7 in the stacked position on the sill.

The present invention will be described with respect to certain drawings but the invention is not limited thereto but only by the claims. The drawings described are only schematic and are non-limiting. Each drawing may not include all of the features of the invention and therefore should not necessarily be considered to be an embodiment of the invention. In the drawings, the size of some of the elements may be exaggerated and not drawn to scale for illustrative purposes. The dimensions and the relative dimensions do not correspond to actual reductions to practice of the invention.

Furthermore, the terms first, second, third and the like in the description and in the claims, are used for distinguishing between similar elements and not necessarily for describing a sequence, either temporally, spatially, in ranking or in any other manner. It is to be understood that the terms so used are interchangeable under appropriate circumstances and that operation is capable in other sequences than described or illustrated herein.

Moreover, the terms top, bottom, over, under and the like in the description and the claims are used for descriptive purposes and not necessarily for describing relative

positions. It is to be understood that the terms so used are interchangeable under appropriate circumstances and that operation is capable in other orientations than described or illustrated herein.

5 It is to be noticed that the term “comprising”, used in the claims, should not be interpreted as being restricted to the means listed thereafter; it does not exclude other elements or steps. It is thus to be interpreted as specifying the presence of the stated features, integers, steps or components as referred to, but does not preclude the presence or addition of one or more other features, integers, steps or components, or groups thereof. Thus, the scope of the expression “a device comprising means A and 10 B” should not be limited to devices consisting only of components A and B. It means that with respect to the present invention, the only relevant components of the device are A and B.

Reference throughout this specification to “an embodiment” or “an aspect” means that a particular feature, structure or characteristic described in connection with 15 the embodiment or aspect is included in at least one embodiment or aspect of the present invention. Thus, appearances of the phrases “in one embodiment”, “in an embodiment”, or “in an aspect” in various places throughout this specification are not necessarily all referring to the same embodiment or aspect, but may refer to different embodiments or aspects. Furthermore, the particular features, structures or 20 characteristics of any embodiment or aspect of the invention may be combined in any suitable manner, as would be apparent to one of ordinary skill in the art from this disclosure, in one or more embodiments or aspects.

Similarly, it should be appreciated that in the description various features of the invention are sometimes grouped together in a single embodiment, figure, or description 25 thereof for the purpose of streamlining the disclosure and aiding in the understanding of one or more of the various inventive aspects. This method of disclosure, however, is not to be interpreted as reflecting an intention that the claimed invention requires more features than are expressly recited in each claim. Moreover, the description of any individual drawing or aspect should not necessarily be considered to be an embodiment 30 of the invention. Rather, as the following claims reflect, inventive aspects lie in fewer than all features of a single foregoing disclosed embodiment. Thus, the claims following the detailed description are hereby expressly incorporated into this detailed description, with each claim standing on its own as a separate embodiment of this invention.

Furthermore, while some embodiments described herein include some features included in other embodiments, combinations of features of different embodiments are meant to be within the scope of the invention, and form yet further embodiments, as will be understood by those skilled in the art. For example, in the following claims, any
5 of the claimed embodiments can be used in any combination.

In the description provided herein, numerous specific details are set forth. However, it is understood that embodiments of the invention may be practised without these specific details. In other instances, well-known methods, structures and techniques have not been shown in detail in order not to obscure an understanding of
10 this description.

In the discussion of the invention, unless stated to the contrary, the disclosure of alternative values for the upper or lower limit of the permitted range of a parameter, coupled with an indication that one of said values is more highly preferred than the other, is to be construed as an implied statement that each intermediate value of said
15 parameter, lying between the more preferred and the less preferred of said alternatives, is itself preferred to said less preferred value and also to each value lying between said less preferred value and said intermediate value.

The use of the term “at least one” may mean only one in certain circumstances.

The principles of the invention will now be described by a detailed description
20 of at least one drawing relating to exemplary features of the invention. It is clear that other arrangements can be configured according to the knowledge of persons skilled in the art without departing from the underlying concept or technical teaching of the invention, the invention being limited only by the terms of the appended claims.

In Figure 1, the window 10 comprises a frame 20 including a head 22 at the top,
25 a sill 24 at the bottom, a right hand side 26 and a left hand side 28. Three casements 30A, 30B, 30C are arranged across, and partially within, the frame to form a weatherproof seal. Each casement includes a pane of glass 40. The centre casement 30B and the right hand casement 30C both include mullion portions 36B, 36C on their left hand sides to provide a weatherproof seal between, and to space them apart. Figure
30 1 shows the view looking from outside towards the inside of a building in which the window would typically be installed.

In use the left hand casement 30A may be opened in a traditional manner hinged along its left hand side and pivotably opened outwards. The centre casement

30B may then slide along the frame towards the left before being pivoted outwards to lie approximately parallel to the previously opened left hand casement 30A. Finally, the right hand casement 30C may then slide along the frame towards the left before being pivoted outwards to lie approximately parallel to the previously opened left and centre hand casements 30A, 30B.

A schematic plan view of the window after the three casements have been opened in this manner is shown in Figure 2. A handle 35 is shown on the left hand casement 30A as this is typically how that casement will be opened and closed and locked and unlocked. In Figure 2 the head 22 is visible and each casement 30A, 30B, 30C extends substantially perpendicularly away from the longitudinal length of the head 22; although it is to be understood that the casements could be positioned such that the angle between them and the length of the head 22 is less than 90 degrees. The casements are only shown indicatively and do not include all of the various features such as the mullions 36B, 36C.

An elevational view of the centre casement 30B is shown in Figure 3. The view is looking from the outside to the inside (in other words the casement hinges open, in use, towards the viewer). The casement comprises a rectangular frame 31 within which the pane of glass (or double or triple glazed unit) is held. The frame is a typical casement frame comprising any of uPVC, metals, wood and other such materials.

Along the left hand side (“hinge side”) a mullion 36B is provided. This is stepped back from the front face of the casement and provides the spacing between adjacent casements.

An upper hinge 50 is provided on the upper surface of the top of the frame 31 towards the upper left hand corner for allowing the casement to pivot relative to the window frame 20. Likewise, a lower hinge 54 is provided towards the lower left hand corner on the lower surface of the bottom of the frame 20.

A guide 52 is also arranged on the upper surface of the top of the frame towards the upper right hand end corner. Similarly, a guide 56 is arranged on the lower surface of the bottom of the frame towards the lower right hand corner. It is contemplated that in one embodiment only one guide 52, 56 is provided on one of the two outer surfaces of the frame 31. Equally, more than one guide may be provided on one or more outer surfaces of the frame 31.

In Figure 4, the elevational view shows the left hand casement 30A having been fully opened such that the plane of the glass 40 is lying substantially perpendicular to the plane of the glass in the other two unopened casements 30B, 30C.

The handle 35 is visible on the left hand casement 30A.

5 A gap 60 is visible between the outer face of the opened casement 30A and the left hand side 28 of the window frame 20.

The centre casement 30B has been slid along the window frame 20 towards the left. This is possible due to the hinges 50, 54 being arranged to slide in channels provided in the sill 24 and head 22 of the window frame as will be explained in more
10 detail below.

The mullion 36B which lies between the left hand and centre casements 30A, 30B with the windows all in the closed position is also visible along the left hand side of the casement 30B.

The right hand casement 30C has not yet been moved and is shown in its fully
15 closed position immediately adjacent the right hand side 26 of the window frame 20.

Openings 62B, 64B in the front faces of the channels arranged in the sill 24 and head 22 are visible immediately to the right of the opened left hand casement 30A. These allow the centre casement 30B to pivot relative to the window frame 20 as will be explained in more detail below.

20 The window 10 with the left hand and centre casements 30A, 30B in their fully open and “stacked” position at the left hand end of the window frame 20 is shown in Figure 5. In this regard, from the position shown in Figure 4, the centre casement 30B will have been moved further to the left parallel with the window frame 20 such that its top and bottom hinges 50, 54 will have reached the openings 62B, 64B in the channels.
25 Also, the guides 52, 56 will have reached additional openings (guide slots) 92, 94 provided in the channels in the sill 24 and head 22 such that they can exit the channels. In this way, the centre casement may be pivoted relative to the window frame 20 such that it lies as shown in Figure 5 being approximately parallel to the already opened left hand casement 30A.

30 The hinge 50 arranged on the upper surface of the top of the centre casement 30B is shown in plan in Figure 6. The hinge 50 comprises a quadrant planar member 76 fixed to the upper surface of the casement. It is oriented such that the centre of radius is located towards the outer left hand corner of the casement 30B with the arc lying

towards the right and rear of the casement relative to this centre of radius. It may be comprise substantially low friction material to aid the operation of the hinge and to ease the sliding of the casement along the sill 24 and head 22 of the window frame 10.

5 Affixed to the upper surface of this quadrant is a rectilinear member 72 which is relatively long in a direction parallel to the top of the casement 30B, and having a relatively narrow body in a direction parallel to the thickness of the casement 30B. It is relatively thin in a direction parallel to the height of the casement when installed in a window frame. The rectilinear member 72 is pivotally connected 74 to the quadrant at a point near to the outer left hand corner of the casement and substantially adjacent to, or
10 coincident with, the centre of radius of the quadrant 76.

The rectilinear member 72 is comprised of relatively low friction material to ease the sliding of the casement along the window frame 20.

The mullion portion 36B of the casement 30B is visible on the left of the portion 44 which retains the glass 40. The hinge 50 is shown attached to the mullion
15 portion 36B.

The hinge 54 arranged on the lower surface of the casement 30B comprises an identical arrangement of components.

Also visible on the upper surface of the casement 30B is the guide member 52. It is located towards the right hand end of the upper surface of the casement. An
20 identical one 56 may also be provided on the lower surface of the casement 30B.

Figure 7 provides an indicative plan view of a portion of the window 10. A portion of the sill 24 is visible comprising a rear lip 80 and a front lip 82. These two lips define a channel 83 extending substantially across the width of the sill 24. A similar channel (not shown) is provided in the head 22. Within these two channels the
25 casements 30B, 30C may slide as will be explained below.

In Figure 7, the left hand casement 30A has already been opened and a portion of it is visible lying approximately perpendicular to the longitudinal length of the sill 24. The outline of the centre casement 30B is indicated to the right of the left hand casement 30A. The lower hinge 54 is shown. The rectilinear member 72 is shown
30 extending out from underneath the casement 30B such that approximately half its length is underneath and half exposed.

A landing stage 90 is arranged within the sill 24. It comprises a surface 96 parallel with, and slightly raised relative to, the base of the channel 83. At each end of

the surface 96 are provided ramps 94. At the rear of the surface 96 a wall 92 is provided.

In use, as the casement 30B is moved along the channel 83 the rectilinear member 72 of the hinge 54 will slide up the right hand ramp 94 and then travel along the surface 96. It is expected that the centre casement 30B will then come to rest at this point with the rectilinear member 72 on top of the surface 96 of the landing stage 90.

The landing stage raises the casement relative to the sill 24. This may be desirable to prevent “sagging” of the casement when rotatably opened. The landing stage 90 also provides additional strength to the sill 24 which may only comprise uPVC materials.

In Figure 8 the casement 30B is shown as having been pivotably opened relative to the window frame 20. As it opens the rectilinear member 72 remains substantially stationary within the reduced width channel formed by the rear wall 92 of the landing stage 90 and the front lip 82 of the sill 24.

However, the quadrant 76 has rotated with the casement 30B relative to the window frame 20 and at least partially extended through an opening 64B provided within the front lip 82 forming the channel 83.

The left hand side 66 of the opening 64B lies perpendicularly to the longitudinal length of the sill 24. The right hand side 68 of the opening, however, lies at approximately 45 degrees to the longitudinal length of the sill 24. It is seen how this right hand side at least partially presses against the perimeter of the quadrant 76 with the casement in the open position. This provides some support to the hinge 54. It is possible that the right hand side 68 of the opening is curved to more closely match the arc of the perimeter of the quadrant member 76.

The upper hinge 50 also operates in the same manner as the lower hinge 54 with respect to the head 22 of the frame 20.

With the centre casement 30B in the open “stacked” position shown in Figure 8 an opening 94 in the side of the channel 83 is visible. Previously it was hidden by the casement 30B in the closed (pre-pivoting) position. This opening 94 allows the guide member 56 to exit the channel 83, as the casement is pivoted open relative to the window frame 10, in an arc as indicated by reference “57” in Figure 8.

The same opening 94 can also be used with the right hand casement 30C. However, the position of the guide member on the lower surface of the casement 30C,

relative to the bottom hinge on the same casement 30C will be different to that of the centre casement 30B to accommodate the different distance between the hinge slot 64B and guide slot 94, and the hinge slot 64C and guide slot 94. This will be the same for the position of the guide member on the upper surface of the centre casement 30C. In this way, the same guide slots 92, 94 can be used with both the centre and right hand casements.

In a similar manner, if more than three casements are provided the subsequent casements may also use the same guide slots 92, 94 as long as the respective guide members are positioned relative to their hinges to match the distance between the relevant hinge slots and the guide slots 92, 94.

However, it is preferable not to position the guide members at positions less than half the width of the casement from the hinges as this may reduce security and the ease with which the casements slide. If the number of casements is above a number whereby the distance of the guide members would have to be less than half the width of the casement then additional guide slots (not shown) may be provided in the head or sill channels.

The hinge opening 64C in the front lip 82 of the sill 24 is visible in Figure 8. Previously it was also hidden by the casement 30B in the closed (pre-pivoting) position. This opening 64C will allow the right hand casement 30C to pivotably open relative to the frame 20 in a similar manner as the centre casement 30B such that it may also be “stacked” against the other two casements and in this way substantially fully open the window 10. In other words, the right hand casement 30C (not shown) may be slid along the sill 24 until its lower hinge meets the opening 64C. At this point, the casement may be pivoted relative to the window frame 20.

This is effected by the guide member on the casement 30C passing through the same opening 94 in the side of the channel 83 in the sill 24. This opening 94 allows the guide member on the underside of the casement 30C to exit the channel 83 in an arc 57.

In Figure 8 a track 99 is indicated in the base of the channel 83. This track may comprise relatively low friction material to aid the sliding of the rectilinear member 72 therealong. Other arrangements such as ball-bearings and wheels are contemplated to be provided between the base of the casements and the base of the channel.

The arrangement of openings 64B, 64C, 94 in the channels 83 may be arranged such that each casement has its own set of openings to allow the hinges and guide members to exit the channels.

5 To close the windows the reverse procedure is performed. In other words, the casements are pivoted back towards the window frame 20 such that the guide members and hinges may re-enter the channels. The casements may then be slid along the sill 24 to the required position. Finally, the left hand casement 30A may be pivoted back towards the closed position and then locked shut with a locking handle in a similar manner to conventional uPVC double glazed windows. With the left hand casement 10 30A in the locked and closed position none of the other casements may be opened.

In one embodiment, there may be more than the three casements described with reference to these Figures. They may be slid and pivoted relative to the window frame in the same manner as described above such that more than three casements are stacked up at one end.

15 It will be understood that the arrangement of the left hand casement may be applied to a right hand casement as well as, or instead of, the left hand casement described above. In other words, the casements may be arranged to stack at the right hand end of the window frame 20.

20 Alternatively or additionally, the window 10 may be arranged such that the casements stack in a position intermediate between the right and left hand ends.

Alternatively or additionally, the window 10 may be arranged such that the both the right and left hand casements are only openable in a pivoting manner and not slidable, relative to the window frame 20, with the intermediate casements being arranged to be stacked at either or both ends of the frame 20.

25 Alternatively or additionally, the window 10 may be arranged such that the casements pivot inwards relative to the building in which the frame 20 is installed. In this regard, the openings 64B, 64C, 92, 94 would be located on the wall of the channel closest to the inside of the building (i.e. the rear of the channel).

30 In the Figures, some features which are obscured by other features are shown in dashed lines to provide greater clarity. For instance, the quadrant 76 in Figure 7 is shown with a dashed line as it would not be visible in this plan view as it is underneath the casement.

CLAIMS

1. A window comprising a frame including a head, a sill, and two side jambs, the window further comprising at least first and second casements, wherein the first casement includes hinges for rotating it relative to the frame, the hinges being movable relative to the frame along channels provided in the sill and head such that the first casement is slidable within the frame, the first casement also including at least one guide located on the upper and/or lower surface of the first casement distal from the hinges and movable within the respective head or sill channel as the first casement slides relative to the frame, the said at least one guide disengagable from the respective head or sill channel allowing the at least one guide to pass out of the respective channel thus allowing the first casement to be opened relative to the frame.
2. The window according to claim 1, wherein the respective head or sill channel includes a guide slot for allowing the said at least one guide to be disengaged therefrom.
3. The window according to claim 1, wherein the first casement includes guide control means for retracting and extending the said at least one guide relative to the first casement.
4. The window according to any preceding claim, wherein the frame includes a sliding surface comprising relatively low friction material to ease the sliding of the first casement relative thereto.
5. The window according to any preceding claim, wherein the first casement includes a sliding surface comprising relatively low friction material to ease its sliding relative to the frame.
6. The window according to any preceding claim, wherein at least one hinge comprises a first part having an approximate quadrant shape and a second part having a rectilinear portion, wherein the parts are pivoted to one another and the first part is attached to the upper or lower surface of the

hinge side of the first casement and the second part is slidable along the respective channel.

- 5 7. The window according to claim 6, wherein the frame includes a landing strip at the point where the hinge of the first casement is positioned for rotatable opening, the landing strip comprising a side wall to reduce the width of the respective channel such that it is approximately equal to the width of the second part.
- 10 8. The window according to either one of claims 6 and 7, wherein the landing strip is located on the sill and includes a surface with bevelled ends to ease the passage of the second part onto the surface such that the first casement is lifted relative to the frame.
- 15 9. The window according to claim 8, wherein the surface comprises metal.
- 20 10. The window according to any one of claims 6 to 9, wherein the frame includes at least one hinge slot in each of the head and sill channels for allowing the first part of the hinge to pass at least partially out of the respective channel as the casement is opened.
- 25 11. The window according to claim 10, wherein the said at least one hinge slot includes a sidewall lying at an angle of approximately 45 degrees relative to a plane parallel with the surface of the glass windows in the closed position.
- 30 12. The window according to claim to 11, wherein a side of the quadrant is supported by the said sidewall as the first casement is opened.
- 35 13. The window according to any one of claims 10 to 12, wherein a reinforcing gate member is inserted into the hinge slot.
14. The window according to claim 13, when dependent on either one of claims 11 and 12, wherein the sidewall of the hinge slot is replaced by the sidewall of the reinforcing gate member.

15. The window according to either one of claims 13 and 14, when on any one of claims 7 to 9, wherein the reinforcing gate member and the landing strip are unitary.
- 5 16. The window according to any preceding claim, wherein the first and second casements completely fill the frame in their closed positions such that the first casement is only slidably movable relative to the frame after the second casement has been opened, the second casement comprising hinges which allow it to be opened relative to the frame, and the at least one guide slot is
10 located in the respective head or sill channel such that the first casement is only openable after it has been slidably moved relative to the frame.
17. The window according to claim 16, being arranged such that the first and second casements are openable by approximately 90 degrees relative to the
15 frame, and the first casement is positionable in this open position immediately adjacent the second casement so as to provide a relatively wide opening in the frame.
18. The window according to any one of claims 1 to 15, comprising more than
20 two casements wherein each casement is openable by approximately 90 degrees relative to the frame, and the casements are positionable in this open position immediately adjacent one another so as to provide a relatively wide opening in the frame.
- 25 19. A window substantially as hereinbefore described with reference to the accompanying drawings.



Application No: GB1422581.7

Examiner: Ben Munns

Claims searched: 1-19

Date of search: 26 May 2015

Patents Act 1977: Search Report under Section 17

Documents considered to be relevant:

Category	Relevant to claims	Identity of document and passage or figure of particular relevance
X	1, 2, 4, 5, 16-18	US 2011/0088326 A1 (INGRAM) see the entire document, particularly paragraph 63.
X	1, 2, 4, 5, 16-18	US 2005/0229512 A1 (SARNELL et al) see particularly the figures, guide 5, 33, hinge 7.
X	1, 2, 4, 5, 16-18	EP 1496182 A2 (FRUBAU) see particularly the figures and WPI Abstract Accession No.: 2005-082855.
X	1, 2, 4, 5, 16-18	EP 1892362 A1 (LUMON) see particularly the figure and WPI Abstract Accession No.: 2008-D18763.
X	1, 2, 4, 5, 16-18	US 5749172 A (ISOPAHKALA) see particularly the figures, hinge 26 being sliding block 45, pivoted cam 48, guide element 25.
X	1, 2, 4, 5, 16-18	WO 2011/135131 A1 (C3 SYSTEMS) see particular the figures and abstract.
X	1, 2, 4, 5, 16-18	US 2014/0326419 A1 (ONA-GONZALEZ) see the entire document.
X	1, 3-5, 16-18	US 3654732 A (SCHACHT) see the entire document.

Categories:

X	Document indicating lack of novelty or inventive step	A	Document indicating technological background and/or state of the art.
Y	Document indicating lack of inventive step if combined with one or more other documents of same category.	P	Document published on or after the declared priority date but before the filing date of this invention.
&	Member of the same patent family	E	Patent document published on or after, but with priority date earlier than, the filing date of this application.

Field of Search:

Search of GB, EP, WO & US patent documents classified in the following areas of the UKC^X:

--



Worldwide search of patent documents classified in the following areas of the IPC

E05D

The following online and other databases have been used in the preparation of this search report

EPODOC, TXTA, WPI

International Classification:

Subclass	Subgroup	Valid From
E05D	0015/48	01/01/2006
E05D	0015/06	01/01/2006
E05D	0015/58	01/01/2006
E06B	0003/46	01/01/2006