

J. CROSWELL.
SINK, BOWL, &c.
APPLICATION FILED SEPT. 26, 1903.

NO MODEL.

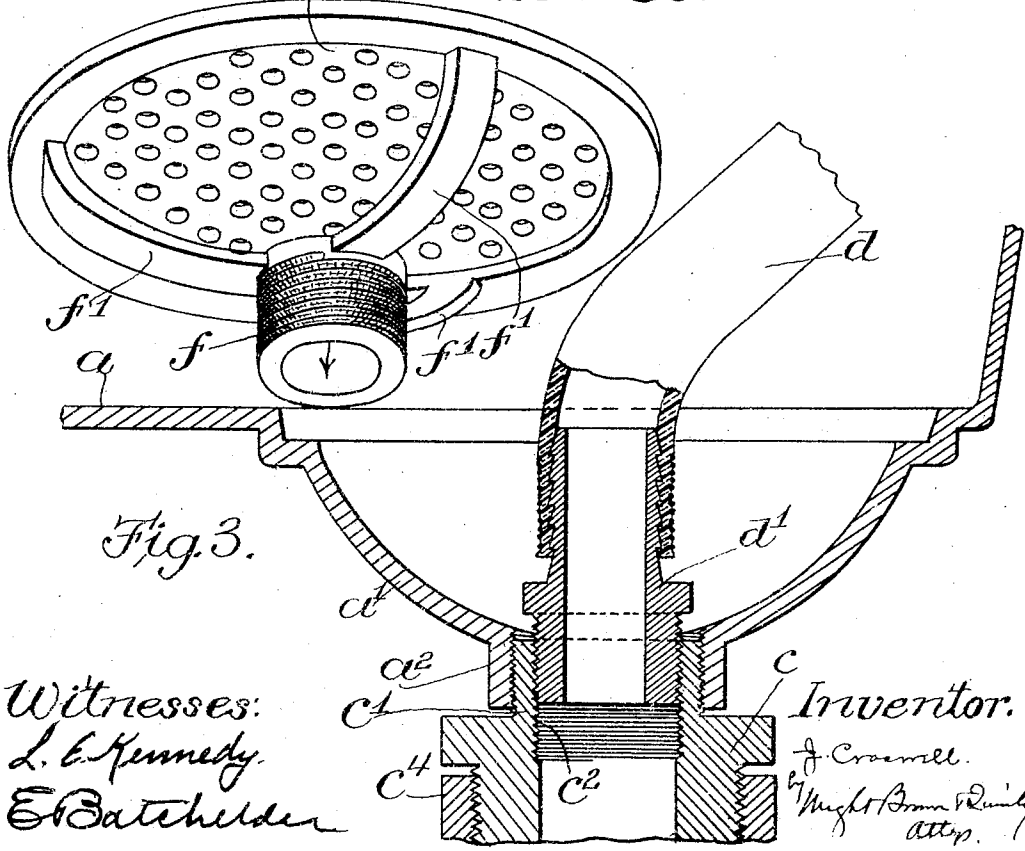
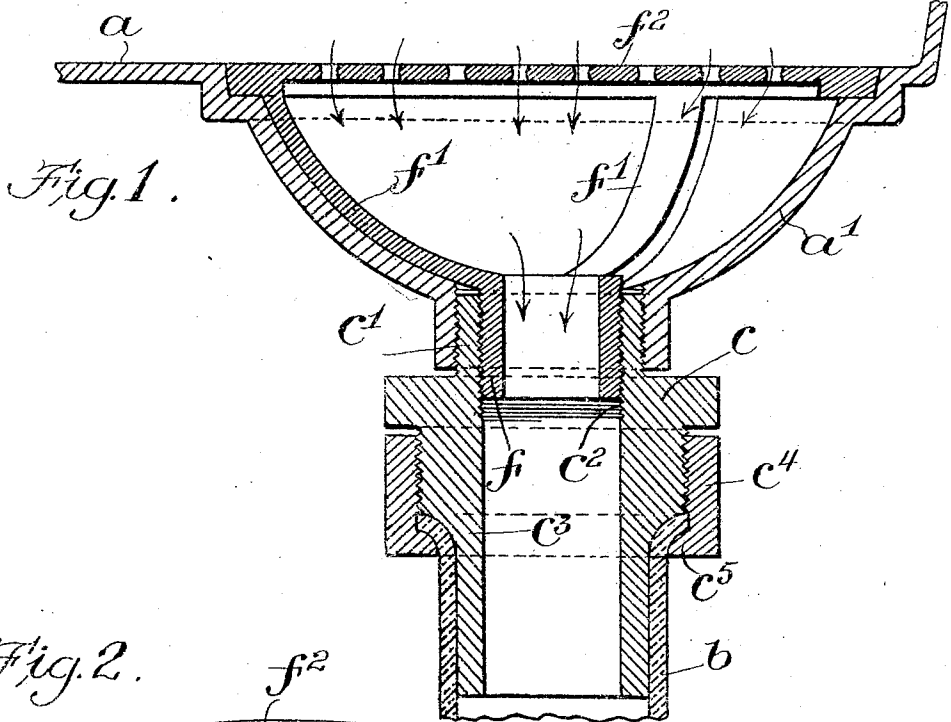

Witnesses:
L. E. Kennedy
E. Batchelder

Inventor:
J. Crowell.
Wright Brown & Quincy
attys.

UNITED STATES PATENT OFFICE.

JOHN CROSWELL, OF WELLESLEY, MASSACHUSETTS.

SINK, BOWL, &c.

SPECIFICATION forming part of Letters Patent No. 765,131, dated July 12, 1904.

Application filed September 26, 1903. Serial No. 174,703. (No model.)

To all whom it may concern:

Be it known that I, JOHN CROSWELL, of Wellesley, in the county of Norfolk and State of Massachusetts, have invented certain new and useful Improvements in Sinks, Bowls, &c., of which the following is a specification.

This invention relates to fixed receptacles for water—such as sinks, bowls, &c.—such receptacles being provided with waste-outlets and with waste-pipes coupled to said outlets.

The invention has for its object to provide an improved means for connecting the waste-pipe with the outlet-opening of a sink or bowl, said means also having provisions for connecting with the sink or bowl an attachment, such as a strainer, to prevent the entrance of solid matter into the waste-pipe or the screw-threaded terminal of a hose-pipe adapted to be used for the purpose of forcing obstructions from the waste-pipe or the trap connected therewith.

The invention consists in the improvements which I will now proceed to describe and claim.

Of the accompanying drawings, Figure 1 represents a sectional view of a portion of the bottom of a sink embodying my invention. Fig. 2 represents a perspective view of the strainer shown in Fig. 1. Fig. 3 represents a view similar to Fig. 1, the strainer being omitted and a hose-pipe terminal being inserted in place thereof.

The same reference characters indicate the same parts in all the figures.

In the drawings, *a* represents the bottom of a sink, and *a'* represents a depression or pocket in said bottom, the said depression having an outlet-opening in its central portion surrounded by a boss *a''*. The said outlet-opening is internally screw-threaded, as clearly indicated in Figs. 1 and 3.

c represents a coupling adapted to connect a waste-pipe *b*, of lead or other suitable material, with the sink. The said coupling is provided at its upper portion with an external screw-thread *c'* and with an internal screw-thread *c''*. The external thread *c'* is adapted to engage the internal thread of the boss *a''* to engage the coupling with the sink, while the internal thread *c''* surrounds the waste or

outlet opening. The lower portion of the coupling *c* is provided with means for detachably engaging the waste-pipe *b*, said means, as here shown, comprising a shoulder *c'''*, formed on the body portion of the coupling, and a flanged coupling-nut *c''''*, engaged with a threaded portion of the coupling and having a flange *c'''''*, which engages the bell-shaped or flanged upper end of the waste-pipe, as shown in Figs. 1 and 3. The internal thread *c''* of the coupling, which, as above stated, surrounds the outlet-opening, is adapted to engage an attachment or a plurality of attachments cooperating with the outlet-passage or waste-pipe of the sink. In Fig. 1 I show the internal thread *c''* engaged with an attachment which constitutes a strainer and comprises a circular perforated plate *f''*, adapted to cover the mouth of the pocket *a'*, an externally-threaded tubular shank *f*, formed to engage the internal thread *c''* and having an outlet-passage extending through it, and arms *f'*, connecting the shank *f* with the plate *f''*. It will be seen that the internal thread *c''* of the coupling and the externally-threaded tubular shank of the strainer enable the strainer to be quickly and conveniently applied to and removed from the sink, either of said operations being performed by simply rotating the plate *f''*, an operation which may be conveniently performed by inserting a staple or other appliance in two of the holes of the strainer and imparting a rotary movement through said appliance. In Fig. 3 I show the internal thread *c''*, engaged with a screw-threaded terminal *d'*, affixed to a flexible hose-pipe *d*, the strainer being removed. The hose-pipe *d* may be connected with a source of supply of water under pressure and when connected with the coupling, as shown in Fig. 3, enables the force of the liquid to be utilized in flushing out the waste-pipe and the trap connected therewith.

It is obvious that the described movement, particularly so far as the hose-pipe connection is concerned, may be applied to set bowls as well as to sinks. Said improvement may also be applied to the waste-pipes of refrigerators.

I claim—

1. A sink having a pocket in its bottom and

an internally-threaded opening in said pocket combined with a coupling member externally and internally threaded at its upper portion, the external thread of the coupling being
5 formed to engage the internal thread of said opening, while the internal thread of the coupling surrounds the outlet of said pocket, and a strainer formed to cover the mouth of said
10 pocket and provided with a tubular, externally-threaded shank formed to engage the internal thread of the coupling, the said coupling having means at its lower end for engagement with a waste-pipe.

2. A sink having a pocket in its bottom and
15 an internally-threaded opening in said pocket, combined with a coupling member externally and internally threaded at its upper portion, the external thread of the coupling being formed to engage the internal thread of said

opening while the internal thread of the coupling surrounds the outlet of said pocket, and a strainer comprising a plate formed to cover the mouth of said pocket and having arms extending downward from its outer edge and fitting the inner surface of the pocket and
25 provided with a tubular externally-threaded shank at the lower ends of said arms said shank being formed to engage the internal thread of the coupling, the said coupling having means at its lower end for engagement with
30 a waste-pipe.

In testimony whereof I have affixed my signature in presence of two witnesses.

JOHN CROSWELL.

Witnesses:

GOLDMANN EDMUNDS,
MARY L. CLARKE.