

June 30, 1959

H. L. R. SMYTH

2,892,966

AUTOMATIC LAMP CHANGERS

Filed June 10, 1957

2 Sheets-Sheet 1

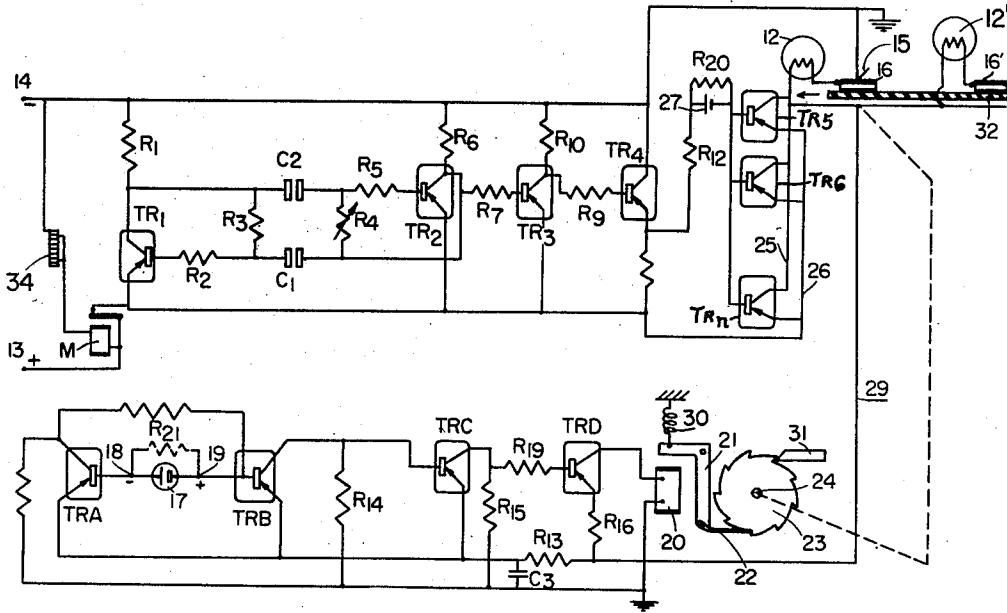

Fig. 1.

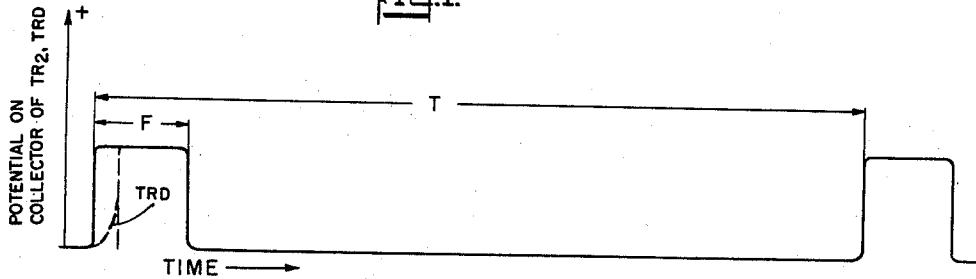

Fig. 3a.

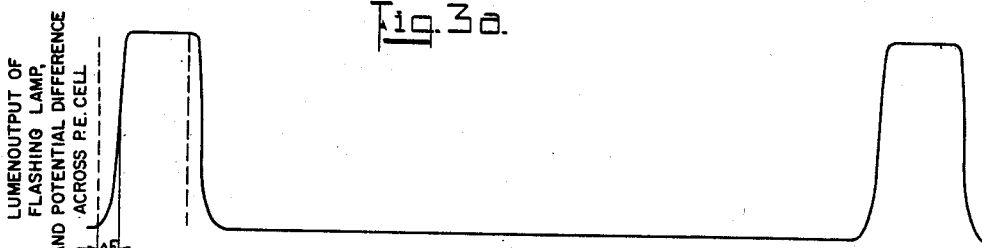

Fig. 3b.

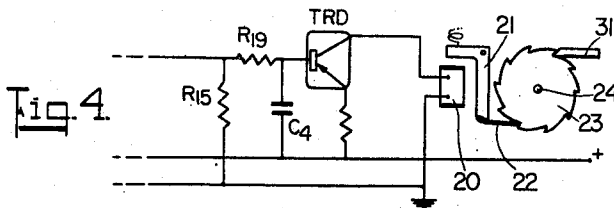

Fig. 4.

INVENTOR  
 HENRY LYALL ROSS  
 SMYTH  
 by R. J. Filipkowski  
 AGENT

June 30, 1959

H. L. R. SMYTH

2,892,966

AUTOMATIC LAMP CHANGERS

Filed June 10, 1957

2 Sheets-Sheet 2

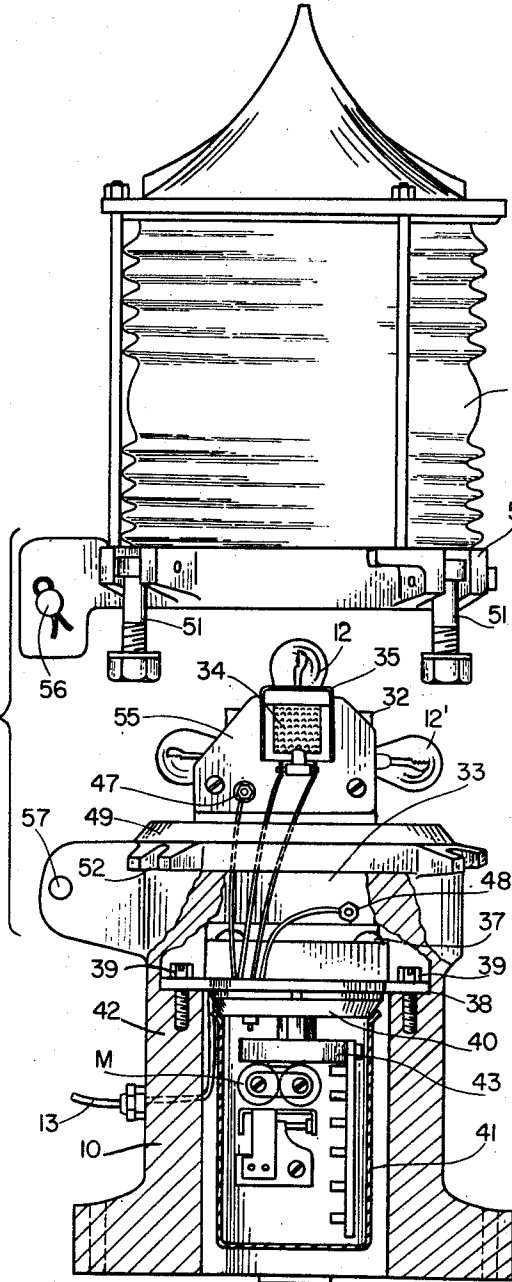

Fig. 2.

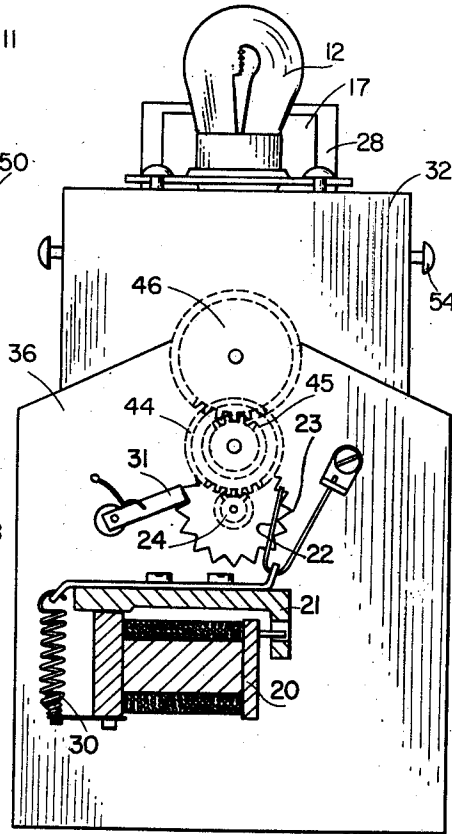

Fig. 5.

INVENTOR  
HENRY LYALL ROSS SMYTH

by R. J. Filipkowski  
AGENT

1

2,892,966

## AUTOMATIC LAMP CHANGERS

Henry Lyall Ross Smyth, Ottawa, Ontario, Canada, assignor to National Research Council, Ottawa, Canada, a body corporate under and by virtue of the Research Council Act, Chapter 239, Revised Statutes of Canada

Application June 10, 1957, Serial No. 664,605

6 Claims. (Cl. 315—89)

This invention relates generally to light-responsive controls associated with lamp flashing apparatus of the type incorporating a monitor to detect failure of a lamp and to control lamp changing mechanism for automatically substituting a replacement in response to a detected failure. More specifically the invention is concerned with providing monitor means responsive to absence of light output when a lamp is defective to cause a lamp-holding turret mechanism to be rotated to bring another lamp into the flashing circuit.

Navigational marker lights installed on buoys, particularly unattended buoy lights situated in remote locations serving inland waterway and coastal marine craft, are required to operate reliably for long periods of time without attention. Such lights desirably are fitted with automatic lamp replacement apparatus to provide continuity of service, and in some installations lamps are deliberately burned under over-voltage conditions to increase efficiency, necessitating frequent replacement. The number of inspections per year or per season which it has heretofore been found necessary to carry out in order to maintain a given standard of performance of the complete installation has incurred a costly upkeep charge. The maintenance problem is particularly aggravated when the marker lights are located in hazardous waters and at very distant sites. The apparatus presently in use is characterized by complexity and bulk, involving motor-actuated switch devices and circuit breakers for interruptedly energizing a stepping motor magnet in response to an open lamp circuit condition. These devices have required frequent attention to the switching contacts.

Heretofore apparatus devised for and employed at unattended navigation marker lights for detecting a lamp failure has depended on change in the resistance of a lamp filament circuit, for example the change from usual operating resistance to substantially infinite resistance of a broken or burnt out filament. A defective lamp disables a detecting relay, whose contacts remain closed, thereby supplying battery to an electromagnetic stepping motor which is self-interrupting by means of a mechanical linkage to the detecting relay, and drives a turret loaded with lamps connected to switching segments until a good lamp is in circuit. The detecting relay and the self interrupting stepping relay have both proved to be sources of trouble, the interruptor contacts in particular being susceptible to sticking or failure, due to maladjustment.

Accordingly this invention is concerned to provide the combination of a periodic switching circuit which does not use moving contacts employing transistor devices for energizing a signal lamp at intervals, with motor-driven lamp-changing mechanism energizable under control of a monitor circuit responsive to lamp flashing to inhibit functioning of the mechanism unless the lamp fails to light in an energizing interval.

It is another object of the invention to provide a photoelectric detector means to monitor the light output of a flashing lamp and responsive to the failure of such light

2

output to control a motor to cause a multiple lamp turret mechanism to be revolved to advance a new lamp into the flashing circuit.

It is a further object to provide a simplified control for lamp changing mechanism wherein a transistor switching stage periodically energizes a solenoid winding whose armature is coupled with pawl and ratchet drive means to advance the mechanism in response to detection by photoelectric means of non-emission of light by the lamp.

It is a further object to provide a control for motor driven automatic lamp changing mechanism associated with an intermittently energized lamp wherein the light output of the lamp is monitored and actuation of the mechanism is inhibited when the light output during the flash interval is adequate.

Yet another object is the provision of low cost and efficient monitor means for detecting the light output of a flashing lamp and for controlling energization of simple and reliable solenoid powered pawl-and-ratchet driven lamp changing mechanism during the flash interval in response to detection by the monitor of a lamp failure condition.

Other objects and features will become apparent in a careful reading of the following description of the invention and of practical means of carrying it into effect and by study of the accompanying drawings, in which,

Figure 1 is a schematic circuit diagram of a complete lamp flasher with changing mechanism operative according to the invention;

Figure 2 is an elevation view partly in cross section of a lamp turret, a complete flashing light assembly showing a lamp turret, Fresnel lens and control devices;

Figures 3a and 3b are graphs relating keying waveform, lumen output, and monitor responses of the apparatus of Figures 1 and 2;

Figure 4 is an alternative corrective circuit for the monitor amplifier; and,

Figure 5 is an enlarged cut-away elevation view of the mechanical drive for a lamp turret of Figure 1.

An economical and relatively low cost flasher system having daylight-responsive inhibiting means to discontinue flashing when ambient light rises above a predetermined level is described and claimed in applicant's copending application entitled "Lamp Flasher With Daylight-Responsive Inhibiting Means," Serial No. 657,365, filed May 6, 1957. The operation of the circuits and devices of an embodiment described in the related application, which is incorporated in Figure 1 of this application, is included here to assist in more fully comprehending the present invention. Briefly, a pair of transistors TR1 and TR2 preferably PNP junction type have their collectors and bases cross-connected by relatively large capacitance means C1 and C2; each base is shunted to its respective collector by individual shunt resistors, R3 and R4, with individual resistors R2 and R5 in series with the collectors whereby with emitters positively polarized by a source of supply a multivibrator operation is achieved with one transistor switched to fully "on" state while the other is biased "off" for a predetermined duration, and thereafter a reversal of states ensuing. The circuit is freely running as long as operating voltages are applied. By arranging that capacitor C2 is the smaller, the "on" time for TR2 is made to be a fraction of the recurrence period, the value of shunt resistor R4 being adjustable to control the flashes per minute switching rate.

The keying waveform appearing on the collector of TR2 may be examined by reference to Figure 3a, wherein substantially full supply voltage potential appears as TR2 is duly biased "on" during the interval F, and substantially negative supply potential appears during the

3

remainder of the recurrence period T. During the interval F no current flows in the low-valued coupling resistor R7 out of the base of relaying stage transistor TR3, hence this stage is switched "off." There is therefore substantially negative supply potential at the collector end of the coupling resistor R9 which is also of low value hence stage TR4 is strongly biased "on." The latter is preferably a relatively high current type of transistor whose emitter passes the total of all the base currents of the switching stage comprising TR5, TR6 . . . TRn connected in parallel. For economy of supply current, the base current of the switching stage group of transistors is held substantially at zero by interposing the bias cell 27 and its shunting resistor R20 between R12 and the bases, as more fully described in the aforesaid co-pending application. Cell 27 opposes the supply to polarize the bases positively and thereby minimizes current.

A group of lamps which may be four or any other convenient number, of which but 12 and 12' are indicated in Figure 1, have one terminal of their filaments connected to the common collector bus of the keying stage and their individual other filament terminals connected to corresponding commutator segments of which 16 and 16' are indicated.

In the position shown for the lamp turret a fixed wiper 15 connected to negative supply bus 14 completes the flashing circuit through lamp 12 by way of the emitter-collector paths of the switching stage, from positive supply bus 13. Accordingly, as the keying stage is switched on during flash interval F, the lamp filament lights and thereafter remains dark throughout the remainder of the recurrence period T.

During flash interval F, positive potential is applied from the collector bus 25 of the switching stage to a lead 29 which provides positive supply to the monitor amplifier group of transistors TRA, TRB, TRC, and TRD. Photocell 17 which is of the type that generates a potential difference between its terminals 18, 19 when light is incident upon it, has its negative pole 18 directly connected to the base of TRA and its positive pole to the base of TRB. A type of cell is preferably chosen which is able to deliver at least a fractional part of a volt output in response to the full light output of the lamp 12, when cell 17 is mounted adjacent to the lamp base.

In the dark state the cell is passive and exhibits only a series resistance indicated by the dotted outline of R21. The resistance appearing between the base of TRA and ground or negative supply is greater than that between the base of TRB and ground by the value of R21. Accordingly if the emitters of the stages were biased positively, base current would tend to flow from TRB to bias it "on" while TRA would be biased "off" due to substantially zero base current.

When lamp 12 is energized and if it is functioning correctly so that substantially full lumen output is delivered as in Figure 3b, the monitor cell 17 generates an output so that positive voltage is applied to the base of TRB and a negative voltage to the base of TRA. The conductor 29 is made positive in this interval by virtue of the switching stage being fully "on," so that base current flows in TRA. TRB is strongly biased "off" due both to the cell voltage appearing on the base of TRB and to the fact that the collector of TRA assumed substantially the full positive potential of lead 29. Therefore the stage TRC is strongly biased "on" and TRD is biased "off" during the interval. No pulse of current appears in the winding of electromagnet 20 and armature 21 does not actuate pawl 22 and drive ratchet 23 and turret 37 of the changer mechanism. At the end of the flash interval the potential of lead 29 falls to zero and disables the monitor amplifier.

Should lamp 12 fail as for instance in the event of disintegration of the filament for any reason, cell 17 would not be illuminated by a light flash during interval F,

4

with the consequence TRA and TRC remain biased "off" while TRB and TRD are biased "on" during the interval. Armature 21 of the electromagnet 20 is pulled down against the force of restoring spring 30 causing ratchet wheel 23 to move under action of pawl 22 by one tooth distance. At the termination of the interval armature 21 is restored. Turret body 32 is coupled to pinion 24 on the shaft of ratchet 23 for mechanical drive thereby so that in each successive interval the group of lamps is advanced by an increment, eventually bringing another segment and lamp, for example segment 16' and lamp 12' into the circuit. With the successful restoration of flashing by the substitution of a new lamp, the output of stage TRD of the light amplifier is inhibited and electromagnet 20 is not energized.

The waveform of lumen output with time by an energized filamentary lamp such as 12 shown in Figure 3b does not coincide with the keying wave form of Figure 3a due to the finite time or delay interval  $\Delta F$  required for the filament to heat up to a light-emitting temperature. The delay interval is reducible by choice of a lamp with a filament of relatively small mass. The application of the positive voltage keying wave to the stages TRA, TRB and TRC is deliberately delayed by an interval of at least the length of  $\Delta F$  by interposing resistor R13 in series with lead 23 ahead of these stages, and by use of a shunting capacitor C3, to provide a finite build-up time before appreciable positive voltage is applied to the emitters of these stages. The light output continues shortly after the end of each flash interval F, however electromagnet 20 cannot operate after positive voltage has been removed from lead 29.

An alternative embodiment is shown in Figure 4 wherein stage TRD is shown, having a delay capacitor C4 connected from the positive bus to the base. Charging current through the capacitor flowing in resistors R19 and R15 to negative supply effectively biases the stage "off" until the capacitor has reached a degree of charge, the delay being arranged to be not less than the build up time for full lumen output.

A practical embodiment of the invention is described with reference to Figures 2 and 5. A lamp turret 32 having a capacity of four lamps has its axle journaled in a frame comprising the upward extension of a casting 33 having a gear train housing closed by cover plate 55 and a back bearing plate 36. The lamp turret assembly is supported with the frame base 37 secured to a thick disc cap 40, as by screws or other suitable fastening means, thereby securing a strap 38 to the assembly. Stud bolt means 39 passed through the ends of the strap are threadedly engaged in holes tapped into the main lamp base 10. A Fresnel type lens 11 is carried upon a sturdy metal base ring 50 having a series of captive bolts 51 spaced about the circumference, the base seating on bevelled face 49 of the lower housing. Suitable resilient sealing gasket means are provided to prevent dust and moisture from gaining entry when the bolts 51 are tightened down upon the slotted ears 52. For convenience the upper lens assembly is made to pivot upon the lower housing, hinging on pin 56 which is received in the hole 57 of the base shoulder provided.

Base 10 may be supported in any suitable manner upon a buoy, tower, mast or other vertically extended structure, negative supply lead 14 from the battery being grounded to frame and positive lead 13 into the bore preferably through a sealing gland received in the side of the base.

A daylight-sensing photocell 34 is housed on the side of the back gear train plate 55 and is preferably shielded from direct lamp illumination as by a blackened sheet metal rectangular structure 35 built around it. The cell receives ambient illumination incident upon it as is transmitted inwards through the lens 11. The disabling relay M is supported on the amplifier chassis 43 which depends from the lid 40 and is hermetically enclosed in the cup

5

41, shown in cut-away section. O-ring seals are provided between the upper flaring part of can 41 and the bevelled face of lid 40, and wing nut means (not shown) attached to the sides of the can are provided, to be received in slots 42 in ears projecting laterally from the upper part of lid 40. Light flash monitor cell 17 is supported adjacent the base of the operating lamp, indicated in Figure 5 as lamp 12, preferably being set at an angle of 45 degrees with the vertical and facing upwardly towards the filament, so as not to obstruct light which is radiated substantially uniformly through the equatorial plane of the lens. A sheet metal tab supporting structure 28 is suitably affixed upon the upper part of the casting 33. The series of lamps are detachably supported in any convenient manner upon the turret block 32, the support herein being indicated as pairs of screw heads 54, under which the lamp sockets are received and against which they are pressed outwardly by spring tension of the base contact.

Lamp energizing circuit leads are taken from the switching circuit by way of binding posts 47, 48, the latter being grounded to the frame and the former being insulated and connected to suitable wiper means 15 (not shown) for contacting segments located on the turret on which the lamp filament leads terminate.

A solenoid stepping motor of conventional type is shown in Figure 5, operating ratchet wheel 23 by means of a pawl spring 22, wherein the turret 32 is driven by means of the gear train comprising gear 46, pinion 45, gear 44, and pinion 24. At each energization of the solenoid 20, the armature 21 pulls down and advances pawl 23 by one tooth distance. A lesser or a greater number of gears and other gear ratios may be used depending on the particular application in which the lamp is used. In the present instance, where the flashing rate is approximately 12 flashes per minute, a new lamp may be restored into the circuit in less than half a minute.

The invention extends also to motor means other than the solenoid-actuated pawl-and-ratchet stepping motor shown. The latter is preferred as completely avoiding any moving contacts, but it is to be understood as entirely an equivalent to employ a brush type D. C. powered rotary electric motor, whose shaft is linked in driving relation to turret 32 by means of a suitable gear train.

Where the number of lamps carried by the turret is small, a spring motor of only such capacity as would suffice to rotate the turret only a few revolutions and powered adequately for at least one revolution may be employed, in conjunction with a solenoid actuated brake, stop, or dog to release the stop when a new lamp is to be substituted. Such spring motors and controls are believed to be well understood and suitable devices for driving a turret may take many forms.

The invention extends moreover to devices wherein the lamp energization is intermittent but the length of a flash may be several hours or even days, provided that the means controlling the motor operation is itself powered in common with the lamp energizing circuit, so that the motor is ineffective to drive the lamp changer mechanism except in periods when the lamp is supplied with energizing current.

While the invention has been particularly described with reference to a small type of lamp used in navigational marker lights, it is applicable to a wide range of installations and extends to all signal and illuminating devices as are required to operate reliably in steady or flashing light generating service, on fixed installations or in vehicles such as automobiles, boats and aircraft.

I claim:

1. In lamp changer apparatus of the type comprising a carrier bearing a plurality of lamps, means revolubly supporting the carrier in a frame, drive means associated with the carrier for effecting rotation thereof when the drive means is energized to locate one of said lamps in a reference position, and selector means in said frame

6

for connecting said lamp with an electrical supply, the improvement which comprises the combination of a drive energization control unit, a monitor element disposed adjacent said selected lamp and having a pair of terminals and effective to deliver a unidirectional potential difference therebetween, means to apply said output as input to said control unit, said control unit comprising a first and a second transistor, means connecting the bases of said first and second transistors respectively with the negative and positive terminals of said element, resistor means connecting the collector of the first transistor with the base of the second transistor, a pair of impedance means respectively connected between each collector and the negative terminal of the supply, means connecting the positive terminal of said supply to the emitters in parallel with said lamp, a motor having a winding, means including said motor in circuit with said second transistor for energizing said motor winding when said potential difference falls below a predetermined magnitude, and time constant means included in said motor winding circuit to delay drive energization when said supply is connected.

2. Lamp changer apparatus as in claim 1 wherein said positive supply terminal is connected with said lamp periodically and said motor means comprises a solenoid having an armature, a pawl carried by the armature, a ratchet wheel engaged by said pawl and coupled with said carrier to effect limited angular rotation of the carrier at each periodic energization of the solenoid.

3. Lamp changer apparatus as in claim 1 wherein said drive means comprises a spring motor having an escapement and said motor means comprises a solenoid having an armature coupled with the escapement to effect limited angular rotation of the carrier at each periodic energization of the solenoid.

4. Lamp changer apparatus as in claim 1 wherein said drive means comprises the motor means and the means in circuit with the second transistor comprises one or more transistor amplifier stages in cascade relation.

5. In a signalling device of the type comprising a lamp turret having lamp circuit selecting means, motor means coupled in drive relation with said turret, and electrical supply means for energizing a lamp circuit selected by a said selecting means, the improvement comprising a two-terminal light-responsive generator of E.M.F. disposed in monitoring relation with light produced by said lamp, and control means having said generated E.M.F. applied as input responsive thereto and effective to hold said motor means inoperative when said E.M.F. exceeds a predetermined magnitude and effective to cause said motor means to drive said turret when said E.M.F. corresponds to a light output less than a predetermined light output, wherein said control means comprises a first and a second transistor, means connecting the bases of said first and said second transistor respectively with the negative and positive terminals of said generator, resistor means connecting the collector of the first transistor with the base of the second transistor, a pair of impedance means respectively connected between each collector and the negative terminal of the supply, means connecting the positive terminal of said supply to the emitters in parallel with said lamp, and circuit means connecting said motor means in circuit with said second transistor for energizing said motor winding.

6. In a signalling device of the type comprising a frame, a multiple lamp turret journaled for rotation in said frame, said frame supporting lamp circuit selector means and a solenoid motor means associated in powered drive relation with said turret, for advancing said turret, a source of electric supply, and switching means adapted to connect said source to intermittently energize a selected lamp circuit, the improvement which comprises a two-terminal monitor element generating a D.C. voltage output when exposed to light disposed to receive light from a selected lamp, and control means responsive to an out-

7

put from said element less than a predetermined voltage occurring when said lamp circuit is energized effective to cause the motor to drive said turret, said control means comprising a first and a second transistor, means connecting the bases of said first and said second transistors respectively with the negative and positive terminals of said element, resistor means connecting the collector of said first transistor with the base of said second transistor, a pair of impedance means respectively connected between each collector and the negative terminal of the supply, and circuit means including said switching means connecting the positive terminal of said supply with said

8

emitters in parallel with said lamp, and means connecting the winding of said solenoid between said negative terminal and the collector of said second transistor.

## References Cited in the file of this patent

## UNITED STATES PATENTS

2,054,013	Wallace -----	Sept. 8, 1936
2,097,250	Keith -----	Oct. 26, 1937
2,195,374	Wallace et al. -----	Mar. 26, 1940
2,299,501	Schneider -----	Oct. 20, 1942