



US 20160059163A1

(19) **United States**

(12) **Patent Application Publication**
Kruckenberg et al.

(10) **Pub. No.: US 2016/0059163 A1**

(43) **Pub. Date: Mar. 3, 2016**

(54) **ELECTRONIC INTERFACE FOR WATER FILTER**

Publication Classification

(71) Applicant: **WHIRLPOOL CORPORATION**,
Benton Harbor, MI (US)

(51) **Int. Cl.**
B01D 35/143 (2006.01)
C02F 1/00 (2006.01)

(72) Inventors: **Christopher A. Kruckenberg**,
Newburgh, IN (US); **John W. Morrison**,
Oxford, MI (US); **Peter J. Richmond**,
Berrien Springs, MI (US); **Jeffrey A. Spindler**,
Haubstadt, IN (US)

(52) **U.S. Cl.**
CPC **B01D 35/143** (2013.01); **C02F 1/003**
(2013.01); **C02F 2307/12** (2013.01)

(73) Assignee: **WHIRLPOOL CORPORATION**,
Benton Harbor, MI (US)

(57) **ABSTRACT**

(21) Appl. No.: **14/939,446**

(22) Filed: **Nov. 12, 2015**

A water filter includes a filter unit having a body portion adapted to be rotatably received into a filter head assembly. An engagement protrusion extends from the body portion and is adapted for reception in a complementary receiver in the filter head assembly. An electronic device is disposed on the filter unit having a memory storage unit. A laterally extending key member is disposed on the body portion between the first engagement surface and the second engagement surface. The laterally extending key member is adapted to reposition an interference member from an interference position, whereby the body portion can be fully inserted into the filter head assembly to a non-interference position, whereby the body portion can be fully inserted into the filter head assembly.

Related U.S. Application Data

(63) Continuation of application No. 14/073,145, filed on Nov. 6, 2013, which is a continuation of application No. 13/233,347, filed on Sep. 15, 2011, now Pat. No. 8,580,109.

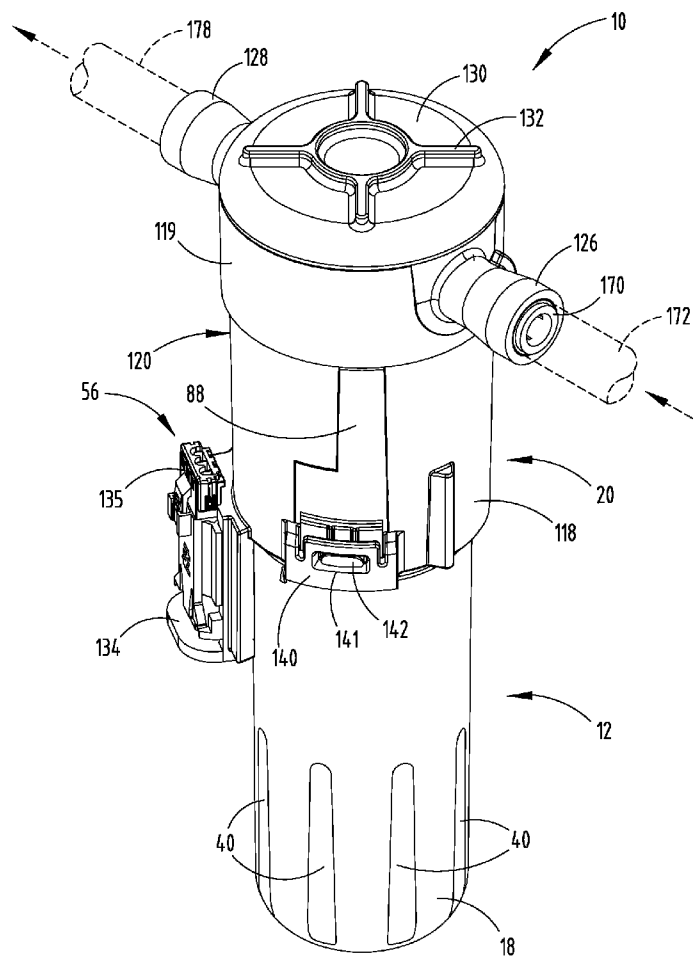

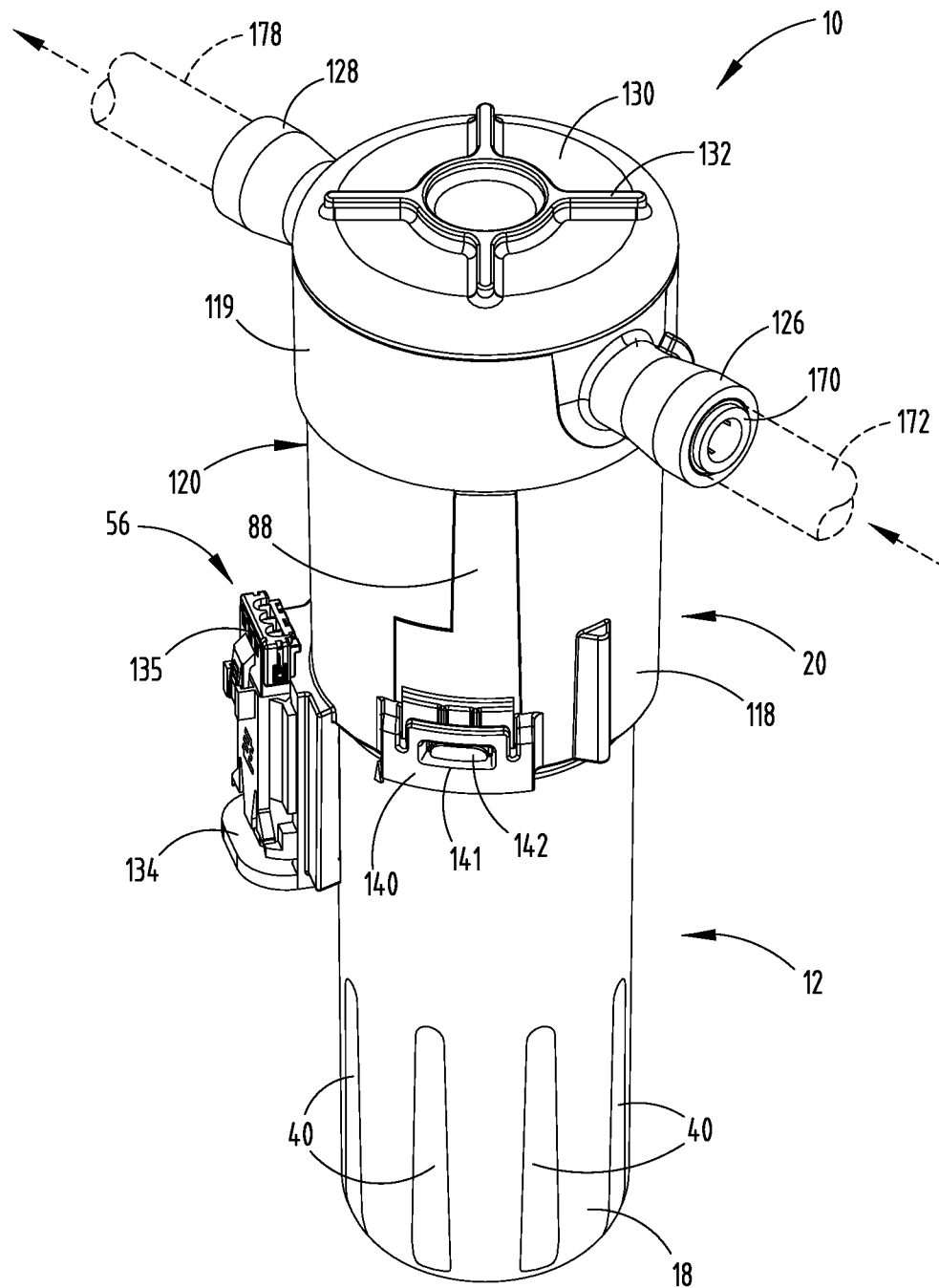

FIG. 1

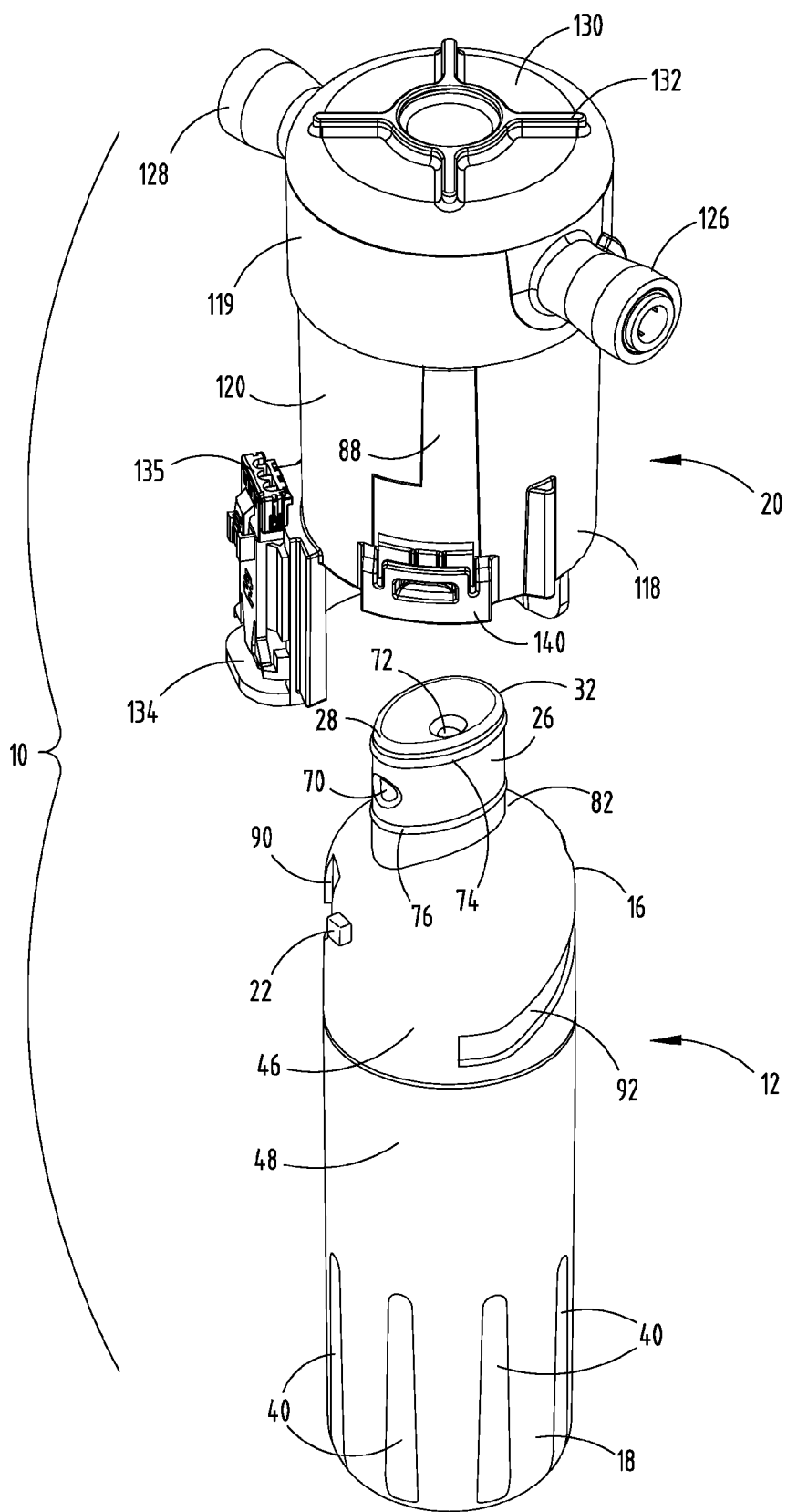
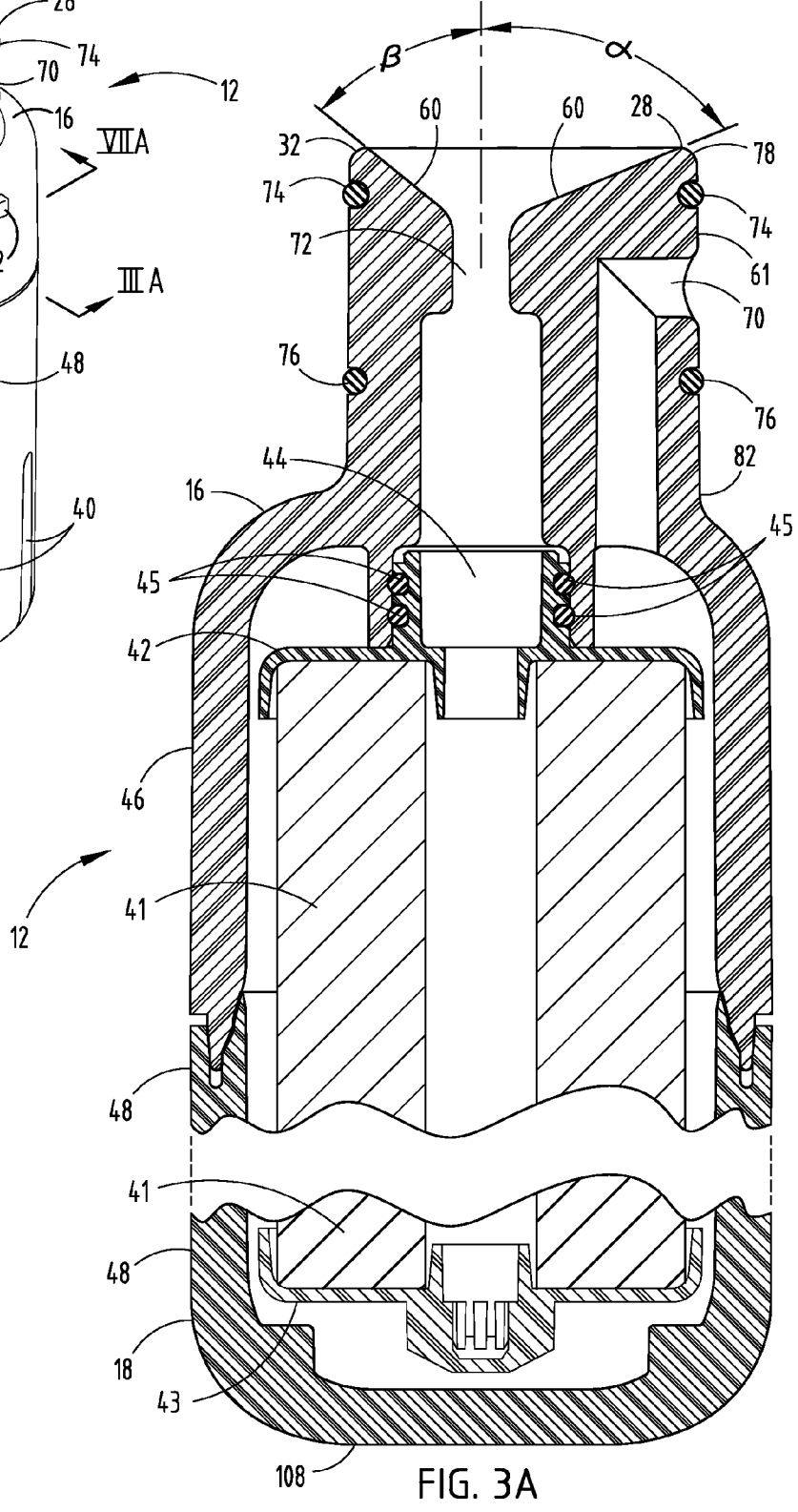
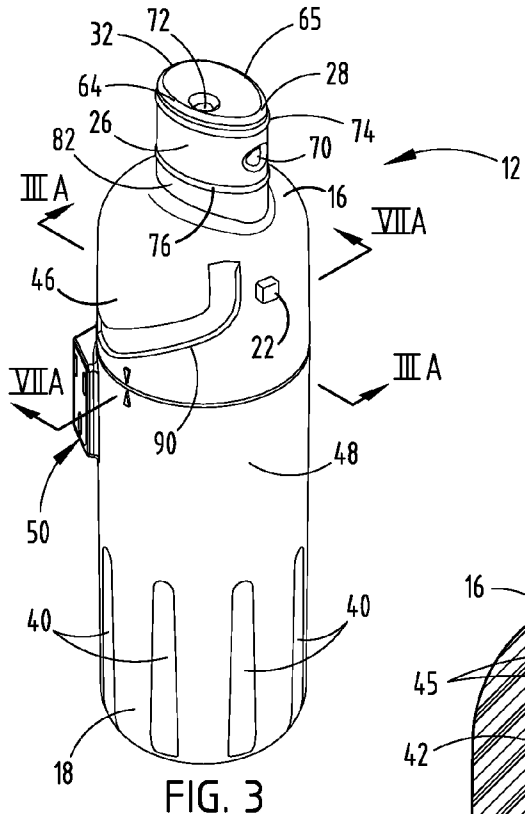

FIG. 2



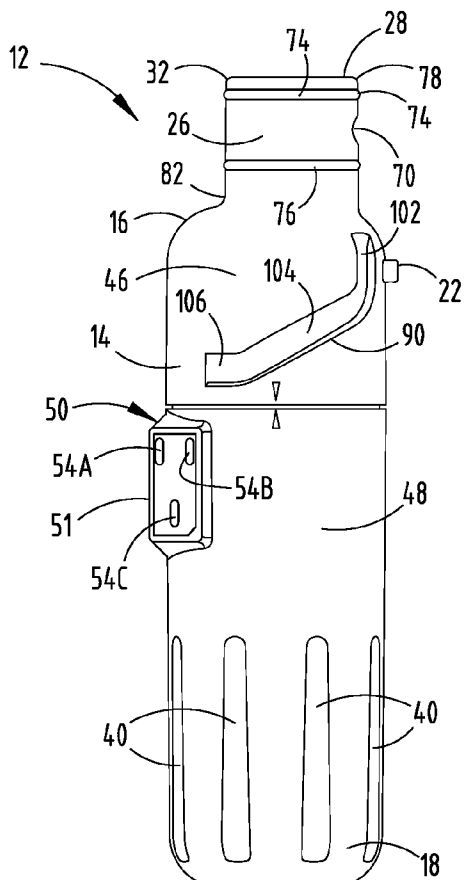

FIG. 4

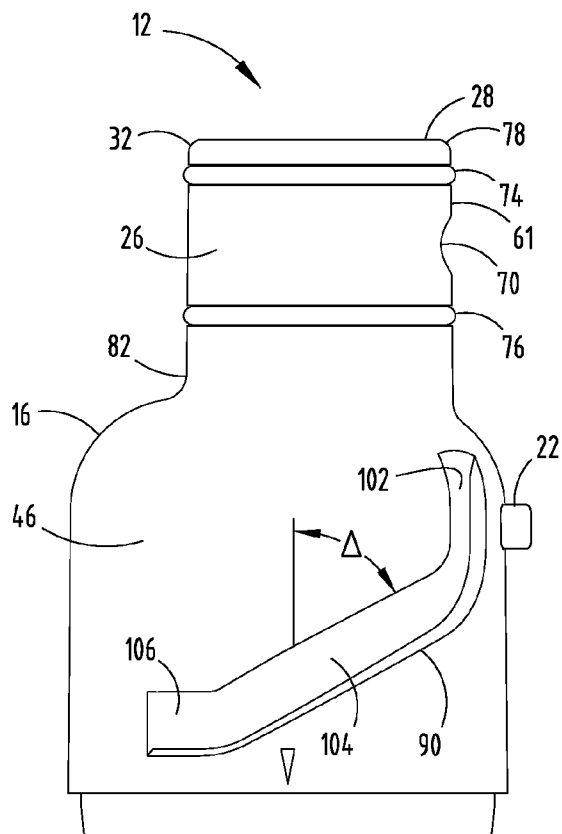

FIG. 4A

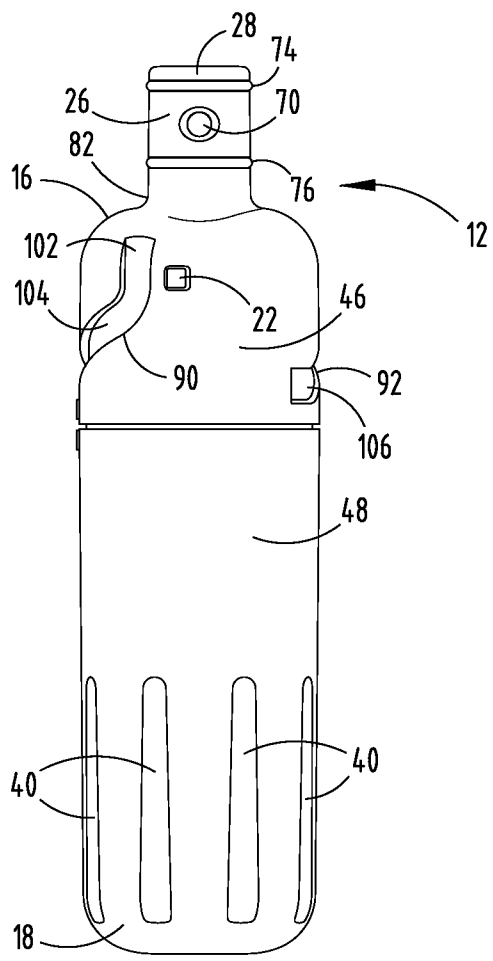

FIG. 5

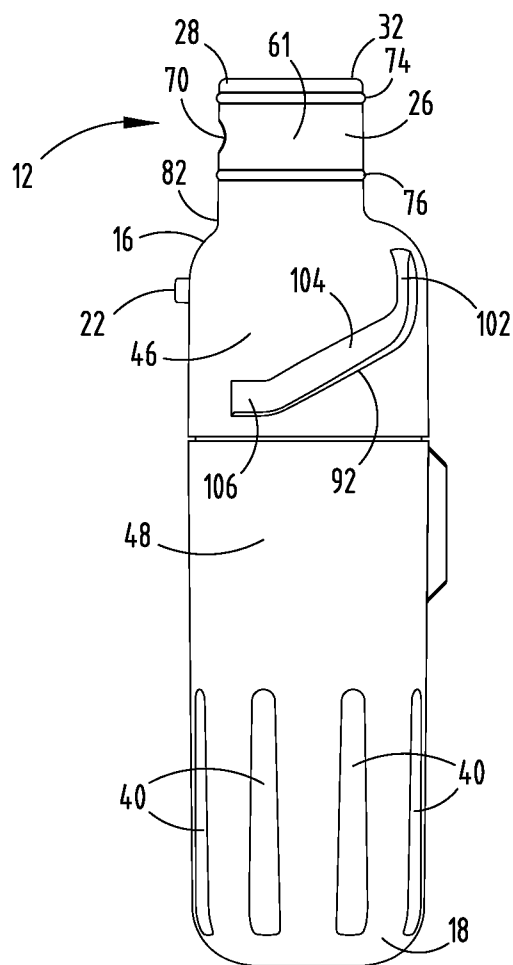

FIG. 6

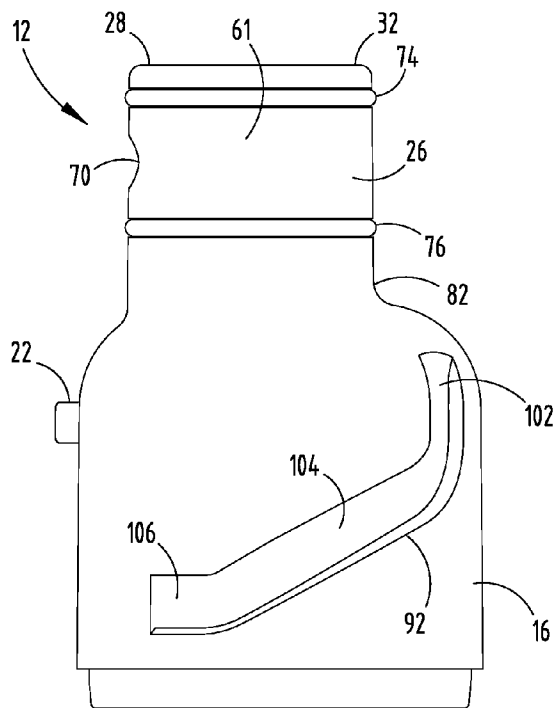

FIG. 6A

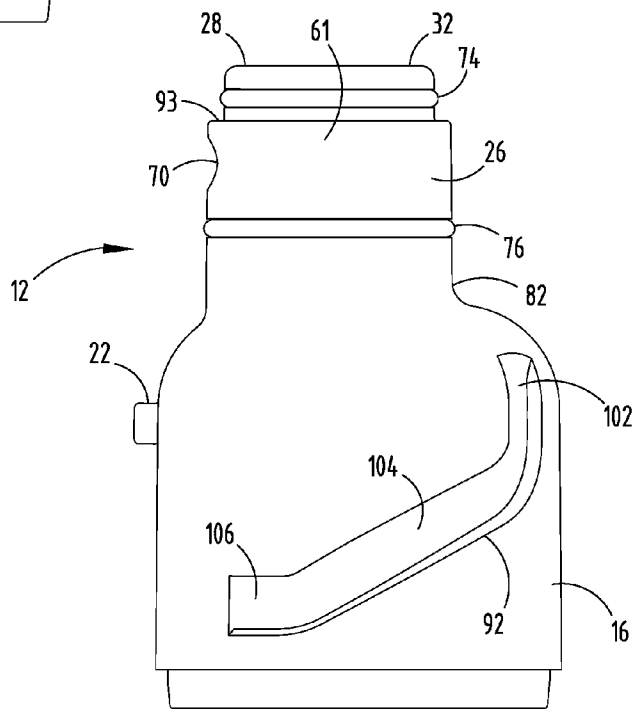

FIG. 6B

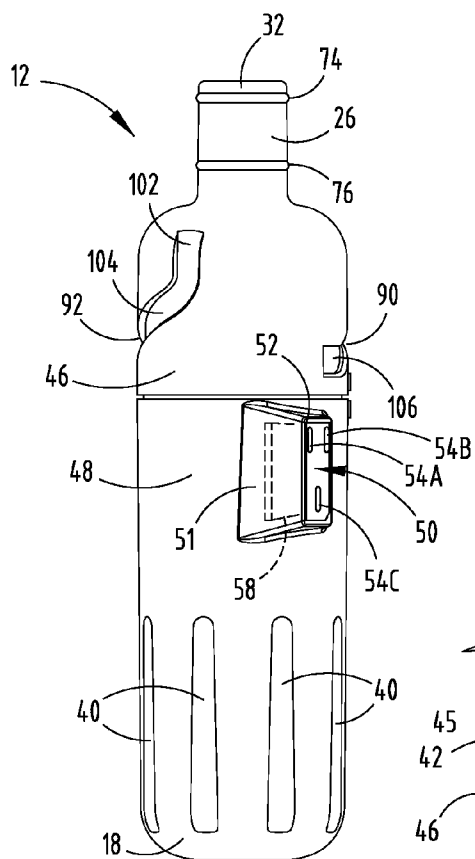

FIG. 7

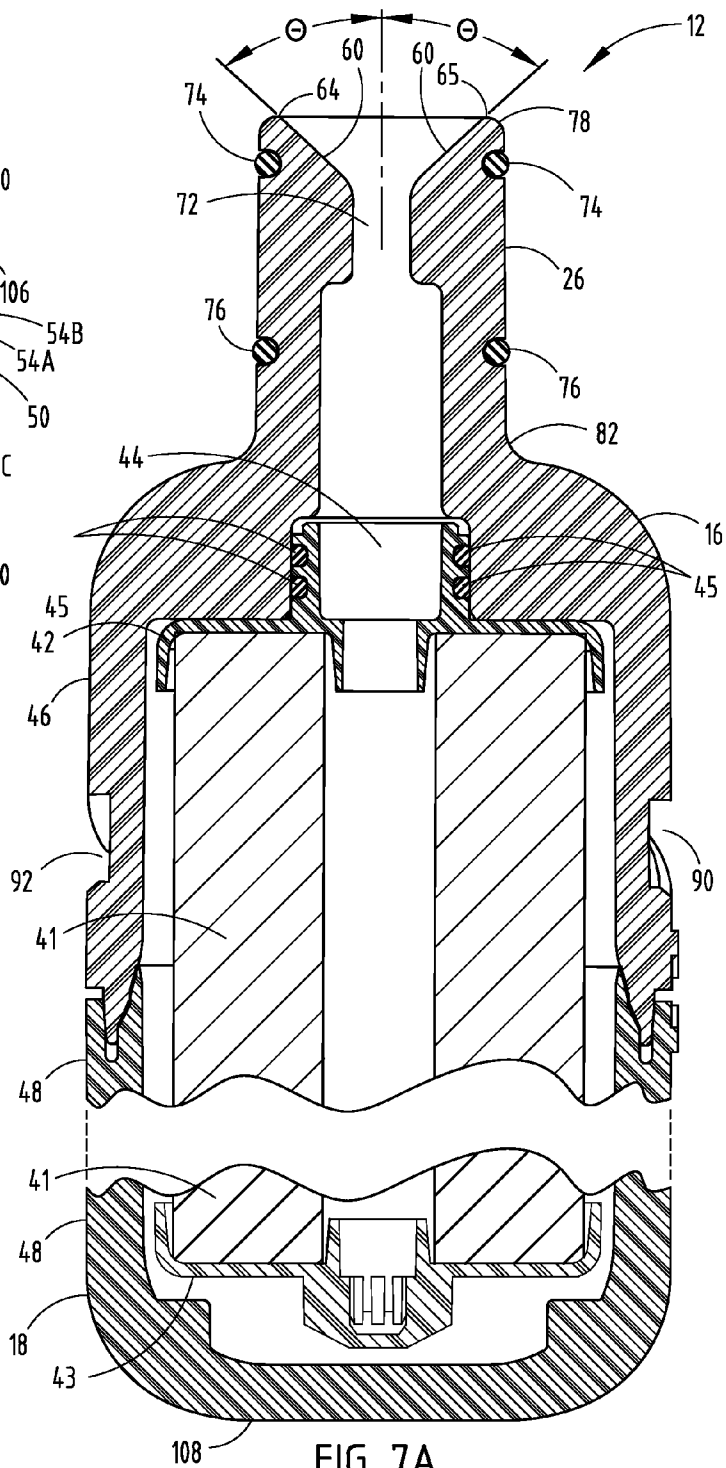
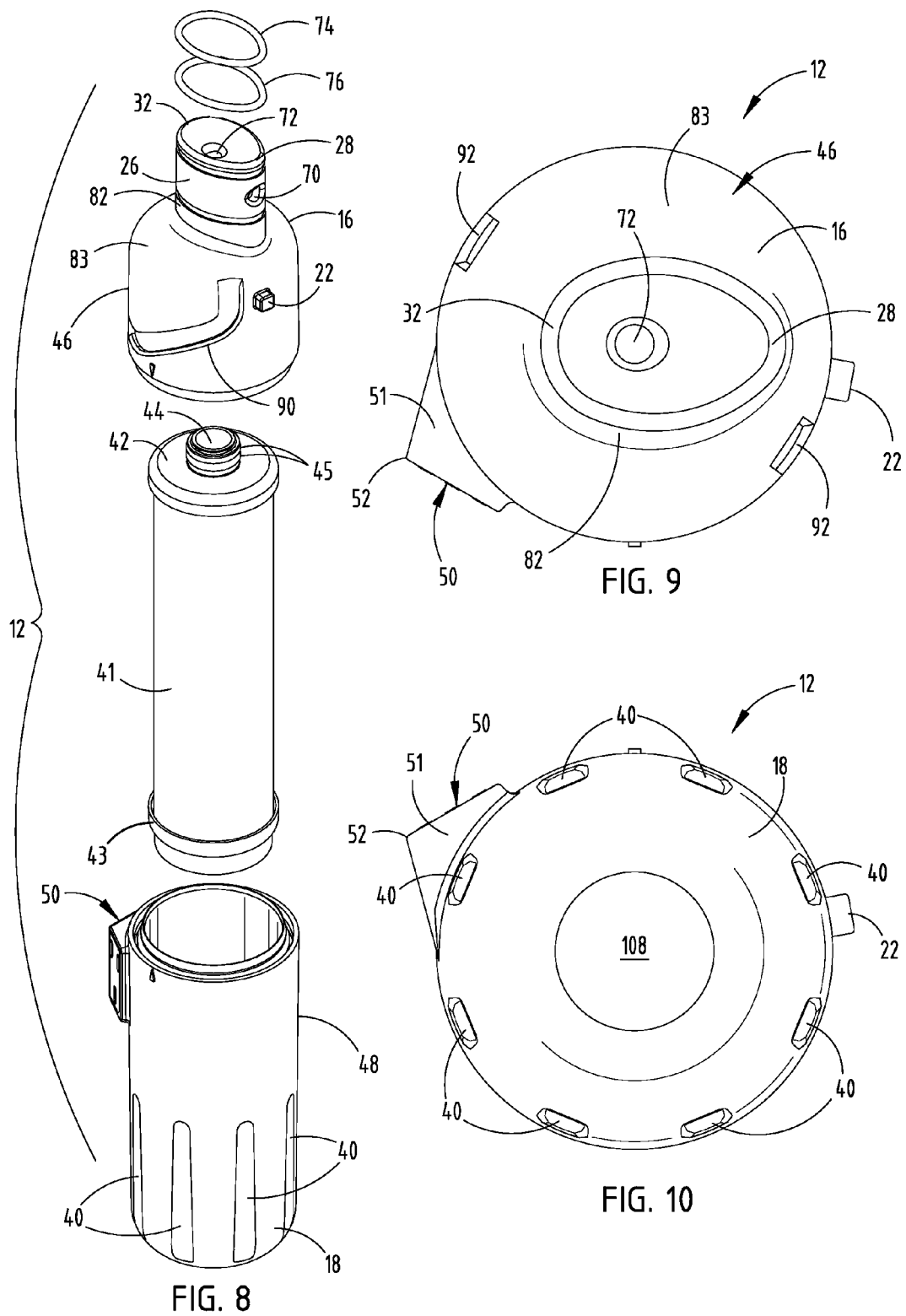

FIG. 7A



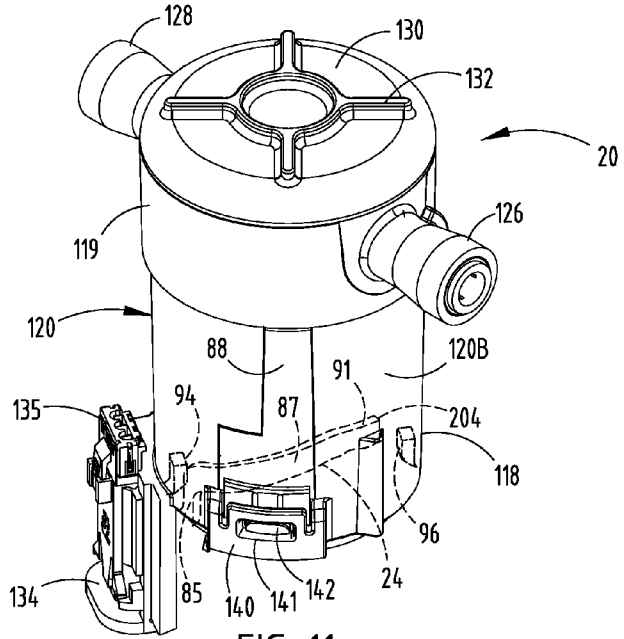

FIG. 11

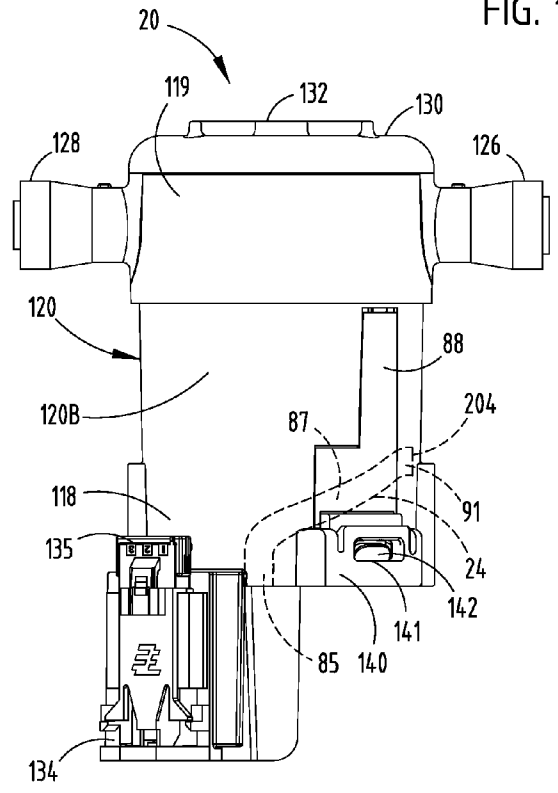

FIG. 12

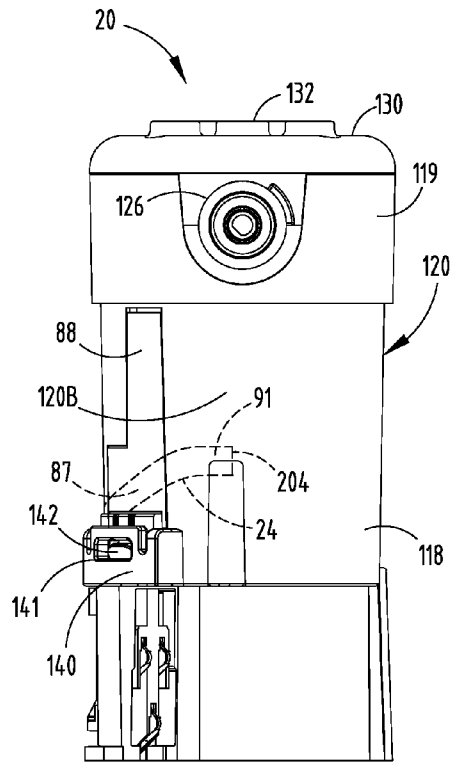

FIG. 13

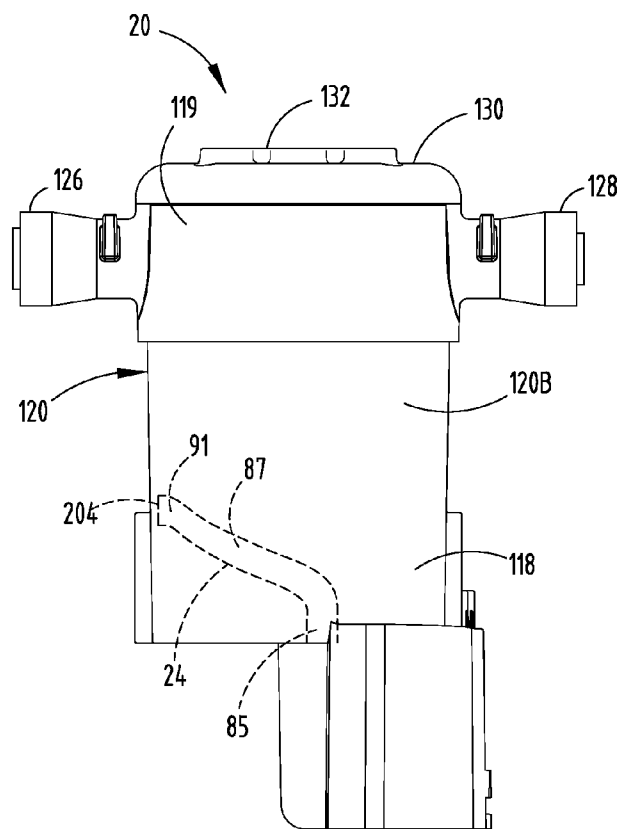

FIG. 14

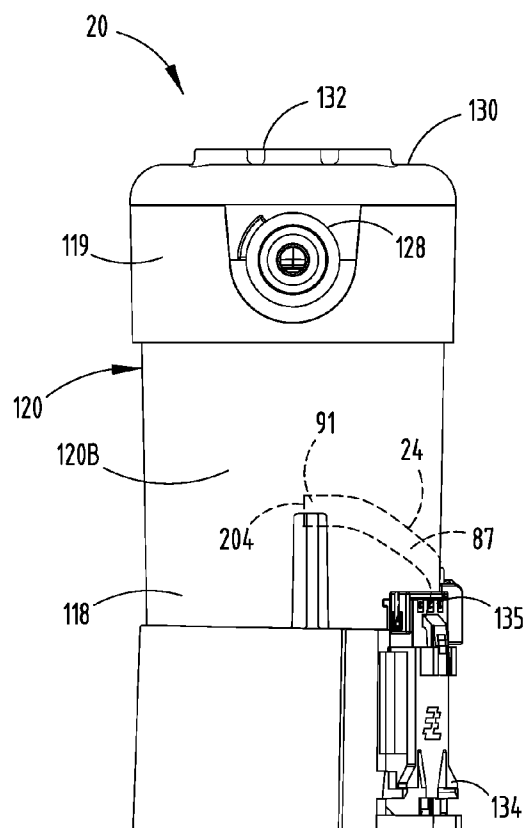

FIG. 15

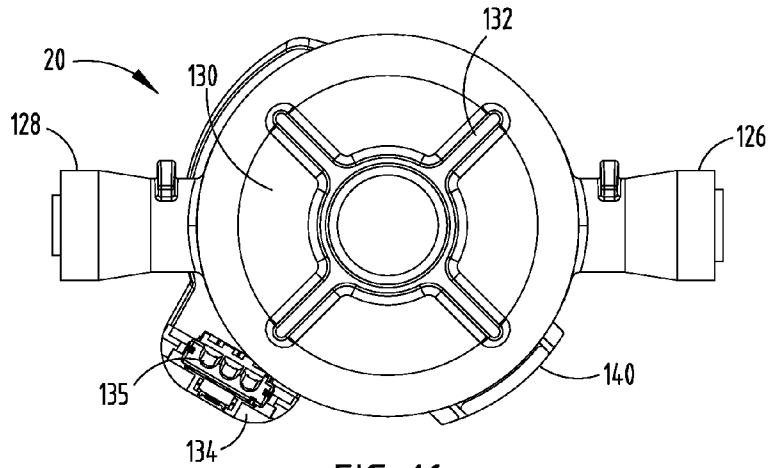

FIG. 16

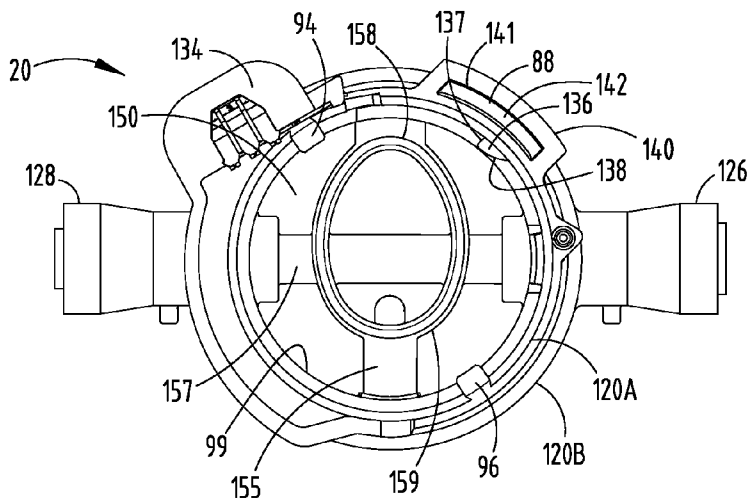

FIG. 17

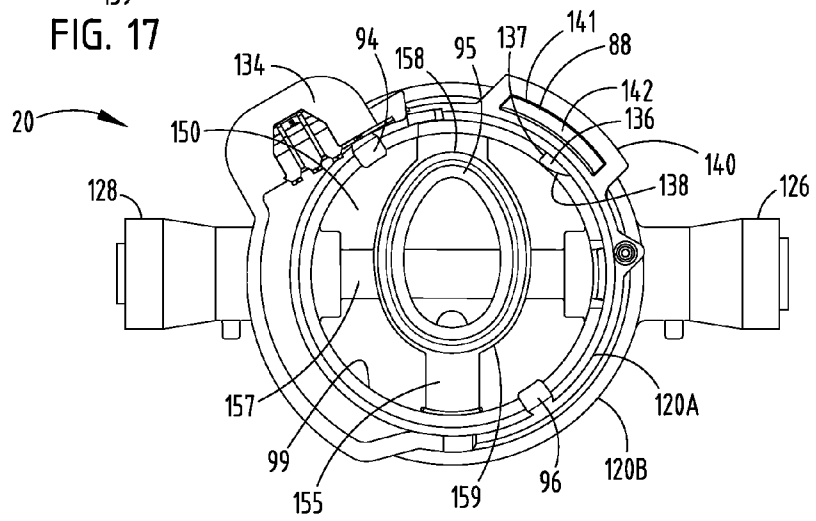

FIG. 17A

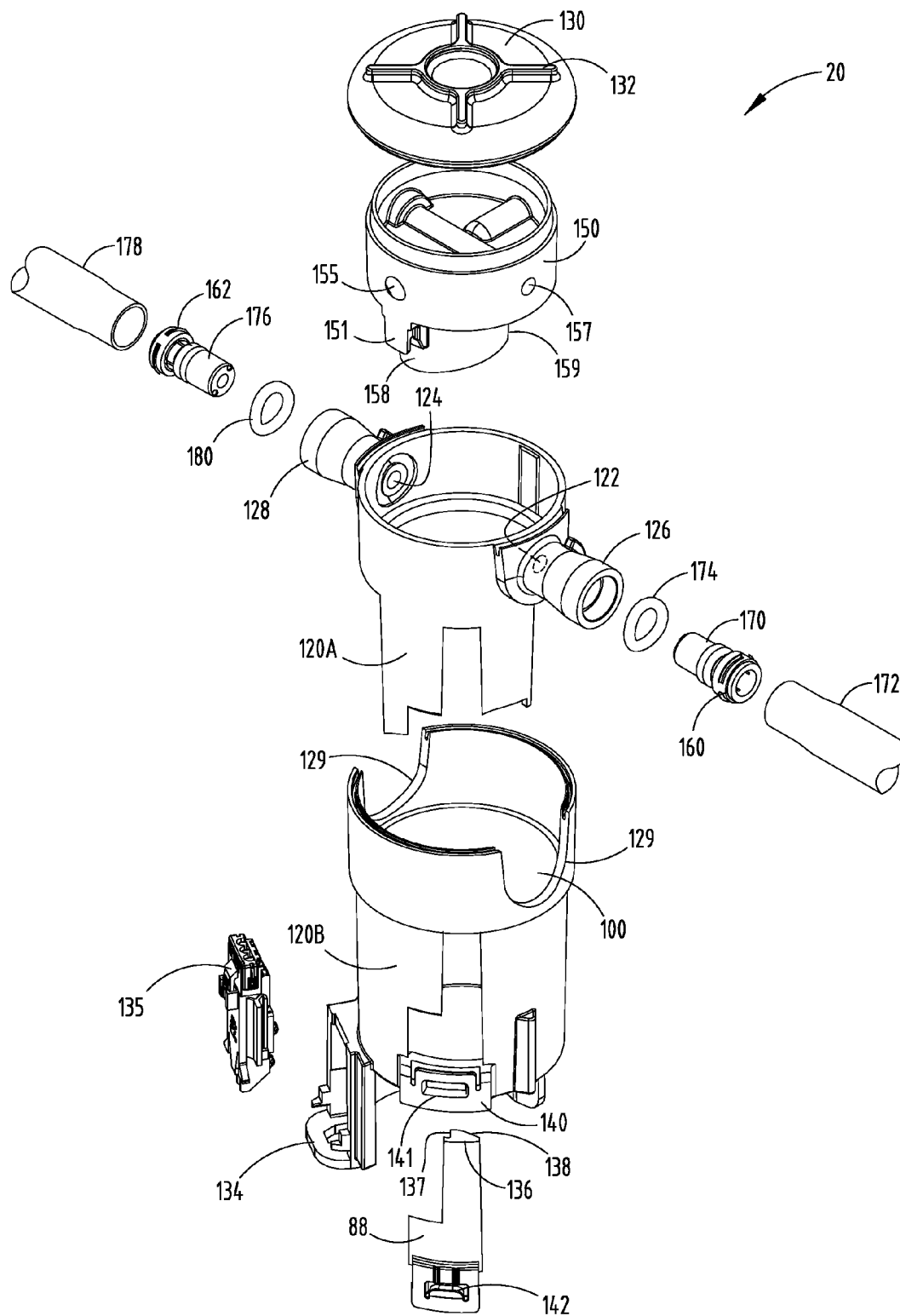

FIG. 18

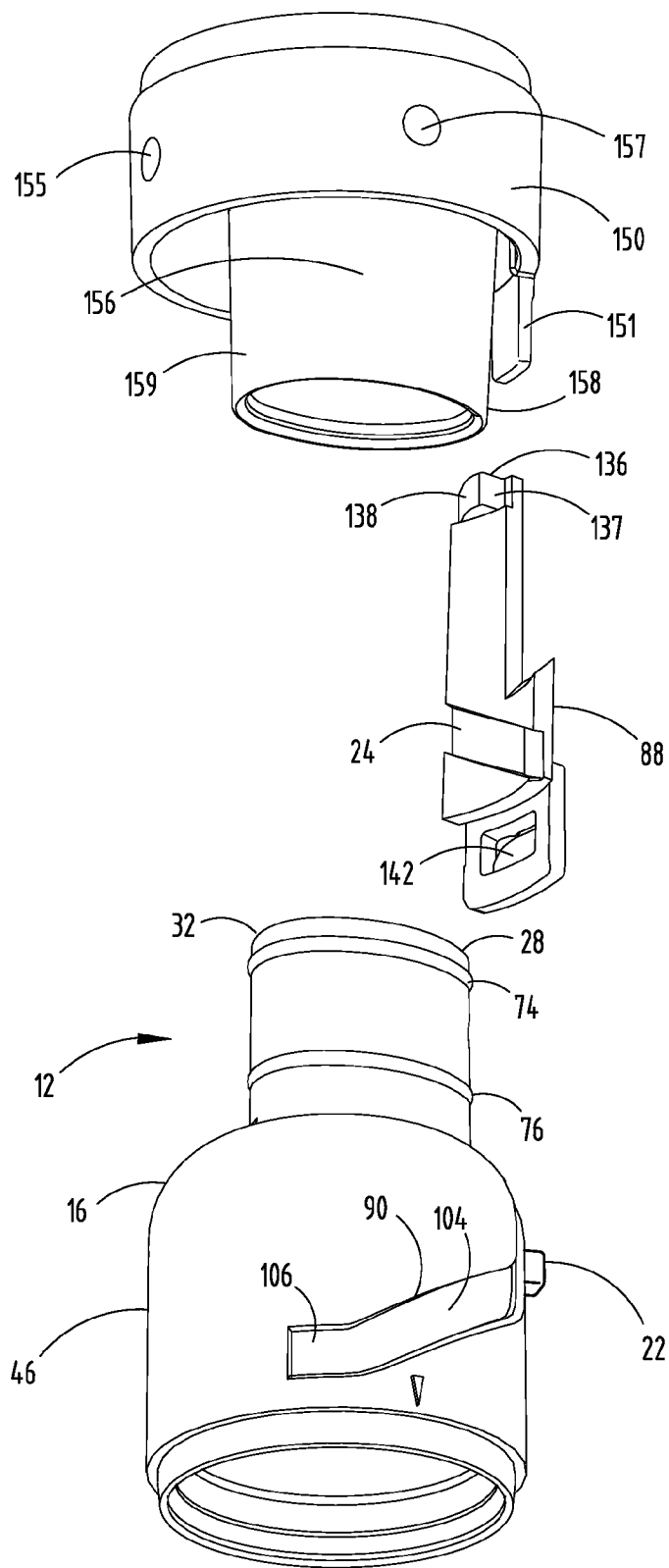

FIG. 19

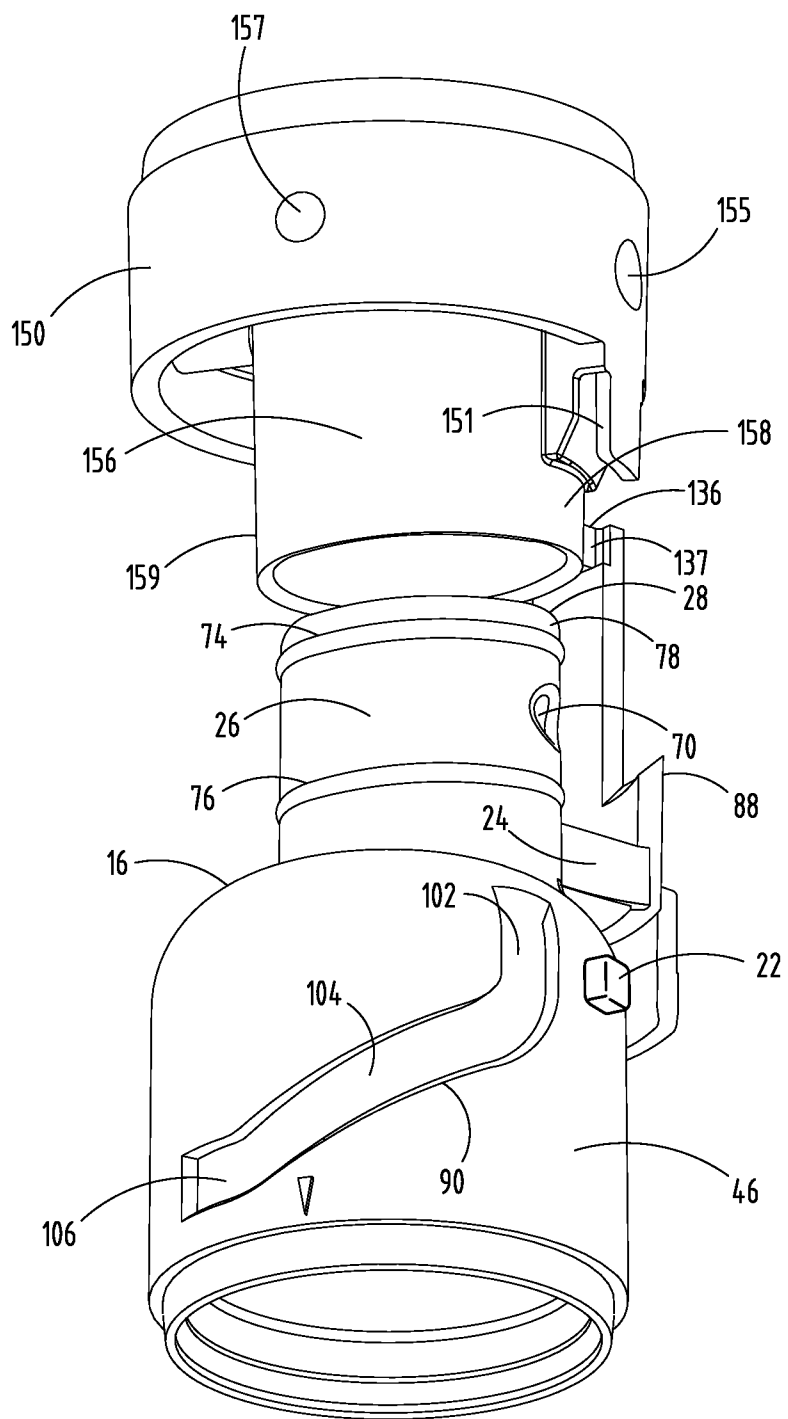
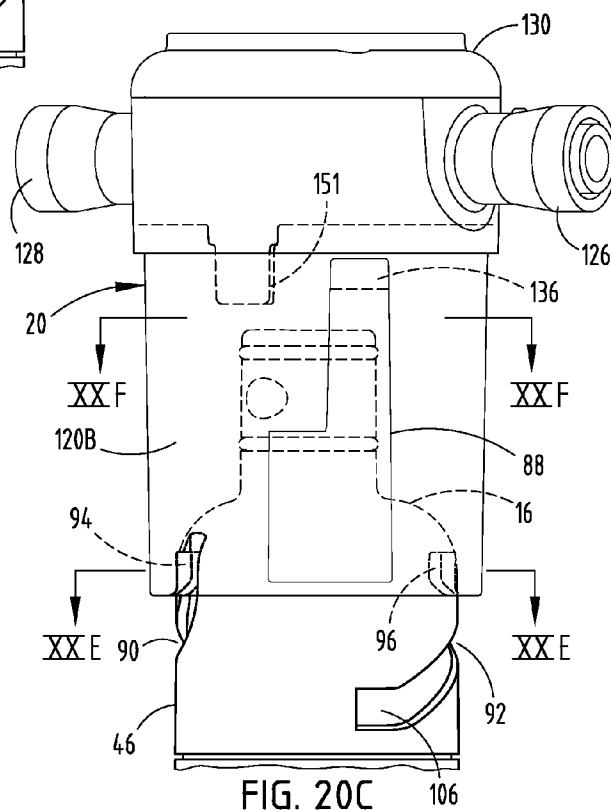
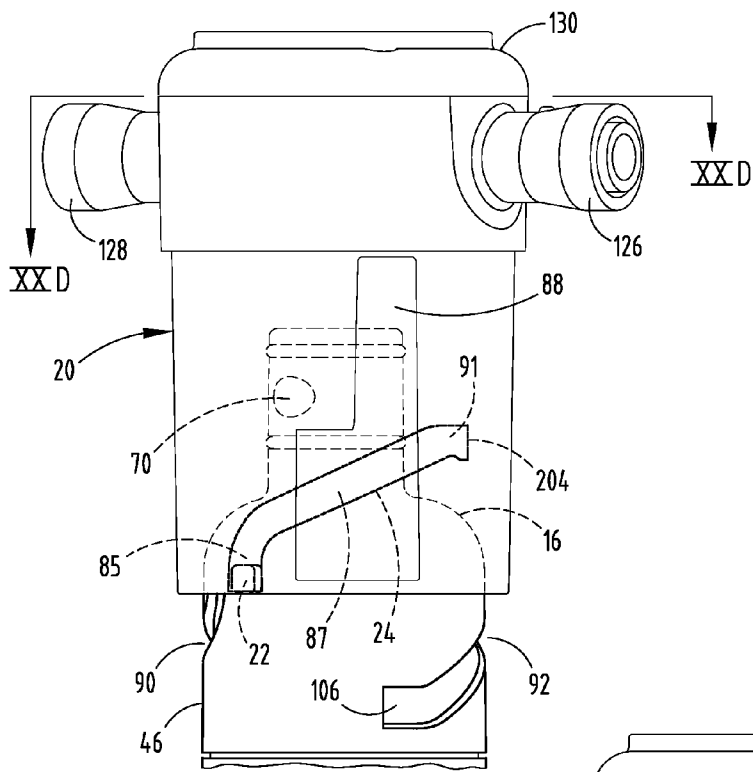

FIG. 20A



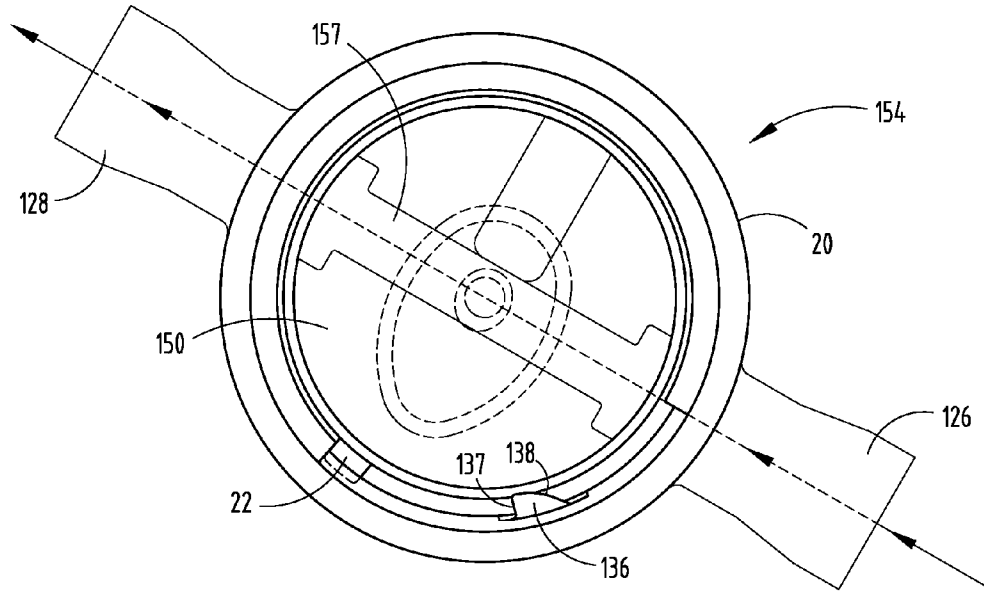

FIG. 20D

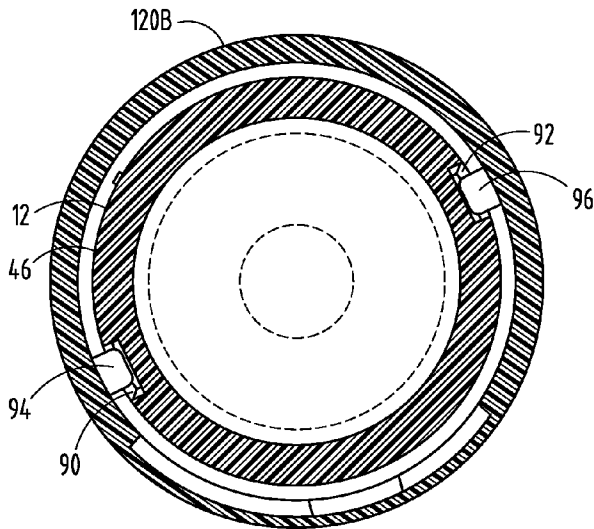

FIG. 20E

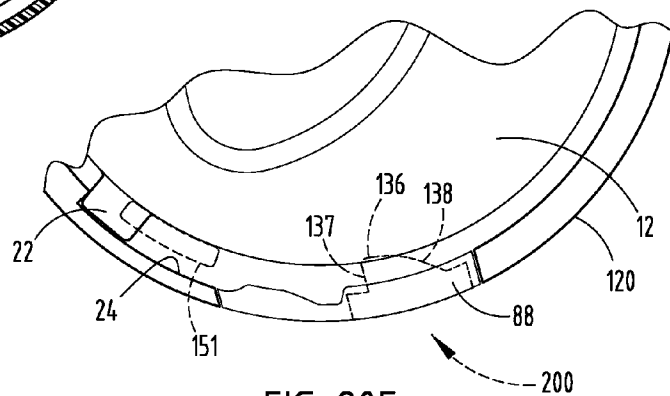

FIG. 20F

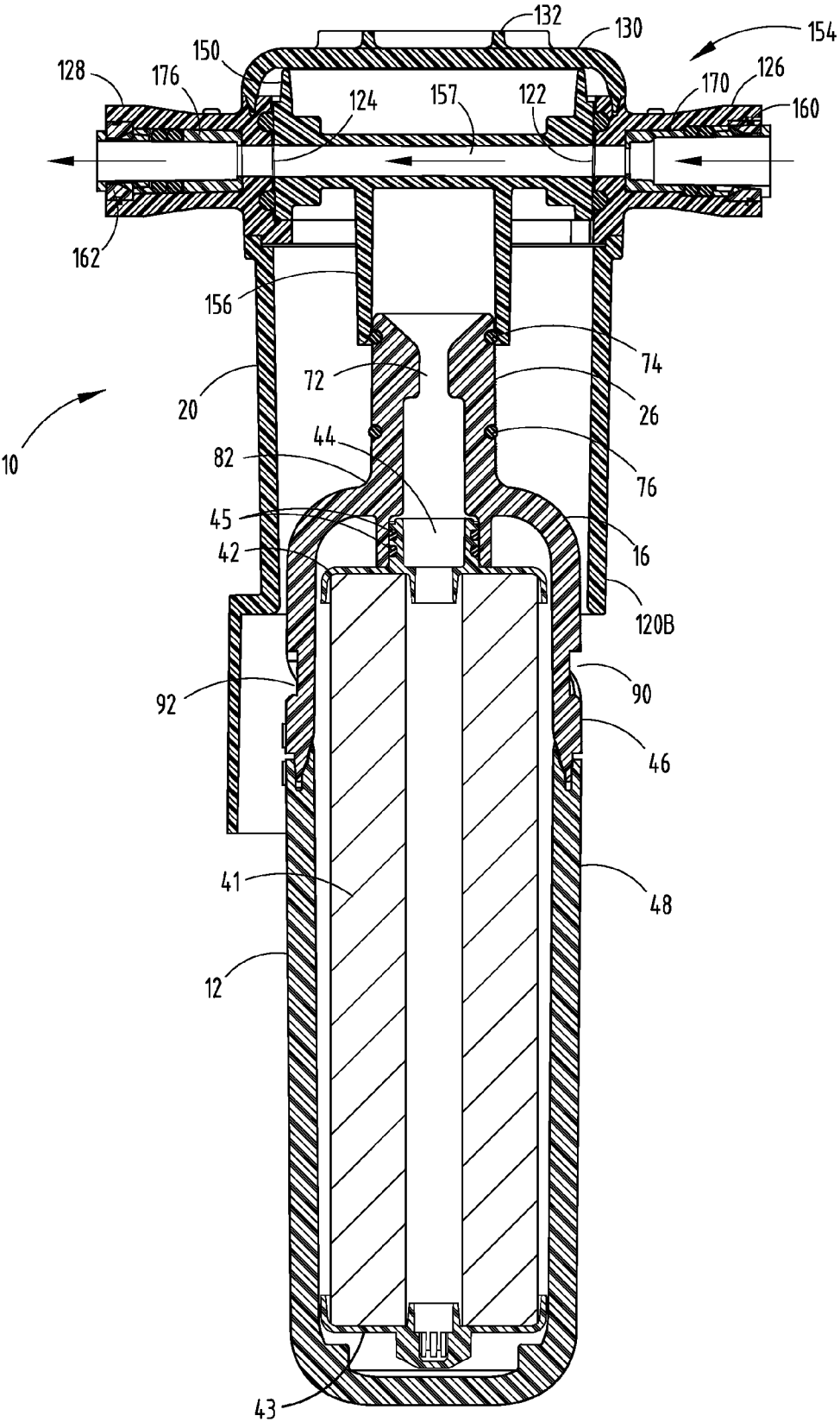

FIG. 20G

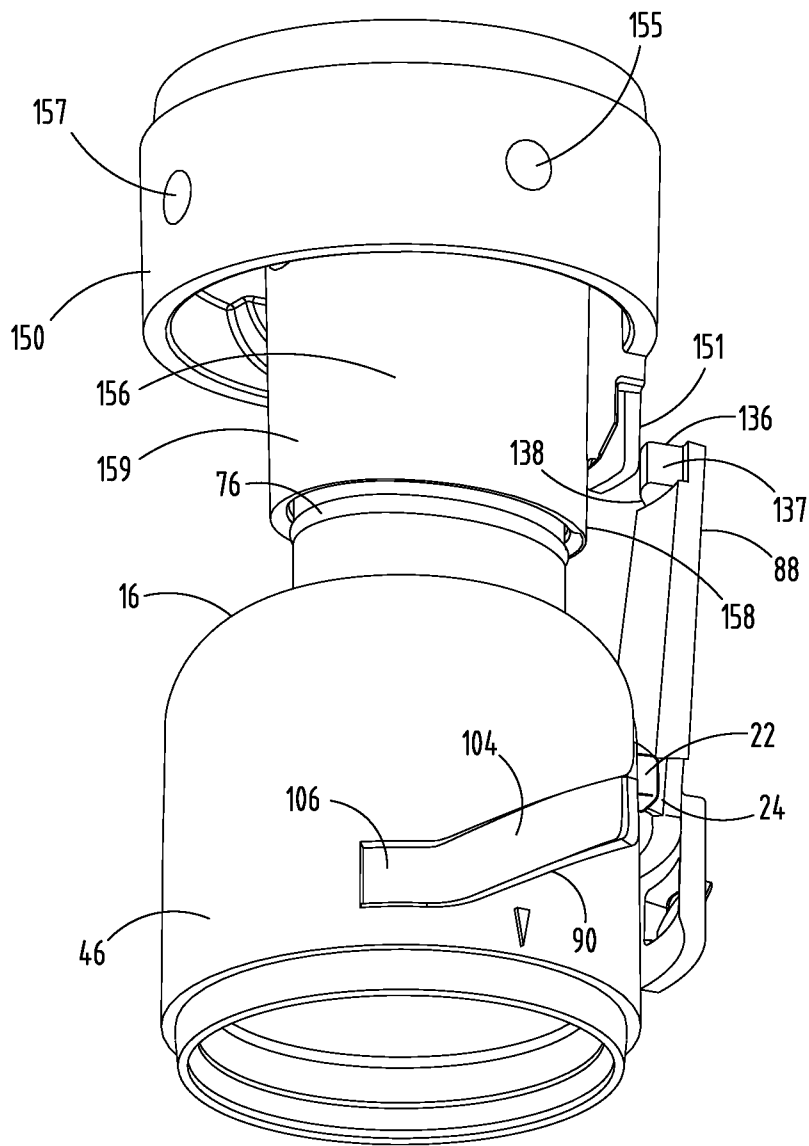

FIG. 21A

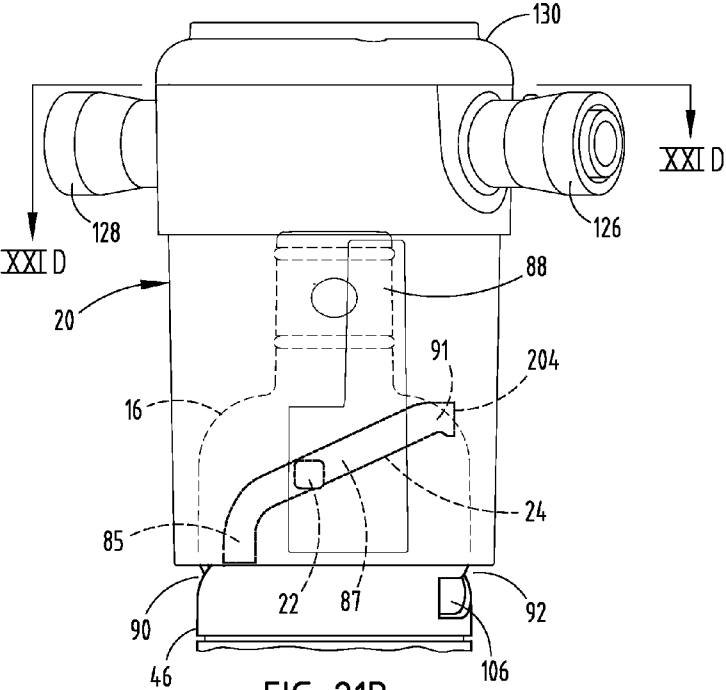

FIG. 21B

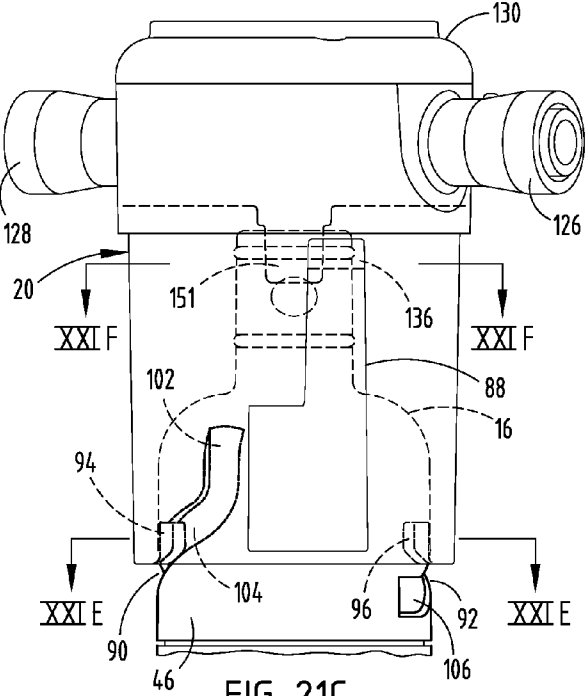

FIG. 21C

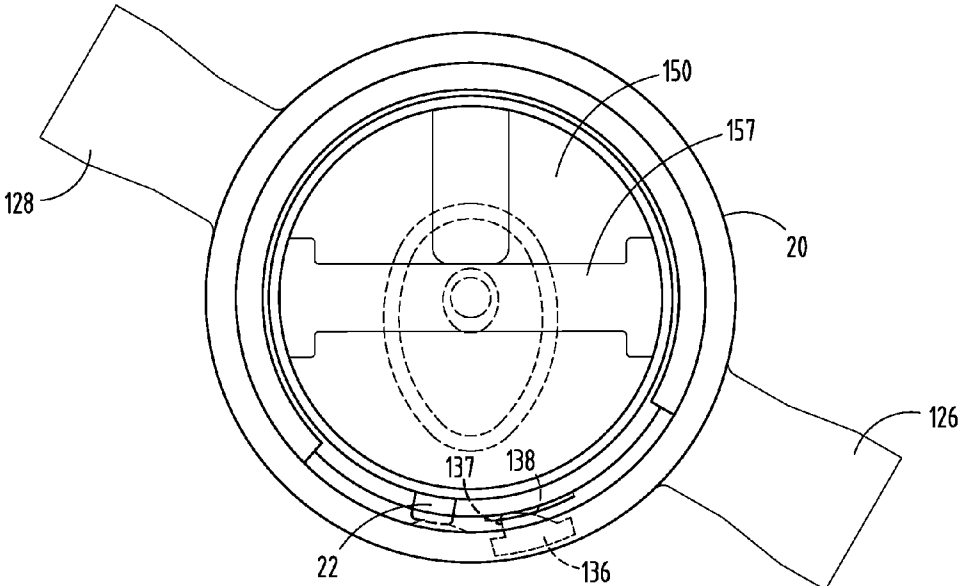

FIG. 21D

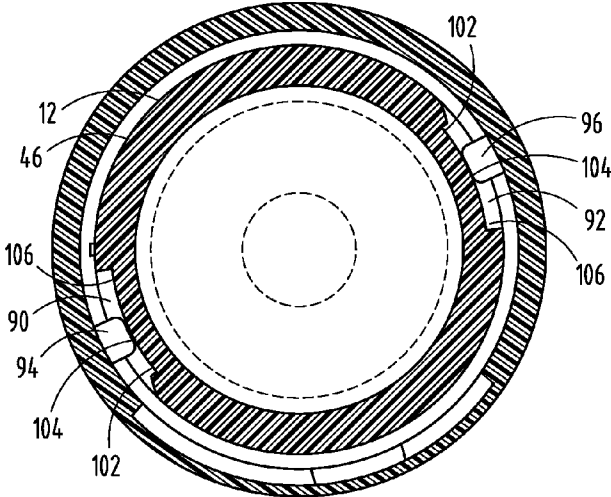

FIG. 21E

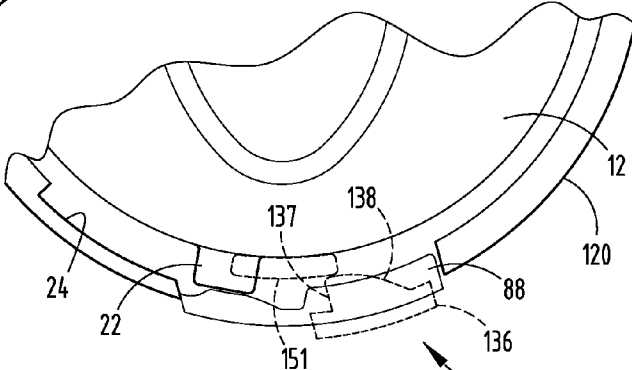

FIG. 21F

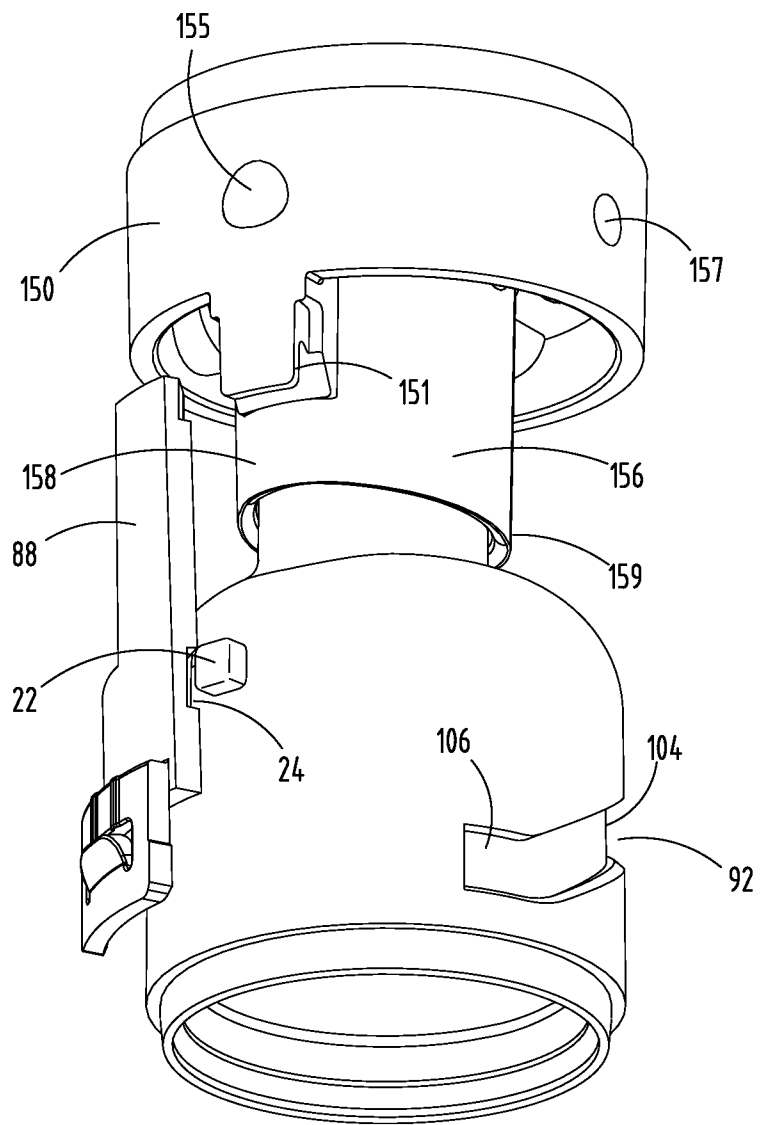

FIG. 22A

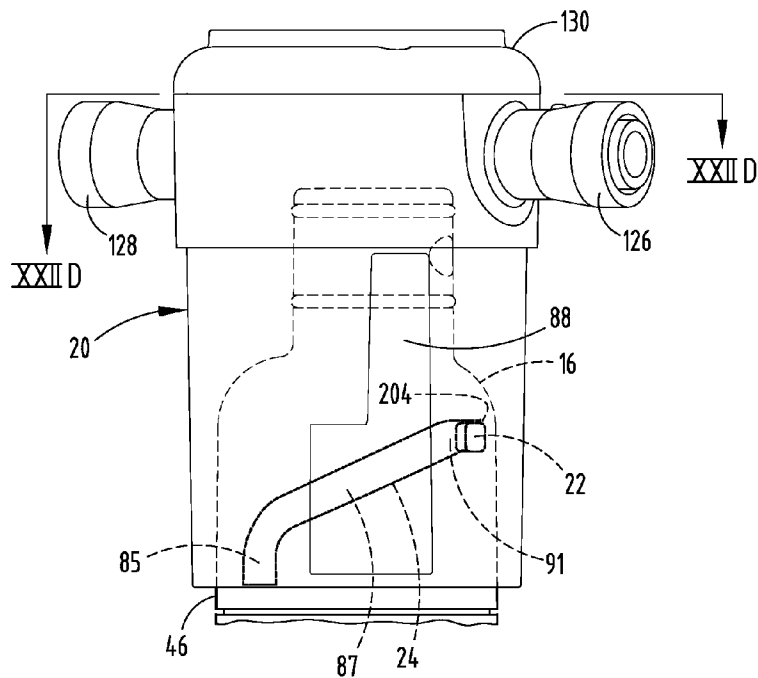

FIG. 22B

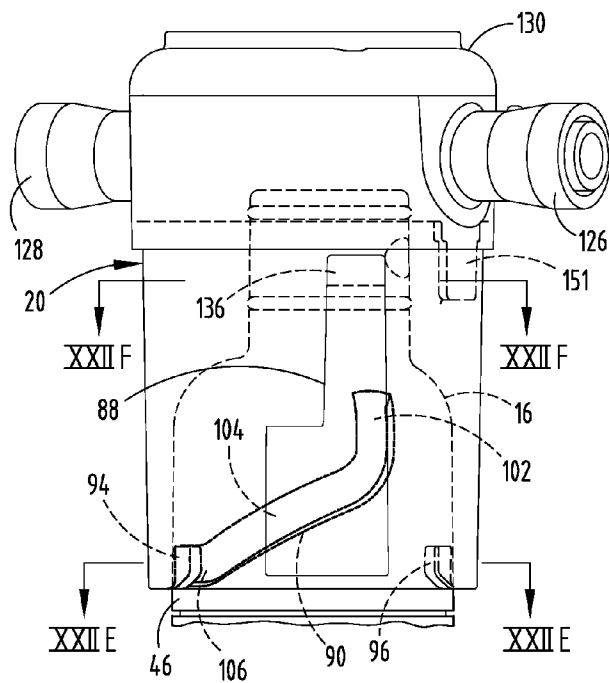

FIG. 22C

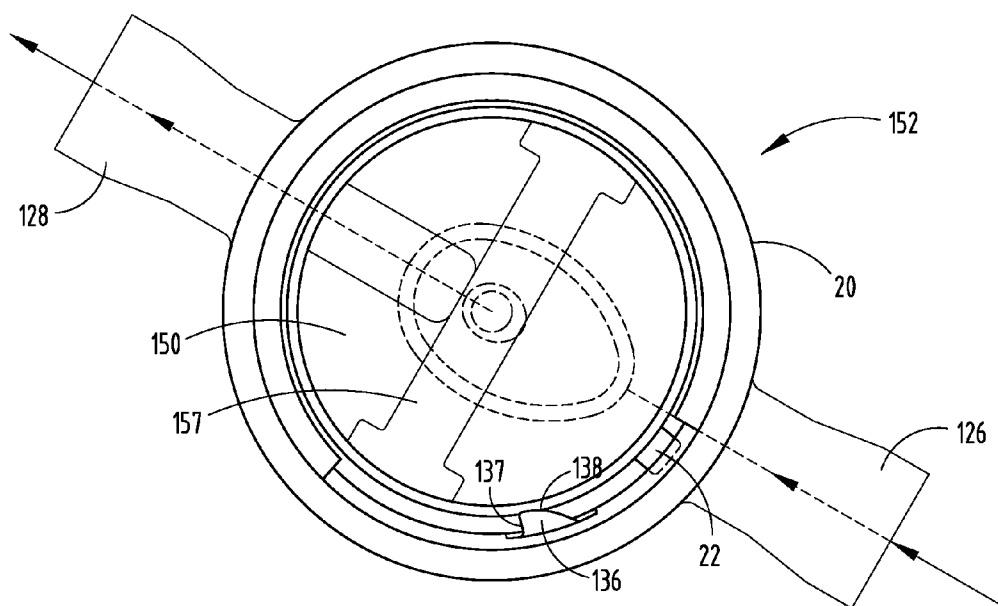

FIG. 22D

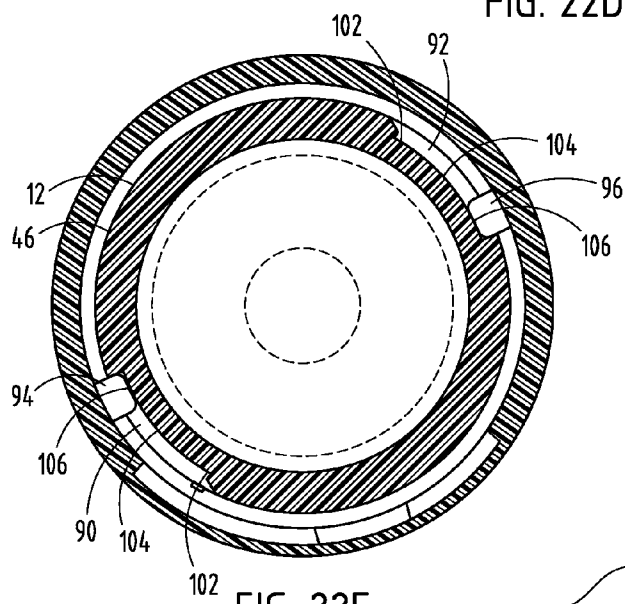

FIG. 22E

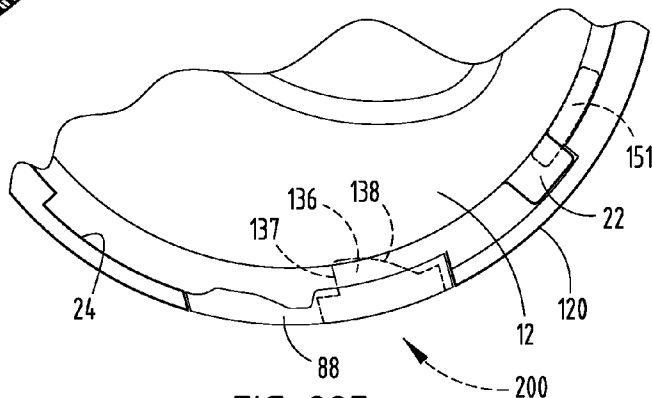

FIG. 22F

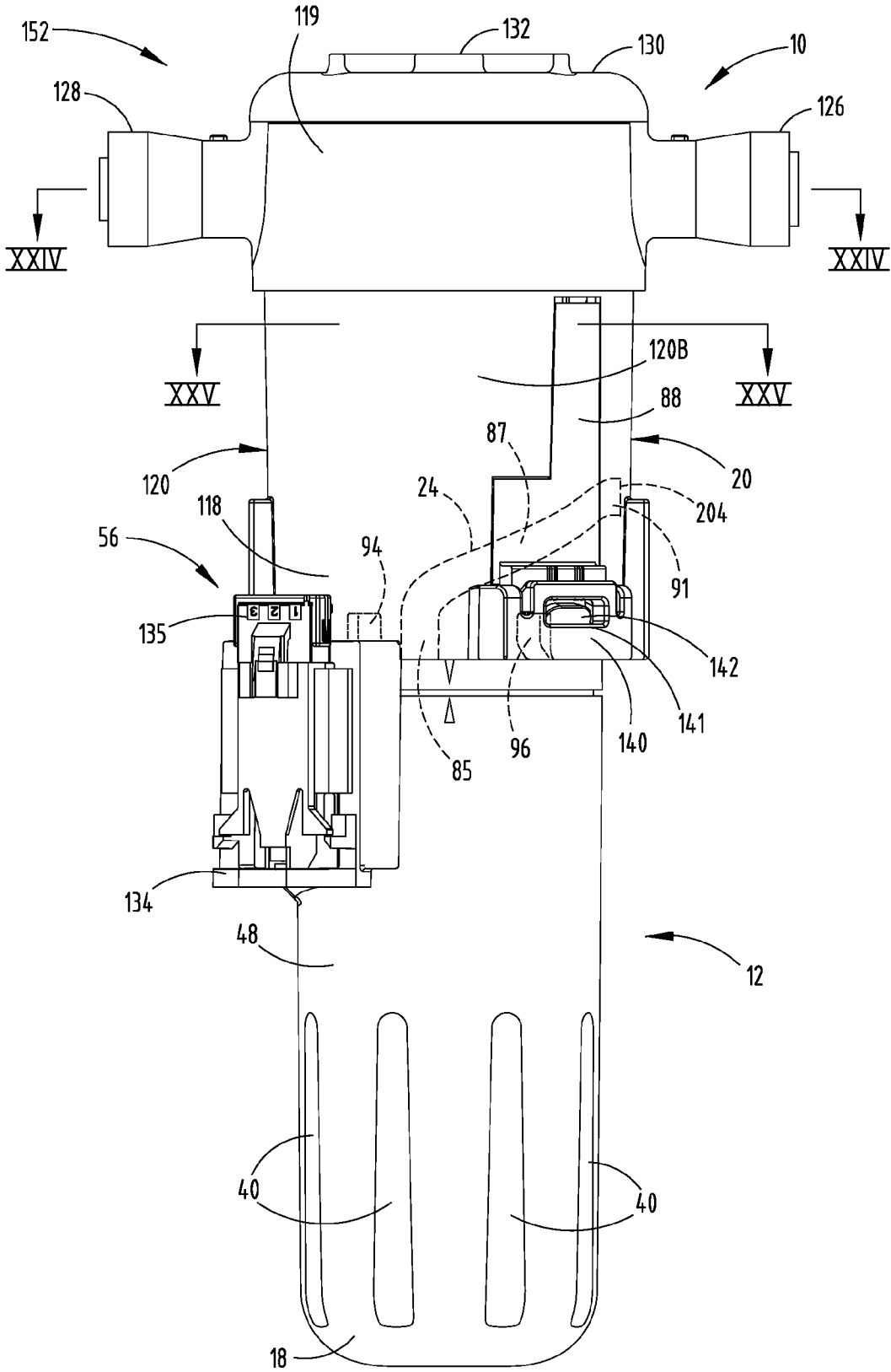

FIG. 23

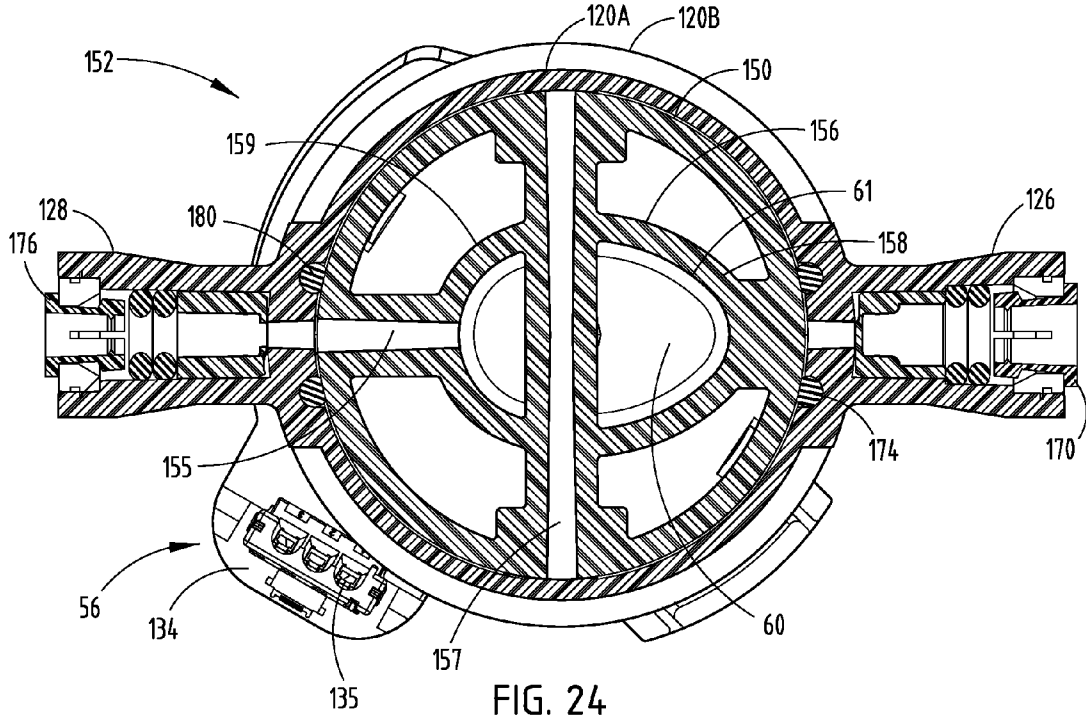

FIG. 24

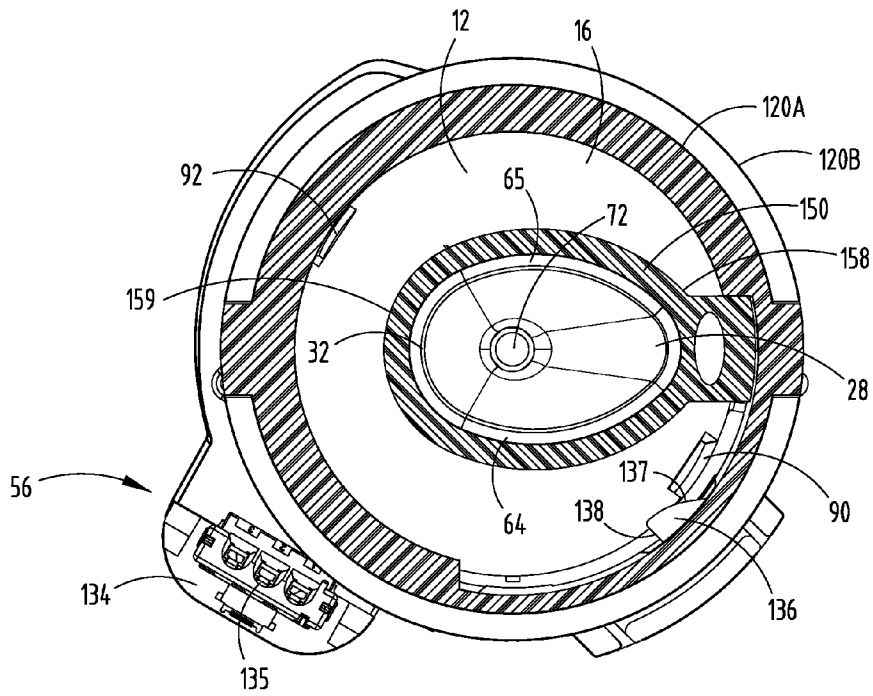

FIG. 25

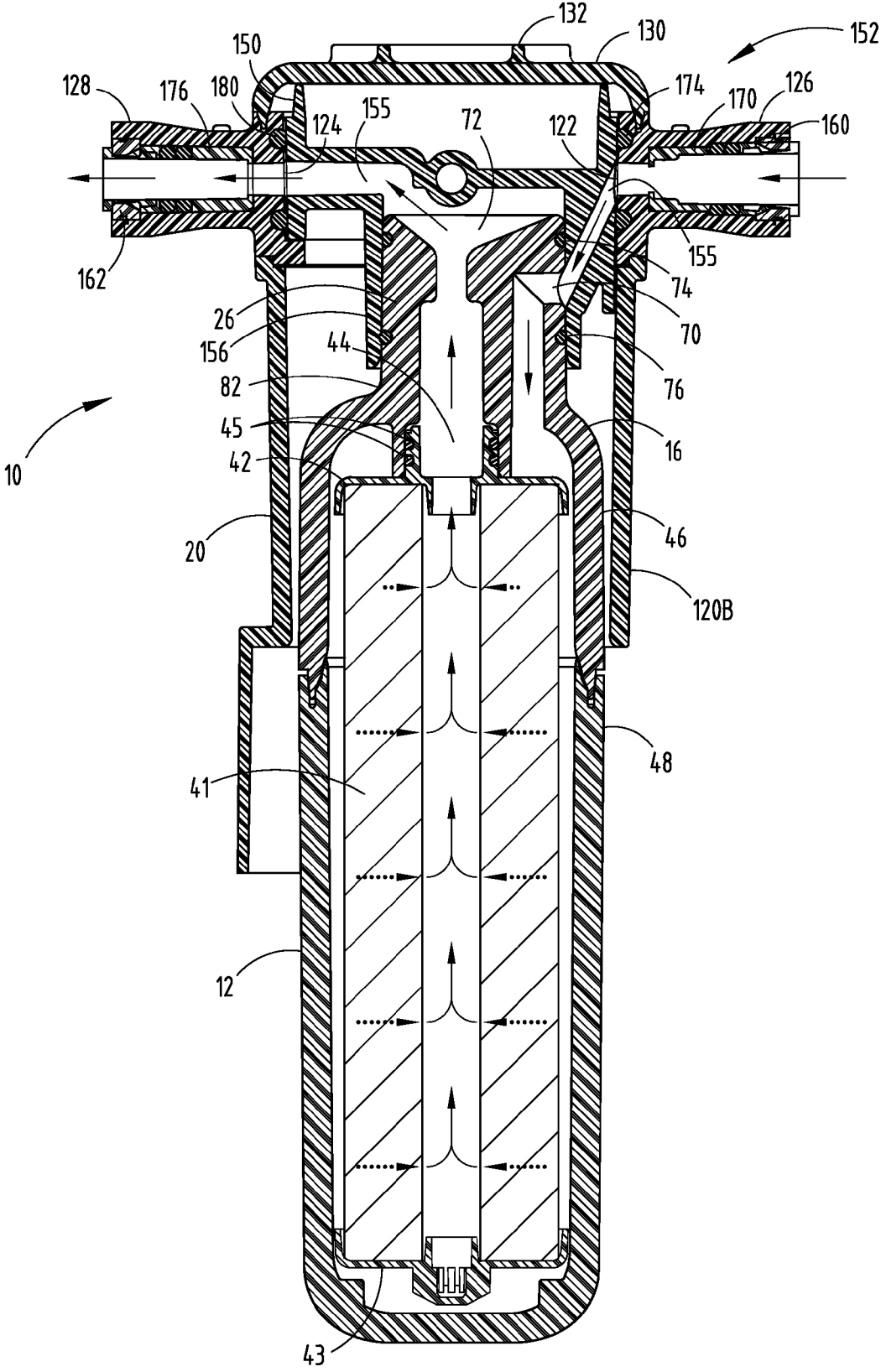

FIG. 26

ELECTRONIC INTERFACE FOR WATER FILTER

CROSS-REFERENCE TO RELATED APPLICATIONS

[0001] This application is a continuation of U.S. patent application Ser. No. 14/073,145, filed on Nov. 6, 2013, entitled "ELECTRONIC INTERFACE FOR WATER FILTRATION SYSTEM," which is a continuation of U.S. patent application Ser. No. 13/233,347, filed on Sep. 15, 2011, entitled "ELECTRONIC INTERFACE FOR WATER FILTRATION SYSTEM," now U.S. Pat. No. 8,580,109, the entire disclosures of which are hereby incorporated herein by reference.

BACKGROUND OF THE PRESENT INVENTION

[0002] The present invention generally relates to an electronic interface for a filter unit, and more specifically, to an electronic interface that allows for storage of data on the filter unit.

SUMMARY OF THE INVENTION

[0003] In one aspect of the present invention, a water filter includes a filter unit having a body portion adapted to be rotatably received into a filter head assembly. An engagement protrusion extends from the body portion and is adapted for reception in a complementary receiver in the filter head assembly. An electronic device is disposed on the filter unit having a memory storage unit. A laterally extending key member is disposed on the body portion between the first engagement surface and the second engagement surface. The laterally extending key member is adapted to reposition an interference member from an interference position, whereby the body portion can be fully inserted into the filter head assembly to a non-interference position, whereby the body portion can be fully inserted into the filter head assembly.

[0004] In another aspect of the present invention, a water filter includes a removable filter unit having a body portion including a proximal end and a distal end. The proximal end is adapted to be inserted into a filter head assembly. An electronic device is disposed on the filter unit and adapted to engage an electronic connector on the filter head assembly. An engagement protrusion extends from the proximal end. The engagement protrusion has a first portion that includes a first radius of curvature and a second portion opposing the first portion that includes a second radius of curvature that is larger than the first radius of curvature.

[0005] In yet another aspect of the present invention, a water filter includes a filter unit with an electronic device adapted for engagement with an electronic connector interface of a filter head assembly. An engagement protrusion extends from the body portion. The engagement protrusion has a cross-section with only one axis of symmetry. A side aperture is disposed on the engagement protrusion. An end aperture is disposed on the engagement protrusion.

[0006] These and other features, advantages, and objects of the present invention will be further understood and appreciated by those skilled in the art upon studying the following specification, claims, and appended drawings.

BRIEF DESCRIPTION OF THE DRAWINGS

[0007] FIG. 1 is a top perspective view of one embodiment of a water filter system of the present invention;

[0008] FIG. 2 is a front perspective view of the water filter system of FIG. 1 with the water filter withdrawn from the filter head assembly;

[0009] FIG. 3 is a top perspective view of one embodiment of a water filter of the present invention;

[0010] FIG. 3A is an enlarged cross-sectional view of the water filter of FIG. 3 taken at IIIA-III A;

[0011] FIG. 4 is an elevational view of a first side of the water filter of FIG. 3;

[0012] FIG. 4A is an enlarged elevational view of a first side of a forward casing of the water filter of FIG. 3;

[0013] FIG. 5 is a front elevational view of the water filter of FIG. 3 with casings;

[0014] FIG. 6 is an elevational view of a second side of the water filter of FIG. 3;

[0015] FIG. 6A is an enlarged elevational view of a second side of the forward casing of the water filter of FIG. 3;

[0016] FIG. 6B is an enlarged elevational view of a second side of another embodiment of a forward casing of the water filter of FIG. 3;

[0017] FIG. 7 is a rear elevational view of the water filter of FIG. 3;

[0018] FIG. 7A is an enlarged cross-sectional view of the water filter of FIG. 3 taken at VIIA-VII A;

[0019] FIG. 8 is a top exploded perspective view of the water filter of FIG. 3;

[0020] FIG. 9 is a top plan view of the water filter of FIG. 3;

[0021] FIG. 10 is a bottom plan view of the water filter of FIG. 3;

[0022] FIG. 11 is a top perspective view of one embodiment of a filter head assembly of the present invention;

[0023] FIG. 12 is a front elevational view of the filter head assembly of FIG. 11;

[0024] FIG. 13 is an elevational view of a first side of the filter head assembly of FIG. 11;

[0025] FIG. 14 is a rear elevational view of the filter head assembly of FIG. 11;

[0026] FIG. 15 is an elevational view of a second side of the filter head assembly of FIG. 11;

[0027] FIG. 16 is a bottom plan view of the filter head assembly of FIG. 11;

[0028] FIG. 17 is a top plan view of the filter head assembly of FIG. 11;

[0029] FIG. 17A is a top plan view of another embodiment of the filter head assembly of FIG. 11;

[0030] FIG. 18 is an exploded top perspective view of the filter head assembly of FIG. 11;

[0031] FIG. 19 is a bottom exploded perspective view of engaging components of the filter head assembly and filter unit;

[0032] FIG. 20A is an enlarged side perspective view of engaging components of the filter head assembly and filter unit prior to engagement;

[0033] FIG. 20B is a side elevational view of a filter unit prior to engagement with the filter head assembly illustrating the lateral engagement key member and key slot prior to engagement;

[0034] FIG. 20C is a side elevational view of the filter unit prior to engagement with the filter head assembly illustrating the first and second guides and the first and second engagement surfaces prior to engagement;

[0035] FIG. 20D is a cross-sectional view of the filter head assembly of FIG. 20B taken at XXD-XXD;

[0036] FIG. 20E is a cross-sectional view of the filter head assembly of FIG. 20C taken at XXE-XXE;

[0037] FIG. 20F is a partial cross-sectional view of the filter head assembly of FIG. 20C taken at XXF-XXF;

[0038] FIG. 20G is a side cross-sectional view of a filter unit prior to installation into a head assembly;

[0039] FIG. 21A is an enlarged side perspective view of engaging components of the filter head assembly and filter unit during engagement;

[0040] FIG. 21B is a side elevational view of a filter unit during engagement with the filter head assembly illustrating the lateral engagement key member and key slot engaging;

[0041] FIG. 21C is a side elevational view of the filter unit during engagement with the filter head assembly illustrating the first and second guides and engaging the first and second engagement surfaces engaging;

[0042] FIG. 21D is a cross-sectional view of the filter head assembly of FIG. 21B taken at XXID-XXID;

[0043] FIG. 21E is a cross-sectional view of the filter head assembly of FIG. 21C taken at XXIE-XXIE;

[0044] FIG. 21F is a partial cross-sectional view of the filter head assembly of FIG. 21C taken at XXIF-XXIF;

[0045] FIG. 22A is an enlarged side perspective view of engaging components of the filter head assembly and filter unit fully engaged;

[0046] FIG. 22B is a side elevational view of a filter unit in full engagement with the filter head assembly illustrating the lateral engagement key member and key slot fully engaged;

[0047] FIG. 22C is a side elevational view of the filter unit in full engagement with the filter head assembly illustrating the first and second guides and the first and second engagement surfaces fully engaged;

[0048] FIG. 22D is a cross-sectional view of the filter head assembly of FIG. 22B taken at XXIID-XXIID;

[0049] FIG. 22E is a cross-sectional view of the filter head assembly of FIG. 22C taken at XXIIE-XXIIE;

[0050] FIG. 22F is a partial cross-sectional view of the filter head assembly of FIG. 22C taken at XXIIF-XXIIF;

[0051] FIG. 23 is a front elevational view of the water filter system with the water filter fully installed into the filter head assembly;

[0052] FIG. 24 is an enlarged cross-sectional view of the water filter of FIG. 23 taken at XXIV-XXIV;

[0053] FIG. 25 is an enlarged cross-sectional view of the water filter of FIG. 17 taken at XXV-XXV; and

[0054] FIG. 26 is a side cross-sectional view of a filter unit fully installed into the filter head assembly.

DETAILED DESCRIPTION OF EMBODIMENTS

[0055] For purposes of description herein the terms “upper,” “lower,” “right,” “left,” “rear,” “front,” “vertical,” “horizontal,” and derivatives thereof shall relate to the invention as oriented in FIGS. 1 and 3. However, it is to be understood that the invention may assume various alternative orientations and step sequences, except where expressly specified to the contrary. It is also to be understood that the specific devices and processes illustrated in the attached drawings, and described in the following specification are simply exemplary embodiments of the inventive concepts defined in the appended claims. Hence, specific dimensions and other physical characteristics relating to the embodiments disclosed herein are not to be considered as limiting, unless the claims expressly state otherwise.

[0056] Referring to the embodiment illustrated in FIGS. 1 and 2, reference numeral 10 generally designates a water filter system including a filter unit 12 having a body portion 14 (FIG. 4) having a proximal end 16 and a distal end 18. The proximal end 16 is adapted to be inserted into a filter head assembly 20. A laterally extending key member 22 is disposed on the body portion 14 and adapted to engage a key slot 24 (FIG. 11) in the filter head assembly 20. An engagement protrusion 26 extends from the proximal end 16. The engagement protrusion 26 includes a first portion 28 having a first radius of curvature and a second portion 32 opposing the first portion 28 that includes a second radius of curvature that is larger than the first radius of curvature.

[0057] Referring now to FIGS. 3-4A, the body portion 14 of the filter unit 12 includes a cylinder-like construction having a diameter that is easily graspable by the hand of a user. A multitude of grasping cutouts 40 are disposed on the body portion 14 and extend toward the distal end 18 of the body portion 14 and are designed to provide a gripping surface for a user to both engage and disengage the filter unit 12 from the filter head assembly 20. As disclosed in further detail herein, engagement of the filter unit 12 typically includes rotational and longitudinal movement of the filter unit 12 relative to the filter head assembly 20. An internal portion of the filter unit 12 includes a water filter 39 having a filtering media 41 designed to filter and clean water that passes through the filter unit 12 during use. The filtering media 41 includes end caps 42, 43 that secure the filtering media 41 in place in the body portion 14 of the filter unit 12. The end cap 42 includes an outlet 44 that relays filtered water out of the filtering media 41 after the water has been filtered. Seals 45 prevent cross-contamination of unfiltered water with water that has gone through the filtering media 41 and been filtered.

[0058] As noted above, the first portion 28 of the engagement protrusion 26 has a first radius of curvature. The second portion 32 of the engagement protrusion 26 opposes the first portion 28 and has a second radius of curvature that is larger than the first radius of curvature. Thus, a cross-section of the engagement protrusion 26 taken perpendicular to the longitudinal extent of the filter unit 12 is generally egg-shaped. More specifically, the engagement protrusion 26 includes a cross-section with only one axis of symmetry. As readily observed in FIG. 5, the engagement protrusion 26 is centrally aligned as viewed from the front. However, as illustrated in FIG. 6, the engagement protrusion 26 is offset as viewed from the side. Thus, the engagement protrusion 26 is generally disposed in an offset position on the proximal end of the filter unit 12.

[0059] The body portion 14 of the filter unit 12 is defined by a forward casing 46 and a rearward casing 48 that are placed in abutting engagement over the water filter 39 disposed inside the filter unit 12. The forward casing 46 may be attached to the rearward casing 48 in any known manner, such as by heat staking, welding, or mechanical fastener attachment. Alternatively, it is contemplated that the body portion 14 could include one integral casing formed from a single part. The engagement protrusion 26 extends from the proximal end 16 of the filter unit 12 and is smaller in cross-sectional area than the body portion 14 of the filter unit 12. The body portion 14 tapers gradually from the proximal end 16 to the distal end 18.

[0060] The illustrated embodiment of FIGS. 3-7 depict an electronic device 50 that is disposed on and extends from an outer circumference of the body portion 14 between the

proximal end 16 and the distal end 18 of the filter unit 12. In the illustrated embodiments, the electronic device 50 includes a protective cover 51 having a triangular-type cross-section with an apex 52 of the triangular-type cross-section extending away from the body portion 14 of the filter unit 12. The electronic device 50 includes a power contact 54A, a data contact 54B, and a ground contact 54C. The data contact 54B relays information pertaining to the filter unit 12 capacity, filter unit 12 usage data, and the number of days until a replacement filter unit 12 is needed. The ground contact 54C provides a conducting path to a grounding source, which is independent of the normal current-carrying path of the electronic device 50.

[0061] The electronic device 50 is used in conjunction with a smart filter system 56 that includes a smart filter board 58 that stores payload information values related to timeout intervals based on hours, minutes, and seconds. These values are used to determine how long a user interface waits for communication from the smart filter system 56 before triggering a replace filter icon. In addition, sync user functionality is used to trigger a configuration of the smart filter system 56. Reconfiguration of the smart filter system 56 may be used to ensure that the application control unit, user interface, and smart filter are all using the same values. This information is all stored in the smart filter board 58 on the electronic device 50.

[0062] The electronic device 50 may use gold plating, or other conductive metals, on the contacts 54A, 54B, and 54C. The gold plating ensures a good connection with an extremely low ampere circuit in a potentially moist environment. Connector grease, or an equivalent, may be used to help isolate the contacts 54A, 54B, and 54C and avoid shorting of the contacts 54A, 54B, and 54C due to moisture. In addition, the protective cover 51 is implemented to protect the smart filter board 58 after installation into the filter head assembly 20. This protective cover 51 also protects the grease prior to being installed into the filter head assembly 20, and provides electrostatic discharge (ESD) protection. As a result of the isolated low voltage application in the smart filter system 56, the electronic device 50 is safe during the installation of the filter unit 12 into the filter head assembly 20.

[0063] Referring to FIGS. 3A and 7A, an engagement or end wall 60 of the engagement protrusion 26 is integral with a sidewall 61 of the engagement protrusion 26 and has a concave construction that tapers downwardly to an end aperture, which constitutes an outlet 72 of the filter unit 12. A side aperture, which constitutes an inlet 70, is positioned in the sidewall 61 of the engagement protrusion 26. For purposes of description, as viewed in FIGS. 3A and 7A, the filter unit 12 is described in an upright position, wherein the longitudinal axis of the filter unit 12 is in a substantially vertical orientation. In the illustrated embodiment, an angle α of the engagement wall 60 adjacent to the first portion 28 has an angle approximately 67.7 degrees from vertical. It is contemplated that the angle α could be as low as 15 degrees or as high as 90 degrees. An angle β of the engagement wall 60 of the engagement protrusion 26 at the second portion 32 of the engagement protrusion 26 is approximately 51 degrees, although it is contemplated that the angle β could be as low as 5 degrees or as high as 85 degrees. It will be noted that the degrees and constructions of the engagement wall 60 may vary from these specified angles and still be within the scope of the present invention. As shown in FIG. 7A, the angle θ of the engagement wall 60 in the engagement protrusion 26 is approxi-

mately 46.9 degrees from vertical on both third and fourth portions 64, 65 of the engagement protrusion 26. It is contemplated that the angle θ could be as low as 10 degrees or as high as 85 degrees. As illustrated, the first and second portions 28, 32 of the engagement protrusion 26 are not symmetrical, while the third and fourth portions 64, 65 of the engagement protrusion 26 are generally symmetrical.

[0064] Referring again to the embodiments of FIGS. 3A and 7A, the inlet 70 and the outlet 72 of the filter unit 12 have approximately the same diameter to dissipate extreme water pressure increases or decreases in the system. Nevertheless, it is contemplated that the diameter size of the inlet 70 and the outlet 72 could differ. Additionally, the engagement protrusion 26 includes first and second seals 74, 76, wherein the first seal 74 is disposed above the inlet 70 near a forward edge 78 of the engagement protrusion 26, and the second seal 76 is disposed between the inlet 70 and a base portion 82 of the engagement protrusion 26. Both the first and second seals 74, 76 extend around the sidewall 61 of the engagement protrusion 26. The first seal 74 keeps incoming unfiltered water entering the inlet 70 from cross-contaminating with exiting filtered water leaving the outlet 72. Therefore, the first seal 74 acts as a barrier, keeping the water to be filtered separate from the filtered water. The second seal 76 acts as a barrier that prevents filtered water from leaking around the body portion 14 during use.

[0065] Referring now to FIGS. 4 and 6-7, a shoulder 83 (FIG. 8) on the proximal end 16 of the filter unit 12 includes the laterally extending key member 22, which is adapted to interface with and disengage an interference member 88 (FIG. 1) disposed in the filter head assembly 20, as outlined in further detail herein. The laterally extending key member 22, as illustrated, includes a square shape. The laterally extending key member 22 may extend out from the body portion 14 approximately 0.5 to 10 mm. In the illustrated embodiment, the laterally extending key member 22 extends out from the body portion 14 approximately 2.75 mm. However, it is contemplated that the shape of the laterally extending key member 22 could also be circular, oval, polygonal, etc. The laterally extending key member 22 includes a profile height that is adapted to be received in a key slot 24 inside the filter head assembly 20. The key slot 24 includes three segments that define the key slot 24 shape. A first segment 85 (FIG. 11) is substantially linear and parallel with the longitudinal extent of the filter head assembly 20. A second segment 87 (FIG. 11) extends at an angle between 0 degrees and 98 degrees relative to the longitudinal extent of the filter head assembly 20. A third segment 91 (FIG. 11) extends substantially laterally or normal to the longitudinal extent of the filter head assembly 20. The third segment 91 may angle back 0 degrees to 25 degrees to provide a detent-type configuration that is adapted to secure the laterally extending key member 22 in place in the key slot 24 of the filter head assembly 20.

[0066] In an alternative embodiment, as illustrated in FIG. 6A, the engagement protrusion 26 includes a stepped construction including a ledge 93 adapted to interface with a complementary receiving ledge 95 (FIG. 17A) in the filter head assembly 20. This design ensures that the first and second seals 74, 76 disengage the filter head assembly 20 at the same time.

[0067] As shown generally in FIGS. 4-10, first and second engagement surfaces 90, 92 are disposed on the filter unit 12 on opposite sides thereof. The illustrated embodiment depicts the first and second engagement surfaces 90, 92 in the form of

channeled grooves. However, it is contemplated that the first and second engagement surfaces **90, 92** could be formed from externally protruding walls, or a combination of grooves and externally protruding walls, among other possible constructions. The first and second engagement surfaces **90, 92** are adapted to engage first and second guides **94, 96** (FIG. 11), respectively, juxtapositioned on an interior wall **99** (FIG. 17) that defines a receiving cavity **100** (FIG. 18) of the filter head assembly **20**. Similar to the laterally extending key member **22**, the first and second engagement surfaces **90, 92** are shown having a square shape. However, it is contemplated that the square shape of the first and second engagement surfaces **90, 92** could also be circular, oval, polygonal, etc. Similar to the key slot **24**, the first and second engagement surfaces **90, 92** include three segments. Specifically, each of the first and second engagement surfaces **90, 92** includes a first segment **102** that is substantially linear and parallel with the longitudinal extent of the body portion **14** of the filter unit **12**. A second segment **104** of the first and second engagement surfaces **90, 92** extends at an angle between 0 degrees and 90 degrees relative to the longitudinal extent of the body portion **14** of the filter unit **12**. In the illustrated embodiment, the angle A (FIG. 4A) of the second segment **104** of the first and second engagement surfaces **90, 92** is 62 degrees from vertical. A third segment **106** of the first and second engagement surfaces **90, 92** extends substantially laterally or normal to the longitudinal extent of the body portion **14** of the filter unit **12**. Alternatively, the third segment **106** may angle back 0 degrees to 25 degrees to provide a detent-type configuration that is adapted to secure the first and second guides **94, 96** in place after engagement of the filter unit **12** with the filter head assembly **20**. Each of the first, second, and third segments **102, 104, and 106** of the first and second engagement surfaces **90, 92** provide a smooth engagement of the filter unit **12** with the filter head assembly **20** during installation of the filter unit **12**, as discussed in further detail herein.

[0068] As shown in FIG. 9, the laterally extending key member **22** is not aligned with, but instead is generally offset from, the inlet **70** of the engagement protrusion **26**. The shoulder **83** of the filter unit **12** is generally rounded. However, the shoulder **83** could be angled or be squared off. As shown in FIG. 10, the distal end **18** of the filter unit **12** is also generally rounded, but could include other constructions. A substantially planar portion **108** (FIG. 7A) is disposed at the distal end **18** of the filter unit **12**, and allows the filter unit **12** to be placed in an upright position.

[0069] Referring now to FIGS. 11-16, the filter head assembly **20** includes a filter unit receiving end **118** and a water receiving end **119**. The filter head assembly **20** has a cylindrical receiver **120** that is defined by an interior wall portion **120A** (FIG. 17) and an exterior wall portion **120B**. The cylindrical receiver **120** is adapted to receive all or at least a portion of the proximal end **16** of the filter unit **12**. An external circumference of the interior wall portion **120A** includes an inlet port **122** (FIG. 18) and an outlet port **124** (FIG. 18) defined by opposing inlet and outlet extension members **126, 128**, respectively. The exterior wall portion **120B** includes wall slots **129** (FIG. 18) that are sized to generally accommodate the inlet and outlet extension members **126, 128**. Although the inlet and outlet extension members **126, 128** are shown on opposite sides of the filter head assembly **20**, it is contemplated that the inlet and outlet extension members **126, 128** could be at any angle relative to one another and disposed at any position on the external circumference of the

interior wall portion **120A**. The cylindrical receiver **120** includes an end wall **130** positioned on the cylindrical receiver **120** proximate the water receiving end **119**. Structural supports **132** (FIG. 16) are disposed on an external surface of the end wall **130**. An electronic connector extends from an edge of the cylindrical sidewall **132** of the filter head assembly **20** and is adapted for engagement with the electronic device **50** on the filter unit **12**. Additionally, a clip **134** is positioned on the exterior circumference of the filter head assembly **20** and is designed to support an electronic connector **135** on the filter head assembly **20**. The electronic connector **135** is designed to receive information from and communicate information to the electronic device **50**. The electronic connector **135** is removably connected with the clip **134**, such as by a snap-fit connection, with the clip **134**. Thus, the electronic connector **135** can be removed and replaced, if necessary.

[0070] Referring again to FIGS. 11-15, the key slot **24** is formed on an interior side of the exterior wall portion **120B**. The key slot **24**, as mentioned herein, is designed to receive the laterally extending key member **22** when the filter unit **12** is being inserted into the filter head assembly **20**. In addition, the interference member **88** forms a portion of the exterior wall portion **120B**, and is designed to prevent a filter unit that lacks a laterally extending key member from engaging the filter head assembly **20**. The interference member **88** includes an abutment catch **136** (FIG. 17) disposed at a distal end of the interference member **88** at an interior side of the interference member **88**. The abutment catch **136** includes an abutment wall **137** (FIG. 17) and a sloped wall **138**. The interference member **88** is connected to the exterior wall portion **120B** proximate the filter unit receiving end **118**. A portion of the key slot **24** extends along an interior side of the interference member **88**. As illustrated, the interference member **88** is connected with the exterior wall portion **120B** by a securing clip **140** (FIG. 18). The securing clip **140** includes an aperture **141** (FIG. 18) adapted to receive a clip protuberance **142** (FIG. 18) disposed on the interference member **88**. However, it is contemplated that the interference member **88** could be connected in other manners, such as by a living hinge, adhesive, mechanical fasteners, etc.

[0071] Turning now to FIGS. 17-19, the filter head assembly **20** also includes a filter receiver **150** with a stop member **151**. The filter receiver **150** is rotatable inside the filter head assembly **20** between a filtering position **152** (FIG. 22D) and a bypass position **154** (FIG. 20D), wherein unfiltered water passes through the filter head assembly **20** when the filter unit **12** is not installed. The filter head assembly **20** also includes a filter head sleeve **156** that includes a cross-section that complements the shape of the engagement protrusion **26**. Generally stated, the cross-section of the filter head sleeve **156** is egg-shaped. More specifically, the filter head sleeve **156** includes a first portion **158** that includes a first radius of curvature and a second portion **159** opposing the first portion **158** that includes a second radius of curvature that is larger than the first radius of curvature. Thus, the filter head sleeve **156** includes a cross-section with only one axis of symmetry. The filter head sleeve **156** is sized slightly larger than the engagement protrusion **26** such that the filter head sleeve **156** can closely receive and retain the engagement protrusion **26** and maintain a watertight seal with the aid of the first and second seals **74, 76**.

[0072] In an alternative embodiment, as illustrated in FIG. 17A, the filter head sleeve **156** may include the stepped con-

struction briefly mentioned above with reference to FIG. 6A, such that the filter head sleeve 156 includes the receiving ledge 95, which is adapted to engage and abut the ledge 93 on the engagement protrusion 26. During insertion, the stepped construction of both the filter head sleeve 156 and the engagement protrusion 26 allows the first and second seals 74, 76 to engage the filter head sleeve 156 simultaneously. Similarly, during removal, the stepped construction allows the first and second seals 74, 76 to disengage the filter head sleeve 156 simultaneously.

[0073] Referring again to FIGS. 17-19, the filter receiver 150 includes a filtering pathway 155 and a bypass channel 157. The bypass channel 157 allows water to flow through the filter head assembly 20 without being filtered. The filter head sleeve 156 of the filter receiver 150 is disposed inside the filter head assembly 20. The inlet and outlet extension members 126, 128 include couplings 160, 162 adapted to interface with an inlet water conduit 172 and an outlet water conduit 178, respectively. The coupling 160 includes an insert 170 that connects with the inlet extension member 126. The insert 170 is sealed by a gasket 174. The coupling 162 includes an insert 176 that connects with the outlet extension member 128. The insert 176 is sealed by a gasket 180. The gaskets 174, 180 of the inlet and outlet extension members 126, 128, respectively, keep water from leaking out of the inlet and outlet extension members 126, 128.

[0074] Referring to FIGS. 19 and 20A, during installation of the filter unit 12 with the filter head assembly 20, the filter unit 12 is oriented such that the engagement protrusion 26 is aligned with the filter receiver 150 and specifically aligned with the filter head sleeve 156, which includes an egg-shaped cross-section that complements the egg-shaped cross-section of the engagement protrusion 26, as outlined herein. Alignment of the engagement protrusion 26 with the filter head sleeve 156 results in alignment of the laterally extending key member 22 with the key slot 24, as well as alignment of the first and second guides 94, 96 with the first and second engagement surfaces 90, 92, as shown in FIGS. 20B, 20C, and 20E. In this position, the abutment catch 136 on the interference member 88 is in an interference position 200, as shown in FIGS. 20D and 20F. In addition, the engagement protrusion 26 is in only slight engagement with the filter head sleeve 156 of the filter receiver 150, as shown in FIG. 20G.

[0075] Referring now to FIGS. 21A-21C, linear movement of the filter unit 12 into the filter head assembly 20 generally occurs until the laterally extending key member 22 begins to transition from the first segment 85 into the second segment 87 of the key slot 24. At the same time, the first and second guides 94, 96 are transitioning from the first segment 102 of the first and second engagement surfaces 90, 92, respectively, into the second segment 104 of the first and second engagement surfaces 90, 92, respectively. As the laterally extending key member 22 transitions into the second segment 87 and the first and second guide members 94, 96 transition into the second segment 104 of the first and second engagement surfaces 90, 92, the filter unit 12 begins to rotate clockwise into the filter head assembly 20. Because the second segment 87 of the key slot 24 is at an angle relative to the longitudinal extent of the filter head assembly 20, and also because the second segment 104 of the first and second engagement surfaces 90, 92 is at the same general angle as the second segment 87 of the key slot 24, the filter unit 12 begins to draw into the filter head assembly 20, as shown in FIGS. 21B and 21C. At the same time, the engagement protrusion 26 has engaged and is par-

tially inserted into the filter head sleeve 156. Because the filter unit 12 is rotating into the filter head assembly 20, the engagement protrusion 26 subsequently rotates the filter head sleeve 156 and the filter receiver 150 as the filter unit 12 is drawn into the filter head assembly 20 (FIGS. 21D and 21E).

[0076] As shown in FIGS. 21A, 21B, and 21F, as the laterally extending key member 22 passes through the second segment 87 of the key slot 24, the laterally extending key member 22 passes by the interference member 88. As the laterally extending key member 22 passes by the interference member 88, the laterally extending key member 22 abuts the interference member 88 and forces the interference member 88 outward, thereby moving the abutment wall 137 on the abutment catch 136 from the interference position 200 to a non-interference position 202. When the interference member 88, and consequently the abutment wall 137 on the abutment catch 136, is moved to the non-interference position 202, the stop member 151 disposed on the filter receiver 150 is free to rotate past the interference member 88, and consequently the abutment catch 136. Absent the laterally extending key member 22, which abuts the interference member 88 and forces it outward, the abutment wall 137 on the abutment catch 136 would remain in the interference position 200, thereby preventing the stop member 151 on the filter receiver 150 from rotating past the interference member 88. Consequently, the filter unit 12 would be unable to move from the bypass position 154 (FIGS. 20A-20G) to the filtering position 152 (FIGS. 22A-22G).

[0077] Referring now to FIGS. 22A-22D, after the stop member 151 has cleared the abutment catch 136 on the interference member 88, the laterally extending key member 22 moves past the interference member 88 and begins to transition into the third segment 91 of the key slot 24. At the same time, the first and second guides 94, 96 transition into the third segment 106 of the first and second engagement surfaces 90, 92. As the key slot 24 engages a stop wall 204 in the key slot 24, the first and second guides 94, 96 engage the stop wall 204 (FIGS. 22E and 22F) in the third segment 106 of the first and second engagement surfaces 90, 92.

[0078] As shown in FIGS. 23-26, the filter unit 12 is now fully inserted into the filter head assembly 20 and the bypass channel 157 has been fully rotated out of alignment with the inlet extension member 126 and the outlet extension member 128. Consequently, water that flows into the filtering pathway 155 flows into the filter unit 12 through the inlet 70 through the sidewall 61 and into the water filter 39. The water then passes through the filtering media 41 and into a central column of the filter unit 12, where the water flows past the outlet 44 of the water filter 39 into the outlet 72 of the filter unit 12. The filtered water then passes into the filtered water pathway 155 of the filter receiver 150 and exits out the outlet extension member 128 to a water line. The water line then relays the filtered water to a dispenser, where it is available for consumption by a user.

[0079] When the filter unit 12 is to be replaced, the filter unit 12 is rotated counterclockwise and the reverse steps disclosed above are conducted. Notably, the laterally extending key member 22 does not move the interference member 88 out of the interference position 200 for the stop member 151 during removal. This step is unnecessary as the stop member 151 engages the sloped wall 138 of the abutment catch 136. Consequently, as a result of the sloped wall 138 construction, the stop member 151 is able to force the interference member 88 to the non-interference position 202 with-

out the assistance of the laterally extending key member 22. The filter unit 12 is then rotated counterclockwise until the filter unit 12 can be withdrawn in a linear motion from the filter head assembly 20.

[0080] In the illustrated embodiment, the water filter system 10 is adapted to receive a filter unit 12, which is fully inserted by a quarter turn installation. It is contemplated that the lengths of the segments of the first and second engagement surfaces 90, 92, as well as the lengths of the first, second, and third segments 85, 87, and 91 of the key slot 24 may vary such that the turning radius may be greater than or less than one quarter turn of the filter unit 12 relative to the filter head assembly 20.

[0081] It will be understood by one having ordinary skill in the art that the water filter system 10, as described herein, can be used in a variety of appliances, such as refrigerators, dishwashers, and clothes washers and dryers. Further, it will be understood that the water filter system 10 can be used for a variety of applications, such as a second stage water filter for a dishwasher, a water steam filter for an oven, and a water cleaning filter for consumption by a user out of a refrigerator. These are examples only and are not meant to be limiting.

[0082] The above description is considered that of the illustrated embodiments only. Modifications of the invention will occur to those skilled in the art and to those who make or use the invention. Therefore, it is understood that the embodiments shown in the drawings and described above is merely for illustrative purposes and not intended to limit the scope of the invention, which is defined by the following claims as interpreted according to the principles of patent law, including the Doctrine of Equivalents.

The invention claimed is:

1. A fluid filter comprising:
 - a body portion adapted to be received into a filter head assembly of an appliance, wherein receipt of the body portion in the filter head assembly triggers a reconfiguration of a filter system of the appliance;
 - an engagement protrusion extending from the body portion and adapted for reception in a complementary receiver in the filter head assembly;
 - an electronic device disposed on the filter having a memory storage unit, wherein the memory storage unit stores at least filter life data to define current filter life data; and
 - a data relay disposed within the electronic device, wherein triggering of the reconfiguration of the filter system is defined by the data relay delivering the current filter life data to the appliance.
2. The fluid filter of claim 1, wherein delivery of the current filter life data is via a wired connection with the filter head assembly.
3. The fluid filter of claim 1, wherein the reconfiguration of the filter system is further defined by a control unit and a user interface of the appliance utilizing the current filter life data delivered from the data relay of the electronic device.
4. The fluid filter of claim 1, where the current filter life data includes fluid flow values, and wherein when the current filter life data indicates that a predetermined fluid flow value is reached, the electronic device activates a replace filter icon of the user interface.
5. The fluid filter of claim 1, wherein the current filter life data includes filter life data gathered during operation of the electronic device in connection with a single appliance.
6. The fluid filter of claim 1, wherein the electronic device includes a circuit board positioned within a protective cover

that extends from the body portion, the circuit board adapted to store the current filter life data.

7. The fluid filter of claim 6, wherein the circuit board is in communication with a data portion of the electronic device, the data portion adapted to relay at least the current filter life data between the circuit board and the appliance.

8. The fluid filter of claim 1, wherein the body portion is rotatably received in the filter head assembly.

9. A method for installing a fluid filter into a subject appliance, the method comprising steps of:

providing a fluid filter configured for installation in an appliance, the fluid filter including a body portion adapted to be received into a filter head assembly of the appliance, an engagement protrusion extending from the body portion and adapted for reception in a complementary receiver in the filter head assembly and an electronic device disposed on the fluid filter having a memory storage unit and a data relay;

installing the fluid filter within the filter head assembly of the appliance;

triggering a reconfiguration of a filter system of the appliance by installing the fluid filter within the filter head assembly of the appliance;

storing at least filter life data pertaining to the fluid filter within the memory storage unit, wherein stored filter life data is continually updated during use of the fluid filter to define current filter life data; and

delivering the current filter life data to the appliance, wherein triggering of the reconfiguration of the filter system initiates delivery of the current filter life data to the appliance via the data relay of the electronic device.

10. The method of claim 9, wherein the step of installing the fluid filter is at least partially defined by the body portion being rotatably received in the filter head assembly.

11. The method of claim 9, wherein the step of delivering the current filter life data is performed via a wired connection between the memory storage unit and the filter head assembly.

12. The method of claim 9, wherein the step of delivering the current filter life data is performed via a one way communication link from the memory storage unit to the filter head assembly.

13. The method of claim 9, wherein the step of delivering the current filter life data to the appliance includes at least one of a control unit and user interface of the appliance utilizing the current filter life data delivered from the data relay of the electronic device.

14. The method of claim 13, where the current filter life data includes at least fluid flow values, and wherein when the current filter life data indicates that a predetermined fluid flow value is reached, the electronic device activates a replace filter icon of the user interface.

15. The method of claim 9, wherein the current filter life data includes filter life data gathered during operation of the electronic device in connection with a single appliance.

16. The method of claim 9, wherein the electronic device includes a circuit board positioned within a protective cover that extends from the body portion, the circuit board adapted to store the current filter life data.

17. The method of claim 16, wherein the circuit board is in communication with a data portion of the electronic device, the data portion adapted to relay at least the current filter life data between the circuit board and the appliance.

18. The method of claim **9**, wherein the current filter life data comprises:

payload information values related to timeout intervals of the fluid filter;
fluid filter capacity;
fluid filter usage date; and
a number of days until a replacement fluid filter unit is needed.

19. A fluid filter comprising:

a body portion adapted to be received into a filter head assembly of a subject appliance of a plurality of appliances, wherein receipt of the body portion in the filter head assembly triggers a reconfiguration of a filter system of the subject appliance;
an engagement protrusion extending from the body portion and adapted for reception in a complementary receiver in the filter head assembly of the subject appliance;
an electronic device disposed on the filter having a memory storage unit, wherein the memory storage unit stores at least filter life data to define current filter life data; and
a data relay disposed within the electronic device, wherein triggering of the reconfiguration of the filter system is defined by the data relay delivering the current filter life data to the appliance, wherein the electronic device includes a protective cover having a generally triangular-type cross section extending away from the body portion of the fluid filter.

20. The fluid filter of claim **19**, wherein delivery of the current filter life data is via a wired connection with the filter head assembly.

* * * * *