



US00D865167S

(12) **United States Design Patent**
Kirgizov et al.

(10) **Patent No.:** **US D865,167 S**

(45) **Date of Patent:** **** Oct. 29, 2019**

- (54) **DIGITAL STETHOSCOPE**
- (71) Applicant: **Bat Call D. Adler Ltd.**, Neshar (IL)
- (72) Inventors: **Dmitry Kirgizov**, Ramat Gan (IL);
Roece Haimovich, Migdal Ha'emek (IL)
- (73) Assignee: **Bat Call D. Adler Ltd.**, Neshar (IL)
- (**) Term: **15 Years**
- (21) Appl. No.: **29/630,202**
- (22) Filed: **Dec. 20, 2017**
- (51) **LOC (12) Cl.** **24-02**
- (52) **U.S. Cl.**
USPC **D24/134**
- (58) **Field of Classification Search**
USPC D24/134, 133, 135, 136, 140, 189
CPC A61B 7/04; A61B 17/17; A61B 17/16;
A61B 17/11; A61B 17/00; A61B 18/00;
A61B 19/00; A61B 17/1675; A61B
17/1764; A61B 17/1767; A61B 7/02;
A61F 2/46; A61F 2/4601; A61F 2/4603;
A61F 2/461; A61F 2/3868; A61F
2002/4631
See application file for complete search history.

D583,940 S * 12/2008 Wong D24/134
7,458,939 B2 12/2008 Munk
D621,504 S * 8/2010 Martinez D24/134
(Continued)

FOREIGN PATENT DOCUMENTS

CN 103479385 A 1/2014
CN 103479386 A 1/2014
(Continued)

OTHER PUBLICATIONS

Amazon. Link: <https://www.amazon.com/Thinklabs-One-Digital-Stethoscope/dp/B07BRQRNW7>. Jan. 6, 2019. Thinklabs One Digital Stethoscope. (Year: 2019).*
(Continued)

Primary Examiner — Susan Moon Lee
Assistant Examiner — Lauren D McVey
(74) *Attorney, Agent, or Firm* — Kligler & Associates

(57) **CLAIM**

The ornamental design for a digital stethoscope, as shown and described.

DESCRIPTION

FIG. 1 is a bottom, left-side perspective view of a digital stethoscope showing our new design; FIG. 2 is a top, right-side perspective view thereof; FIG. 3 is a top plan view thereof; FIG. 4 is a bottom plan view thereof; FIG. 5 is a front elevation view thereof; FIG. 6 is a rear elevation view thereof; FIG. 7 is a right side elevation view thereof; and, FIG. 8 is a left side elevation view thereof. The broken lines immediately adjacent to the shaded areas depict the bounds of the claimed design, while all other broken lines are directed to environment. The broken lines form no part of the claimed design.

1 Claim, 6 Drawing Sheets

(56) **References Cited**

U.S. PATENT DOCUMENTS

- 872,448 A * 12/1907 Penhallow A61B 7/02
181/131
- 3,433,959 A 3/1969 Atwood et al.
- 3,580,082 A 5/1971 Strack et al.
- D353,196 S * 12/1994 Savage D24/134
- 5,853,005 A 12/1998 Scanlon
- 6,154,551 A 11/2000 Frenkel
- D462,442 S * 9/2002 Webb D24/133
- 6,520,924 B2 2/2003 Lee
- D483,488 S * 12/2003 Luthy D24/140
- 6,699,204 B1 3/2004 Kehyayan et al.
- 6,788,417 B1 9/2004 Zumberge et al.
- D525,360 S * 7/2006 Nakamura D24/134

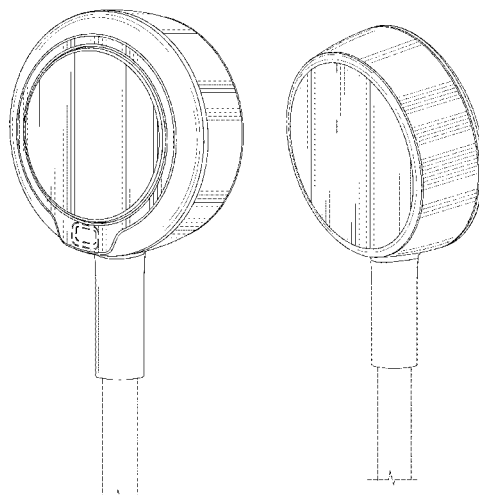

(56)

References Cited

U.S. PATENT DOCUMENTS

7,976,480 B2 7/2011 Grajales et al.
 8,015,878 B2 9/2011 Melikechi et al.
 8,419,652 B2 4/2013 Rajamani et al.
 8,475,396 B2 7/2013 Jones et al.
 D709,204 S * 7/2014 Kovach D24/187
 8,920,343 B2 12/2014 Sabatino
 9,101,274 B2* 8/2015 Bakema B06B 1/06
 D750,679 S * 3/2016 Habraken D16/135
 9,277,330 B2 3/2016 Aharoni et al.
 9,445,779 B2 9/2016 Shams et al.
 D821,576 S * 6/2018 Alatraste D24/134
 D837,979 S * 1/2019 Shan D24/134
 2001/0030077 A1 10/2001 Watson
 2002/0071570 A1 6/2002 Cohen et al.
 2005/0222515 A1 10/2005 Polyshchuk et al.
 2007/0050715 A1 3/2007 Behar
 2008/0013747 A1 1/2008 Tran
 2011/0137209 A1 6/2011 Lahiji et al.
 2011/0222697 A1 9/2011 Dong et al.
 2011/0224988 A1 9/2011 Mahajan et al.
 2013/0041278 A1 2/2013 Bai et al.
 2014/0073864 A1 3/2014 Engelbrecht et al.
 2014/0290372 A1 10/2014 Lagaros et al.
 2015/0073306 A1 3/2015 Abeyratne et al.
 2015/0119758 A1 4/2015 Rogers et al.
 2017/0079612 A1* 3/2017 Park A61B 7/04

FOREIGN PATENT DOCUMENTS

CN 203506748 U 4/2014
 CN 304170284 * 6/2017
 CN 304250517 * 8/2017

CN 304318235 * 10/2017
 CN 107510473 A 12/2017
 DE 202005006661 U1 8/2005
 KR 20120040530 A 4/2012
 WO 9325874 A1 12/1993
 WO 2002009586 A2 2/2002
 WO 2006075263 A1 7/2006
 WO 2011117862 A2 9/2011
 WO 2017141165 A1 8/2017

OTHER PUBLICATIONS

Bat-Call. Link: <https://bat-call.com/products/compusteth/>. Visited Mar. 23, 2019, Bat Call's CompuSteth. (Year: 2019).*

Padmanabhan et al., "Accelerometer type cardiac transducer for detection of low-level heart sounds", IEEE Transactions on Bio-medical Engineering, vol. 40, No. 1, pp. 21-28, Jan. 1, 1993.

International Application # PCT/IB2017/050833 search report dated Jul. 23, 2017.

International Application # PCT/IB2018/056335 search report dated Dec. 26, 2018.

International Application # PCT/IB2018/056336 search report dated Dec. 25, 2018.

Bukhman et al., "Spectral analysis of acoustic vibrations on the surface of the human body," Acoustical Physics, vol. 41, Issue 1, 10 pages, 1995.

* cited by examiner

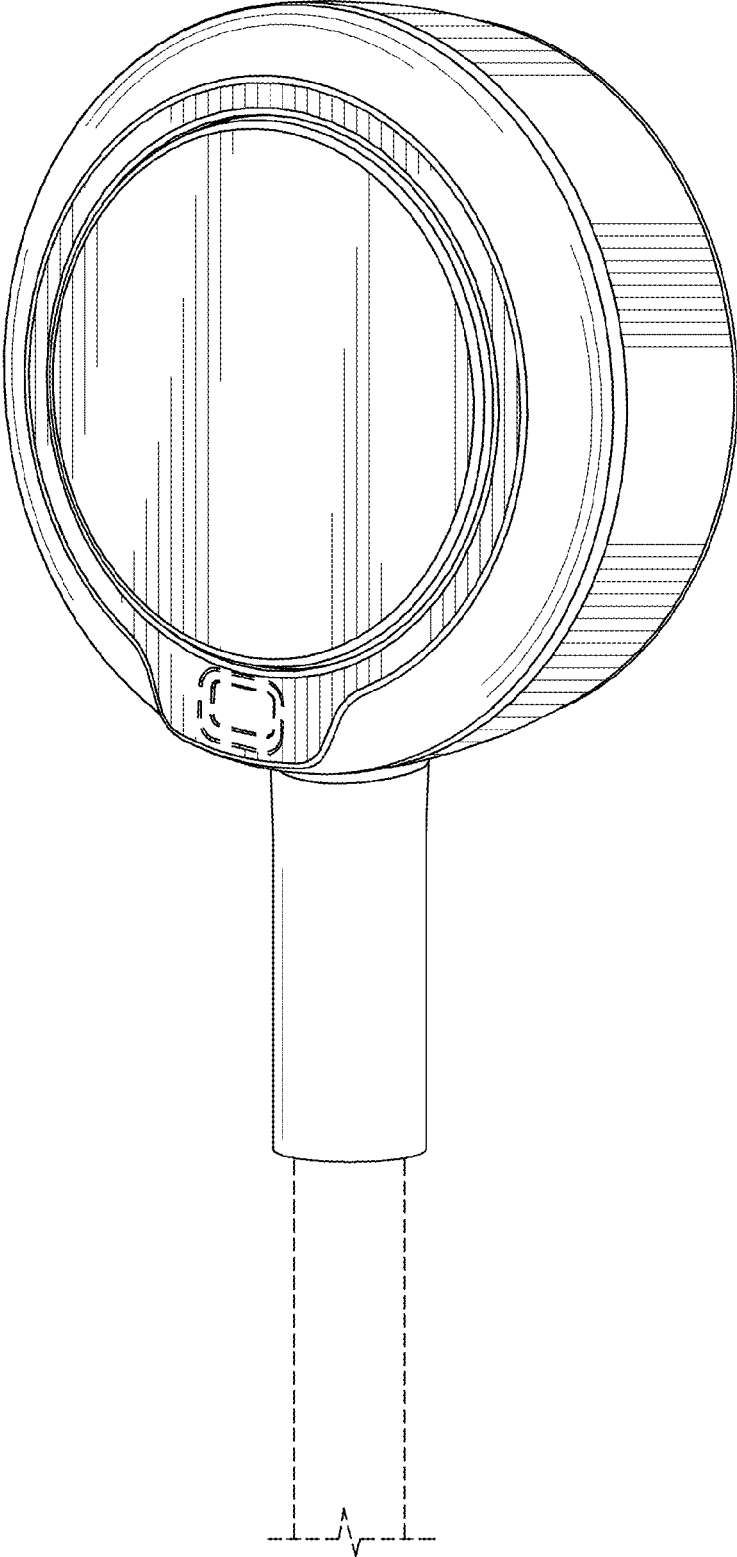

FIG. 1

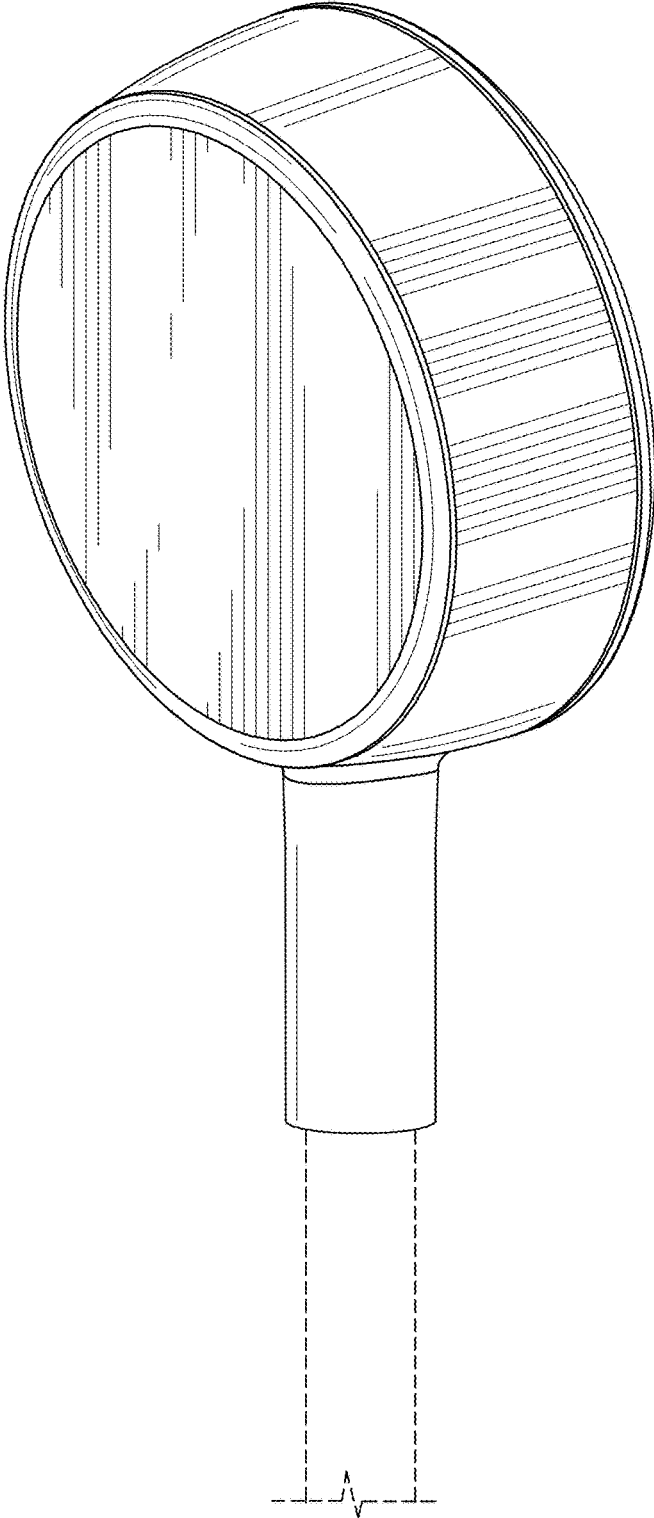

FIG. 2

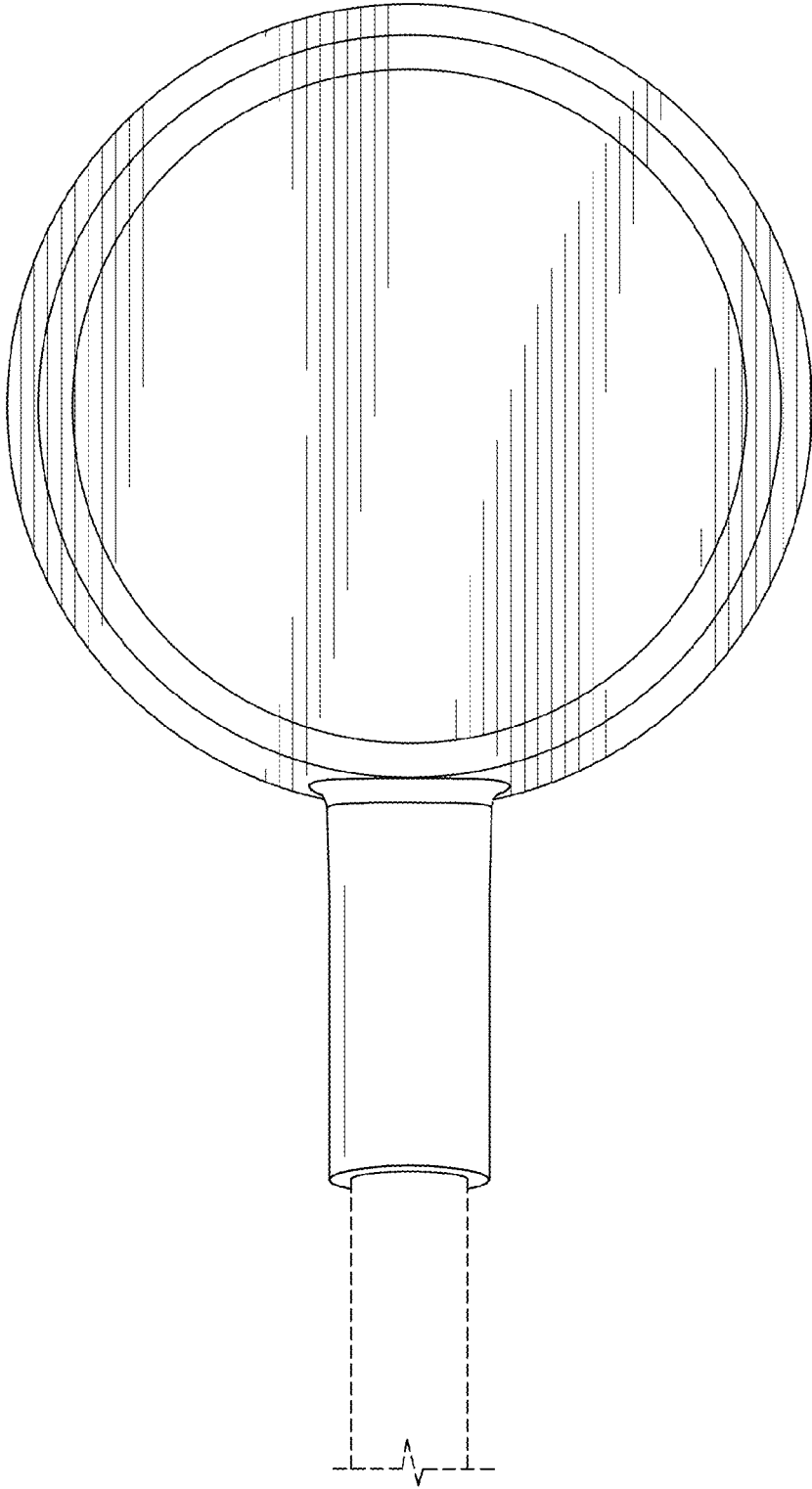

FIG. 3

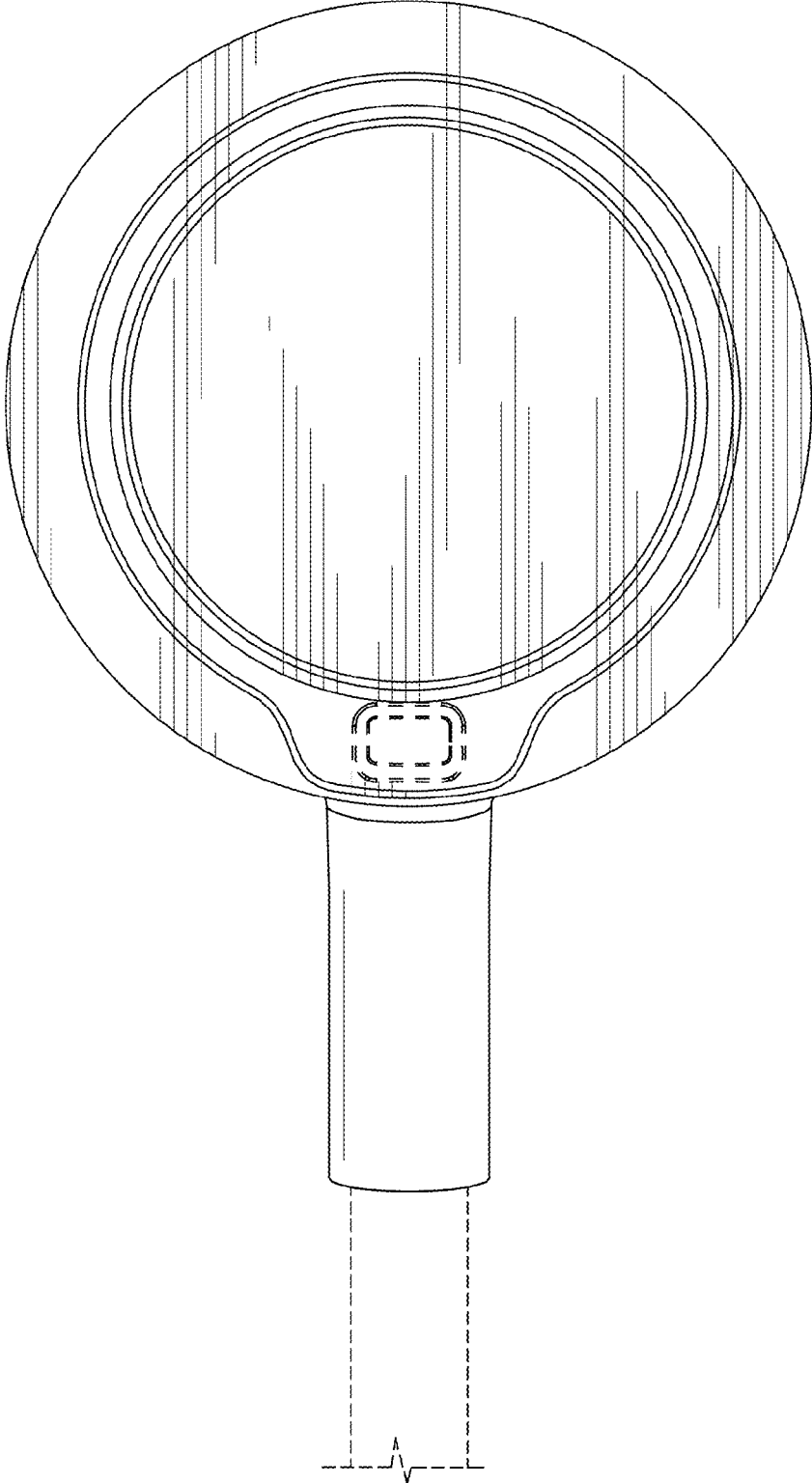

FIG. 4

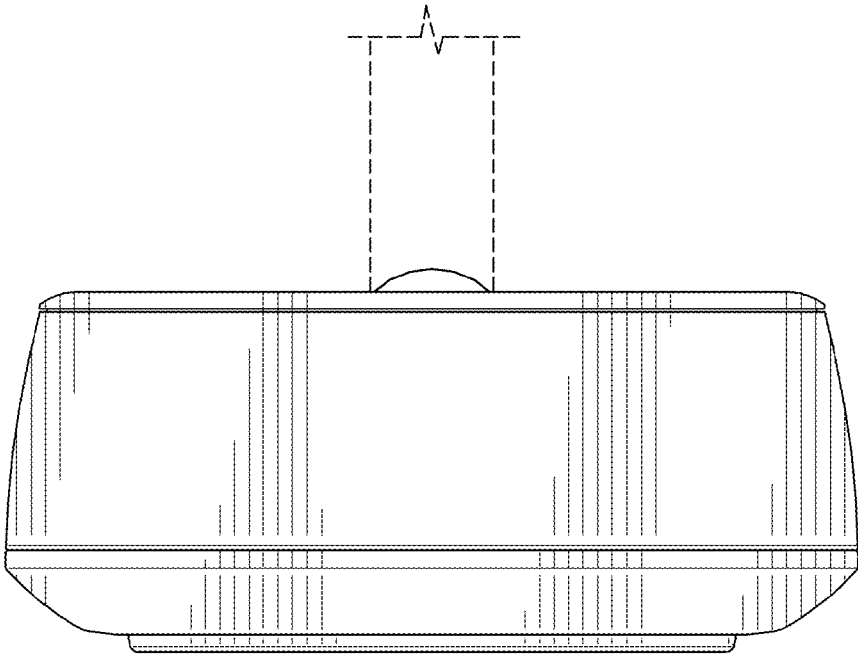

FIG. 5

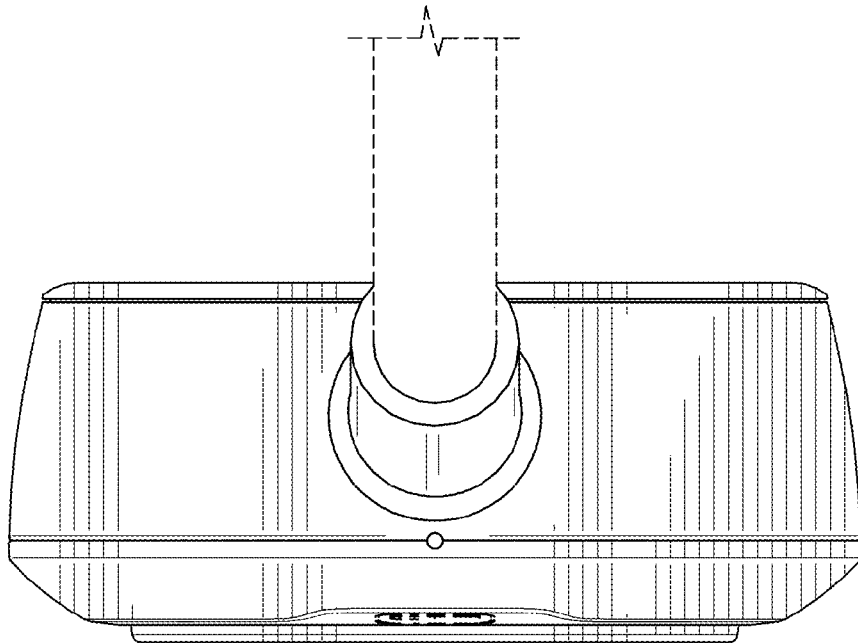

FIG. 6

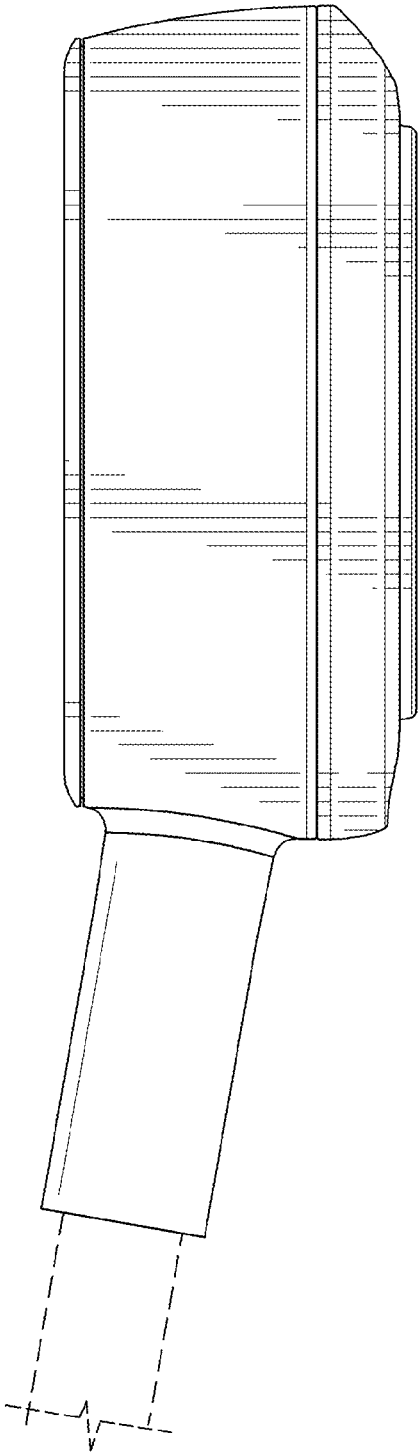

FIG. 7

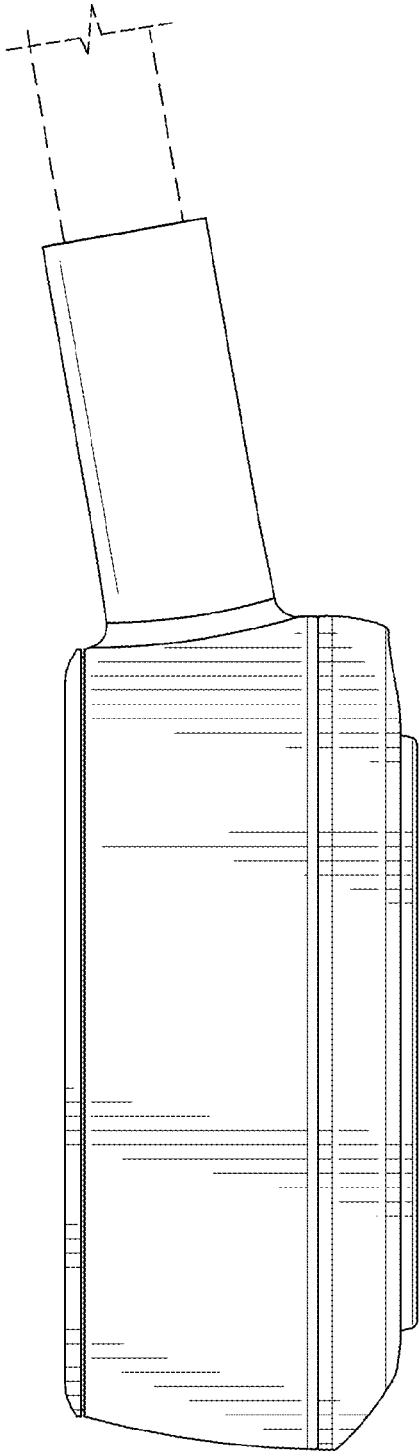

FIG. 8