



- (51) International Patent Classification:
G02B 6/44 (2006.01) *G02B 6/38* (2006.01)
- (21) International Application Number:
PCT/US2017/064095
- (22) International Filing Date:
30 November 2017 (30.11.2017)
- (25) Filing Language: English
- (26) Publication Language: English
- (30) Priority Data:
62/526,011 28 June 2017 (28.06.2017) US
62/526,018 28 June 2017 (28.06.2017) US
62/526,195 28 June 2017 (28.06.2017) US

- (71) Applicant: CORNING RESEARCH & DEVELOPMENT CORPORATION; 1 Riverfront Plaza, Corning, New York 14831 (US).
- (72) Inventors: DANNOUX, Thierry Luc Alain; 18 le Petit Bel Ebat, 77210 Avon (FR). ELKINS, II, Robert Bruce; 6151 Dwayne Stames Drive, Hickory, North Carolina 28602 (US). ROSSON, Joel Christopher; 280 44th Avenue Circle NW, Hickory, North Carolina 28601 (US). WILCOX, Dayne; 769 Bay Tree Lane, El Cerrito, California 94530 (US). WIMMER, Michael; Korkedamm 24C, 12524 Berlin (DE). WOODY, Shane; 9804 Dominion Crest Drive, Charlotte, North Carolina 28269 (US). ZHANG, Zhiye; 1094 22nd St. NE, Apt. 202, Hickory, North Carolina 28601 (US).

(54) Title: MULTIPORTS AND OTHER DEVICES HAVING KEYED CONNECTION PORTS AND SECURING FEATURES AND METHODS OF MAKING THE SAME

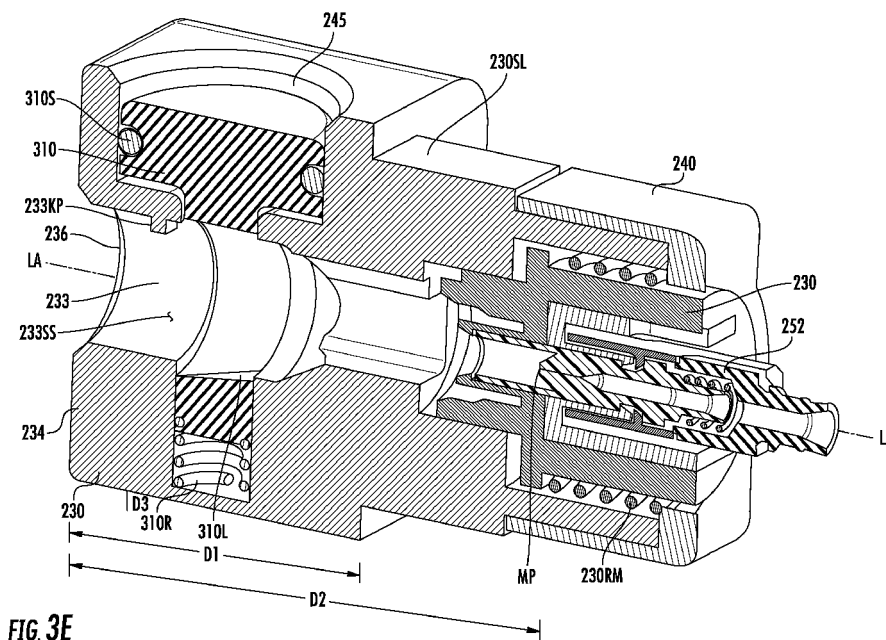

FIG. 3E

(57) Abstract: Devices such as multiports comprising connection ports with associated securing features and methods for making the same are disclosed. In one embodiment, the device comprises a shell, at least one connection port, at least one securing feature passageway, and at least one securing feature. The at least one connection port is disposed on the multiport with the at least one connection port comprising an optical connector opening extending from an outer surface of the multiport to a cavity of the multiport and defining a connection port passageway. The connection port passageway defines a keying portion. The at least one securing feature is associated with the connection port passageway, and the at least one securing feature is disposed within a portion of the at least one securing feature passageway.



(74) **Agent:** CARROLL, Michael E Jr.; Corning Cable Systems LLC, Intellectual Property Department, SP-TI-3-1, Corning, New York 14831 (US).

(81) **Designated States** (*unless otherwise indicated, for every kind of national protection available*): AE, AG, AL, AM, AO, AT, AU, AZ, BA, BB, BG, BH, BN, BR, BW, BY, BZ, CA, CH, CL, CN, CO, CR, CU, CZ, DE, DJ, DK, DM, DO, DZ, EC, EE, EG, ES, FI, GB, GD, GE, GH, GM, GT, HN, HR, HU, ID, IL, IN, IR, IS, JO, JP, KE, KG, KH, KN, KP, KR, KW, KZ, LA, LC, LK, LR, LS, LU, LY, MA, MD, ME, MG, MK, MN, MW, MX, MY, MZ, NA, NG, NI, NO, NZ, OM, PA, PE, PG, PH, PL, PT, QA, RO, RS, RU, RW, SA, SC, SD, SE, SG, SK, SL, SM, ST, SV, SY, TH, TJ, TM, TN, TR, TT, TZ, UA, UG, US, UZ, VC, VN, ZA, ZM, ZW.

(84) **Designated States** (*unless otherwise indicated, for every kind of regional protection available*): ARIPO (BW, GH, GM, KE, LR, LS, MW, MZ, NA, RW, SD, SL, ST, SZ, TZ, UG, ZM, ZW), Eurasian (AM, AZ, BY, KG, KZ, RU, TJ, TM), European (AL, AT, BE, BG, CH, CY, CZ, DE, DK, EE, ES, FI, FR, GB, GR, HR, HU, IE, IS, IT, LT, LU, LV, MC, MK, MT, NL, NO, PL, PT, RO, RS, SE, SI, SK, SM, TR), OAPI (BF, BJ, CF, CG, CI, CM, GA, GN, GQ, GW, KM, ML, MR, NE, SN, TD, TG).

Published:

- with international search report (Art. 21(3))
- with amended claims (Art. 19(1))

MULTIPOINTS AND OTHER DEVICES HAVING KEYED CONNECTION PORTS AND SECURING FEATURES AND METHODS OF MAKING THE SAME

CROSS-REFERENCE TO RELATED APPLICATIONS

[0001] This application claims the benefit of U.S. Application No. 62/451,221, filed on January 27, 2017, U.S. Application No. 62/428,212, filed on November 30, 2016, U.S. Application No. 62/428,219, filed on November 30, 2016, U.S. Application No. 62/428,224, filed on November 30, 2016, U.S. Application No. 62/428,230, filed on November 30, 2016, U.S. Application No. 62/451,234, filed on January 27, 2017, U.S. Application No. 62/526,011, filed on June 28, 2017, U.S. Application No. 62/526,018, filed on June 28, 2017, U.S. Application No. 62/428,234, filed on November 30, 2016, U.S. Application No. 62/428,244, filed on November 30, 2016, U.S. Application No. 62/428,252, filed on November 30, 2016, and U.S. Application No. 62/526,195, filed on June 28, 2017, the content of which is relied upon and incorporated herein by reference in entirety.

BACKGROUND

[0002] The disclosure is directed to devices providing at least one optical connection port along with methods for making the same. More specifically, the disclosure is directed to devices such as multiports comprising a keyed-connection port and a securing feature associated with the connection port for securing an optical connector along with methods of making the same.

[0003] Optical fiber is increasingly being used for a variety of applications, including but not limited to broadband voice, video, and data transmission. As bandwidth demands increase optical fiber is migrating deeper into communication networks such as in fiber to the premises applications such as FTTx, 5G and the like. As optical fiber extended deeper into communication networks the need for making robust optical connections in outdoor applications in a quick and easy manner was apparent. To address this need for making quick, reliable, and robust optical connections in communication networks hardened fiber optic connectors such as the OptiTap® plug connector were developed.

[0004] Multiports were also developed for making an optical connection with hardened connectors such as the OptiTap. Prior art multiports have a plurality of receptacles mounted through a wall of the housing for protecting an indoor connector

inside the housing that makes an optical connection to the external hardened connector of the branch or drop cable.

[0005] Illustratively, FIG. 1 shows a conventional fiber optic multiport 1 having an input fiber optic cable 4 carrying one or more optical fibers to indoor-type connectors inside a housing 3. The multiport 1 receives the optical fibers into housing 3 and distributes the optical fibers to receptacles 7 for connection with a hardened connector. The receptacles 7 are separate assemblies attached through a wall of housing 3 of the multiport 1. The receptacles 7 allow mating with hardened connectors attached to drop or branching cables (not shown) such as drop cables for “fiber-to-the-home” applications. During use, optical signals pass through the branch cables, to and from the fiber optic cable 4 by way of the optical connections at the receptacles 7 of multiport 1. Fiber optic cable 4 may also be terminated with a fiber optic connector 5. Multiports 1 allowed quick and easy deployment for optical networks.

[0006] Although, the housing 3 of the prior art multiport 1 is rugged and weatherable for outdoor deployments, the housings 3 of multiport 1 are relatively bulky for mounting multiple receptacles 7 for the hardened connector on the housing 3. Receptacles 7 allow an optical connection between the hardened connector such as the OptiTap male plug connector on the branch cable with a non-hardened connector such as the SC connector disposed within the housing 3, which provides a suitable transition from an outdoor space to an protected space inside the housing 3.

[0007] Receptacle 7 for the OptiTap connector is described in further detail in US Pat. No. 6,579,014. As depicted in US 6,579,014, the receptacle includes a receptacle housing and an adapter sleeve disposed therein. Thus, the receptacles for the hardened connector are large and bulky and require a great deal of surface array when arranged in an array on the housing 3 such as shown with multiport 1. Further, conventional hardened connectors use a separate threaded or bayonet coupling that requires rotation about the longitudinal axis of the connector and room for grabbing and rotating the coupling by hand when mounted in an array on the housing 3.

[0008] Consequently, the housing 3 of the multiport 1 is excessively bulky. For example, the multiport 1 may be too boxy and inflexible to effectively operate in smaller storage spaces, such as the underground pits or vaults that may already be crowded.

Furthermore, having all of the receptacles 7 on the housing 3, as shown in **FIG. 1**, requires sufficient room for the drop or branch cables attached to the hardened connectors attached to the multiport 1. While pits can be widened and larger storage containers can be used, such solutions tend to be costly and time-consuming. Network operators may desire other deployment applications for multiports 1 such as aerial, in a pedestal or mounted on a façade of a building that are not ideal for the prior art multiports 1 for numerous reasons such as congested poles or spaces or for aesthetic concerns.

[0009] Other multiports designs have been commercialized to address the drawbacks of the prior art multiports depicted in **FIG. 1**. By way of explanation, US 2015/0268434 discloses multiports 1' having one or more connection ports 9 positioned on the end of extensions 8 that project from the housing of the multiport 1' such as depicted in **FIG. 2**. Connection ports 9 of multiport 1' are configured for mating directly with a hardened connector (not shown) such as an OptiTap without the need to protect the receptacle 7 within a housing like the prior art multiport 1 of **FIG. 1**.

[0010] Although, these types of multiport designs such as shown in **FIG. 2** and disclosed in US 2015/0268434 allow the device to have smaller footprints for the housing 3', these designs still have concerns such as the space consumed by the relatively large ports 9 and associated space requirements of optical connections between the ports and hardened connector of the drop cables along with organizational challenges. Simply stated, the ports 9 on the extensions 8 of the multiport 1' and the optical connections between ports 9 and hardened connector occupy significant space at a location a short distance away from the multiport housing 3' such as within a buried vault or disposed on a pole. In other words, a cluster of optical ports 9 of multiport 1' are bulky or occupy limited space. The conventional hardened connectors used with multiport 1' also use a separate threaded or bayonet coupling that requires rotation about the longitudinal axis of the connector along with sufficient space for grabbing and rotating the coupling means by hand. Further, there are aesthetic concerns with the prior art multiports 1' as well.

[0011] Consequently, there exists an unresolved need for multiports that allow flexibility for the network operators to quickly and easily make optical connections in their optical network while also addressing concerns related to limited space, organization, or aesthetics.

SUMMARY

[0012] The disclosure is directed to devices comprising at least one connection port and a securing feature associated with the connection port. Devices that may use the concepts disclosed herein include multiports, closures or wireless devices. Methods of making the devices are also disclosed. The devices can have any suitable construction such as disclosed herein such a connection port that is keyed for inhibiting a non-compliant connector from being inserted and potentially causing damage to the device.

[0013] One aspect of the disclosure is directed to devices or multiports comprising a shell, at least one connection port, at least one securing feature passageway, and at least one securing feature. The at least one connection port is disposed on the multiport with the at least one connection port comprising an optical connector opening extending from an outer surface of the multiport to a cavity of the multiport and defining a connection port passageway. The connection port passageway defining a keying portion. The at least one securing feature is associated with the connection port passageway, where the at least one securing feature is disposed within a portion of the at least one securing feature passageway.

[0014] Another aspect of the disclosure is directed to devices or multiports comprising a shell, at least one connection port, at least one securing feature passageway, at least one securing feature, and at least one securing feature resilient member for biasing a portion of the at least one securing feature. The at least one connection port is disposed on the multiport with the at least one connection port comprising an optical connector opening extending from an outer surface of the multiport to a cavity of the multiport and defining a connection port passageway. The connection port passageway defining a keying portion. The at least one securing feature is associated with the connection port passageway, where the at least one securing feature is disposed within a portion of the at least one securing feature passageway.

[0015] Still another aspect of the disclosure is directed to devices or multiports comprising a shell, at least one connection port, at least one securing feature passageway, at least one securing feature. The at least one connection port is disposed on the

multiport with the at least one connection port comprising an optical connector opening extending from an outer surface of the multiport to a cavity of the multiport and defining a connection port passageway. The connection port passageway defining a keying portion. The at least one securing feature is associated with the connection port passageway, where the at least one securing feature is disposed within a portion of the at least one securing feature passageway, and the at least one securing feature is capable of translating within a portion of the at least one securing feature passageway.

[0016] Yet another aspect of the disclosure is directed to devices or multiports comprising a shell, at least one connection port, at least one securing feature passageway, at least one securing feature. The at least one connection port is disposed on the multiport with the at least one connection port comprising an optical connector opening extending from an outer surface of the multiport to a cavity of the multiport and defining a connection port passageway. The connection port passageway defining a keying portion. The at least one securing feature is associated with the connection port passageway, and the at least one securing feature comprises a bore, where the at least one securing feature is disposed within a portion of the at least one securing feature passageway, and the at least one securing feature is capable of translating within a portion of the at least one securing feature passageway.

[0017] A further aspect of the disclosure is directed to devices or multiports comprising a shell, at least one connection port, at least one securing feature passageway, at least one securing feature. The at least one connection port is disposed on the multiport with the at least one connection port comprising an optical connector opening extending from an outer surface of the multiport to a cavity of the multiport and defining a connection port passageway. The connection port passageway defining a keying portion. The at least one securing feature is associated with the connection port passageway, and the at least one securing feature comprises a bore, where the at least one securing feature is disposed within a portion of the at least one securing feature passageway, and the at least one securing feature is capable of translating within a portion of the at least one securing feature passageway wherein the at least one securing feature translates from a retain position to an open position as a suitable fiber optic connector is inserted into the at least one connection port.

[0018] Still another aspect of the disclosure is directed to devices or multiports comprising a shell, at least one connection port, at least one securing feature passageway, at least one securing feature. The at least one connection port is disposed on the multiport with the at least one connection port comprising an optical connector opening extending from an outer surface of the multiport to a cavity of the multiport and defining a connection port passageway. The connection port passageway defining a keying portion. The at least one securing feature is associated with the connection port passageway, and the at least one securing feature comprises a bore and a locking feature, where the at least one securing feature is disposed within a portion of the at least one securing feature passageway, and the at least one securing feature is capable of translating within a portion of the at least one securing feature passageway wherein the at least one securing feature translates from a retain position to an open position as a suitable fiber optic connector is inserted into the at least one connection port.

[0019] Other aspects of the disclosure are directed to devices or multiports comprising a shell, at least one connection port, at least one securing feature passageway, at least one securing feature. The at least one connection port is disposed on the multiport with the at least one connection port comprising an optical connector opening extending from an outer surface of the multiport to a cavity of the multiport and defining a connection port passageway. The connection port passageway defining a keying portion. The at least one securing feature is associated with the connection port passageway, and the at least one securing feature comprises a locking member and an actuator, where the at least one securing feature is disposed within a portion of the at least one securing feature passageway, and the at least one securing feature translates from a retain position to an open position as a suitable fiber optic connector is inserted into the at least one connection port.

[0020] A still further aspect of the disclosure is directed to a wireless device comprising a shell, at least one connection port, at least one securing feature passageway, at least one securing feature. The at least one connection port is disposed on the wireless device, the at least one connection port comprising an optical connector opening extending from an outer surface of the wireless device into a cavity of the wireless device and defining a connection port passageway. The connection port passageway defining a

keying portion. The at least one securing feature is associated with the connection port passageway, and the at least one securing feature comprises a locking member and an actuator, where the at least one securing feature is disposed within a portion of the at least one securing feature passageway. The connection port of the wireless device may also comprise other features, structures or components as disclosed herein.

[0021] Additional features and advantages will be set forth in the detailed description which follows, and in part will be readily apparent to those skilled in the art from that description or recognized by practicing the same as described herein, including the detailed description that follows, the claims, as well as the appended drawings.

[0022] It is to be understood that both the foregoing general description and the following detailed description present embodiments that are intended to provide an overview or framework for understanding the nature and character of the claims. The accompanying drawings are included to provide a further understanding of the disclosure, and are incorporated into and constitute a part of this specification. The drawings illustrate various embodiments and together with the description serve to explain the principles and operation.

BRIEF DESCRIPTION OF THE FIGURES

[0023] **FIGS. 1 and 2** are prior art multiports;

[0024] **FIGS. 3A and 3B** respectively depict top and bottom perspective views of an assembled device such as a multiport comprising at least one connection port defined by a respective optical connector opening disposed in a connection port insert of the multiport along with a securing feature associated with the connection port passageway;

[0025] **FIG. 3C** depicts a partially exploded view of another device such as a multiport comprising at least one connection port defined by an optical connector opening disposed in a connection port insert of the multiport along with a securing feature associated with the connection port passageway;

[0026] **FIGS. 3D-3F** depict various assembly views showing the connection port insert of the multiport of **FIG. 3C**;

[0027] **FIGS. 4A and 4B** respectively depict top and bottom perspective views of an assembled device such as a multiport comprising at least one connection port defined by

a respective optical connector opening disposed in a shell of the multiport along with a securing feature associated with the connection port passageway;

[0028] **FIG. 5** depicts a bottom perspective view of the representative multiport of **FIGS. 4A and 4B** with a portion of the shell opened for showing the internal construction of the multiport with one rear (internal) connector shown and the optical fibers removed for clarity;

[0029] **FIG. 6** is a bottom perspective view of the multiport of **FIG. 5** with a portion of the shell removed and a plurality of rear connectors and the optical fibers shown;

[0030] **FIG. 7** is a partially exploded view of the multiport of **FIG. 5** showing one of the rear connectors removed from the adapter and having the optical fibers removed for clarity;

[0031] **FIG. 7A** is a perspective view of an input tether that may be secured at an input connection port of devices;

[0032] **FIG. 7B** is a perspective view of a device comprising the input tether secured at the input connection port;

[0033] **FIG. 8** is a longitudinal cross-sectional view of a portion of the multiport of **FIG. 5** depicting the connection port with a keying portion and associated securing feature;

[0034] **FIG. 9** is a longitudinal cross-sectional view of a portion of the multiport of **FIG. 5** depicting an optical connector disposed in the connection port and retained by the securing feature;

[0035] **FIG. 10** is a transverse cross-sectional view of the multiport of **FIG. 5** taken through the securing features with a rear optical connector disposed in one of the optical connection ports;

[0036] **FIG. 11** is a detailed transverse cross-sectional view of the multiport of **FIG. 5** showing a securing feature passageway with a securing feature disposed therein and an adjacent securing feature passageway without a securing feature disposed therein;

[0037] **FIGS. 12-14** are various perspective views of the securing features of the multiport of **FIG. 5**;

[0038] **FIG. 15** is a bottom perspective view of the shell of the multiport of **FIG. 5** comprising a first portion and a second portion;

[0039] FIGS. 16-18 are various views of a first portion of the shell of FIG. 12;

[0040] FIG. 19 is a perspective view of the securing feature being installed into the securing feature passageway of the shell of the multiport of FIG. 5;

[0041] FIG. 20 is a perspective view of an adapter being installed into the shell of the multiport of FIG. 5;

[0042] FIG. 21 is a longitudinal cross-sectional view of a portion of the optical connection port with a keying portion of FIG. 16 shown upside down with the rear connector removed from the adapter;

[0043] FIGS. 22 depicts the adapters disposed within a portion of the shell of the multiport of FIG. 5 and being secured in place by an adapter retainer;

[0044] FIG. 23 is a partially exploded view showing one type of rear connector removed from the adapter along with the alignment sleeve retainer and the ferrule sleeve;

[0045] FIG. 23A is an assembled sectional view showing the rear connector of FIG. 23 attached to the adapter along with the ferrule sleeve retainer and the ferrule sleeve installed for aligning mating ferrules;

[0046] FIG. 24 is a perspective view of the rear connector of FIG. 23 with the ferrule sleeve retainer and ferrule sleeve aligned on the rear connector;

[0047] FIGS. 24A-24D depict various views of another construction for the rear connector that is received in the adapter and may be used with the concepts disclosed;

[0048] FIGS. 24E and 24F depict various views of yet another arrangement for the rear connector that is received directly into a portion of the shell that may be used with the concepts disclosed;

[0049] FIGS. 24G-24I depict various views of still another construction for the rear connector that is received directly into a portion of the shell that may be used with the concepts disclosed;

[0050] FIG. 25 is a longitudinal cross-sectional view of a portion of the optical connection port of FIG. 16 with the rear connector attached to the adapter;

[0051] FIG. 26 is a partial assembled view of components within the first portion of the shell of FIG. 16 with the rear connector attached and a plurality of securing feature resilient members positioned on respective securing features;

[0052] **FIGS. 27 and 28** depict perspective views of another explanatory device such as a multiport comprising at least one connection port defined by an optical connector opening disposed in a shell of the multiport for receiving one or more fiber optic connectors according to the concepts disclosed;

[0053] **FIGS. 28A-28E** are respective assembled and partially exploded perspective views of a device similar to the device of **FIGS. 27 and 28**, and comprising a connection port insert having at least one connection port defined by an optical connector opening and a securing feature associated with the connection port according to concepts disclosed;

[0054] **FIG. 29** depicts a bottom perspective view of the multiport of **FIGS. 27 and 28** with an open shell for showing the internal construction of the multiport with the rear (internal) connector and the optical fibers removed for clarity;

[0055] **FIG. 30** is a partially exploded view of the multiport of **FIGS. 27 and 28** showing one of the rear connectors removed from the adapter and having the optical fibers removed for clarity;

[0056] **FIGS. 31 and 32** are longitudinal cross-sectional views of the multiport of **FIGS. 27 and 28** taken along the connection port in the vertical direction for showing assembly details of the securing feature respectively in an inverted position and an upright position with a portion of the shell removed;

[0057] **FIG. 33** is a longitudinal vertical cross-sectional view of the multiport of **FIGS. 27 and 28** with an optical connector disposed and retained within the connection port having a keying portion using the securing feature;

[0058] **FIG. 34** is a detailed transverse cross-sectional view of the multiport of **FIGS. 27 and 28** taken through the securing features for showing details of the construction;

[0059] **FIGS. 35** is a detailed horizontal longitudinal cross-sectional view of the securing feature of the multiport of **FIGS. 27 and 28** retaining a fiber optic connector within the connection port passageway;

[0060] **FIG. 36** is a detailed perspective view of the securing features of the multiport of **FIGS. 27 and 28** removed from the shell with a fiber optic connector being retained by one of the securing features cooperating with the locking feature of the connector;

- [0061] FIGS. 37-39 are various perspective views of the actuator of the securing feature assembly of the multiport of FIGS. 27 and 28;
- [0062] FIG. 40 is a perspective view of the securing member blank for forming the securing member of the securing feature of FIGS. 41-43;
- [0063] FIGS. 41-43 are various perspective views showing an explanatory securing member for the securing feature assembly of FIGS. 27 and 28 showing details of the same;
- [0064] FIGS. 44 and 45 are bottom and top perspective views showing the optical fiber guide configured as a tray of FIGS. 27 and 28;
- [0065] FIG. 46 is a bottom perspective view of a first portion of the shell of the multiport of FIGS. 27 and 28;
- [0066] FIG. 47 is a perspective view of the second portion of the shell of the multiport of FIGS. 27 and 28;
- [0067] FIGS. 48 and 49 respectively are partially exploded and assembled views of an explanatory securing feature sub-assembly for the securing members;
- [0068] FIG. 50 depicts the components of securing features being installed into the first portion of the shell of FIG. 46;
- [0069] FIGS. 51 and 52 respectively are perspective view and a sectional view showing an optical fiber guide being installed into the first portion of the shell of the multiport of FIGS. 27 and 28;
- [0070] FIG. 53 is a perspective view of a plurality of adapters and an adapter retainer being aligned for installation into the first portion of the shell of the multiport of FIGS. 27 and 28;
- [0071] FIG. 54 is a perspective view of the plurality of adapters and an adapter retainer assembled into the first portion of the shell of the multiport of FIGS. 27 and 28;
- [0072] FIG. 55 is a perspective view of the second portion of the shell being aligned with the first portion of the shell of the multiport of FIGS. 27 and 28 with the rear connectors and optical fibers removed for clarity;
- [0073] FIG. 56 is a detailed perspective view showing details of the interlocking features between the first portion and the second portion of the shell of the multiport of FIGS. 27 and 28;

[0074] **FIGS. 57-60** depict perspective views for another securing feature comprising more than one component for devices according to the concepts disclosed along with a suitable housing for a fiber optic connector having an integral locking feature that cooperates with the securing feature;

[0075] **FIGS. 61 and 62** are perspective views of the securing feature and connector housing for the fiber optic connector of **FIGS. 57-60** as disposed in a device;

[0076] **FIGS. 63-65** depict perspective views for yet another securing feature comprising more than one component for devices according to the concepts disclosed along with a suitable connector housing for a fiber optic connector having an integral locking feature that cooperates with the securing feature;

[0077] **FIGS. 66-68** depict perspective views of yet another securing feature comprising more than one component for devices according to the concepts disclosed along with a suitable connector housing for a fiber optic connector having an integral locking feature that cooperates with the securing member;

[0078] **FIG. 69** is a sectional view showing the securing feature and connector housing of the fiber optic connector of **FIG. 68** disposed in a device;

[0079] **FIGS. 70-72** depict perspective views of yet another securing feature comprising more than one component for devices according to the concepts disclosed;

[0080] **FIG. 73** is a sectional view of a further securing feature showing that the securing feature may be arranged at any suitable angle relative to a longitudinal axis of the connector port;

[0081] **FIGS. 74** depicts a device with the actuator of the securing feature disposed in a horizontal direction that is generally aligned with the longitudinal axis of the connection port;

[0082] **FIG. 74A** is a perspective view of another securing feature construction without the multiport removed and securing the connector for showing the actuator of the securing feature of a device arranged in a direction that is generally aligned with the longitudinal axis of the connection port;

[0083] **FIG. 74B** are perspective views of the securing feature of **FIG. 74A** being placed into a device;

[0084] FIGS. 75-82 are various views depicting the device of FIG. 74 with the actuator of the securing feature arranged in a direction that is generally aligned with the longitudinal axis of the connector port;

[0085] FIG. 83 is a top view of another device such as a multiport having connection ports disposed on both a first end and a second end of the device;

[0086] FIGS. 84-88 are various views of another device having connection ports disposed in stacked rows according to the concepts disclosed;

[0087] FIGS. 89-91 are various views of still another device having connection ports disposed in stacked rows that are offset according to the concepts disclosed;

[0088] FIGS. 92-96 are various views of still another device having connection ports disposed in stacked rows that are offset and arranged on an angled surface according to the concepts disclosed;

[0089] FIGS. 97 and 98 are perspective views of a first cover that may be used with the devices disclosed herein;

[0090] FIGS. 99-101 are perspective views of a second cover that cooperates with a bracket that may be used with the devices disclosed herein;

[0091] FIG. 102 is a perspective view of a wireless device comprising at least one connector port and a securing member according to the concepts disclosed herein; and

[0092] FIG. 103 is a perspective view of a closure comprising at least one connector port and a securing member according to the concepts disclosed herein.

DETAILED DESCRIPTION

[0093] Reference will now be made in detail to the embodiments of the disclosure, examples of which are illustrated in the accompanying drawings. Whenever possible, like reference numbers will be used to refer to like components or parts.

[0094] The concepts for the devices disclosed herein are suitable for providing at least one optical connection to a device for indoor, outdoor or other environments as desired. Generally speaking, the devices disclosed and explained in the exemplary embodiments are multiports, but the concepts disclosed may be used with any suitable device as appropriate. As used herein, the term “multiport” means any device comprising at least one connection port for making an optical connection and a securing feature associated with the at least one connection port. By way of example, the multiport may

be any suitable device having at least one optical connection such as a passive device like an optical closure (hereinafter “closure”) or an active device such as a wireless device having electronics for transmitting or receiving a signal.

[0095] The concepts disclosed advantageously allow compact form-factors for devices such as multiports comprising at least one connection port comprising a keying portion and the securing feature associated with the connection port. The concepts are scalable to many connection ports on a device in a variety of arrangements or constructions. The securing features disclosed herein for devices engage directly with a portion of connector without conventional structures like prior art devices that require the turning of a coupling nut, bayonet or the like. As used herein, “securing feature” excludes threads and features that cooperate with bayonets on a connector. Thus, the devices disclosed may allow connection port to be closely spaced and may result in small devices since the room need for turning a threaded coupling nut or bayonet is not necessary. The compact form-factors may allow the placement of the devices in tight spaces in indoor, outdoor, buried, aerial, industrial or other applications while providing at least one connection port that is advantageous for a robust and reliable optical connection in a removable and replaceable manner. The disclosed devices may also be aesthetically pleasing and provide organization for the optical connections in manner that the prior art multiports cannot provide.

[0096] The devices disclosed are simple and elegant in their designs. The devices disclosed comprise at least one connection port with a keying portion and a securing feature associated with the connection port that is suitable for retaining an external fiber optic connector received by the connection port. The keying portion of the connection port cooperates with a key on a complimentary external fiber optic connector to inhibit damage to the connection port by inhibiting the insertion of a non-compliant connector. The keying portion may also aid the user during blind insertion of the connector into the connection port of the device to determine the correct rotational orientation with respect to the connection port when a line of sight is not possible or practical for alignment. Illustratively, **FIG. 18** depicts a representative connection port passageway 233 comprising a keying portion 233KP. As shown, the keying portion 233KP is an additive keying portion to the primitive geometric round shape of the connection port passageway

233 such as a male key (not labeled) that is disposed forward of the securing feature in the connection port passageway 233. However, the concepts for the connection ports 236 of devices may be modified for different connector designs. For instance, the keying portion 233KP may be defined as a walled-portion across part of the connection port passageway 233 as represented by the dashed line 233KP'. Thus, the connection port with keying portion 233KP' would be able to properly receive an external fiber optic connector having a portion with a proper D-shaped portion. The keying portion 233KP is illustrated in appropriate FIGS., but will not be discussed with every depiction for the sake of brevity. Unlike prior art multiports, the concepts disclosed advantageously allow the quick and easy connection and retention by inserting the fiber optic connectors directly into the connection port of the device without the need or space considerations for turning a threaded coupling nut or bayonet for retaining the external fiber optic connector. Generally speaking, the securing features disclosed for use with devices herein may comprise one or more components with at least one component translating for releasing or securing the external fiber optic connector to the device. As used herein, the term "securing feature" excludes threaded portions or features for securing a bayonet disposed on a connector.

[0097] Since the connector footprint used with the devices disclosed does not require the bulkiness of a coupling nut or bayonet, the fiber optic connectors used with the devices disclosed herein may be significantly smaller than conventional connectors used with prior art multiports. Moreover, the present concepts for connection ports on devices allows an increased density of connection ports per volume of the shell since there is no need for accessing and turning the coupling nut or bayonets by hand for securing a fiber optic connector like the prior art multiports.

[0098] The devices disclosed comprise a securing feature for directly engaging with a suitable portion of a connector housing of the external fiber optic connector or the like for securing an optical connection with the device. Different variations of the concepts are discussed in further detail below. The structure for securing the fiber optic connectors in the devices disclosed allows much smaller footprints for both the devices and the fiber optic connectors along with a quick-connect feature. Devices may also have a dense spacing of connection ports if desired. The devices disclosed advantageously allow a

relatively dense and organized array of connection ports in a relatively small form-factor while still being rugged for demanding environments. As optical networks increase densifications and space is at a premium, the robust and small-form factors for devices such as multiports, closures and wireless devices disclosed herein becomes increasingly desirable for network operators.

[0099] The concepts disclosed herein are suitable for optical distribution networks such as for Fiber-to-the-Home applications, but are equally applicable to other optical applications as well including indoor, automotive, industrial, wireless, or other suitable applications. Additionally, the concepts disclosed may be used with any suitable fiber optic connector footprint that cooperates with the securing feature of the device. Various designs, constructions, or features for devices are disclosed in more detail as discussed herein and may be modified or varied as desired. In one variation, the connection port may have a keying portion for inhibiting the insertion of non-compliant connectors that may damage the device.

[00100] The devices disclosed may locate the at least one connection port 236 in different portions or components of the device as desired. **FIGS. 3A and 3B** respectively depict top and bottom perspective view of explanatory multiports 200 comprising at least one connection port 236 disposed on a connection port insert 230 for making optical connections. Generally speaking, when assembled a portion of the connection port insert 230 is disposed within a shell 210. **FIGS. 4A and 4B** respectively depict top and bottom perspective views of other explanatory multiports 200 comprising at least one connection port 236 being a portion of a shell of the device. By way of explanation, at least one connection ports 236 is molded as a portion of shell 210. Although, these concepts are described with respect to multiports the concepts may be used with any other suitable devices such as wireless devices (**FIG. 102**), closures (**FIG. 103**) or other suitable devices.

[00101] Generally speaking, devices such as multiport 200 comprise a shell 210 comprising a body 232 and one or more connection ports 236 disposed on a first end or portion 212 of multiport 200. The connection ports 236 are configured for receiving and retaining external fiber optic connectors 10 such as shown in **FIG. 3A** for making optical connections with the multiport 200. Connection ports 236 each comprises a respective

optical connector opening 238 extending from an outer surface 234 of the multiport 200 into a cavity 216 of the multiport 200 and defining a connection port passageway 233. At least one securing feature 310 is associated with the connection port passageway 233 for cooperating with the external fiber optic connector 10. The securing feature may translate for releasing or securing the external fiber optic connector 10. One or more respective securing feature passageways 245 such as shown in **FIG. 3C**, **FIG. 7** or **FIG. 32** extend from the outer surface 234 of multiport 200 to a portion of the respective connection port passageways 233 of the multiport 200. Respective securing features 310 are associated with the connection port passageways 233 and may be disposed within a portion of the securing feature passageway 245 of the multiport 200.

[00102] Optical connections to the devices are made by inserting one or more suitable external fiber optic connectors 10 into respective connection port passageways 233 as desired. Specifically, the connection port passageway 233 is configured for receiving a suitable external fiber optic connector 10 (hereinafter connector) of a fiber optic cable assembly 100 (hereinafter cable assembly). Connection port passageway 233 is associated with a securing feature 310 for retaining (e.g., securing) connector 10 in the multiport 200. The securing feature 310 advantageously allows the user to make a quick and easy optical connection at the connection port 236 of multiport 200. The securing feature 310 may operate for providing a connector release feature when actuated.

[00103] Specifically, the connector 10 may be retained within the respective connection port 236 of the device by pushing and fully-seating the connector 10 within the connection port 236. To release the connector 10 from the respective connection port 236, the securing feature 310 is actuated releasing the securing feature from the connector housing and allow the connector to be removed from the connection port 236. Stated another way, the at least one securing feature 310 is capable of releasing the connector 10 when translating within a portion of a securing feature passageway 245. The full insertion and automatic retention of the connector 10 may advantageously allow one-handed installation of the connector 10 by merely pushing the connector into the connection port 236. The devices disclosed accomplish this connector retention feature upon full-insertion by biasing the securing feature to a retain position. However, other modes of operation for retaining and releasing the connector 10 are possible according to

the concepts disclosed. For instance, the securing feature 310 may be designed to require actuation for inserting the connector 10; however, this may require a two-handed operation.

[00104] Securing feature 310 may be designed for holding a minimum pull-out force for connector 10. In some embodiments, the pull-out force may be selected to release the connector 10 before damage is done to the device or the connector 10. By way of example, the securing feature 310 associated with the connection port 236 may require a pull-out force of about 50 pounds (about 220N) before the connector 10 would release. Likewise, the securing feature 310 may provide a side pull-out force for connector 10 for inhibiting damage as well. By way of example, the securing feature 310 associated with the connection port 236 may provide a side pull-out force of about 25 pounds (about 110N) before the connector 10 would release. Of course, other pull-out forces such as 75 pounds (about 330N) or 100 (about 440N) pounds are possible along with other side pull-out forces.

[00105] The securing features 310 disclosed herein may take many different constructions or configurations. By way of explanation, securing features 310 may be formed from a single component as shown in **FIG. 3C** or a plurality of components as shown in **FIG. 30**. Furthermore, the securing features 310 or portions of securing features 310 may be constructed as sub-assemblies such as shown in **FIG. 50** for easy assembly of multiple securing features 310 or other design considerations.

[00106] Devices such as multiports 200, wireless devices 500 (**FIG. 102**), or closures 700 (**FIG. 103**) can have different constructions for securing features, shells, rear connectors, input ports, splitters, keying portions for connection ports, tethers, electronics or components according to the concepts disclosed herein. Generally speaking, the devices comprise at least one connection port 236 defined by an optical connector opening 238 extending into a cavity of the device 200, 500, 700 along with a securing feature 310 associated with the connection port 236.

[00107] **FIGS. 3A and 3B** depict a device where the one or more connection ports 236 and the one or more securing feature passageways 245 are a portion of a connector port insert 230. Connector port insert 230 is at least partially inserted into shell 210 as represented by the dashed line. Specifically, the dashed line represents a parting line PL

between the connector port insert 230 and the shell 210. Shell 210 may take many different forms as disclosed herein as well. Other devices may have the one or more connection ports 236 and the one or more securing feature passageways 245 formed as a portion of the shell 210, instead of being at least partially inserted into shell as an assembly.

[00108] **FIG. 3C** is a partially exploded view of another device 200 similar to the multiport 200 of **FIGS. 3A and 3B**. **FIG. 3C** depicts the multiport 200 comprising at least one connection port 236 disposed on the multiport 200 with the connection port 236 defined by an optical connector opening 238 extending from an outer surface 234 of the multiport 200 into a cavity 216 of the multiport 200 and defining a connection port passageway 233. Multiport 200 also comprises at least one securing feature 310 associated with the connection port passageway 233. Connection port insert 230 also comprises at least one securing feature passageway 245 for receiving the securing feature 310. As depicted in **FIG. 3F**, the securing feature passageways 245 extend from the outer surface 234 of multiport 200 to the respective connection port passageways 233 of the multiport 200. Multiport 200 of **FIG. 3C** comprises a shell 210 with a portion of the connection port insert 230 sized for fitting into a first opening of the shell 210 that leads to a cavity 216. Multiport 200 of **FIG. 3C** also comprises a plurality of adapters 230A for receiving respective rear connectors 252 in alignment with the respective connection port 236. In this embodiment, a plurality of securing feature locking members 310LM are used retaining the securing features 310 in the securing feature passageway 245 as best shown in **FIG. 3F**. The multiport 200 may also comprise a fiber tray (not numbered) for routing and organizing the optical fibers. The fiber tray inhibits damage to optical fibers and also provides a location for the mounting of other components such as splitters, electronics or the like. The fiber tray shown in **FIG. 3C** attaches to one or more slots formed in a retainer 240, which is used for securing adapters to the connection port insert 230.

[00109] **FIG. 3D** shows an assembly comprising the connection port insert 230 with securing features 310 installed and the rear connectors 252 attached and **FIG. 3E** shows a cross-section through the connection port passageway 233. As depicted, this connection port passageway 233 comprises a keying portion 233KP as part of the connection port

insert 230. As shown, keying portion 233KP is disposed forward of the securing feature 310 in the connection port passageway 233. Further, the keying portion 233KP or 233KP' may have any suitable location in the connection port passageway forward of the securing feature. The optical fibers 250 have been removed from rear connectors 252 of **FIGS. 3C and 3D** for clarity. As depicted, the assembly has the securing features 310 associated with each connection port passageway 233 disposed within a portion of the securing feature passageway 245. In this embodiment, the securing feature 310 is a push-button actuator formed as a single component.

[00110] As shown in **FIG. 3E**, securing feature 310 is biased to a retain position. Specifically, the securing feature 310 is biased in an upward direction using a securing feature resilient member 310R, which is disposed within the connection port insert 230 below the securing feature 310. Consequently, securing feature 310 is capable of translating within a portion of the securing feature passageway 245. As depicted, a sealing feature 310S is disposed on the securing feature 310. Sealing feature 310S provides a seal between the securing feature 310 and the securing feature passageway 245 to inhibit dirt, dust and debris from entering the device.

[00111] Multiport 200 of **FIG. 3C** also comprises at least one adapter 230A aligned with the respective connection port 236. Adapter 230A is suitable for securing a rear connector 252 thereto for aligning the rear connector 252 with the connection port 236. One or more optical fibers 252 (not shown) may be routed from the connection port 236 toward an input connection port 260 of the multiport 200. For instance, the rear connector 252 may terminate the optical fiber 250 for optical connection at connection port 236 and route the optical fiber 250 to the input connection port 260. In this embodiment, adapters 230A are secured to connection port insert 230 using retainer 240. Adapters 230A may be biased using a resilient member 230RM as shown. Rear connectors 252 may take any suitable form and be aligned and secured with the connection ports 236 in any suitable manner. As used herein, "input connection port" is the location where external optical fibers are received or enter the device, and the input connection port does not require the ability to make an optical connection.

[00112] In this embodiment, the securing feature 310 comprises a bore 310B that is aligned with the least one connection port passageway 233 when assembled as shown in

FIG. 3E. Bore 310B is sized for receiving a suitable connector 10 therethrough for securing the same for optical connectivity. Bores or openings through the securing feature 310 may have any suitable shape or geometry for cooperating with its respective connector. As used herein, the bore may have any suitable shape desired including features on the surface of the bore for engaging with a connector.

[00113] In some embodiments, the securing feature 310 is capable of moving to an open position when inserting a suitable connector 10 into the connection port passageway 233. When the connector 10 is fully-inserted into the connector port passageway 233, the securing feature 310 is capable of moving to the retain position automatically. Consequently, the connector 10 is secured within the connection port 236 by securing feature 310 without turning a coupling nut or a bayonet like the prior art multiports. Stated another way, the securing feature 310 translates from the retain position to an open position as a suitable connector 10 is inserted into the connection port 236. The securing feature passageway 245 is arranged transversely to a longitudinal axis LA of the multiport 200, but other arrangements are possible. Other securing features may operate in a similar manner, but use an opening instead of a bore that receives the connector therethrough.

[00114] As shown in **FIG. 3E**, securing feature 310 comprises a locking feature 310L. Locking feature 310L cooperates with a portion of the connector 10 when it is fully-inserted into the connection port 236 for securing the same. Specifically, the connector housing 20 of connector 10 may have a cooperating geometry that engages the locking feature 310L of securing feature 310. In this embodiment, locking feature 310L comprises a ramp (not numbered). The ramp is integrally formed at a portion of the bore 310B with the ramp angling up when looking into the connection port 236. The ramp allows the connector 10 to push and translate the securing feature 310 downward against the securing feature resilient member 310R as the connector 10 is inserted in the connection port 236 as shown. Ramp may have any suitable geometry. Once the locking feature 310L of the securing feature 310 is aligned with the cooperating geometry of the locking feature 20L of connector 10, then the securing feature 310 translates so that the locking feature 310L engages the locking feature 20L of connector 10. **FIGS. 8 and 9**

depict a similar securing feature 310 illustrating the concepts with and without a connector 20.

[00115] Locking feature 310L comprises a retention surface 310RS. In this embodiment, the back-side of the ramp of locking feature 310L forms a ledge that cooperates with complimentary geometry on the connector housing 20 of connector 10. However, retention surface 310RS may have different surfaces or edges that cooperate for securing connector 10 for creating the desired mechanical retention. For instance, the retention surface 310RS may be canted or have a vertical wall for tailoring the pull-out force for the connection port 236. However, other geometries are possible for the retention surface 310RS. Additionally, the connection port 236 has a sealing location at a connection port passageway sealing surface 233SS with the connector 10 that is located closer to the optical connector opening 238 at the outer surface 234 than the securing feature 310 or locking feature 310L. Illustratively, connection port 236 has connection port passageway sealing surface 233CS for the connector 10 disposed at a distance D_3 from the optical connector opening 238 and the locking feature 310L and securing feature 310 are disposed at a distance further into the connection port passageway 233 than distance D_3 such as shown in FIG. 3E.

[00116] Other types of securing members 310 disclosed herein may operate in a similar manner for securing connector 10, but comprise more than one component such as an actuator 310A that cooperates with a securing member 310M such as disclosed herein. Additionally, the use of more than one component allows other arrangements for the securing feature passageway 245 relative to a longitudinal axis LA of the device.

[00117] The connection port insert 230 comprises a body having a front face FF and a plurality of connection ports 236. Each connection port 236 has an optical connector opening 238 extending from the front face FF into the connection port insert 230 with a connection port passageway 233 extending through part of the connection port insert 230 to a rear face RF (not visible) of the connection port insert 230. Connection port insert 230 is sized so that at least a portion of the connection port insert 230 fits into a first opening of the shell 210 such as as shown in FIG. 28E. As shown, the connection port passageway 233 comprises a keying portion 233KP disposed forward of the securing feature 310 in connection port passageway. The sealing location of the connector port

insert 230 with the shell (210) comprises a sealing surface (233SS) disposed a first distance (D1) inward from the outer surface (234) of the device and disposed on a portion of connection port passageway 233. The adapters 230A align the rear connectors 252 at a connector mating position MP disposed inward from the outer surface (234) of the multiport at a distance D2, where the second distance (D2) is greater than the first distance (D1). Additionally, the connection port insert 230 may comprise one or more components or include a feature for sealing with the shell 210 for making the multiport weatherproof. However, the devices could be made to be re-enterable if desired.

[00118] In more detail, connection port inserts 230 may also comprise a sealing location 230SL for providing a surface and location for making a weatherproof attachment to shell 210. Sealing location may be disposed at a first distance D1 from the front face 234 of the connector port insert 230. Sealing location is disposed at a suitable distance D1 for providing a suitable seal with the shell 210. Connection port inserts 230 also have a connector mating plane 230MP disposed at a second distance D2 from the front face 234. The connector mating plane 230MP is disposed within the cavity of the shell 210 of the multiport for protecting the connector mating interface. In some particular embodiments, the connector port insert 230 comprises a sealing location 230SL disposed at a first distance D1 from the front face 234 and the connector mating position 230MP is disposed at the second distance D2 from the front face 234 with the second distance D2 being greater than the first distance D1.

[00119] The sealing location 230SL may comprise a sealing element 290 disposed between the connection port insert 230 and the shell 210. The sealing locations 230SL may comprise respective grooves in the connector port insert 230 or end cap 280 if used. Grooves may extend about the perimeter of the connection port insert 230 and are located at respective distances D1 from the front face 234 of the connection port insert 230 and end cap 280. Grooves may receive one or more appropriately sized O-rings or gaskets 290A for weatherproofing multiport 200. The O-rings are suitably sized for creating a seal between the connection port insert 230 and the shell 210. By way of example, suitable O-rings may be a compression O-ring for maintaining a weatherproof seal. Other embodiments may use an adhesive or suitable welding of the materials for sealing the device.

[00120] Variations of multiports 200 depicted in **FIGS. 3A-3C** are possible as well. For instance, the multiports depicted in **FIGS. 3A-3C** can have other features or constructions using a second insert 230' that is similar to the connection port insert 230. For instance, the second insert 230' comprises a body 232 having a front face 234 comprising a plurality of connection ports 236 having an optical connector port opening 238 like the connection port insert 230. Second inserts 230' can have other configurations as well for use with the multiports disclosed herein.

[00121] Other embodiments are possible that do not use a connection port insert as described. By way of explanation, the one or more connector ports 230 and the one or more securing feature passageways 245 are a portion of the shell 210. Illustratively, **FIGS. 4A and 4B** depict multiport 200 comprising a shell 210 comprising a body 232 with one or more connection ports 236 disposed on a first end or portion 212 with each connection port 236 comprising a respective optical connector opening 238. The optical connector openings extend from an outer surface 234 of shell 210 of the multiport 200 into a cavity 216 and define a connection port passageway 233. One or more respective securing feature passageways 245 extend from the outer surface 234 of the shell 210 to a portion of the respective connection port passageways 233. A plurality of security features 310 are associated with the respective plurality of connection port passageways 233 and at least a portion of the securing features are disposed within a portion of respective securing feature passageways 245. Moreover, the multiports 200 disclosed may have any suitable number of connection ports 236, input connection ports 260 or the like using the concepts disclosed.

[00122] For the sake of brevity, the concepts will be illustrated and described in more detail with respect to the embodiment of **FIGS. 4A and 4B**, but it is understood that the structure or features disposed in the shell 210 may also be disposed in the connection port insert 230 depicted in **FIGS. 3A and 3B** as appropriate. Further, multiports according to the concepts disclosed may have any suitable number of ports as desired along with suitable optical fiber distribution, pass-throughs, or like.

[00123] **FIGS. 5-7** depict various views of multiport 200 of **FIGS. 4A and 4B** for explaining the concepts and the features may be used with other multiport designs as appropriate or modified with other concepts as appropriate or discussed herein. **FIGS. 8**

and 9 are longitudinal cross-sectional views respectively depicting the optical connection port 236 of the multiport 200 of **FIGS. 4A and 4B** with and without a connector 10 retained therein. **FIGS. 10 and 11** are transverse cross-sectional views of the multiport 200 of **FIGS. 4A and 4B** taken through the securing features 310.

[00124] **FIG. 5** depicts a bottom perspective view of a representative multiport 200 of **FIGS. 4A and 4B**. As depicted in this embodiment, shell 210 is formed by a first portion 210A and a second portion 210B. **FIG. 5** shows the second portion 210B of shell 210 removed from the first portion 210A for showing the internal construction of multiport 200. Multiport 200 is depicted with only one rear (internal) connector 252 shown and the optical fibers 250 removed for clarity purposes in **FIG. 5**.

[00125] Optical fibers 250 are routed from one or more of the plurality of connection ports 236 toward an input connection port 260 for optical communication within the multiport 200. Consequently, the input connection port 260 receives one or more optical fibers and then routes the optical signals as desired such as passing the signal through 1:1 distribution, routing through an optical splitter or passing optical fibers through the multiport. Optical splitters 275 (hereinafter "splitter(s)") such as shown in **FIG. 6** allow a single optical signal to be split into multiple signals such as 1xN split, but other splitter arrangements are possible such as a 2xN split. For instance, a single optical fiber may feed input connection port 260 and use a 1x8 splitter within the multiport 200 to allow eight connector ports 236 for outputs on the multiport 200. The input connection port 260 may be configured in a suitable manner with any of the multiports 200 disclosed herein as appropriate such as a single-fiber or multi-fiber port. Likewise, the connection ports 236 may be configured as a single-fiber port or multi-fiber port. For the sake of simplicity and clarity in the drawings, all of the optical fiber pathways may not be illustrated or portions of the optical fiber pathways may be removed in places so that other details of the design are visible.

[00126] **FIG. 6** shows multiport 200 of **FIG. 5** with the rear connectors 252 and optical fibers 250 routing through splitter 275 and **FIG. 7** is a partially exploded view of **FIG. 5**. Multiport 200 has one or more optical fibers 250 routed from the one or more connection ports 236 toward an input connection port 260 in a suitable fashion inside cavity 216. As best shown in **FIG. 9**, inside the cavity 216 of multiport 200 one or more

optical fibers 250 are aligned with the respective connection ports 236 for making an optical connection with connector 10. As shown, connector 10 comprises a connector housing 20 that has an O-ring 65 that cooperates with sealing location of the connector port 236 at a distance D3, which is located closer to the optical connector opening 238 than securing feature 310.

[00127] Although only one rear connector 252 is shown in **FIG. 5**, a plurality of rear connectors 252 (see **FIG. 6**) are aligned with the respective connector port passageways 233 from the rear portion 237 of connection port passageway 233 within the cavity 216 of the multiport 200. The rear connectors 252 are associated with one or more of the plurality of optical fibers 250. Each of the respective rear connectors 252 aligns and attaches to a structure such as the adapter 230A or other structure at the rear portion 237 of the connection port passageway 233 in a suitable matter. The plurality of rear connectors 252 may comprise a suitable rear connector ferrule 252F as desired and rear connectors 252 may take any suitable form from a simple ferrule that attaches to a standard connector type inserted into an adapter. By way of example, rear connectors 252 may comprise a resilient member for biasing the rear connector ferrule 252F or not. Additionally, rear connectors 252 may further comprise a keying feature.

[00128] In multiport 200 of **FIG. 6**, a single input optical fiber of the input connection port 260 is routed to a 1:4 splitter 275 and then each one of the individual optical fibers 250 from the splitter is routed to each of the respective four connection ports 236 for optical connection and communication within the multiport. Input connection port 260 may be configured in any suitable configuration for the multiports disclosed as desired for the given application. Examples of input connection ports 260 include being configured as a single-fiber input connection, a multi-fiber input connector, a tether input that may be a stubbed cable or terminated with a connector or even one of the connection ports 236 may function as a pass-through connection port as desired.

[00129] By way of explanation for multi-fiber ports, two or more optical fibers 250 may be routed from one or more of the plurality of connection ports 236 of the multiport 200 of **FIG. 5**. For instance, two optical fibers may be routed from each of the four connection ports 236 of multiport 200 toward the input connection port 260 with or without a splitter such as single-fiber input connection port 260 using a 1:8 splitter or by

using an eight-fiber connection at the input connection port 260 for a 1:1 fiber distribution. To make identification of the connection ports or input connection port(s) easier for the user, a marking indicia may be used such as text or color-coding of multiport or marking the input tether (e.g. an orange or green polymer) or the like.

[00130] Other configurations are possible besides an input connection port 260 that receives a connector 10 such as a tether cable that extends from the input port. Instead of using a input connection port that receives a connector 10, multiports 200 may be configured for receiving an input tether 270 attached to the multiport such as represented in FIG. 7.

[00131] FIG. 7A depicts an example of input tether 270 removed from a device. Input tether 270 has optical fibers 250 that enter the multiport 200 and are terminated with to rear connectors 252 for making an optical connection at the connection port 236. FIG. 7B is a perspective view of a representative multiport 200 having the input tether 270 secured at the input connection port 260. In this embodiment, there is no securing feature for the input connection port 260. However, other embodiments may retain the securing feature and secure the input tether 270 from inside the device.

[00132] If used, input tether 270 may terminate the other end with a fiber optic connector 278 as depicted or be a stubbed cable as desired. For instance, connector 278 may be an OptiTip® connector for optical connection to previously installed distribution cables; however, other suitable single-fiber or multi-fiber connectors may be used for terminating the input tether 270 as desired. Input tether 270 may be secured to the multiport 200 in any suitable manner such as adhesive, a collar or crimp, heat shrink or combinations of the same. The input tether 270 may also have stubbed optical fibers for splicing in the field if desired, instead of the connector 278.

[00133] Furthermore, the input tether 270 may further comprise a furcation body that has a portion that fits into the multiport 200 at the input port of the shell 210 or the connection port insert 230 such as into the optical connector opening 238 or bore 260B of the input connection port 260, but the furcation body may be disposed within the shell 210 if desired. The furcation body is a portion of the input tether that transitions the optical fibers 250 to individual fibers for routing within the cavity 216 of the shell 210 to the respective connector ports. As an example, a ribbon may be used for insertion into

the back end of the ferrule of fiber optic connector 278 and then be routed through the input tether 270 to the furcation body where the optical fibers are then separated out into individual optical fibers 250. From the furcation body the optical fibers 250 may be protected with a buffer layer or not inside the cavity 216 of the multiport 200 and then terminated on rear connector 252 as desired.

[00134] The input tether 270 may be assembled with the rear connectors 252 and/or fiber optic connector 278 in a separate operation from the assembly of multiport 200 if the rear connectors 252 fit through the input port. Thereafter, the rear connectors 252 may be individually threaded through a bore 260B of the input connection port 260 of the multiport or connection port insert 230 with the appropriate routing of the optical fiber slack and then have the rear connectors 252 attached to the appropriate structure for optical communication with the connection port passageways 233 of the multiport 200. The furcation body may also be secured to the connection port insert in the manner desired. By way of explanation, the input tether may be secured to shell 210 or connection port insert 230 using a collar that fits into a cradle. This attachment of the input tether using collar and cradle provides improved pull-out strength and aids in manufacturing; however, other constructions are possible for securing the input tether.

[00135] Generally speaking, the connection port passageways 233 may be configured for the specific connector 10 intended to be received in the connection port 236. Moreover, the connection port passageways 233 may be configured to provide a weatherproof seal with connector 10 or dust cap 295 for inhibiting dust, dirt, debris or moisture from entering the multiport 200 at a connection port passageway sealing surface 233SS (see FIG. 9). Likewise, the connection port passageways 233 should be configured for receiving the specific rear connector 252 from the rear portion 237 for mating and making an optical connection with the connector 10.

[00136] Regarding the different embodiments, the shell 210 or connection port insert 230 may be configured as a monolithic (e.g., integral) component for making the optical connection between the rear connectors 252 and the external connectors 10 of cable assembly 100; however, other embodiments are possible according to the concepts disclosed that use multiple components. In one variation, the multiports 200 may comprise a plurality of adapters 230A that are integrally-formed with the shell 210 or

connection port insert 230. In other variations, the shell 210 or connection port insert 230 may be configured to secure one or more adapters 230A thereto as separate components or assemblies. In either variation, the adapters 230A are aligned with the plurality of connection ports 236. Consequently, optical fibers of the connectors 10 are suitably aligned with the optical fibers 250 disposed within the multiport for optical communication therebetween.

[00137] Moreover, the adapters 230A may “float” relative to the shell 210 or connection port insert 230. “Float” means that the adapter 230A can have slight movement in the X-Y plane for alignment, and may be inhibited from over-traveling in the Z-direction along the axis of connector insertion so that suitable alignment may be made between mating connectors, which may include a biasing spring for allowing some displacement of the adapter 230A with a suitable restoring force provided by the spring.

[00138] Simply stated, the forces should be balanced between the both sides of these types of mated optical connections otherwise there may be concerns with one side of the mated connection over-traveling beyond its desired location, which may lead to optical performance issues especially if the connection experiences several matings and uses a floating ferrule sleeve for alignment. This over-travel condition typically is not of concern for mated connections where only side of the connection may be displaced and the other side is fixed. An example of both sides of the mated optical connection being able to be displaced occurs when both connectors have ferrules that are biased and mated within a ferrule sleeve such as when a SC connector is mated with a connector 10 as depicted in FIG. 9. Other embodiments could have an adapter sleeve that is biased instead of the rear connector ferrule being biased, which would result in a similar concern regarding forces that may result in over-travel conditions that could impact optical performance.

[00139] By way of explanation, multiports 200 that mate a rear connector 252 such as a SC with connector 10 that has a SC ferrule that is biased forward should have a spring force in connector 10 that mitigates concerns when mated within a ferrule sleeve or use a connector that has a fixed ferrule for mitigating concerns. The spring force for connector 10 should be selected to be in a range to overcome sleeve friction and the spring force of the rear connector 10. By way of explanation, when the rear connector 252 is first

inserted into the adapter 230A of connection port insert 230, the ferrule 252F of the rear connector 252 contacts the ferrule sleeve 230FS and may displace the ferrule sleeve 230FS to extreme position on the right before the ferrule sleeve 230FS hits a physical stop in the adapter and the ferrule 252F is inserted into the ferrule sleeve 230FS. Thus, when the connector 10 is later inserted into the connector port 236 of the multiport it would be helpful for the ferrule to push the ferrule sleeve 230FS from an extreme position in the adapter if it was displaced. Consequently, the spring selected for biasing the ferrule of connector 10 may be selected to overcome the sum of initial friction along with the insertion friction to move the ferrule sleeve 230FS, thereby inhibiting the ferrule sleeve 230FS from being displaced to a maximum position due to the rear connector 252 being inserted first.

[00140] The construction of multiport 200 of **FIG. 5** having securing feature 310 is discussed in more detail with respect to **FIGS. 8-11**, and similar details are applicable to multiports 200 using a connection insert 230 such as depicted in **FIGS. 4A and 4B**. **FIG. 8** depicts a longitudinal sectional view show securing feature 310 disposed within a portion of securing feature passageway 245 along with the rear connector 252 attached at the rear portion 237 of the connection port 236 of multiport 200 and **FIG. 9** depicts connector 10 of cable assembly 100 inserted into connection port 236 and retained by securing feature 310. **FIG. 8** depicts the connection port passageway 233 comprising a keying portion 233KP as discussed herein.

[00141] The rear connector 252 shown in **FIGS. 8 and 9** has a SC footprint, but other connectors are possible. If SC connectors are used as the rear connector 252 they have a keying feature 252K that cooperates with the keying feature of adapter 230A. Additionally, adapters 230A comprise a retention feature (not numbered) for seating the adapters 230A in the device adjacent to the connection port passageway 233. In this embodiment, the retention feature is configured to cooperate with a plurality of saddles 210D for receiving and seating adapters 230A. Adapters 230A may be secured to the shell 210A or connection port insert 230 using an adapter retainer 240. Adapters 230A may comprise latch arms for securing respective rear connectors therein. In other embodiments, adapters 230A may be ganged together or formed from several

components, but some adapters or portions thereof could be integrally formed with the multiport as well.

[00142] As shown in **FIG. 9**, the connector mating plane 230MP between the ferrule of the rear connector 252 and ferrule of connector 10 is disposed within the cavity 216 multiport 200 for protecting the connector mating interface. Connector 10 comprises at least one O-ring 65 for sealing with the connector port passageway 233 at a sealing surface 233SS when the connector 10 is fully inserted into the connection port 236. Moreover, connector 10 includes a locking feature 20L on the housing 20 for cooperating with a securing feature 310 of multiport 200.

[00143] Multiports 200 may also comprise a keying feature 236K that is disposed rearward of the securing feature 310 (i.e., deeper into the connection port passageway 233) for aligning and mating connector 10, for instance, connection port 236 or input connector port 260 may include a keyway or key such as shown in **FIGS. 10 and 11**. Keying feature 236K is disposed on the connector mating plane 230MP side of the securing feature 310.

[00144] Multiport may also have a keying portion 233KP disposed on the optical connector opening 238 side of the securing feature 310. Keying portion 233KP inhibits the insertion of a non-compliant connector into connection port 236, thereby inhibiting damage that may be caused to the device. Keying portion 233KP may be a protrusion or additive feature disposed within the connection port passageway 233 on the optical connector opening 238 side of the securing feature 310 and may take several different configuration if used. For instance, keying portion 233KP may be a simple protrusion or may take the shape of a D-shaped opening to allow only a suitable connector 10 having a complimentary feature to be inserted into the connection port 236. The keying portion 233KP may also aid with blind mating a connector 10 into the connection port 236 since it only allows further insertion into the connection port 236 when the connector is in the proper rotational orientation.

[00145] As best shown in **FIGS. 8 and 9**, multiport 200 of **FIG. 5** comprises at least one securing feature resilient member 310R for biasing the at least one securing feature 310. **FIGS. 12-14** show various perspective detailed views of securing feature 310. In this embodiment, securing features 310 may translate in a vertical direction as

represented by the arrow in **FIG. 8** for retaining and releasing connector 10 and acts as an actuator. As depicted, the resilient member 310R is disposed below the securing feature 310 in the securing feature passageway 245 for biasing the securing feature 310 upwards to a normally retained position (RP). Securing feature 310 further includes a locking feature 310L. Locking feature 310L is configured for engaging with a suitable locking portion 20L on the housing 20 of connector 10.

[00146] In this embodiment, securing feature 310 comprise a bore 310B that is respectively aligned with the respective connector port passageway 233 as shown in **FIG. 8** when assembled. The bore 310B is sized for receiving a portion of connector 10 therethrough as shown in **FIG. 9**. As depicted in this embodiment, locking feature 310L is disposed within bore 310B. As best shown in **FIGS. 12 and 13**, locking feature 310L is configured as ramp 310RP that runs to a short flat portion, then to a ledge that reverts to a round cross-section for creating the retention surface 310RS for engaging and retaining the connector 10 once it is fully-inserted into the connector port passageway 233 of the connection port 236. Consequently, the securing feature 310 is capable of moving to an open position (OP) when inserting a suitable connector 10 into the connector port passageway 233 since the connector housing 20 engages the ramp 310RP pushing the securing feature downward during insertion.

[00147] The securing feature 310 translates from a retain position (RP) to an open position (OP) as a suitable connector 10 is inserted into the connection port 236. Once connector 10 is fully inserted into connector passageway 233, then the securing feature 310 automatically moves to the retain position (RP) since it is biased upwards to the retain position. This advantageously allows a plug and play connectivity of the connectors 10 with multiport 200 without having to turn a coupling nut or a bayonet like conventional multiports. Thus, connections to the multiport may be made faster and in positions that may be awkward with relative ease.

[00148] Securing feature 310 may also comprise other features as best depicted in **FIGS. 12-14**. For instance, securing feature 310 may include a sealing member 310S disposed above the connector port passageway 233 for keeping dirt, debris and the like out of portions of the multiport 200. Sealing member 310S is sized for the retention

groove 310RG in the securing feature 310 and the securing feature passageway 245 for sealing.

[00149] Sealing member 310 may also comprises one or more guides 310G that cooperate with the shell 210 or connection port insert 230 for keeping the bore 310B in the proper rotational orientation within the respective securing feature passageway 245 during translation. In this embodiment, two guides 310G are arranged about 180 degrees apart and guide the translation of the securing feature 310. Securing feature 310 may also comprise one or more keys 310K that cooperate with the shell 210 or connection port insert 230 for only allowing one assembly orientation into the shell 210 or connection port insert 230, thereby keeping the locking feature 310L in the proper position within the respective securing feature passageway 245 with respect to the connector insertion direction.

[00150] Securing feature 310 may also comprise a stop surface 310SS for inhibiting overtravel or the securing feature 310 from being removed from the multiport 200 when assembled. In this embodiment, the stop surface 310SS is disposed as the top surface of guides 310G. Securing feature 310 may also include a dimple 310G or other feature for inhibiting inadvertent activation/translation of the securing feature 310 or allowing a tactical feel for the user. Securing features 310 may also be a different color or have a marking indicia for identifying the port type. For instance, the securing features 310 may be colored red for connection ports 236 and the securing feature 310 for the input connection port 260 may be colored black. Other color or marking indicia schemes may be used for pass-through ports, multi-fiber ports or ports for split signals.

[00151] The rear connector 252 shown in **FIGS. 8 and 9** has a SC footprint. The SC connectors used as the rear connector 252 has a keying feature 252K that cooperates with the keying feature of adapter 230A. Additionally, adapters 230A comprise a retention feature 233A disposed in the connection port passageway 233 and are configured as latch arms for securing a SC connector at the rear portion 237 of connection port insert 230.

[00152] Multiports may also have one or more dust caps (**FIG. 7**) for protecting the connection port 236 or input connection ports 260 from dust, dirt or debris entering the multiport or interfering with the optical performance. Thus, when the user wishes to make an optical connection to the multiport, the appropriate dust cap is removed and then

connector 10 of cable assembly 100 may be inserted into the respective connection port 236 for making an optical connection to the multiport 200. Dust caps 295 may use similar release and retain features as the connectors 10. By way of explanation, when securing feature 310 is pushed inward or down, the dust cap 295 is released and may be removed. Dust caps 295 may be attached to a rail 295R by a tether 295T or singulated as desired. The rail 295R is configured to engage a groove 230DR formed in shell 210 or the connection port insert 230. Consequently, the dust caps 295 of the multiport 200 are tethered to the multiport 200 so the dust caps 295 will not be lost as easily.

[00153] FIG. 15 depicts shell 210 of multiport 200 of FIG. 5 and FIGS. 16-18 depict various views of the first portion 210A of shell 210 of FIG. 5. Shells 210 may have any suitable shape, design or configuration as desired. For instance, the shell 210 of multiport 200 shown in FIG. 15, may include a second end 213 comprising one or more connection ports, pass-through ports, or the like as desired. Further, shells 210 may comprise more than two portions if desired. Likewise, multiple portions of the shell 210 may comprise connection ports 236.

[00154] Any of the multiports 200 disclosed herein may optionally be weatherproof by appropriately sealing seams of the shell 210 or the connection port insert(s) 230 with the shell 210 using any suitable means such as gaskets, O-rings, adhesive, sealant, welding, overmolding or the like. Moreover, the interface between the connection ports 236 and the dust cap or connector 10 may be sealed using appropriate geometry and/or a sealing element such as an O-ring or gasket. Likewise, the input connection port may be weatherproofed in a suitable manner depending on the configuration such as a gasket, or O-ring with an optical connection or a heat shrink, adhesive or the like when using a input tether. If the multiport 200 is intended for indoor applications, then the weatherproofing may not be required.

[00155] Multiport 200 may comprise integrated mounting features. By way of example, shell 210 depicts mounting features 210MF disposed near first and second ends 212,214 of shell 210. Mounting feature 210MF adjacent the first end 212 is a mounting tab and the mounting feature 210MF adjacent the second end 214 is a through hole. However, mounting features 210MF may be disposed at any suitable location on the shell 210 or connection port insert 230. For instance, multiport 200 also depicts a plurality of

mounting features 210MF configured as passageways disposed on the lateral sides. Thus, the user may simply use a fastener such as a zip-tie threaded thru these lateral passageways for mounting the multiport 200 to a wall or pole as desired.

[00156] Multiport 200 may have the input connection port 260 disposed in any suitable location. By way of explanation, multiport 200 may have the input connection port 260 disposed in an outboard position of the connection port insert 230. However, the input connection port 260 may be disposed in a medial portion of the multiport if desired.

[00157] Additionally, shells 210 may comprise at least one support 210S or fiber guide 210G disposed within cavity 216, thereby providing crush support for the multiport and resulting in a robust structure. As best depicted in **FIG. 17**, one or more of securing feature passageways 245 are arranged transversely to a longitudinal axis LA of the multiport 200 or shell 210. Multiport may include a fiber tray or fiber guide/supports that is a discrete component that may attach to the shell 210 or connector port insert 230; however, fiber guides may be integrated with the shell if desired. **FIG. 17** shows shell 210 comprise fiber guides 210G for organizing and routing optical fibers 250. Fiber guides 210G may also act as support 210S for providing crush strength to the shell 210 if they have a suitable length.

[00158] **FIGS. 19-26** depict the assembly of multiport 200 of **FIG. 5**. **FIGS. 19-26** depict the assembly of the multiport 200 of **FIG. 5**. **FIG. 19** depicts the securing feature 310 being aligned for installation into the securing feature passageway 245 of the first portion 210A of shell 210. As depicted, keying features 310K of securing feature 310 are aligned with the features of the securing feature passageway 245, which only allow assembly in one orientation for the correct orientation of the locking feature 310L. **FIG. 20** shows adapter 230A being aligned for installed into the saddle 210D of first portion 210A of shell 210. Once seated, the resilient member 230RM of adapter 230A is abutted against the rear ledge 210RL of saddle 210D, thereby compressing the resilient member 230RM and providing a suitable forward-biasing force to the adapter 230A as shown in **FIG. 21**. Once all of the adapters 230A are installed into first portion 210A, retainer 240 may be secured to first portion 210A for securing the adapters 230A in place as depicted

in **FIG. 22**. Retainer 240 may include securing features 240A for a robust assembly, but fasteners or other suitable structure may be used to attach the retainer 240

[00159] The devices disclosed may use any suitable rear connector 252 for making an optical connection at the connection port 236. Illustratively, **FIG. 23** depicts rear connector 252 comprising a ferrule 252F for securing and mating one or more optical fibers 250 aligned with adapter 230A along with other components before being assembled. Rear connector 252 is a SC connector as known in the art, but any suitable device having a ferrule or other structure for receiving and aligning one or more optical fibers 250 from inside the multiport is possible. **FIG. 23A** is an assembled sectional view showing the rear connector 252 attached to the adapter 230A with the ferrule sleeve retainer 230R and the ferrule sleeve 230FS installed for aligning mating ferrules.

[00160] Resilient member 230RM is disposed over a barrel of adapter 230A and seated on the flange of adapter 230A as depicted. Then, ferrule sleeve retainer 230R and ferrule sleeve 230FS are aligned and disposed between connector 252 the adapter 230A for assembly as shown in **FIG. 23**. In this embodiment, adapter 230A comprises a plurality of resilient arms 230RA comprising securing features 230SF. Securing features 230SF cooperate with protrusions on the housing of rear connector 252 for retaining the rear connector 252 to the adapter 230A with the ferrule sleeve retainer 230R and ferrule sleeve 230FS therebetween. **FIG. 23A** is a sectional view showing the attachment of the rear connector 252 with the adapter 230A with ferrule sleeve retainer 230R and the ferrule sleeve 230FS therebetween. Ferrule sleeves 230FS are used for precision alignment of mating ferrules between rear connectors 252 and connector 10. **FIG. 24** is a perspective view of the rear connector 252 with the ferrule sleeve retainer 230R and ferrule sleeve 230FS fitted over ferrule 252F before being attached to adapter 230A.

[00161] **FIGS. 24A-24I** depict alternative rear connectors that may be used with devices disclosed herein. **FIGS. 24A-24D** depict various views of a simplified construction for the rear connector 252 for use with adapter 230A. **FIGS. 24A-24D** show a simple ferrule 252F comprising protrusions 252P that cooperate with securing features 230SF disposed on the resilient arms 230RA of adapter 230A for securing the same. The ferrule sleeve 230FS is disposed between ferrule 252F and the adapter 230A as shown. **FIGS. 24E and 24F** show rear connector 252 having a ferrule 252F such as an SC

connector that cooperates directly with a portion of the multiport such as a shell for securing the same. In this embodiment, the rear connector 252 is inserted into a portion of the multiport and the ferrule for alignment without a separate adapter. The ferrule sleeve 230FS is disposed between rear connector 252 and the multiport structure as shown. As best shown in **FIG. 24I**, a portion of the rear connector 252 is secured in a multiport saddle 210D and secured between the first portion 210A and the second portion 210B of shell 210 in this embodiment. As shown, the connection port passageway 233 comprises keying portion 233KP.

[00162] **FIGS. 24G-24I** depict rear connector 252 having a ferrule 252F and a ferrule socket 252FS that holds and aligns the ferrule 252F. This rear connector cooperates directly with a portion of the multiport such as a shell for securing the same. In this case, the ferrule socket 252FS has one or more tabs (not numbered) that fit into a portion of the multiport such as a first portion 210A of shell 210. The ferrule socket 252FS is secured in a multiport saddle 210D. As best shown in **FIG. 24I**, the ferrule socket 252FS is secured between the first portion 210A and the second portion 210B of shell 210.

[00163] **FIG. 25** is a longitudinal cross-sectional view of a rear portion of the connection port 236 of the multiport 200 of **FIG. 5** with the rear connector 252 of **FIG. 24** attached to the adapter 230A. **FIG. 26** is a partial assembled view of multiport 200 of **FIG. 25** showing the respective securing feature resilient members 310R placed on a bottom portion of securing feature 310 within the first portion 210A of the shell 210 before the second portion 210B of shell 210 is attached to trap the securing feature resilient members 310R in place. Securing feature 310 may have a bottom recess 310BR for seating the securing feature resilient members 310R and centering the restoring force on the securing feature 310 as best shown in **FIG. 14**. Thereafter, the second portion 210B of shell 210 may be attached to the first portion 210A in a suitable fashion using a sealing element 290 or not.

[00164] Multiports 200 disclosed with shells 210 and/or connector port inserts 230 allow relatively small multiports 200 having a relatively high-density of connections along with an organized arrangement for connectors 10 attached to the multiports 200. Shells have a given height H, width W and length L that define a volume for the multiport as depicted in **FIG. 3A and 4A**. By way of example, shells 210 of multiport

200 may define a volume of 800 cubic centimeters or less, other embodiments of shells 210 may define the volume of 400 cubic centimeters or less, other embodiments of shells 210 may define the volume of 100 cubic centimeters or less as desired. Some embodiments of multiports 200 comprise a connection port insert 230 having a port width density of at least one connection port 236 per 20 millimeters of width W of the multiport 200. Other port width densities are possible such as 15 millimeters of width W of the multiport. Likewise, embodiments of multiports 200 may comprise a given density per volume of the shell 210 as desired.

[00165] The concepts disclosed allow relatively small form-factors for multiports as shown in Table 1. Table 1 below compares representative dimensions, volumes, and normalized volume ratios with respect to the prior art of the shells (i.e., the housings) for multiports having 4, 8 and 12 ports as examples of how compact the multiports of the present application are with respect to convention prior art multiports. Specifically, Table 1 compares examples of the conventional prior art multiports such as depicted in FIG. 1 with multiports having a linear array of ports. As depicted, the respective volumes of the conventional prior art multiports of FIG. 1 with the same port count are on the order of ten times larger than multiports with the same port count as disclosed herein. By way of example and not limitation, the multiport may define a volume of 400 cubic centimeters or less for 12-ports, or even if double the size could define a volume of 800 cubic centimeters or less for 12-ports. Multiports with smaller port counts such as 4-ports could be even smaller such as the shell or multiport defining a volume of 200 cubic centimeters or less for 4-ports, or even if double the size could define a volume of 200 cubic centimeters or less for 4-ports. Devices with sizes that are different will have different volumes from the explanatory examples in Table 1, and these other variations are within the scope of the disclosure. Consequently, it is apparent the size (e.g., volume) of multiports of the present application are much smaller than the conventional prior art multiports of FIG.1. In addition to being significantly smaller, the multiports of the present application do not have the issues of the conventional prior art multiports depicted in FIG. 2. Of course, the examples of Table 1 are for comparison purposes and other sizes and variations of multiports may use the concepts disclosed herein as desired.

[00166] One of the reasons that the size of the multiports may be reduced in size with the concepts disclosed herein is that the connectors 10 that cooperate with the multiports have locking features 20L that are integrated into the housing 20 of the connectors. In other words, the locking features for securing connector 10 are integrally formed in the housing 20 of the connector, instead of being a distinct and separate component like a coupling nut of a conventional hardened connector used with conventional multiports. Conventional connectors for multiports have threaded connections that require finger access for connection and disconnecting. By eliminating the threaded coupling nut (which is a separate component that must rotate about the connector) the spacing between conventional connectors may be reduced. Also eliminating the dedicated coupling nut from the conventional connectors also allows the footprint of the connectors to be smaller, which also aids in reducing the size of the multiports disclosed herein.

Multiport Type	Port Count	Dimension LxWxH (mm)	Volume (cm ³)	Normalized Volume Ratio
Prior Art FIG. 1	4	274 x 66 x 73	1320	1.0
	8	312 x 76 x 86	2039	1.0
	12	381 x 101 x 147	5657	1.0
Linear	4	76 x 59 x 30	134	0.10
	8	123 x 109 x 30	402	0.20
	12	159 x 159 x 30	758	0.14

Table 1: Comparison of Conventional Multiport of FIG. 1 with Multiports of Present Application

[00167] Devices may have other constructions for the securing features 310 that use more than one component. FIGS. 27 and 28 depict perspective views of another explanatory device 200 configured as a multiport that comprises at least one connection port 236 along with a securing feature 310 comprising more than one component. Multiports 200 with securing features having more than one component such as shown in FIGS. 27 and 28 may have a construction similar to that shown in FIGS. 3A and 3B with the connection ports 236 being a portion of the connection port insert 230 or a

construction similar to that shown in **FIGS. 4A and 4B** with the connection ports 236 as a portion of shell 210 as desired.

[00168] Illustratively, **FIGS. 28A-28E** depict a device such as multiport 200 that comprises connection port insert 230 having at least one connection port 236 and **FIGS. 29-56** depict device such as multiport 200 comprising a connection port 236 as a portion of the shell 210 with securing features 310 comprising more than one component. The description of these devices with the securing feature 310 comprising more than one component will describe differences in the designs for the sake of brevity.

[00169] Multiports 200 of **FIGS. 27 and 28** comprise one or more optical connection ports 236 defined by one or more optical connector openings 238 disposed in a shell 210 of the multiport 200 for receiving one or more connectors 10 according to the concepts disclosed. **FIG. 27** depicts a connector 10 aligned for insertion into one of the connection ports 236 and **FIG. 28** depicts a plurality of connectors 10 retained within respective connection ports 236. Multiport 200 using securing features 310 comprising multiple components may also comprise an input port 260, splitter, tether, or other suitable components or features as desired.

[00170] Multiport 200 of **FIGS. 27 and 28** is similar to multiport 200 of **FIGS. 4A and 4B**, except it uses a securing feature 310 comprising more than one component as shown in **FIG. 36**. Likewise, the multiport 200 of **FIGS. 28A-28E** is similar to multiport 200 of **FIGS. 3A and 4B**, except it uses a securing feature 310 comprising more than one component as best shown in **FIG. 28D**. In these embodiments, the securing feature 310 comprises an actuator 310A and a securing feature member 310M. Specifically, securing feature member 310M comprises an opening may be elastically deformed by actuator 310A (or other structure) when pushed (or upon insertion of a suitable connector 10 into connection port 236) and the securing feature member 310M springs back to engage a suitable portion of connector 10 such as locking feature 20L of connector housing 20 when the actuator 310A is released or when connector 10 is fully-seated within the connection port 236 as will be discussed in more detail. The securing member 310M comprises a locking feature 310L formed by one or more arms 310AM.

[00171] Thus, the securing feature member 310M of securing feature 310 is suitable for retaining connector 10 in connection port 236 as discussed herein. Various different

embodiments are possible for securing features 310 comprising more than one component for the devices disclosed.

[00172] Multiport 200 of **FIGS. 27 and 28** comprise one or more connection ports 236 and the one or more securing feature passageways 245 as a portion of the shell 210. Likewise, multiports 200 of **FIGS. 28A-28E** comprises the one or more connection ports 236 and the one or more securing feature passageways 245 as a portion of the connection port insert 230 as discussed hererin.

[00173] Illustratively, **FIGS. 27 and 28** depict multiport 200 comprising a shell 210 comprising a body 232 with one or more connection ports 236 disposed on a first end or portion 212 with each connection port 236 comprising a respective optical connector opening 238. The optical connector openings 238 extend from an outer surface 234 of shell 210 into a cavity 216 and define a connection port passageway 233. One or more respective securing feature passageways 245 extend from the outer surface 234 of the shell 210 to the respective connection port passageways 233. A plurality of security features 310 are associated with the respective plurality of connection port passageways 233 and the plurality of securing features 310 are disposed within portions of respective securing feature passageways 245.

[00174] **FIGS. 28A-28E** are views another multiport 200 comprising connection port insert 230 that receives an actuator 310A and a securing feature member 310M of the securing feature 310 similar to multiport 200 of **FIGS. 27 and 28**. As best shown in **FIGS. 28D and 28E**, this embodiment is different in the manner which the securing feature 310M is assembled to the connection port insert 230 from a rear side and secured with a securing feature locking member 310LM at the bottom of the securing feature member 310M. In this embodiment, the securing feature members 310M are individually placed into the connection port insert 230 from the rear and engage a portion of the actuator 310A for keeping the actuators 310A within the respective securing feature passageways 245. The securing feature 310 of this embodiment further includes a securing feature resilient member 310R for biasing the actuator 310A. In this embodiment, the fiber tray 285 may be used as a retainer for securing the adapters 230A as well.

[00175] **FIG. 29** depicts a bottom perspective view of multiport 200 of **FIGS. 27 and 28**. As depicted, shell 210 is formed by a first portion 210A and a second portion 210B. **FIG. 29** shows the second portion 210B of shell 210 removed from the first portion 210A for showing the internal construction of multiport 200. Multiport 200 is depicted with the rear connectors 252 and the optical fibers 250 removed for clarity purposes in **FIG. 29**.

[00176] **FIG. 30** is a partially exploded view of the multiport of **FIGS. 27 and 28** showing a single rear connector 252 and having the optical fibers 250 removed for clarity. Rear connectors 252 are aligned and sized for fitting into one or more of the respective connector port passageways 233 from the rear portion 237 of passageway 233 within the cavity 216 of shell 210, and the plurality of rear connectors 252 are associated with one or more of the plurality of optical fibers 250. As discussed, each of the respective rear connector 252 aligns and attaches to the shell 210 from the rear portion 237 in a suitable matter. However, rear connectors 252 may take any suitable form from a simple ferrule that attaches to standard connector type inserted into an adapter.

[00177] **FIGS. 31 and 32** are partial longitudinal cross-sectional views respectively depicting the optical connection port 236 of the multiport 200 of **FIGS. 27 and 28** without connector 10 retained therein for showing details of securing feature 310. **FIG. 33** is a longitudinal cross-sectional views of the multiport 200 of **FIGS. 27 and 28** with connector 10 disposed and retained within connection port 236 by securing feature 310. As shown, the connection port passageway 233 comprises keying portion 233KP disposed forward of the securing feature 310 in connection port passageway 233.

[00178] **FIG. 34** is a transverse cross-sectional view of a portion of the multiport 200 of **FIGS. 27 and 28** taken through the securing features 310 showing details of the construction and operation for securing features 310 comprising more than one component. **FIGS. 35** is a detailed longitudinal horizontal cross-sectional view of the securing feature 310 receiving and retaining connector 10 within the connection port 236. Specifically, the arms of the securing member 310M engage a locking feature 20L (e.g., a groove) that is integrally-formed on the housing 20 of the connector 10. **FIG. 36** is a detailed perspective view of the securing features of the multiport of **FIGS. 27 and 28** removed from the shell with connector 10 being retained by one of the securing features 310.

[00179] Securing feature 310 comprises actuator 310A and securing member 310M. Securing member 310M comprises an opening between its arms 310AM that may be elastically deformed by actuator 310A when translated (i.e., pushed) or upon insertion of a suitable connector 10 into connection port 236 by spreading (i.e., translating) the arms of the securing member 310M outward. When the actuator 310A is released or the connector is fully-seated within the connection port 236 or input port 260, the arms 310AM of the securing member 310M springs back to engage a suitable portion of connector 10 such as locking feature 20L of connector housing 20 or move the actuator 310A to a normal position. The arms 310AM have an edge portion that act as a locking feature 310L for the suitable connector 10. By way of explanation, the edge portions of arms 310AM engage the locking feature 20L of the connector housing 20 for securing the connector 20. In order to release the connector 10 from the connection port 236, the arms 310AM and locking features 310L on the arms 310AM are translated outward.

[00180] As best shown in FIG. 34, actuator 310A comprises a wedge 310W that pushes into a head end 310H of securing member 310M, thereby elastically deflecting the arms 310AM of securing member 310M outward for releasing connector 10. The securing member 310M or actuators 310A of securing feature 310 may comprise a variety of different constructions. Likewise, the securing features 310 comprising more than one component may be biased by a securing feature resilient member 310RM if desired. For instance, securing feature resilient member 310RM may bias the actuator 310A toward a secure position. In other embodiments, the securing feature resilient member may bias the securing member 310M.

[00181] FIGS. 37-39 are various perspective views of the actuator 310A of the securing feature 310 of the multiport 200 shown in FIGS. 27 and 28. Actuator 310A may include a sealing member 310S disposed above the connector port passageway 233 for keeping dirt, debris and the like out of portions of the multiport 200. Sealing member 310S is sized for the retention groove 310RG in the actuator 310A and the securing feature passageway 245 for sealing. Actuator 310A may also be shaped to have one or more guides 310G that cooperate with the shell 210 or connection port insert 230 for keeping proper rotational orientation of the wedge 310W within the respective securing feature passageway 245 during translation. In this embodiment, the shape of the flange

aids in the rotational orientation. Actuator 310A may also comprise a stop surface 310SS for inhibiting overtravel or the actuator 310A from being removed from the multiport 200 when assembled. Actuator 310A may also be a different color or have a marking indicia for identifying the port type. For instance, the actuator 310A may be colored red for connection ports 236 and the actuator 310A for the input connection port 260 may be colored black. Other color or marking indicia schemes may be used for pass-through ports, multi-fiber ports or ports for split signals.

[00182] FIGS. 40-43 are various views of securing member 310M for explaining details of the design. FIG. 40 is a perspective view of the securing member blank for forming the securing feature 310M depicted in FIGS. 41-43. Securing member 310M may be formed from any suitable material such as a spring steel and have a suitable geometry for retaining a connector 10. FIGS. 41-43 are various perspective views showing the structure of securing member 310M. As depicted, securing member 310M comprises arms 310AM that define an opening (not numbered) therebetween along with a head end 310H formed at the ends of the arms 310AM. The opening (not numbered) between the arms 310AM is sized for cooperating with a suitable connector 10. Arms 310AM may comprise tabs 310T that are curved for aiding the engagement of the connector 10 with the securing member 310M upon insertion and allowing a smoother pushing and translation of the arms 310AM outward as connector 10 is inserted into connection port 236. Likewise, the head end 310H may also be formed with a suitable shape that cooperates with the actuator 310A.

Like the other securing features 310, the securing feature 310 may comprises more than one component for translating from a retain position (RP) to an open position (OP) as a suitable connector 10 is inserted into the connection port 236. Once connector 10 is fully-inserted into connector passageway 233, then the securing feature 310 automatically moves to the retain position (RP) since the arms 310AM are biased to the retain position. This advantageously allows a push and play connectivity of the connectors 10 with multiport 200 without having to turn a coupling nut or a bayonet like conventional multiports. Thus, connections to the multiport may be made faster and in positions that may be awkward with relative ease.

[00183] The other components of the multiport 200 of **FIGS. 27 and 28** are shown and discussed as assembled in **FIGS. 44-56**. **FIGS. 44 and 45** are bottom and top perspective views showing the optical fiber tray or guide 285 that is placed into shell 210A of multiport 200. **FIG. 46** is a bottom perspective view of a first portion of the shell of the multiport 200 and **FIG. 47** is a perspective view of the second portion of the shell of the multiport of 200 for showing details.

[00184] **FIGS. 48 and 49** respectively are partially exploded and assembled views of a securing feature sub-assembly 310SA for a portion of the securing feature 310. As depicted, the securing members 310M may be placed into a housing formed by one or more housing portions 310HH for maintaining the proper orientation of the securing features. The securing feature sub-assembly 310SA also allows for easier assembly of multiple securing members 310M into the devices. Further, the housing portions 310HH may have suitable geometry for keeping the securing members in the desired orientation. **FIG. 49** depicts the securing feature sub-assembly 310SA ready for placing into the device. **FIG. 50** depicts the components of securing feature 310 being installed into the first portion of the shell of **FIG. 46**. As depicted, the actuators 310A of the securing features are installed into the respective securing feature passageways of the shell 210A with the wedge 310W facing up. Thereafter, the securing feature sub-assembly 310SA may be placed into a cavity 210C of the securing feature passageway formed within shell 210A. Consequently, the actuators 310A are aligned and positioned with respective securing members 310M of the securing features.

[00185] **FIGS. 51-52** show the optical fiber tray or guide 285 being installed into the first portion of the shell of the multiport 200. The devices may also comprises a fiber guide or tray (not numbered) integrated with the body 232. Fiber tray 285 may include one or more protrusions 285P that aid alignment and may also provide strength for the device to withstand any crushing forces. Including supports for multiports 200 greatly improves the strength between the opposing walls, and the supports may be included on other components such as the shell 210 such as 210P or the integrated in a separate fiber tray such as depicted. Supports or protrusions may also act as fiber routing guides to inhibit tight bending or tangling of the optical fibers and aid with slack storage of optical

fibers 250. Other embodiments may also comprises one or more fiber routing guides 230G or supports 230S.

[00186] **FIG. 53** is a perspective view of the adapters 230A and retainer 240 being aligned for installation into the first portion 210A of the shell 210 and **FIG. 54** is a perspective view of the plurality of adapters and an adapter retainer assembled into the first portion 210A of the shell 210. **FIG. 55** shows the second portion 210B of the shell 210 being aligned with the first portion 210A of the shell 210 with the rear connectors 252 and optical fibers 250 removed for clarity. **FIG. 56** is a detailed sectional view showing details of the interlocking features between the first portion 210A and the second portion 210B of the shell 210. Specifically, portions of the multiport may have a tongue 210T and groove 210G construction for alignment or sealing of the device.

[00187] Securing features 310 comprising more than one component may have various configurations for use with devices disclosed herein. **FIGS. 57-59** depict perspective views of another securing feature 310 comprising securing member 310M for use with an actuator 310A. **FIG. 60** depicts a suitable connector housing 20 for the securing member 310M of **FIGS. 57-59**. As shown, the connector housing 20 has the locking feature 20L disposed forward of the O-ring 65. **FIG. 57** is a perspective view of the securing member blank for forming the securing member 310M depicted in **FIGS. 58 and 59**. **FIG. 58** depicts securing member 310M comprising arms 310AM that define an opening (not numbered) therebetween along with a head end 310H formed at the ends of the arms 310AM. The opening (not numbered) between the arms 310AM is sized for cooperating with a suitable connector 10. The head end 310H of the arms 310AM have a tapered shape for cooperating with the actuator 310A to translate the arms 310AM outward when the acutator 310A translates downward as best shown in **FIG. 59**. **FIGS. 61 and 62** are perspective views of the securing feature 310 cooperating with the connector housing 20 of **FIG. 60**. As discussed and depicted, the securing member 310M may be secured in the device using locking member 310LM.

[00188] **FIGS. 63-65** depict perspective views of yet another securing member 310M for securing features 310 comprising more than one component along with a suitable connector housing 20 for cooperating with the securing feature 310. By way of example, **FIG. 63** shows securing member 310M formed from a wire. Like the other securing

members 310M, this securing member 310M comprises arms 310AM that define an opening (not numbered) therebetween along with a head end 310H formed at the ends of the arms 310AM. The opening (not numbered) between the arms 310AM is sized for cooperating with a suitable connector 10. When assembled, the head end 310H of the arms 310AM are received in a portion of actuator 310A as shown in **FIG. 65**. This securing feature 310 may also be biased by a resilient member 310R.

[00189] **FIGS. 66-68** depict perspective views of yet another securing feature comprising more than one component. In this embodiment, the securing member 310M is inverted so that the head end 310H cooperates with a portion of the multiport for translating the arms 310AM compared with other embodiments. More specifically, a portion of the multiport such as connector port insert of shell comprises a wedge 210W as shown in **FIG. 69**. **FIG. 66** depicts the actuator 310A attached to a base 310B of the securing member 310M and the head end 310H disposed on the opposite end and **FIG. 67** shows that the base 310B may have aperture for securing the actuator 310A to the securing member 310M. **FIG. 68** shows connector housing 20 cooperating with the arms 310AM for securing the connector 10. This securing feature 310 may also be biased by a resilient member 310R as shown. **FIG. 69** shows how the head end 310H of securing member 310M cooperates with wedge 210W of the multiport for translating the arms 310AM outward when the acutator 310A translates downward.

[00190] **FIGS. 70-72** depict views of yet another securing feature comprising more than one component. **FIG. 70** is a sectional view of another securing feature 310 comprising securing member 310M for use with an actuator 310A that provides a reduced height compared with other embodiments. This securing member 310M comprises arms 310AM that define an opening (not numbered) therebetween along with a head end 310H formed at the ends of the arms 310AM. Head end 310H of this securing member 310M has the ends curled in and downward and the actuator 310A positions the wedge 310W further upward into the acutator 310A footprint as shown in **FIG. 70** resulting in a construction that has a reduced height and allowing the device to reduce its height as well. **FIG. 71** depicts a suitable connector housing 20 for the securing member 310M with the actuator 310A translated to an open position for releasing the connector. Again, the connector housing 20 has the locking feature 20L disposed forward of the

groove for the O-ring 65. **FIG. 72** shows the notch 310N that allows the wedge 310W to be incorporated further into the body of the actuator 310A.

[00191] Securing features 310 may have any suitable orientation or construction for engaging connectors 10. **FIG. 73** is a sectional view of a further securing feature 310 arranged at an angle relative to the longitudinal axis LA of the connection port 236. As shown, This securing feature 310 comprises securing member 310M and actuator 310A disposed in a securing feature passageway 245 that is angled with respect to the longitudinal axis LA of the connection port 236. Likewise, connector 10 has a connector housing 20 with the locking feature 20L that is angled with respect to the longitudinal axis of the connector. Similar concepts may be used with as a portion of the shell or the connection port insert as well as a monolithic securing feature 310.

[00192] Other variations are also possible for securing features. **FIG. 74** depicts a device 200 comprising the actuator 310A of the securing feature 310 disposed in a horizontal direction with respect to the longitudinal axis LA of the connection port 236. **FIG. 74A** is a perspective views showing a securing feature construction without the multiport and securing connector 10. This securing feature 310 comprises actuator 310A and securing member 310M. This securing member 310 comprises bore 310B for receiving the connector 10 therethrough. Bore 310B may have any suitable locking feature 310L (not visible) for cooperating with connector 10. Securing member 310M comprises a securing member push 310P. Securing member push 310P is configured as a ramp for translating the securing member 310M as the actuator 310A is translated toward the securing member 310M. Actuator 310A comprises a complimentary surface that cooperates with securing member push 310P. Securing feature resilient member 310RM may bias the actuator. Consequently, the securing member 310M may translate from a secure position to an open position. This securing feature 310 may have other features as disclosed herein as well. **FIG. 74B** depicts the securing feature 310 of **FIG. 74A** being placed into the device.

[00193] **FIGS. 75-82** depict another device such as a multiport 200 similar to **FIG. 74** the actuator 310A of the securing feature 310 arranged in a direction that is generally aligned and offset from the longitudinal axis of the connector port 236. This multiport 200 of **FIGS. 75-82** is also similar to the embodiment of **FIGS. 27 and 28** and shown in

cross-section of the connection port 236 at **FIG. 33** since the securing members 310M are disposed in a sub-assembly 310SA. Since the actuator 310A is generally positioned horizontal with the connection port 236 the securing member 310M is modified for cooperating with the different translation direction of the actuator 310A.

[00194] Specifically, the wedge 310W of actuator 310A moves in a horizontal direction as depicted in **FIGS. 75 and 77** and the head end 310H moves to the optical connector opening 238 side of the securing member 310M. This embodiment shows the securing members 310M disposed in a securing feature sub-assembly 310SA that is positioned in a cavity 210C of the securing feature passageway 245 formed within shell 210A as shown in **FIG. 76**. **FIGS. 75 and 77** show that the connection port passageway 233 comprises keying portion 233KP disposed forward of the securing feature 310 in connection port passageway 233. **FIG. 78** depicts first portion 210A of shell 210 from the inside without components installed and **FIG. 79** depicts actuators 310A placed into a portion of the securing feature passageway 245 of first portion 210A of shell 210. Actuators 310A may have features as disclosed herein. **FIGS. 80 and 81** depict that this embodiment has the securing member housing 310HH is formed as a single component but may the securing member housing 310HH may be formed from multiple components if desired. **FIG. 82** depicts a perspective view of the securing member 310M for this embodiment. Arms 310AM may comprise tabs 310T that are curved for aiding the engagement of the connector 10 with the securing member 310M upon insertion and allowing a smoother pushing and translation of the arms 310AM outward as connector 10 is inserted into connection port 236. Likewise, the head end 310H may also be formed with a suitable shape that cooperates with the actuator 310A during translation.

[00195] Still other variations of the concepts disclosed are possible to increase the connector port density or count on devices. **FIG. 83** is a top view of another multiport 200 having connection ports 236 (or connection port passageways 238) associated with securing features that are disposed on both a first (or portion) end and a second (or portion) end of the device. This concept may be used with devices that use a connection port insert 230 or connection ports that are formed as a portion of the shell.

[00196] Other embodiments with multiple components comprising connection ports 236 and associated securing features 310 are also possible according to the concepts

disclosed. **FIGS. 84-88** are various views of another multiport 200 having connection ports 236 disposed in more than one row according to the concepts disclosed. This multiport 200 comprises twelve connection ports 236 and one input connection port 260 in a relatively dense arrangement and is advantageous for use where space is at a premium such as in a pedestal. This multiport 200 comprises shell 210 comprising two portions 210A,210A' with portion 210A comprising an input connection port 260. Both portions of shell 210 comprise connection ports 236 and features for securing features 310 as disclosed herein. The portions 210A,210A' of shell 210 comprise a construction similar to the construction of the multiport 200 of **FIGS. 27 and 28**, and which is shown partially exploded in **FIG. 30** so details of the construction will not be repeated for brevity. The portions 210A, 210A' of shell 210 are configured to be secured back-to-back so the open portions of the portions align, thereby forming a common cavity 216 between the portions 210A,210A' of shell 210.

[00197] Still other devices and embodiments having multiple components comprising connection ports 236 and associated securing features 310 are also possible according to the concepts disclosed. Illustratively, **FIGS. 89-91** are various views of multiport 200 comprising connection ports 236 disposed in stacked rows and laterally offset in a stair-step fashion. This multiport 200 also comprises twelve connection ports 236 and one input connection port 260 in a relatively dense arrangement. This multiport 200 has shell 210 comprising first portion 210A, second portion 210B', and third portion 210B. Although, the first portion 210A of shell comprises the input connection port 260, other portions could comprise an input connection port as well. Both portions 210A, 210B' of shell 210 comprise a connection ports 236 and features for securing features 310 as disclosed herein. First portion 210A and third portion 210B sandwich second portion 210B' of shell 210 therebetween. The portion 210B' of shell 210 has a cavity that is open to both first shell 210A and third shell 210B. Fiber tray 285 may be used to arrange optical fibers 250 on both sides for aiding assembly and simplicity. The portions 210A,210B' of shell 210 comprise a construction similar to the construction of the multiport 200 of **FIGS. 27 and 28** for the securing features 310 and connection ports 236 so details of the construction will not be repeated again for the sake of brevity.

[00198] **FIGS. 92-96** are various views of still another device having connection ports 236 disposed in stacked rows that are offset and arranged on an angled surface in a stair-step fashion similar to the device of **FIGS. 89-91**. This multiport 200 also comprises twelve connection ports 236 and one input connection port 260 in a relatively dense arrangement. This multiport 200 has shell 210 comprising first portion 210A, second portion 210B', and third portion 210B similar to the shell of **FIGS. 89-91**. In this embodiment, first portion 210A and second portion 210B' arrange the connection ports 236 on an angled surface. First portion 210A and third portion 210B sandwich second portion 210B' of shell 210 therebetween. The portion 210B' of shell 210 has a cavity that is open to both first shell 210A and third shell 210B as shown in **FIG. 93**. **FIGS. 94-96** depict perspective views of the first portion 210A and the second portion 210B' of shell 210. The portions 210A,210B' of shell 210 comprise a construction similar to the construction of the multiport 200 of **FIGS. 27 and 28** for the securing features 310 and connection ports 236 so details of the construction will not be repeated again for the sake of brevity.

[00199] Devices may include other components such as protectors or covers 200C for security purposes or keeping dirt, debris and other contaminants away from securing features 310. For instance, the service provider may desire a security cover for deterring tampering with the multiport 200. Covers may use security fasteners, a locking device that requires a security key, or other means for securing the cover. **FIGS. 97 and 98** are perspective views of a first cover 200C that may be used with multiports 200. This cover 200C cooperates with mounting features 210MF formed on multiport 200. Specifically, arms (not numbered) of cover 200C engage the respective mounting features 210MF disposed on the multiport as shown in **FIG. 97**. **FIG. 98** shows that cover 200C essentially hides the securing features 310 when installed. Cover 200C may be secured in any suitable fashion.

[00200] Other cover variations are also possible for multiports 200. **FIGS. 99-101** are perspective views of a second cover 200C that cooperates with a bracket 200B that may be used multiports 200. This cover 200C cooperates with bracket 200B as shown in **FIG. 99**. **FIG. 98** shows bracket 200B and when cover 200C is attached to bracket 200B its

essentially hides the securing features 310. **FIG. 101** shows the features on the inside portion of cover 200C that cooperate with the bracket 200B for securing the same.

[00201] **FIG. 102** is a perspective view of a wireless device 500 having a similar construction to the concepts disclosed herein and comprising at least one connector port 236 associated with securing member 310. Wireless device 500 may comprise one or more connection ports 236 disposed on connection port insert as represented by parting line PL1 or one or more connection ports 236 disposed on the portion of shell 210 as represented by parting line 2. Wireless device 500 may have an input port that includes power and may have electronics 500E (not visible) disposed with in the cavity (not visible) of the device.

[00202] Still other devices are possible according to the concepts disclosed. **FIG. 103** is a perspective view of a closure 700 comprising at least one connector port 236 and associated securing member 310. Like wireless device 500, closure 700 may comprise one or more connection ports 236 disposed on connection port insert as represented by parting line PL1 or one or more connection ports 236 disposed on the portion of shell 210 as represented by parting line 2. Closure 700 may have one or more input ports or include other components disposed with in the cavity (not visible) of the device.

[00203] The present application also discloses methods for making a device. One method comprises inserting a connection port insert 230 into an opening 214 disposed in a first end 212 of an shell 210 so that at least a portion of the connection port insert 230 fits into the opening 212 and is disposed within a cavity 216 of the shell 210; and wherein the connection port insert 230 comprises a body 232 having a front face 234 and at least one connection ports 236 with the connection port 236 having an optical connector opening 238 extending from the front face 234 into the connection port insert 230 with a connection port passageway 233 extending through part of the connection port insert to a rear portion 237.

[00204] Other methods for making devices such as multiports 200 as disclosed herein are also contemplated. One method comprises routing a plurality of optical fibers 250 from one or more rear portions 237 of a plurality of connection ports 236 of a connection port insert 230 so that the plurality of optical fibers 250 are available for optical communication at an input connection port 260 of the connection port insert 230. Then

inserting the connection port insert 230 into an opening 214 disposed in a first end 212 of a shell 210 so that at least a portion of the connection port insert 230 fits into the opening 212 and is disposed within a cavity 216 of the shell 210; and wherein the connection port insert 230 comprises a body 232 having a front face 234 and a plurality of connection ports 236 with each connector port 236 having an optical connector opening 238 extending from the front face 234 into the connection port insert 230 with a connection port passageway 233 extending through part of the connection port insert to the rear portion 237.

[00205] The methods disclosed may further include installing at least one securing feature 310 into a multiport 200 so that the at least one securing feature 310 is associated with connection port 236. The securing feature 310 may translate between an open position OP and a closed position CP. The method may include translating the securing feature 310 for moving the securing feature 310 to the open position OP and the securing feature 310 is biased to closed position CP.

[00206] Although the disclosure has been illustrated and described herein with reference to explanatory embodiments and specific examples thereof, it will be readily apparent to those of ordinary skill in the art that other embodiments and examples can perform similar functions and/or achieve like results. For instance, the connection port insert may be configured as individual sleeves that are inserted into a passageway of a device, thereby allowing the selection of different configurations of connector ports for a device to tailor the device to the desired external connector. All such equivalent embodiments and examples are within the spirit and scope of the disclosure and are intended to be covered by the appended claims. It will also be apparent to those skilled in the art that various modifications and variations can be made to the concepts disclosed without departing from the spirit and scope of the same. Thus, it is intended that the present application cover the modifications and variations provided they come within the scope of the appended claims and their equivalents.

We claim:

1. A multiport (200) for making an optical connection, comprising:
 - a shell (210);
 - at least one connection port (236) disposed on the multiport (200) with the at least one connection port (236) comprising an optical connector opening (238) extending from an outer surface (234) of the multiport (200) into a cavity (216) of the multiport (200) and defining a connection port passageway (233), the connection port passageway (233) comprising a keying portion (233KP);
 - at least one securing feature passageway (245); and
 - at least one securing feature (310) associated with the connection port passageway (233), wherein the at least one securing feature is disposed within a portion of the at least one securing feature passageway (245).

2. The multiport of claim 2, further comprising at least one securing feature resilient member (310RM) for biasing a portion of the at least one securing feature (310).

3. A multiport (200) for making an optical connection, comprising:
 - a shell (210);
 - at least one connection port (236) disposed on the multiport (200) with the at least one connection port (236) comprising an optical connector opening (238) extending from an outer surface (234) of the multiport (200) into a cavity (216) of the multiport (200) and defining a connection port passageway (233), the connection port passageway (233) comprising a keying portion (233KP);
 - at least one securing feature passageway (245);
 - at least one securing feature (310) associated with the connection port passageway (233), wherein the at least one securing feature is disposed within a portion of the at least one securing feature passageway (245); and
 - at least one securing feature resilient member (310R) for biasing a portion of the at least one securing feature (310).

4. The multiports of any one of claims 1-3, wherein the at least one securing feature is capable of translating within a portion of the at least one securing feature passageway (245).

5. The multiport of claims 3 or 4, wherein of the at least one securing feature (310) is biased to a retain position (RP).

6. A multiport (200) for making optical connections, comprising:
a shell (210);

at least one connection port (236) comprising an optical connector opening (238) extending from an outer surface (234) of the multiport (200) into a cavity (216) and defining a connection port passageway (233), the connection port passageway (233) comprising a keying portion (233KP);

at least one securing feature passageway (245);

at least one securing feature (310) associated with the at least one connection port passageway (233), wherein the at least one securing feature is disposed within a portion of the securing feature passageway (245), and the at least one securing feature (310) is capable of translating within a portion of the at least one securing feature passageway (245).

7. The multiport of any of claims of 1-6, wherein the at least one securing feature (310) comprises a bore 310B that is aligned with the at least one connection port passageway (233).

8. A multiport (200) for making optical connections, comprising:
a shell (210);

at least one connection port (236) comprising an optical connector opening (238) extending from an outer surface (234) of the multiport (200) into a cavity (216) and defining a connection port passageway (233), the connection port passageway (233) comprising a keying portion (233KP);

at least one securing feature passageway (245);

at least one securing feature (310) associated with the at least one connection port passageway (233), and the at least one securing feature (310) comprises a bore (310B), wherein the at least one securing feature is disposed within a portion of the securing feature passageway (245), and the at least one securing feature (310) is capable of translating within a portion of the at least one securing feature passageway (245).

9. The multiport of any one of claims 1-8, wherein the at least one securing feature (310) translates from a retain position (RP) to an open position (OP) as a suitable fiber optic connector (10) is inserted into the at least one connection port (236).

10. The multiport of any one of claims 1-9, wherein the at least one securing feature (310) is capable of releasing a fiber optic connector when translating within a portion of the at least one securing feature passageway (245).

11. The multiport of any one of claims 1-10, wherein the at least one securing feature (310) is capable of moving to a retain position (RP) automatically when a suitable fiber optic connector is fully-inserted into the at least one connector port passageway (233).

12. The multiport of any one of claims 1-11, wherein the at least one securing feature (310) comprise a locking feature (310L).

13. The multiport of any one of claims 1-11, wherein the securing feature (310) comprise a locking member (310M) and an actuator (310A)

14. A multiport (200) for making optical connections, comprising:
a shell (210);
at least one connection port (236) comprising an optical connector opening (238) extending from an outer surface (234) of the multiport (200) into a cavity (216) and defining a connection port passageway (233), the connection port passageway (233) comprising a keying portion (233KP);
a securing feature passageway (245);

at least one securing feature (310) associated with the at least one connection port passageway (233), and the at least one securing feature (310) comprises a bore (310B), wherein the at least one securing feature is disposed within a portion of the securing feature passageway (245), and the at least one securing feature (310) is capable of translating within a portion of the at least one securing feature passageway (245) wherein the at least one securing feature (310) translates from a retain position (RP) to an open position (OP) as a suitable fiber optic connector (10) is inserted into the at least one connection port (236).

15. The multiport of claim 14, wherein the bore (310B) is sized for receiving a suitable fiber optic connector therethrough.

16. The multiport of claims 14 or 15, wherein the bore (310B) comprises a locking feature (310L).

17. The multiport of any one of claims 5-16, further comprising at least one securing feature resilient member (310R) for biasing a portion of the at least one securing feature (310).

18. A multiport (200) for making optical connections, comprising:
a shell (210);

at least one connection port (236) comprising an optical connector opening (238) extending from an outer surface (234) of the multiport (200) into a cavity (216) and defining a connection port passageway (233), the connection port passageway (233) comprising a keying portion (233KP);

a securing feature passageway (245);

at least one securing feature (310) associated with the at least one connection port passageway (233), and the at least one securing feature (310) comprises a bore (310B) and a locking feature (310L), wherein the at least one securing feature is disposed within a portion of the securing feature passageway (245), and the at least one securing feature (310) is capable of translating within a portion of the at least one securing feature passageway (245) wherein the at least one securing feature (310) translates from a retain

position (RP) to an open position (OP) as a suitable fiber optic connector (10) is inserted into the at least one connection port (236).

19. The multiport of claim 18, wherein the locking feature (310L) comprises a ramp with a ledge.

20. The multiport of claim 19, wherein the locking feature (310L) comprises a retention surface (310RS).

21. A multiport (200) for making optical connections, comprising:
a shell (210);
at least one connection port (236) comprising an optical connector opening (238) extending from an outer surface (234) of the multiport (200) into a cavity (216) and defining a connection port passageway (233), the connection port passageway (233) comprising a keying portion (233KP);
a securing feature passageway (245);
at least one securing feature (310) associated with the at least one connection port passageway (233), and the at least one securing feature (310) comprises a locking member (310M) and an actuator (310A), wherein the at least one securing feature is disposed within a portion of the securing feature passageway (245), and the at least one securing feature (310) is capable of translating within a portion of the at least one securing feature passageway (245) wherein the at least one securing feature (310) translates from a retain position (RP) to an open position (OP) as a suitable fiber optic connector (10) is inserted into the at least one connection port (236).

22. The multiport of claim 21, wherein the locking member (310M) is a portion of a securing feature sub-assembly (310SA).

23. The multiport of any of claims 1-22, wherein the at least one connection port (236) and the at least one securing feature passageway (245) are a portion of the shell (210).

24. The multiport of claim 23, the shell (210) comprises at least a first portion (212) and a second portion (214).

25. The multiport of claim 23, wherein the shell (210) is formed from a plurality of components.

26. The multiport of any one of claims 1-22, wherein the at least one connection port (236) and the at least one securing feature passageway (245) are a portion of a connection port insert (230), the connection port insert (230) being sized so that a portion of the connection port insert (230) fits into a first opening of the shell (210).

27. The multiport of any one of claims 1-26, at least one optical fiber (250) routed from the at least one connection port (236) toward an input connection port (260) of the multiport (200).

28. The multiport of any one of claims 1-27, further comprising at least one adapter (230A) aligned with the at least one connection port (236).

29. The multiport of any one of claims 1-28, wherein the at least one securing feature (310) translates from a retain position (RP) to an open position (OP) as a suitable fiber optic connector (10) is inserted into the at least one connection port (236).

30. The multiport of any one of claims 1-29, wherein the keying portion (233KP) comprises a male key.

31. The multiport of any one of claims 1-30, further comprising a sealing feature 310S disposed on the at least one securing feature (310).

32. The multiport of any one of claims 1-31, wherein at least a portion of the one securing feature passageway (245) is arranged transversely to a longitudinal axis (LA) of the connector port passageway (233).

33. The multiport of any one of claims 1-31, wherein at least a portion of the one securing feature passageway (245) is arranged in the same direction as a longitudinal axis (LA) of the connector port passageway (233).

34. The multiport of any one of claims 1-33, further comprising at least one adapter (230A) aligned with the at least one connector port passageway (233).

35. The multiport of any one of claims 1-33, further comprising at least one adapter (230A) is capable of floating relative to the at least one connection ports passageway (233).

36. The multiport of any one of claims 1-33, further comprising at least one adapter (230A) biased by a resilient member (230RM).

37. The multiport claims 35 or 36, further comprising a retainer (240) for securing the at least one adapter (230A) to the shell (210).

38. The multiport of any one of claims 1-37, further comprising at least one rear connector (252) comprising a rear connector ferrule.

39. The multiport of claim 38, the at least one rear connector (252) further comprising a resilient member for biasing the rear connector ferrule.

40. The multiport of any one of claims 1-37, further comprising at least one rear connector (252) further comprising a keying feature.

41. The multiport of any one of claims 1-37, further comprising at least one rear connector (252) having a SC footprint.

42. The multiport of any one of claims 1-41, wherein the multiport (200) is weatherproof.

43. The multiport of any one of claims 1-42, further comprising an optical splitter (275) disposed within the cavity (216).

44. The multiport of any of claims 1-43, further comprising at least one mounting feature (210MF) for the multiport (200).

45. The multiport of any one of claims 1-44, the multiport comprising at least one pass-through port.

46. The multiport of any one of claims 1-45, further comprising an input connection port (260) configured as a single-fiber input connection or a multi-fiber input connection.

47. The multiport of any one of claims 1-45, further comprising an input connection port (260) configured as an input tether (270).

48. The multiport of claim 47, wherein the input tether (270) further comprises a furcation body (270F).

49. The multiport of claims 47 or 48, wherein the input tether (270) is terminated with a fiber optic connector (278).

50. The multiport of any one of claims 1-49, further comprising at least one fiber routing guide (230G) or support (230S).

51. The multiport of any one of claims 1-50, wherein the shell (210) defines a volume of 800 cubic centimeters or less.

52. The multiport of any one of claims 1-50, wherein the shell (210) defines a volume of 400 cubic centimeters or less.

53. The multiport of any one of claims 1-50, wherein the shell (210) defines a volume of 100 cubic centimeters or less.

54. The multiport of any one of claims 1-53, wherein the multiport has a port width density of at least one connection port (236) per 20 millimeters of width (W).

55. The multiport of any one of claims 1-54, further comprising a sealing element (290).

56. The multiport of any one of claims 1-55, further comprising a dust cap (295) sized for cooperating with the at least one optical connector opening (238).

57. The multiport of any one of claims 1-56, wherein the multiport comprises a marking indicia for the at least one connection port passageway (233).

58. The multiport of any one of claims 1-57, wherein at least one connection port (236) is suitable for retaining a suitable fiber optic connector (10) when the fiber optic connector (10) is fully-seated within the at least one connection port (236).

59. The multiport of any one of claims 1-58, further comprising a cover.

60. The multiport of claim 59, further comprising a bracket for the cover.

61. A wireless device (500), comprising:

a shell (210);

at least one connection port (236) on the wireless device (500), the at least one connection port (236) comprising an optical connector opening (238) extending from an outer surface (234) of the wireless device (500) into a cavity (216) of the wireless device (500) and defining a connection port passageway (233), the connection port passageway (233) comprising a keying portion (233KP);

at least one securing feature passageway (245); and

at least one securing feature (310) associated with the connection port passageway (233), wherein the at least one securing feature (310) is disposed within a portion of the at least one securing feature passageway (245).

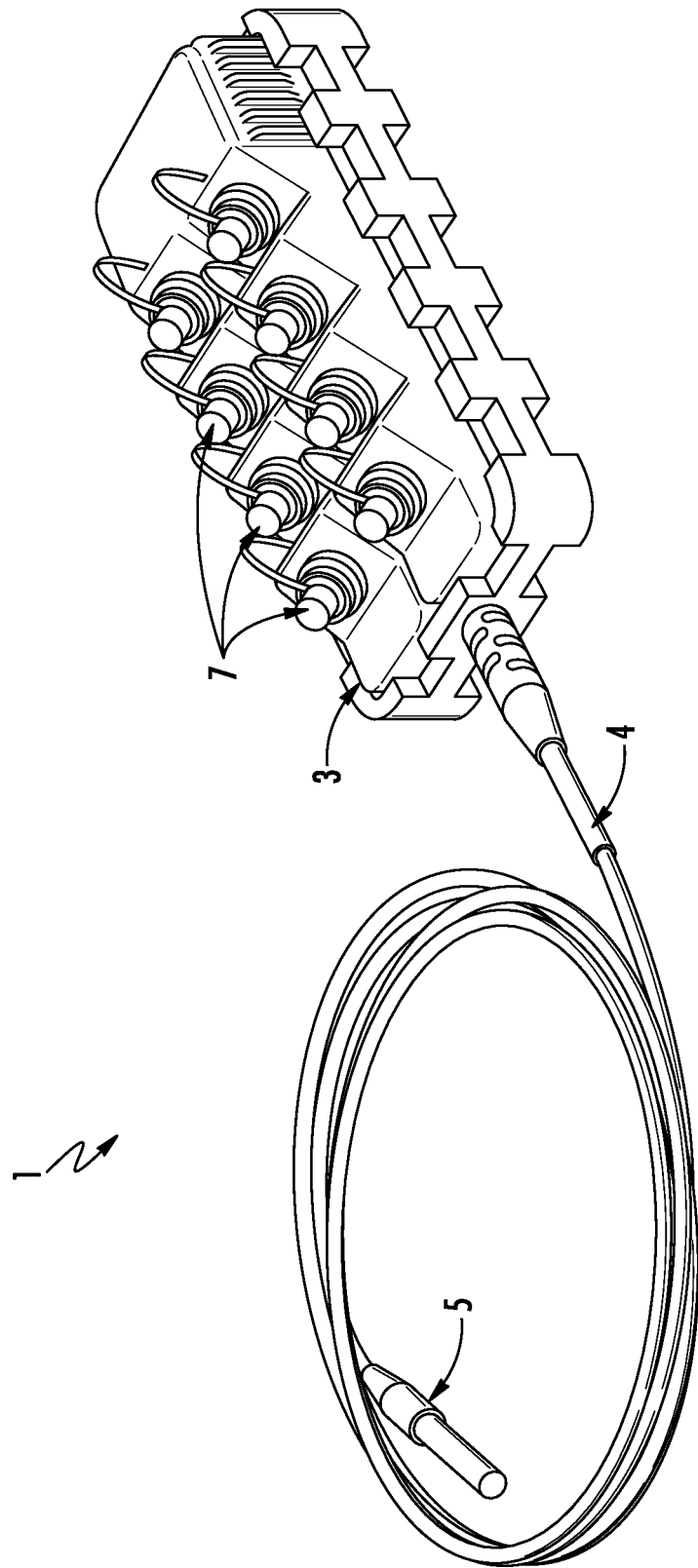

FIG. 1

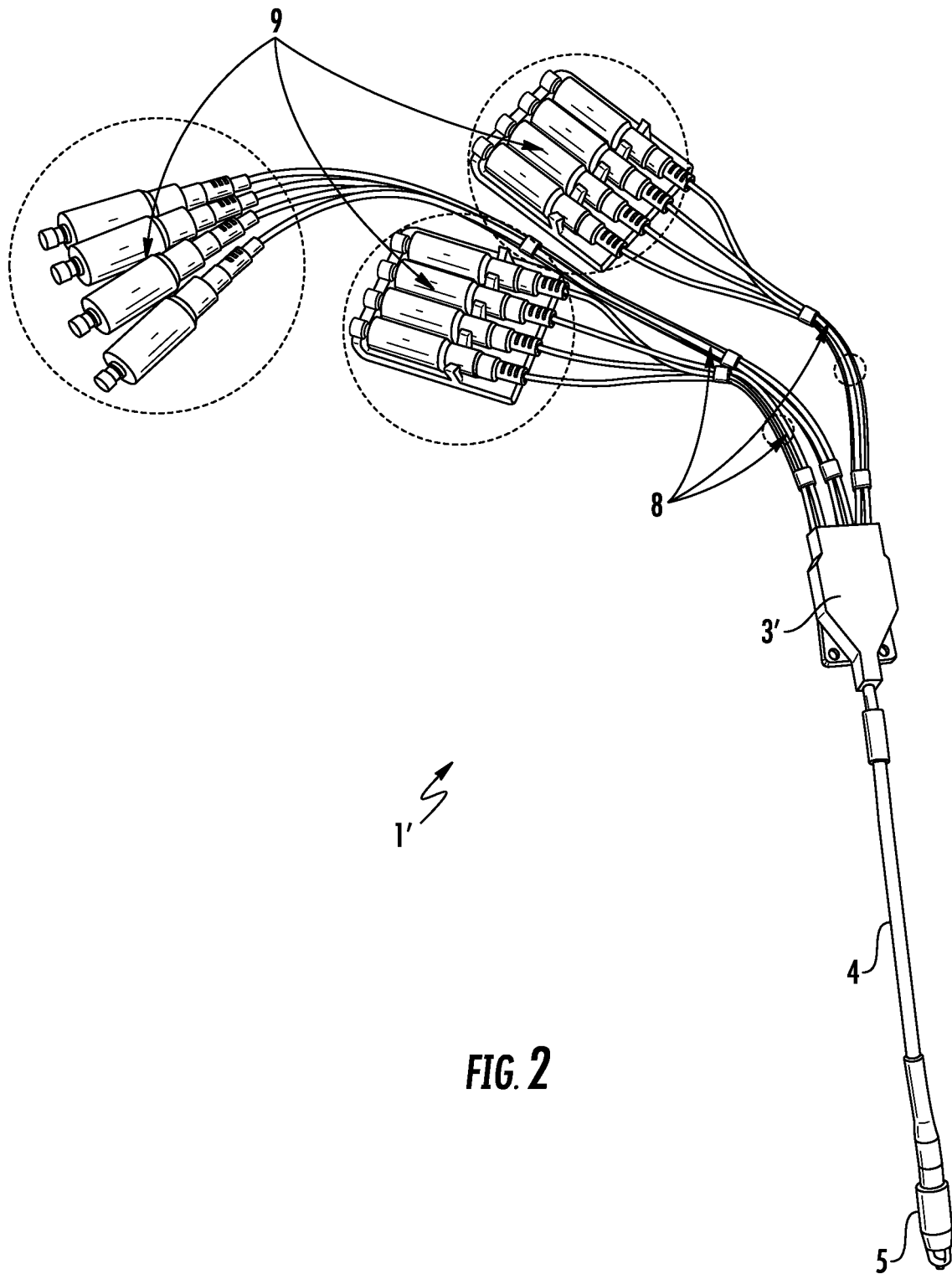

FIG. 2

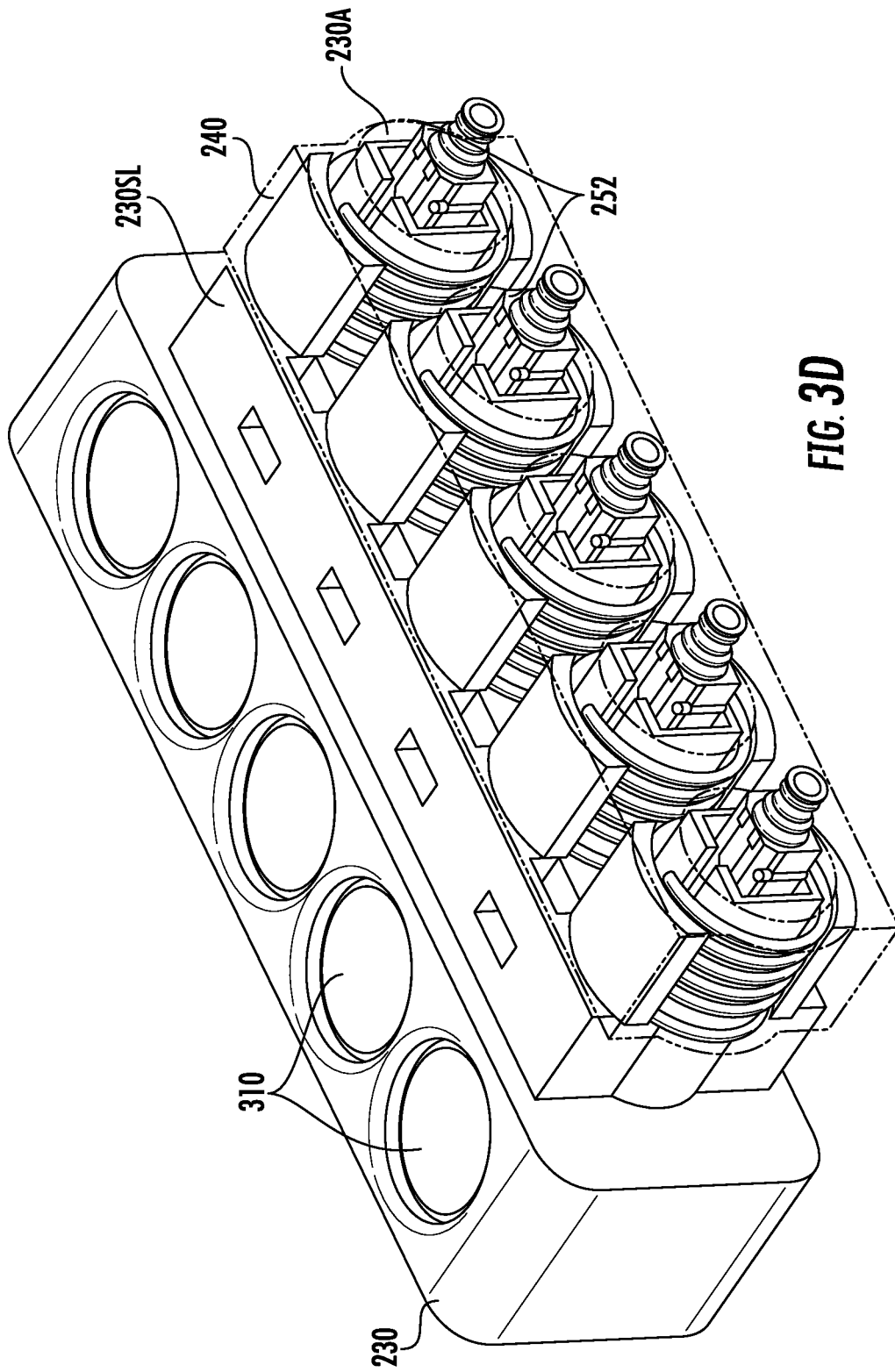

FIG. 3D

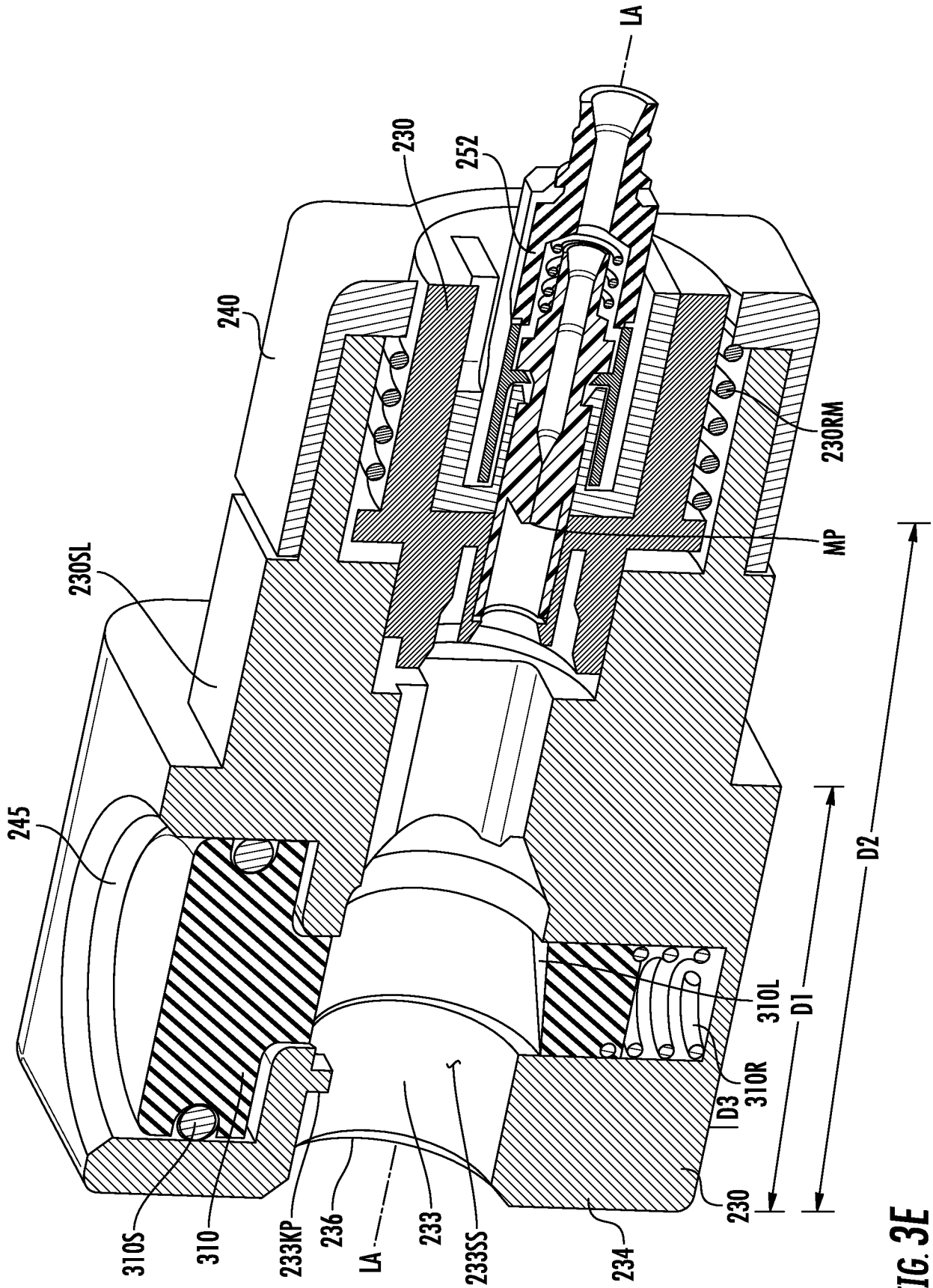

FIG. 3E

8/85

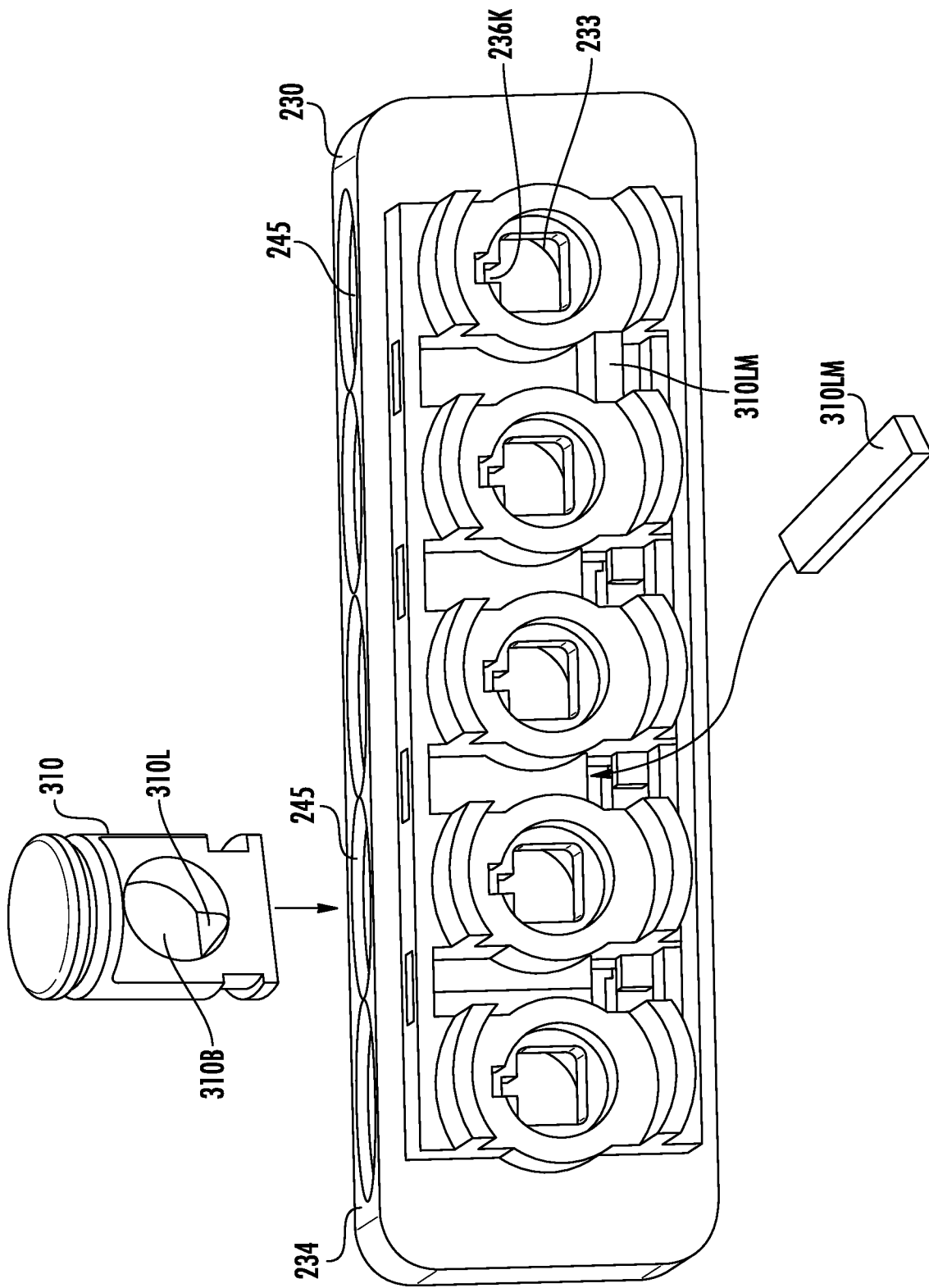

FIG. 3F

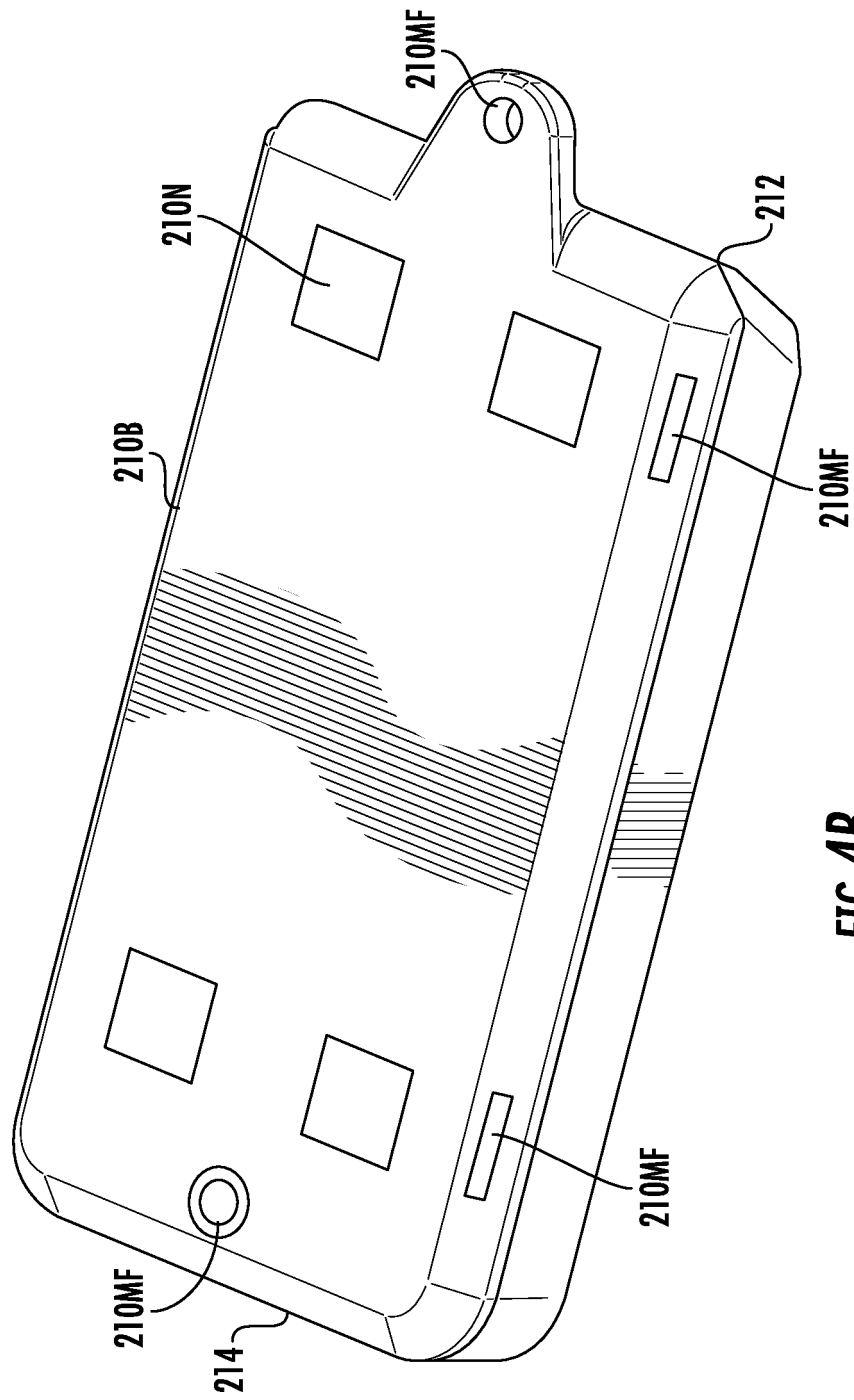

FIG. 4B

11/85

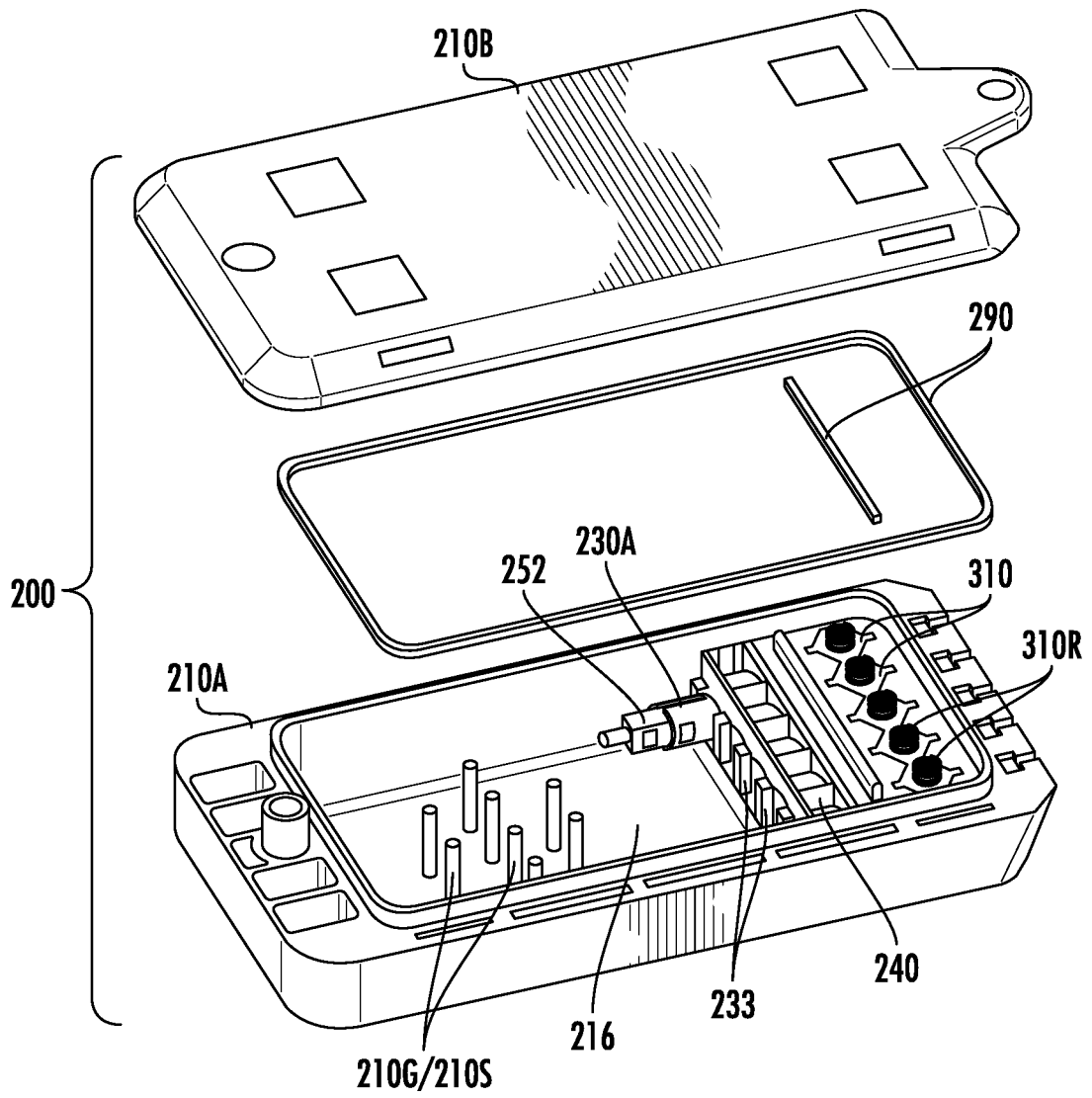

FIG. 5

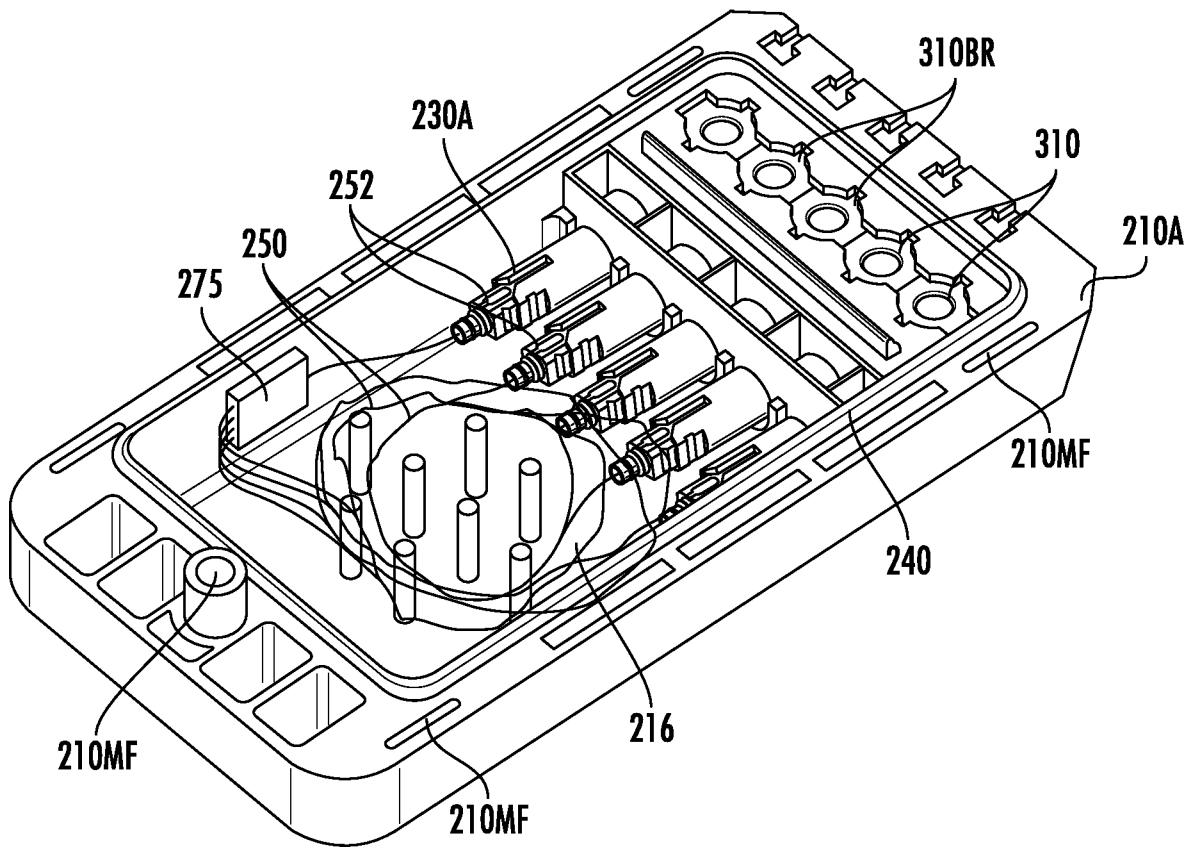

FIG. 6

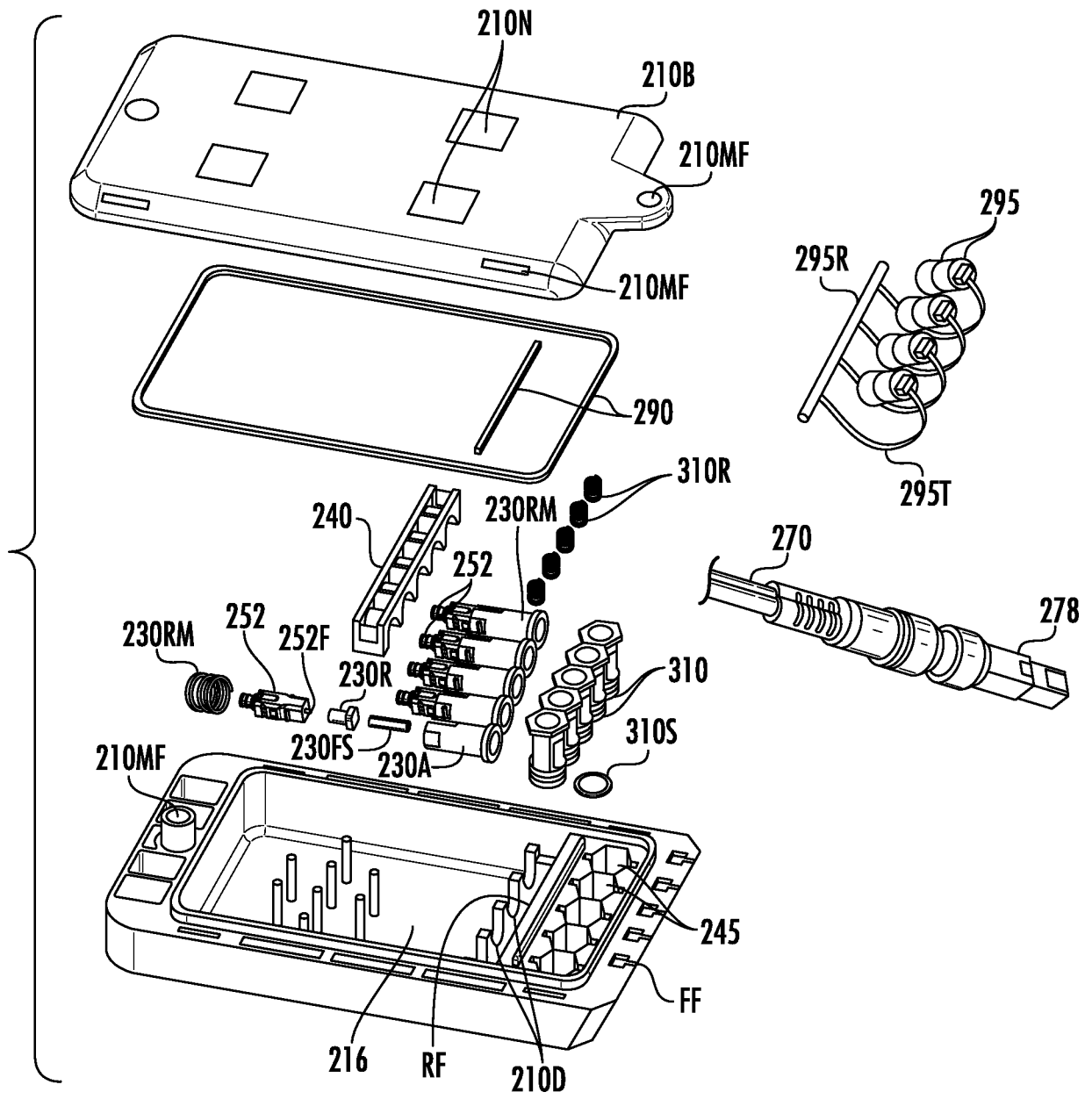
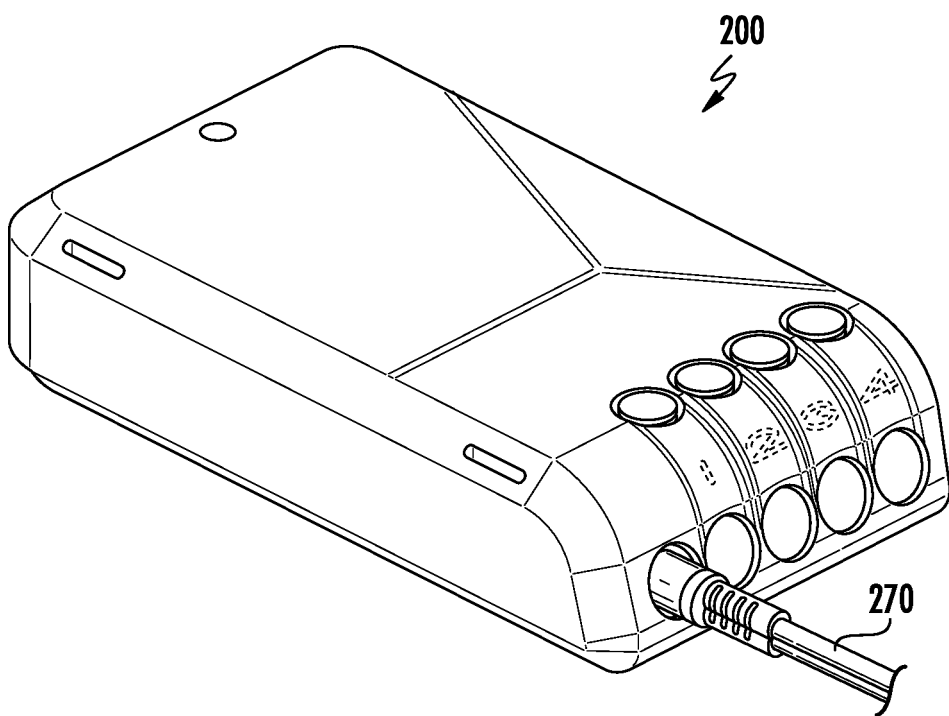
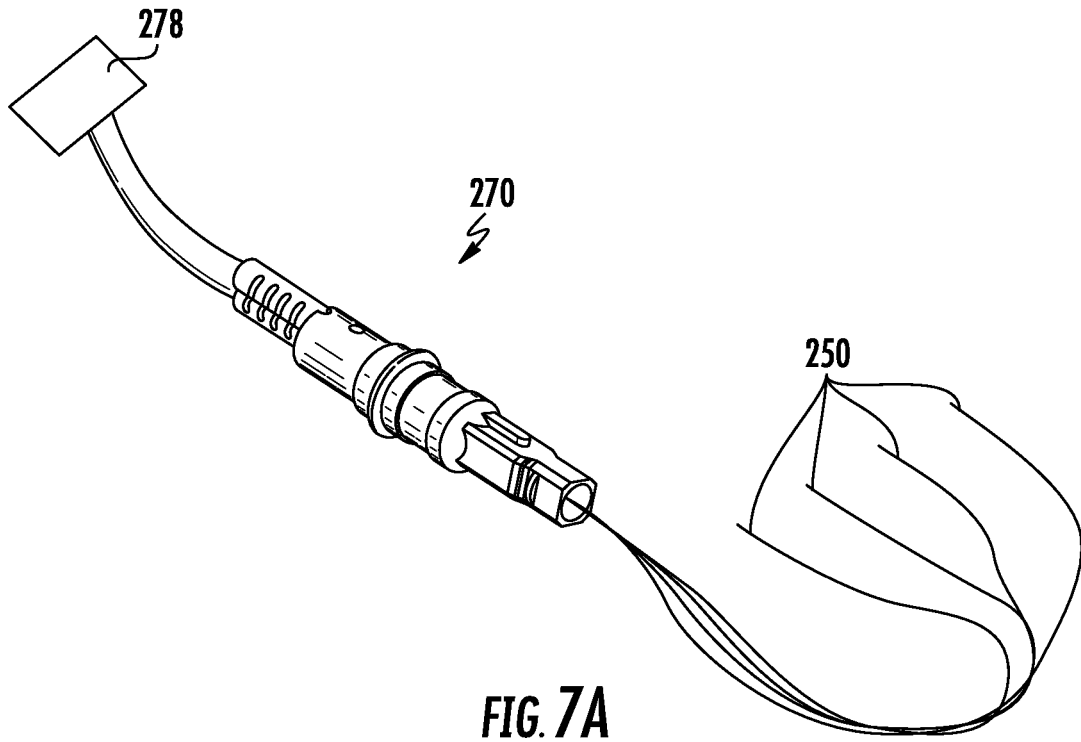

FIG. 7

14/85



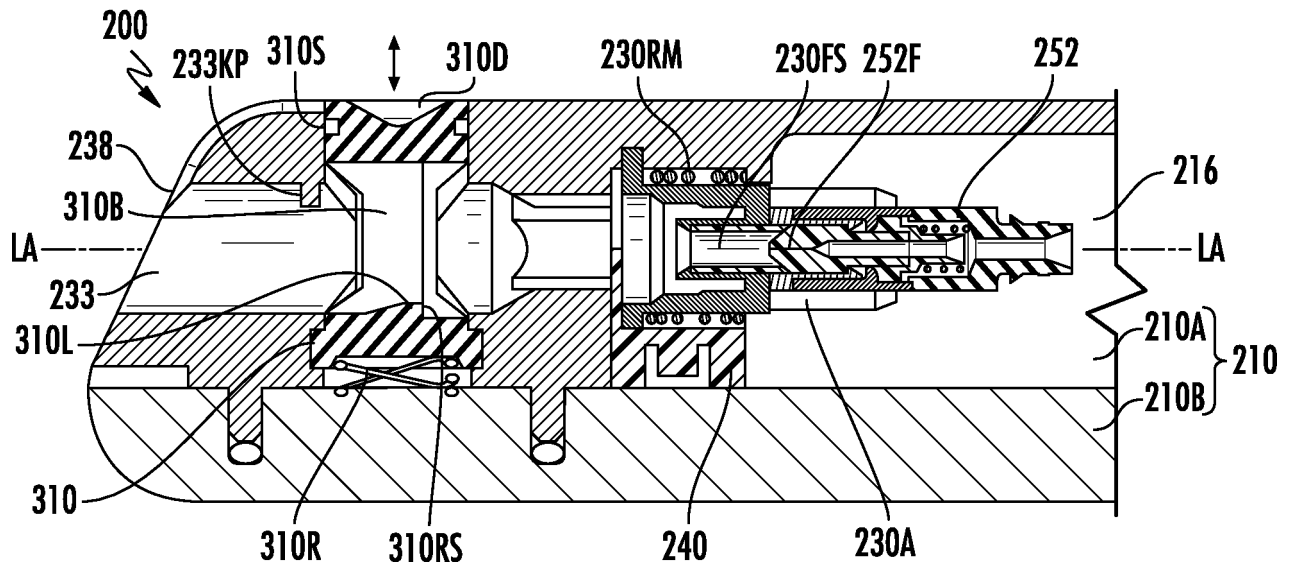

FIG. 8

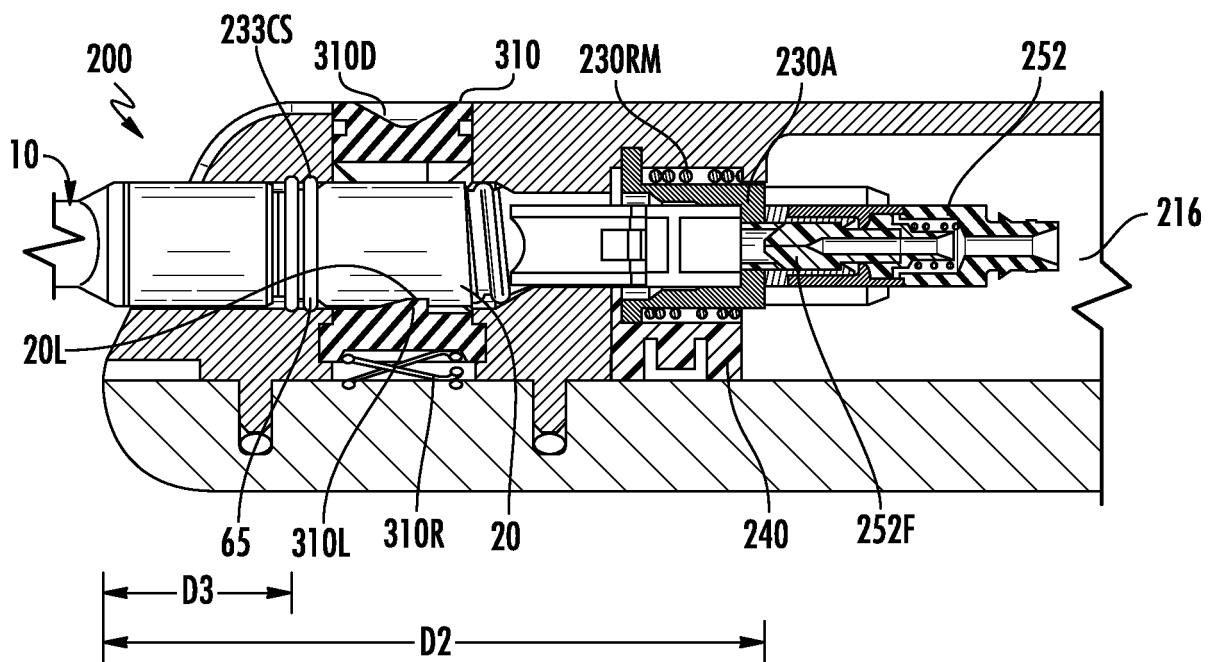

FIG. 9

16/85

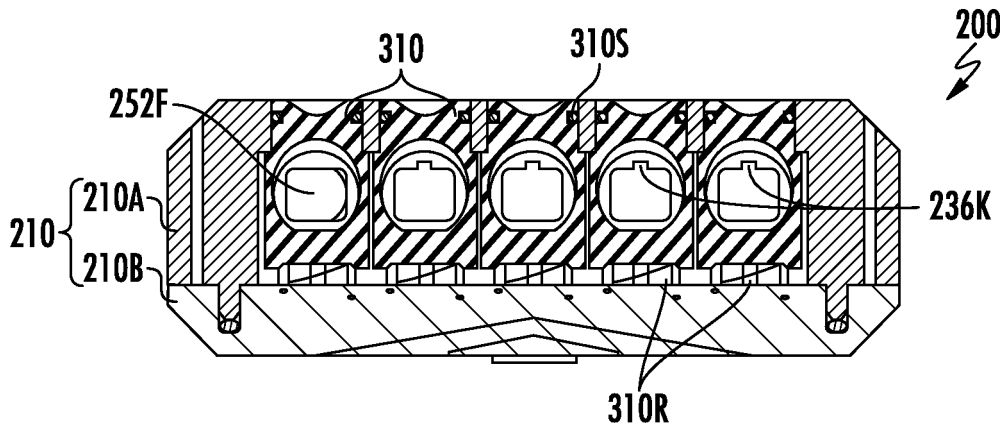

FIG. 10

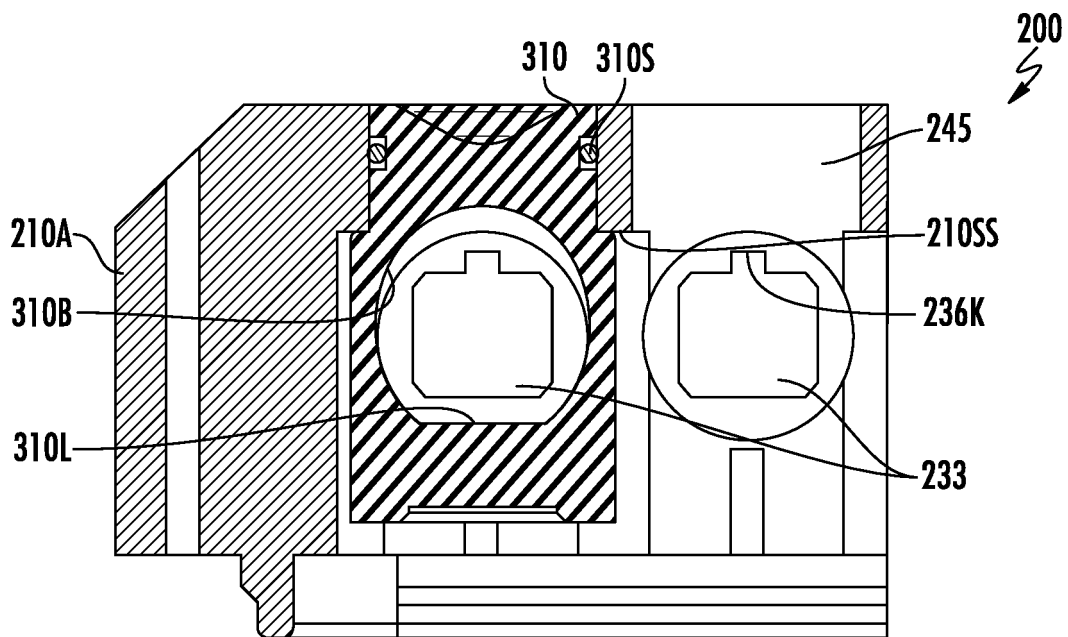

FIG. 11

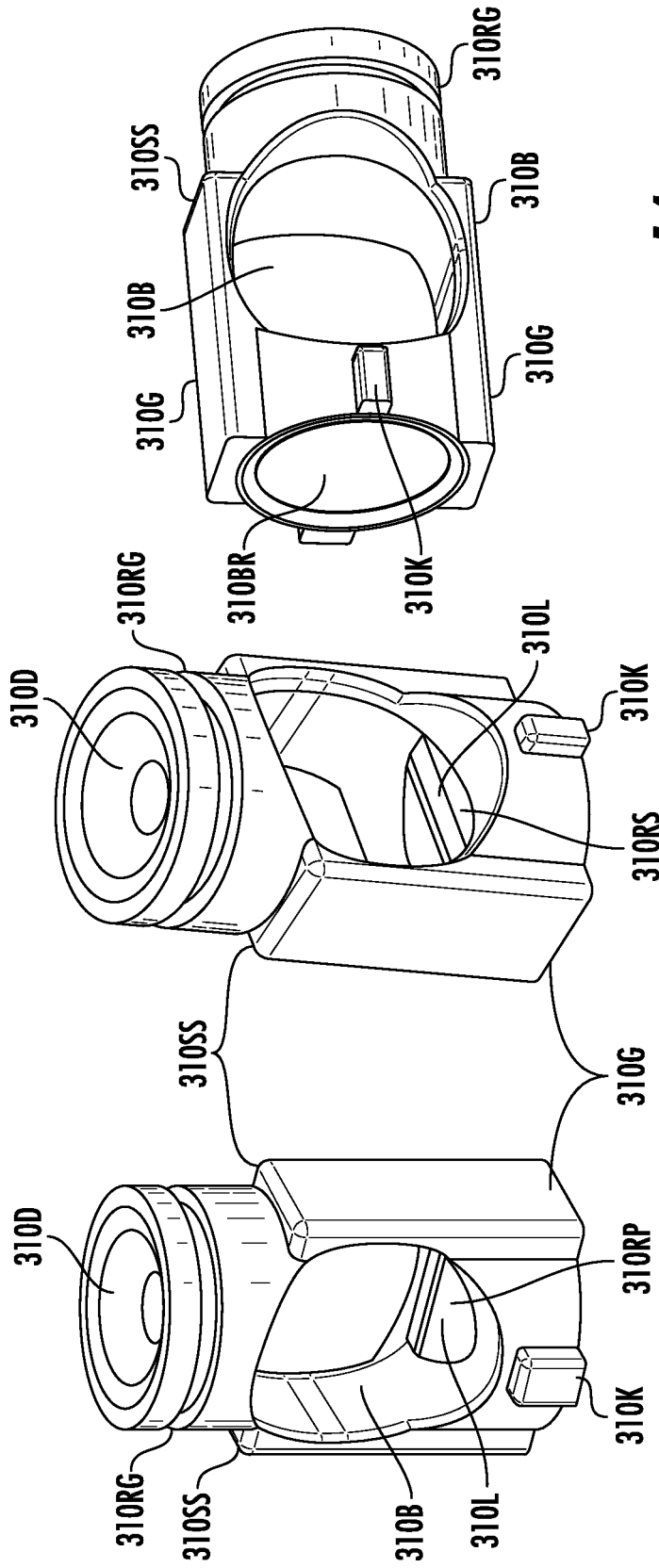

FIG. 12

FIG. 13

FIG. 14

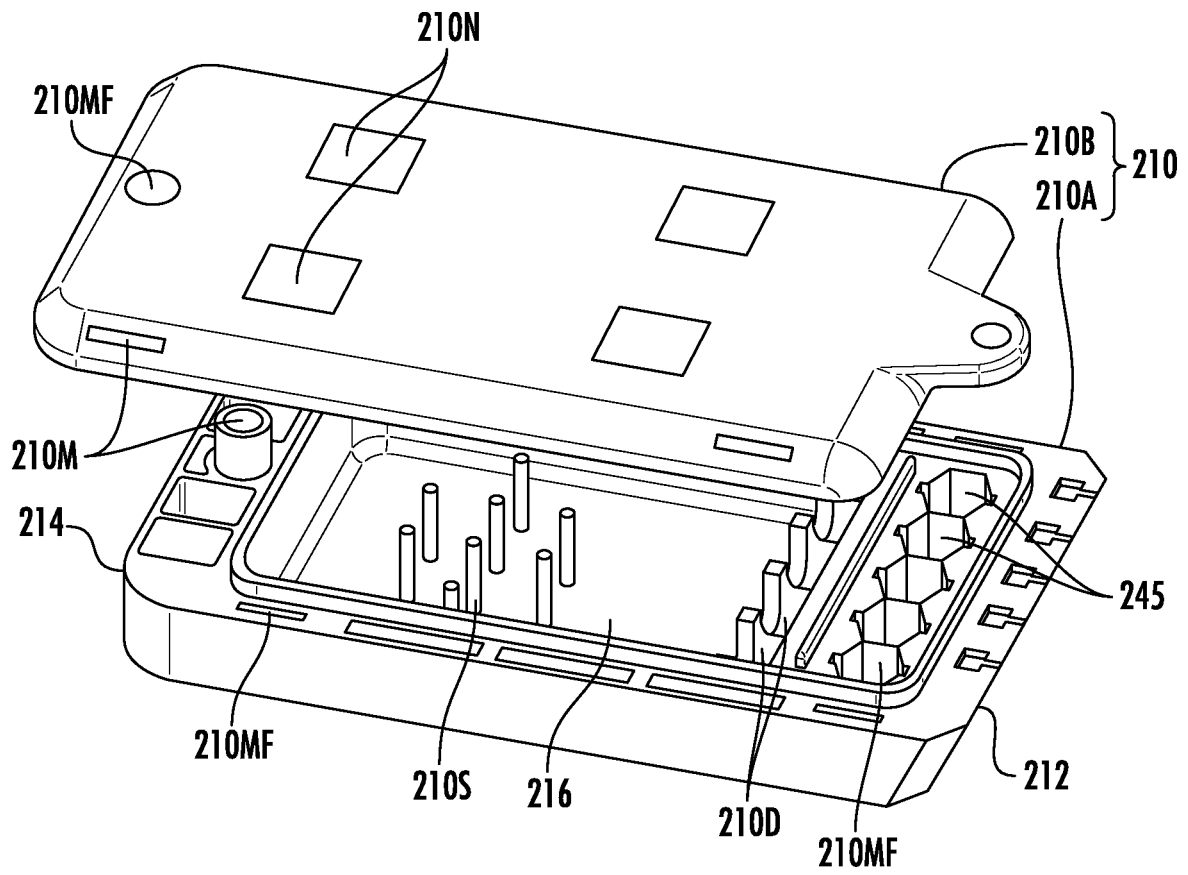

FIG. 15

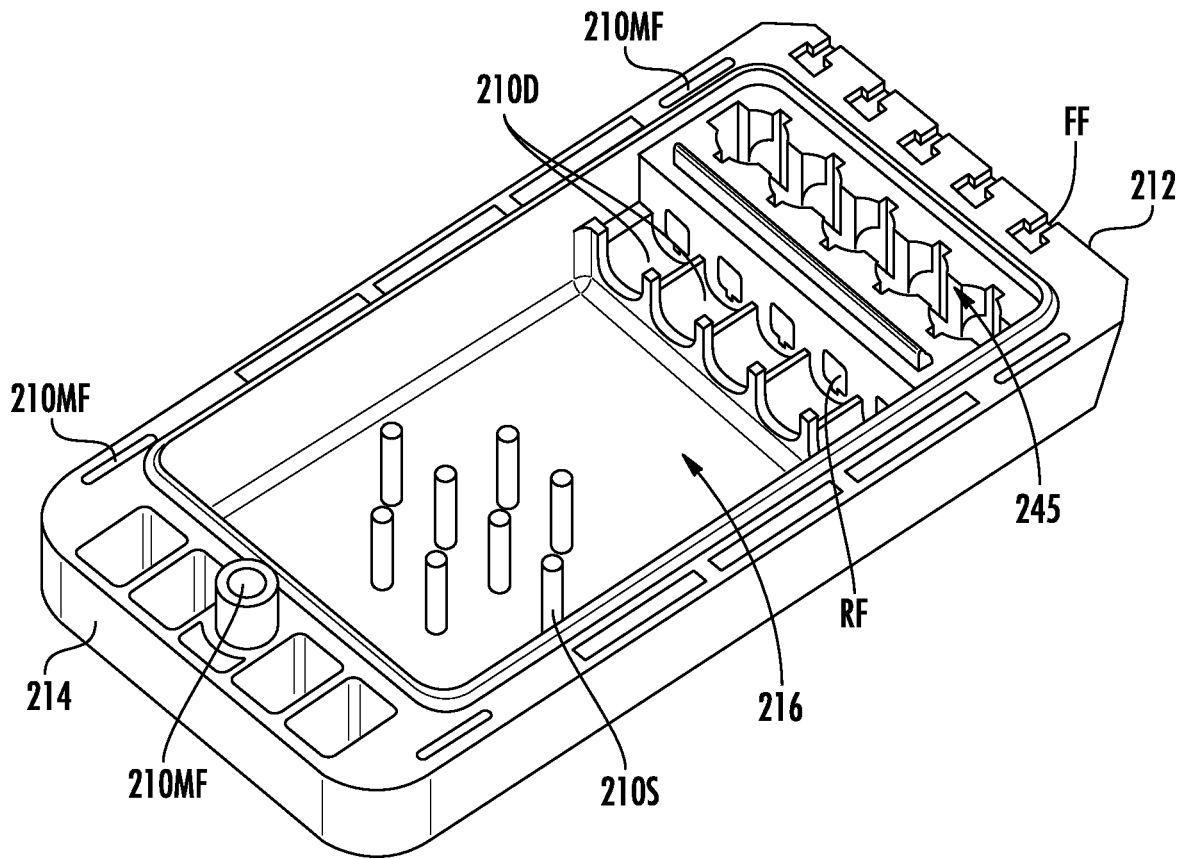

FIG. 16

20/85

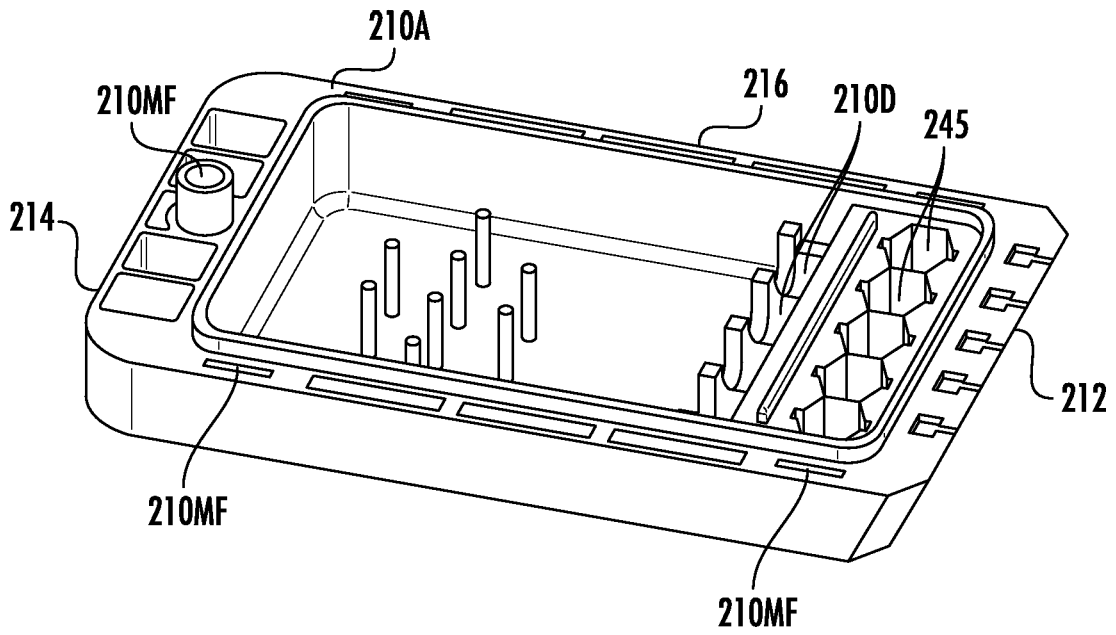

FIG. 17

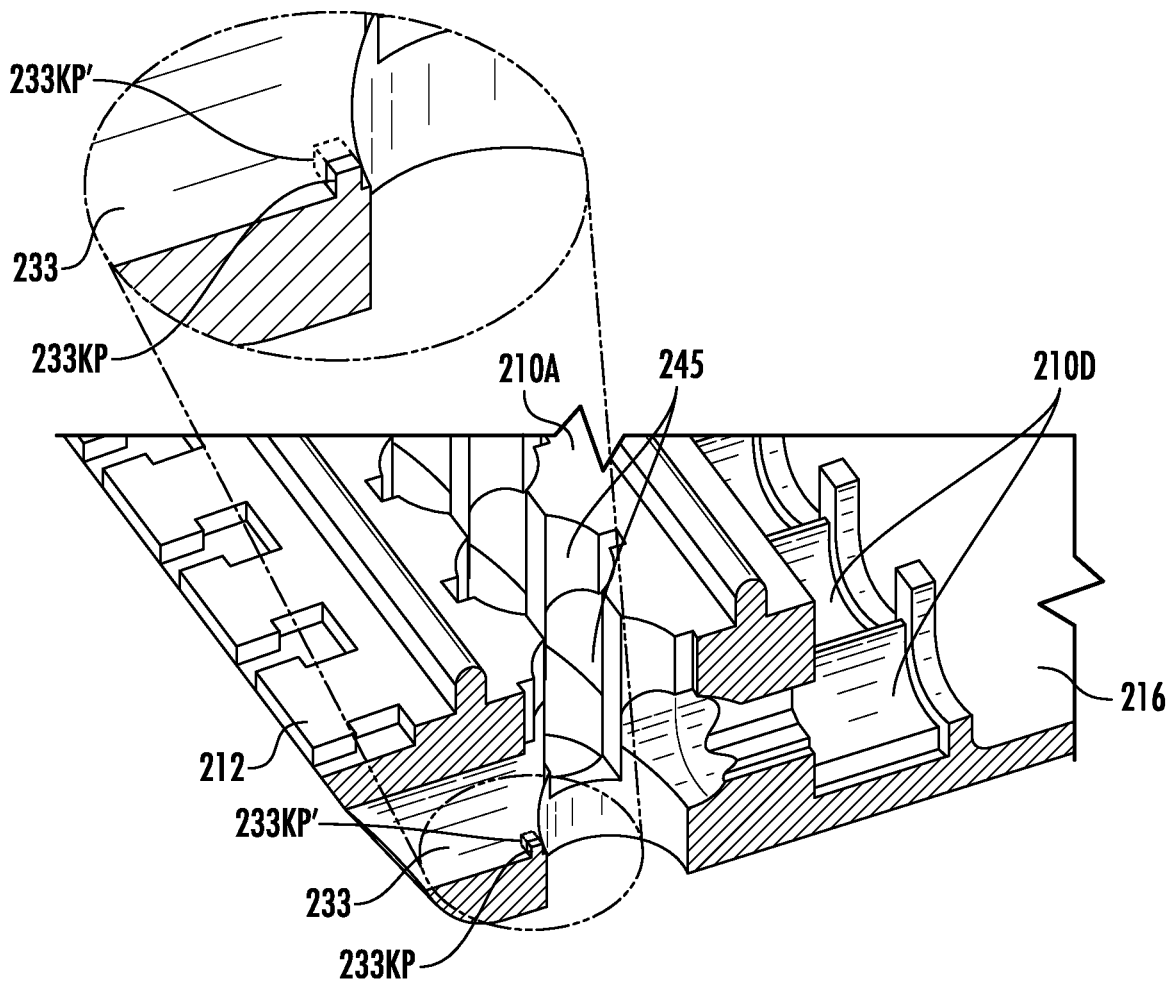

FIG. 18

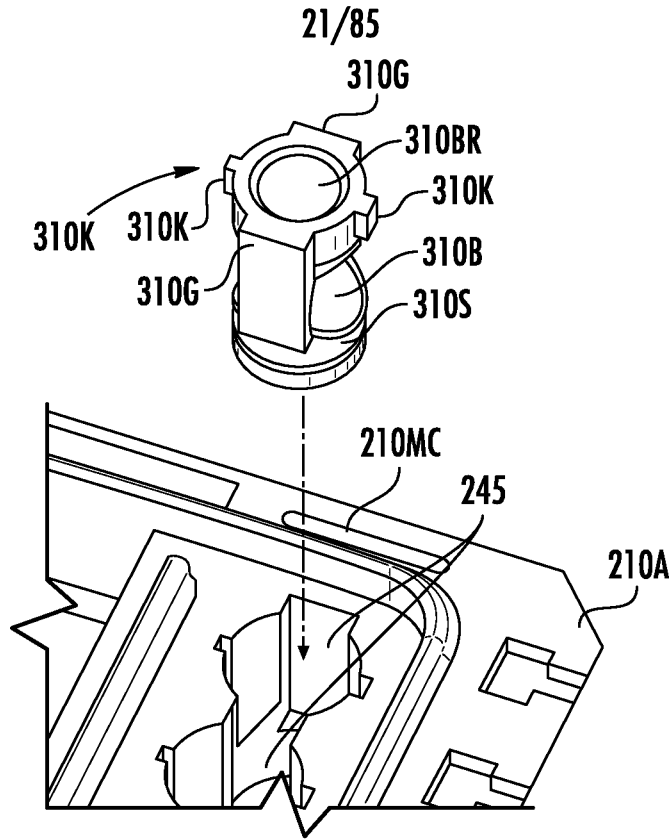

FIG. 19

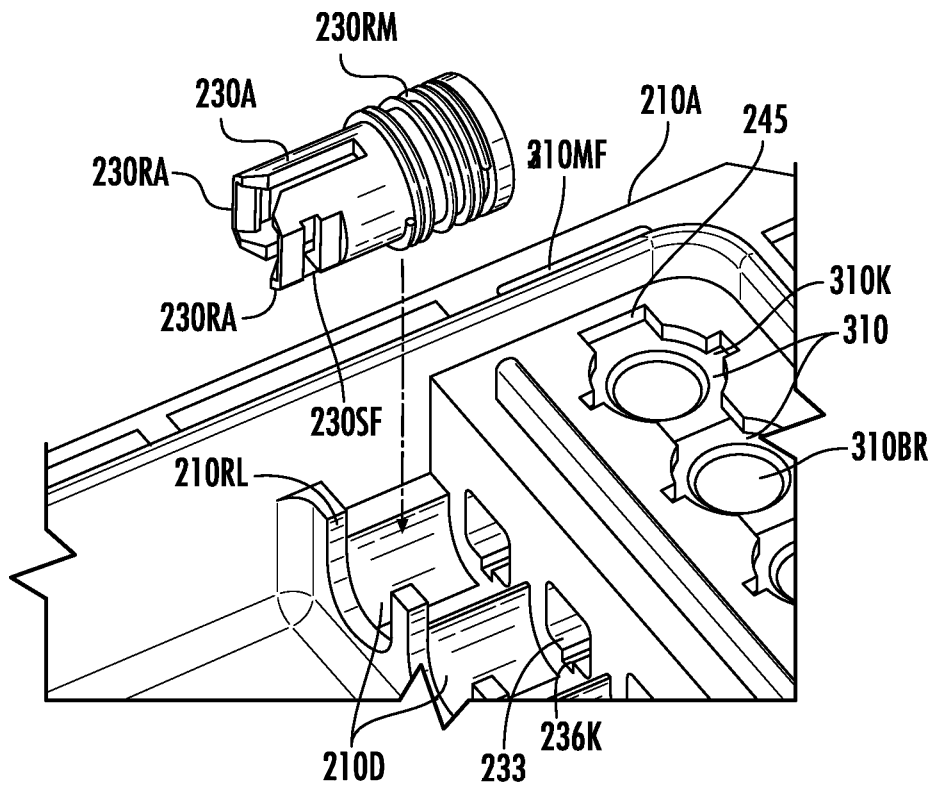

FIG. 20

22/85

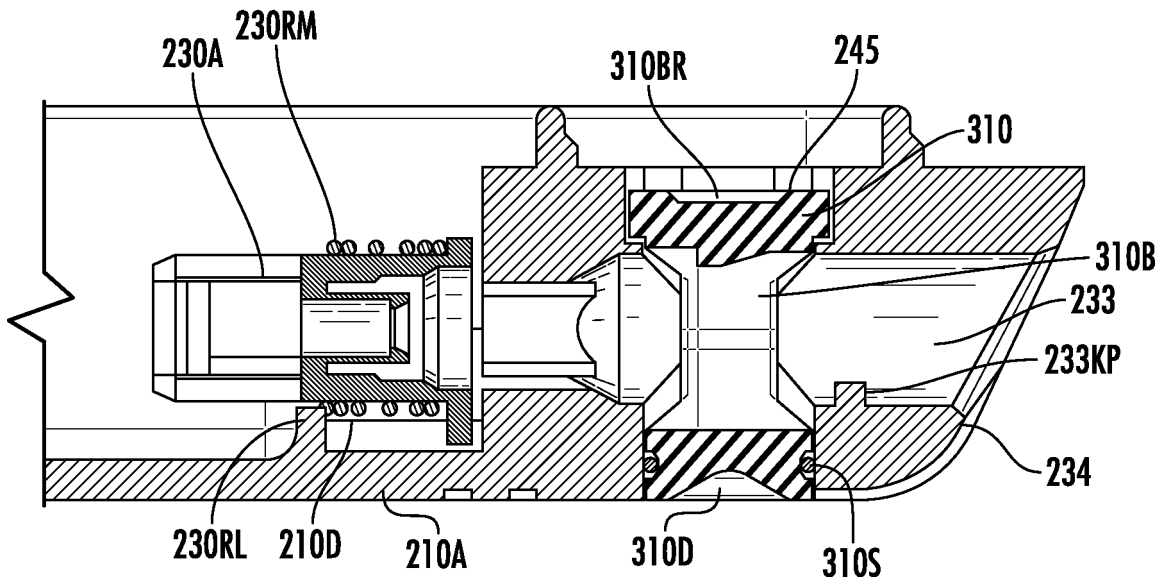

FIG. 21

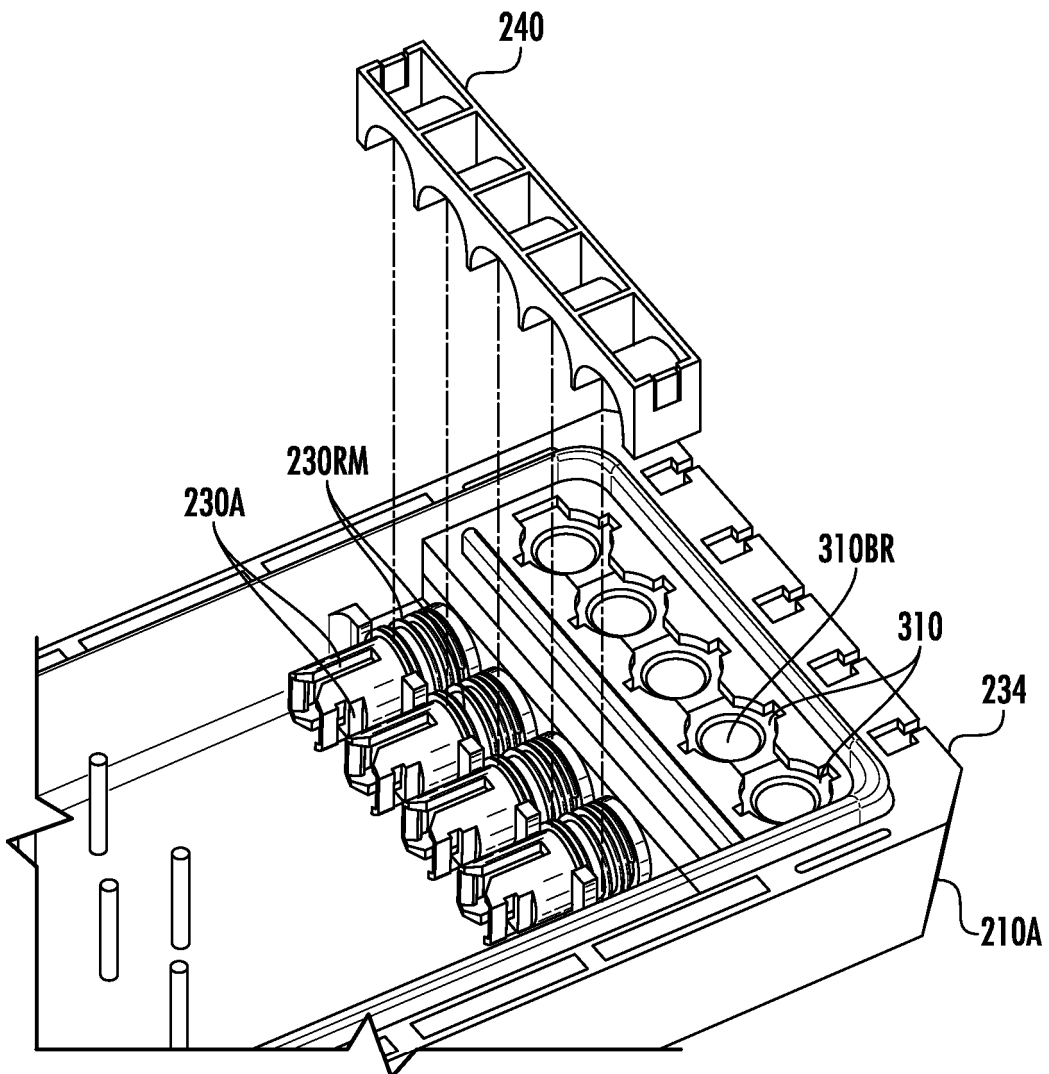

FIG. 22

23/85

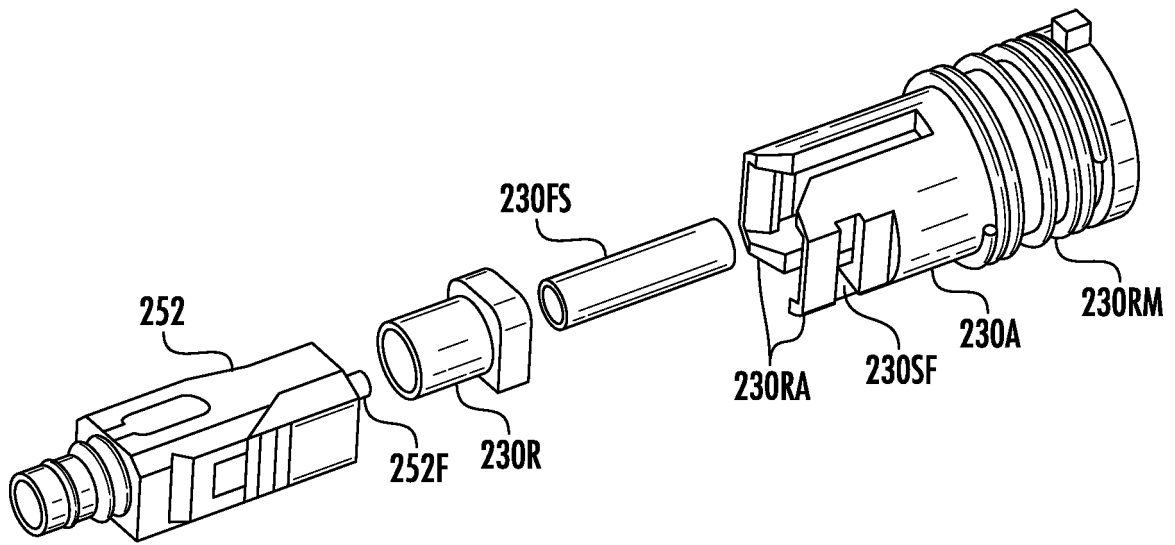

FIG. 23

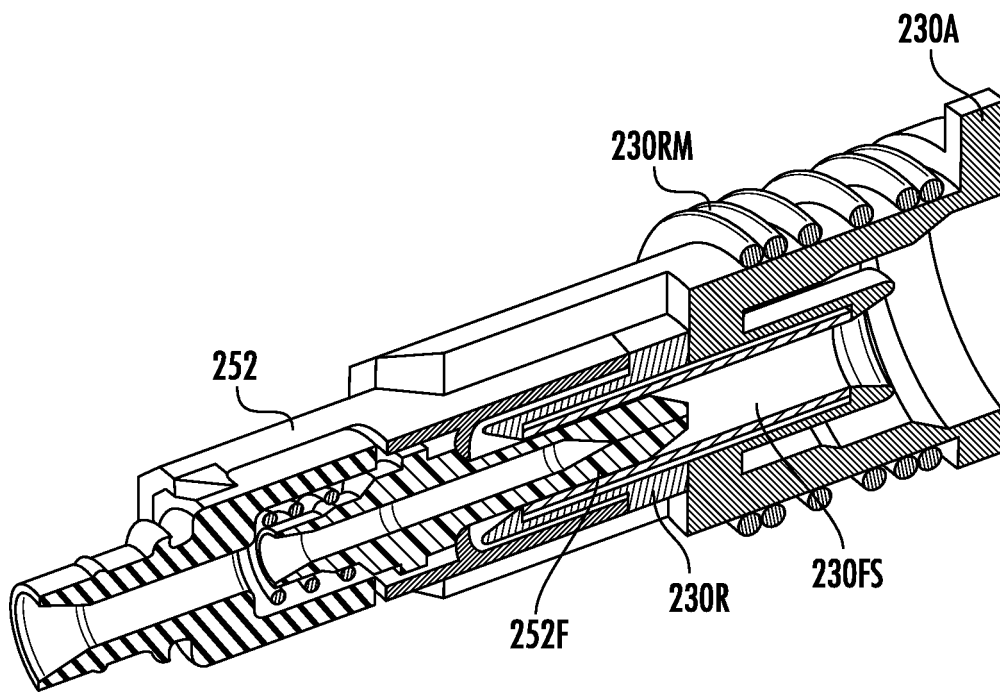

FIG. 23A

24/85

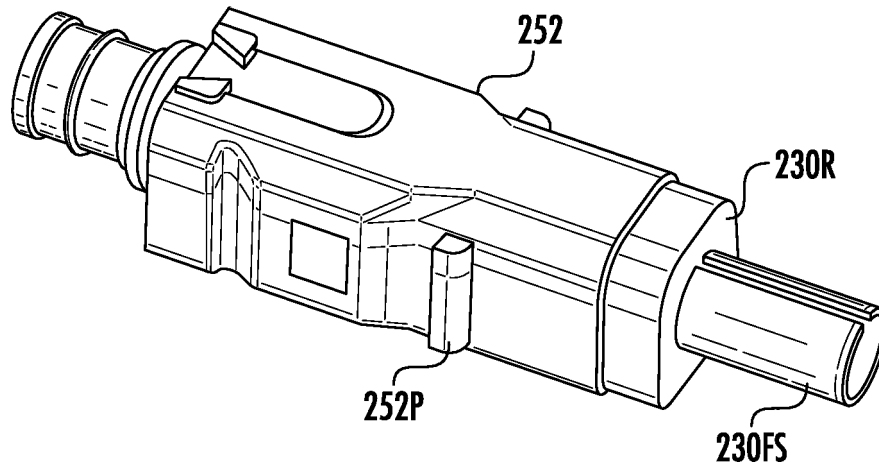

FIG. 24

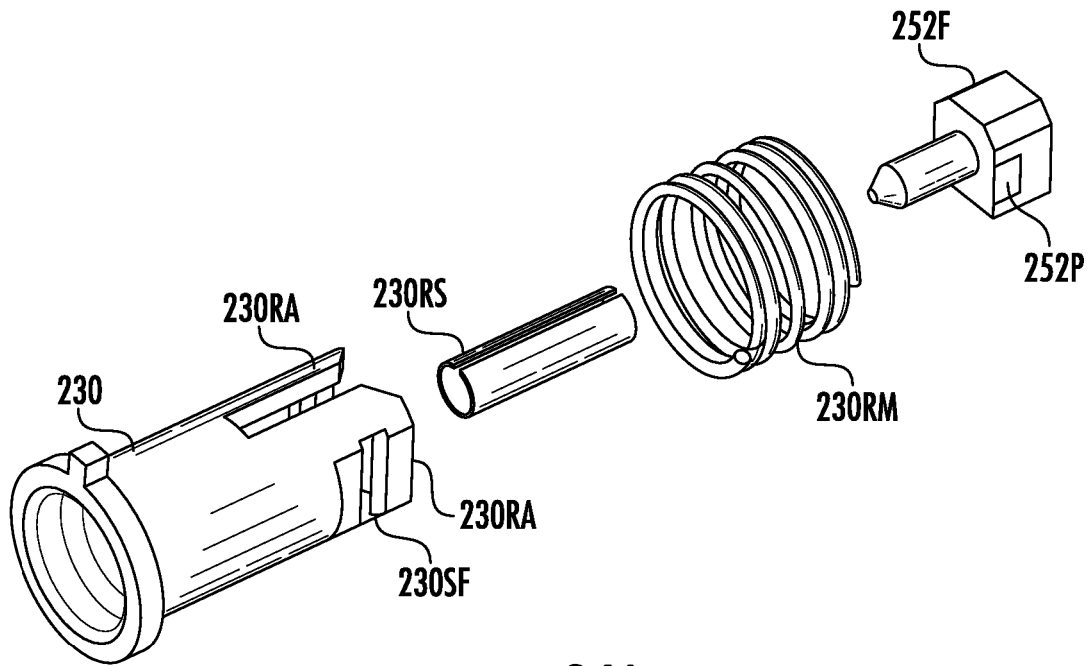

FIG. 24A

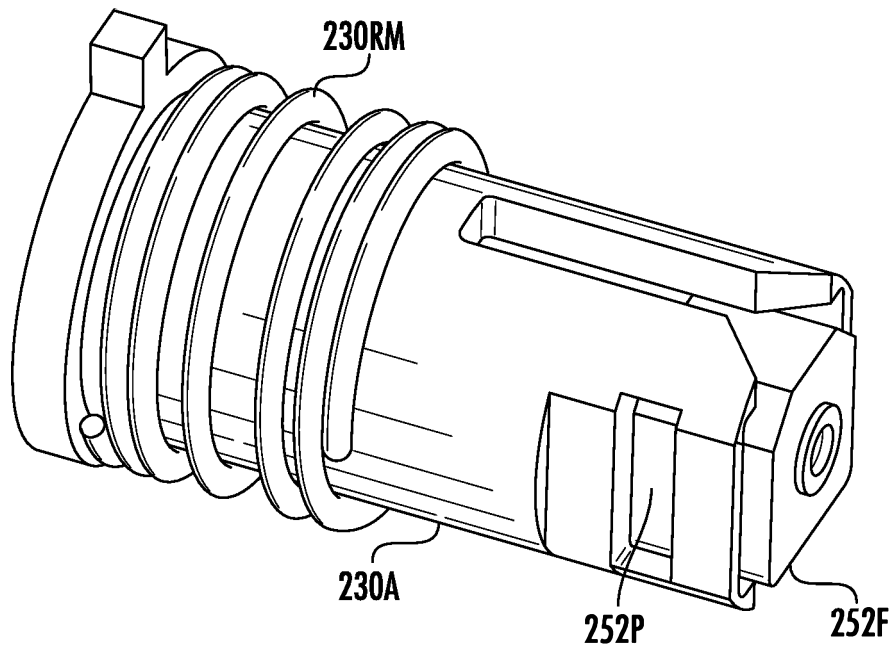

FIG. 24B

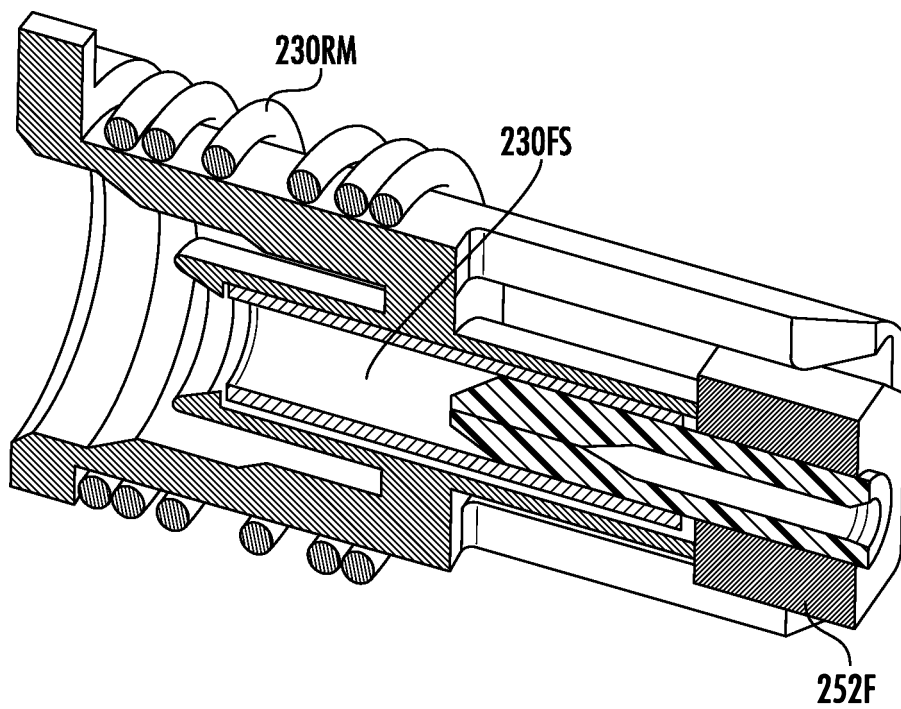

FIG. 24C

26/85

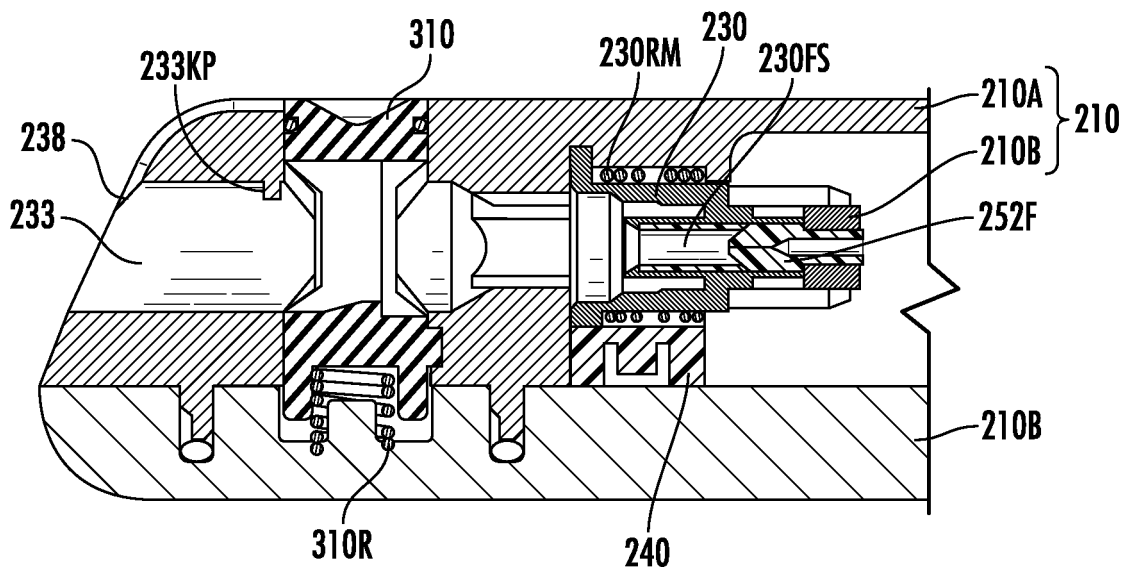

FIG. 24D

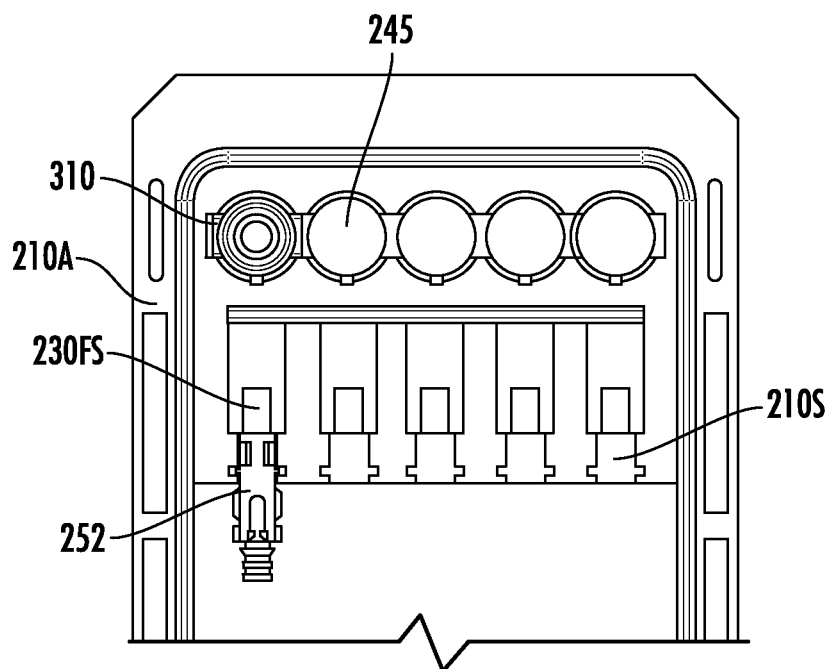

FIG. 24E

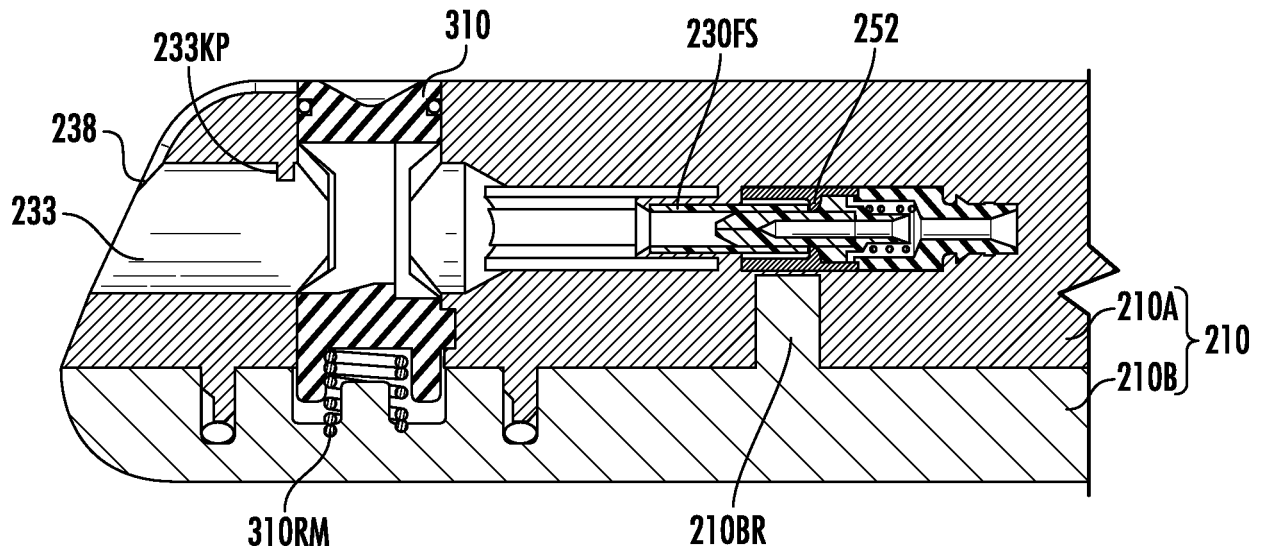

FIG. 24F

28/85

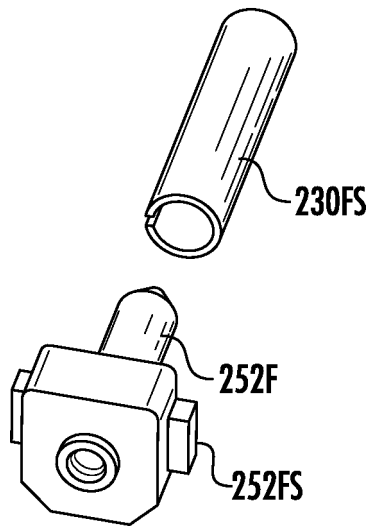

FIG. 24G

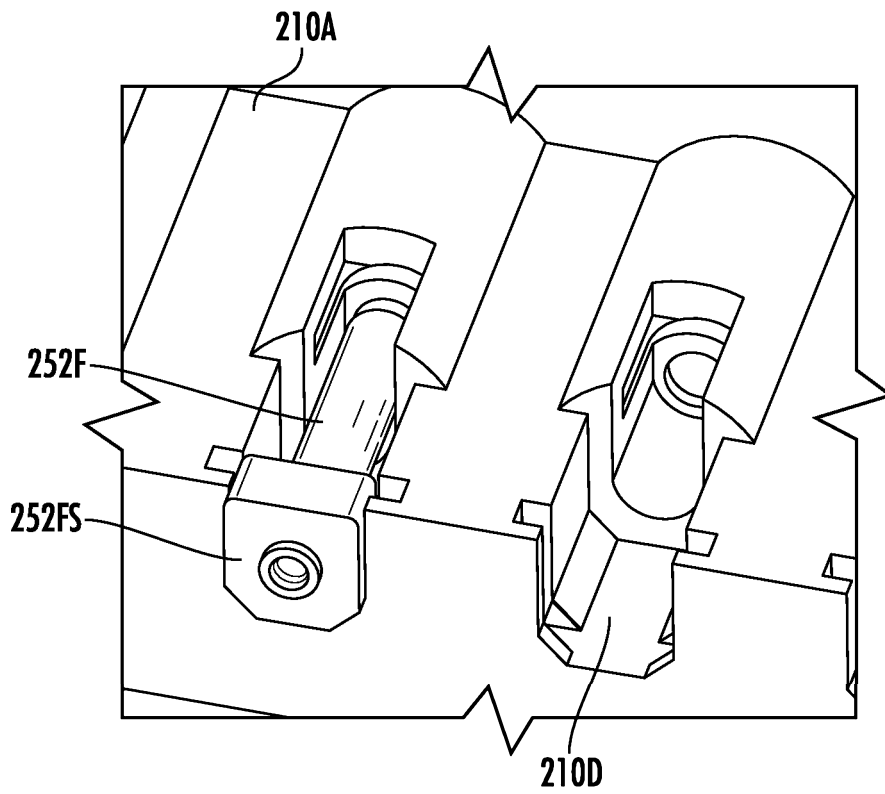

FIG. 24H

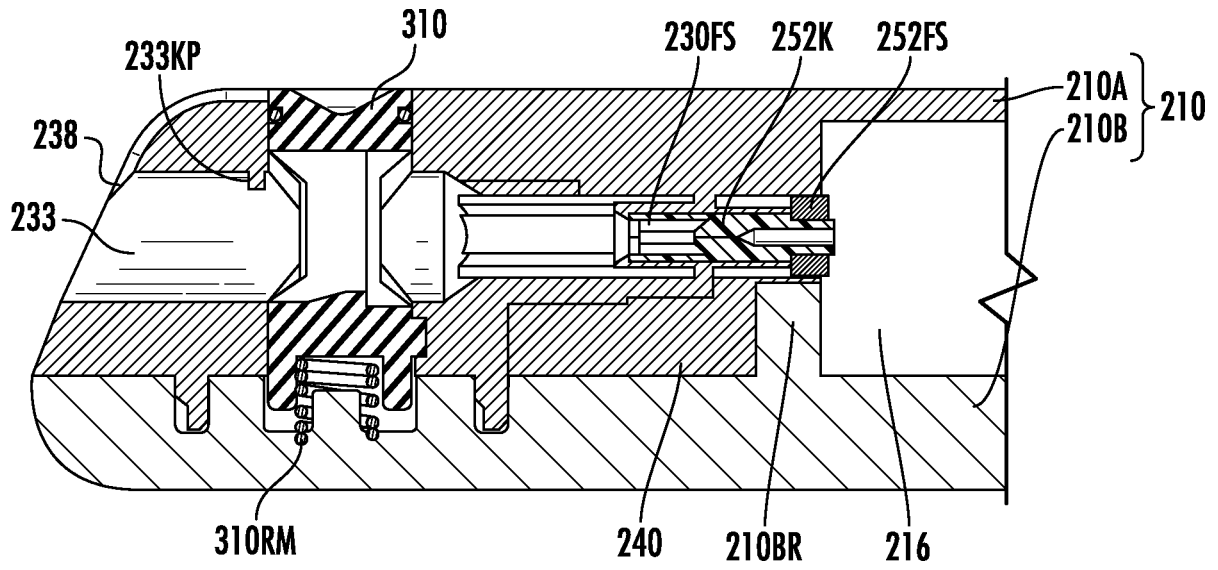

FIG. 24I

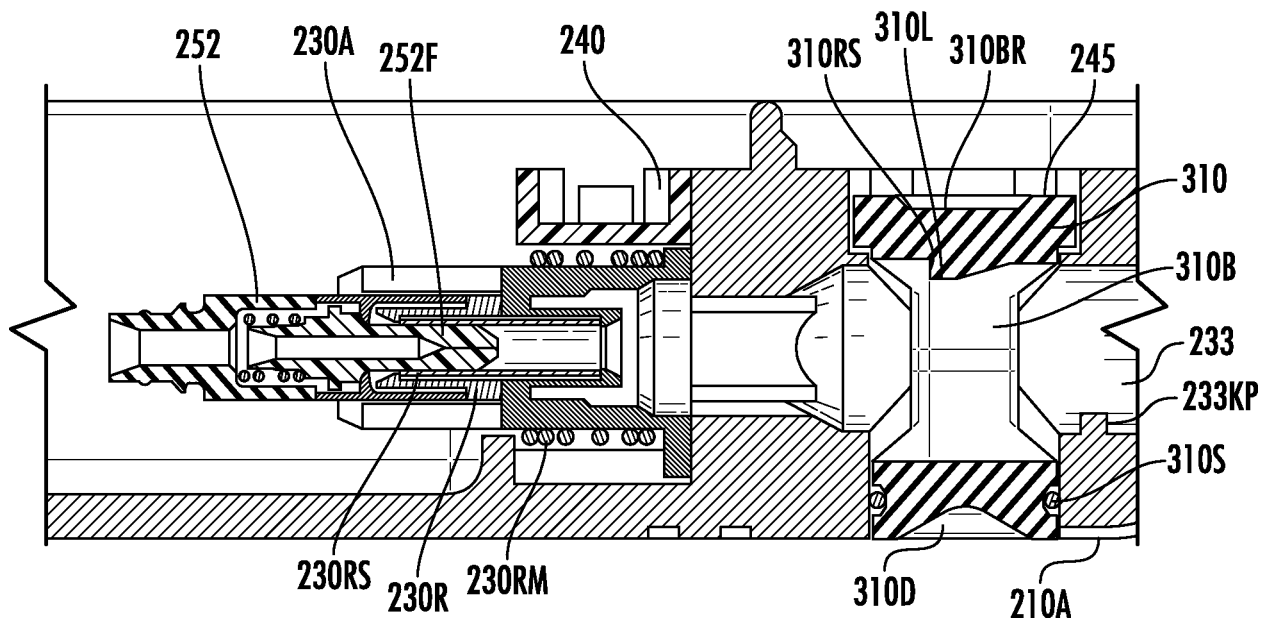

FIG. 25

31/85

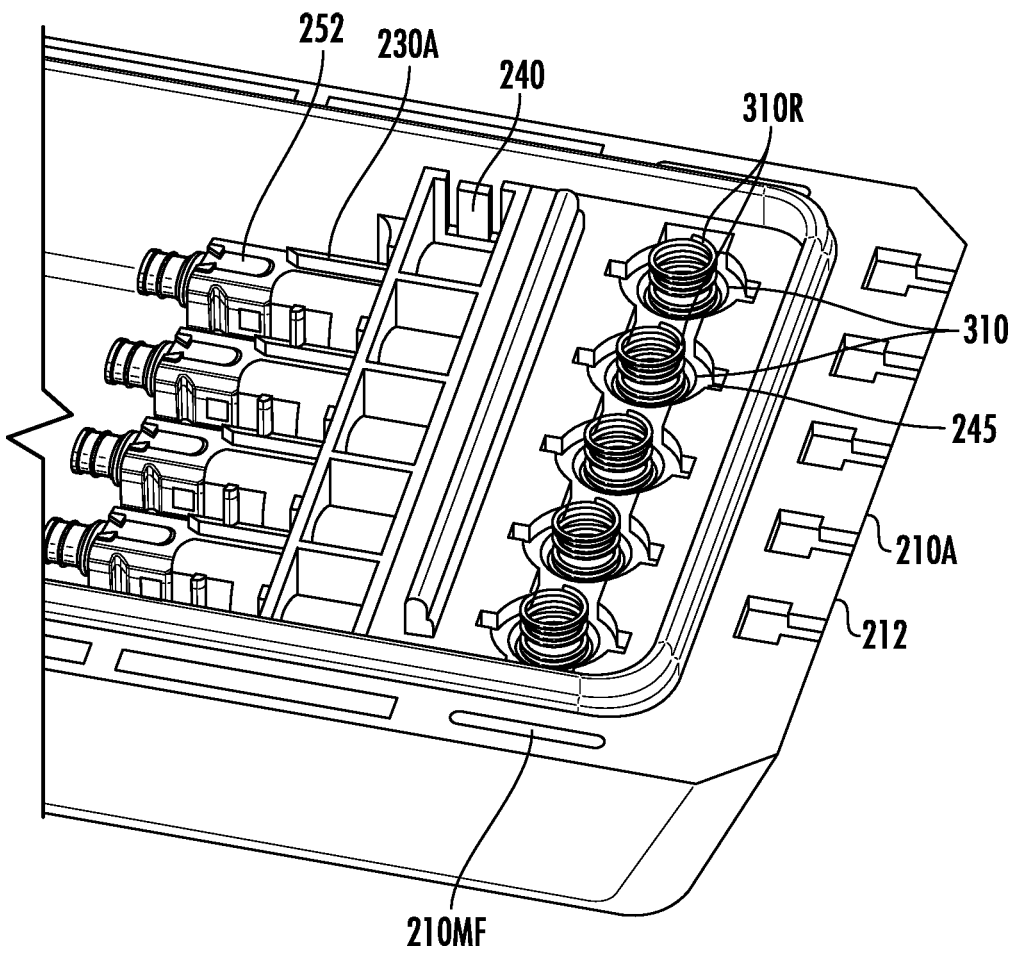

FIG. 26

32/85

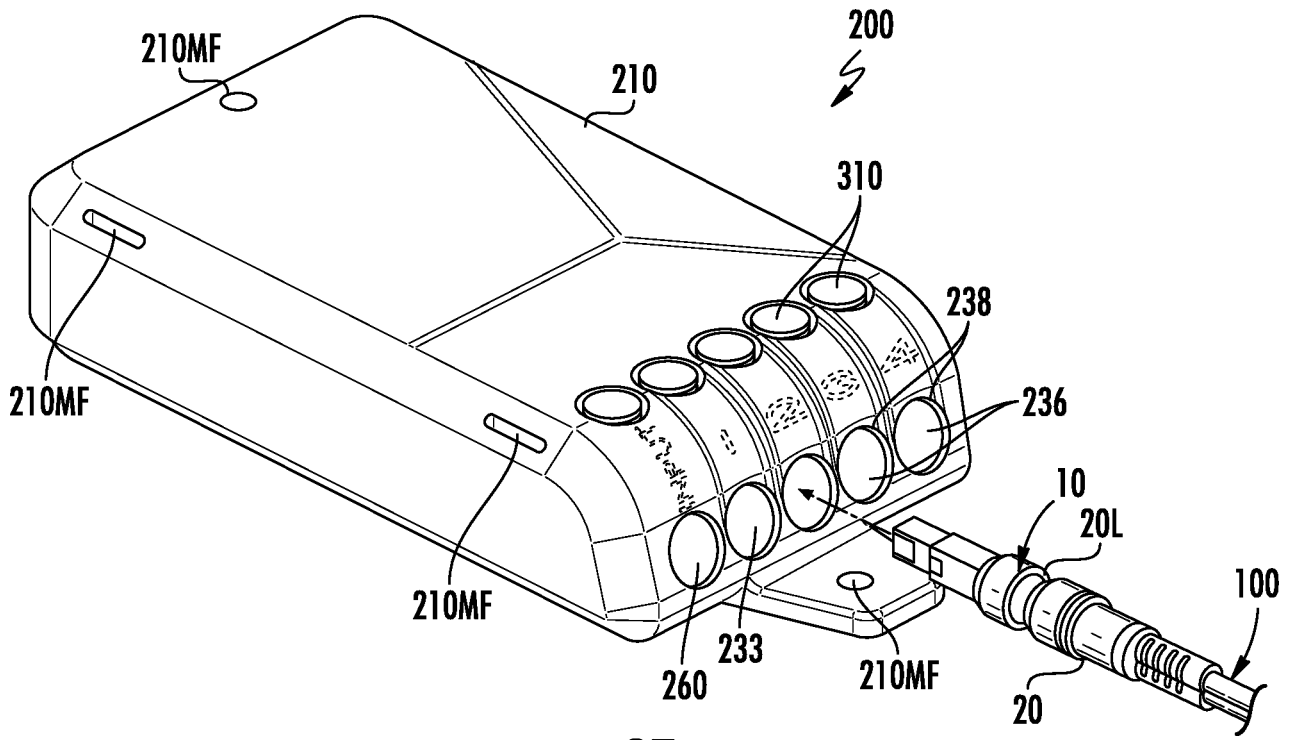

FIG. 27

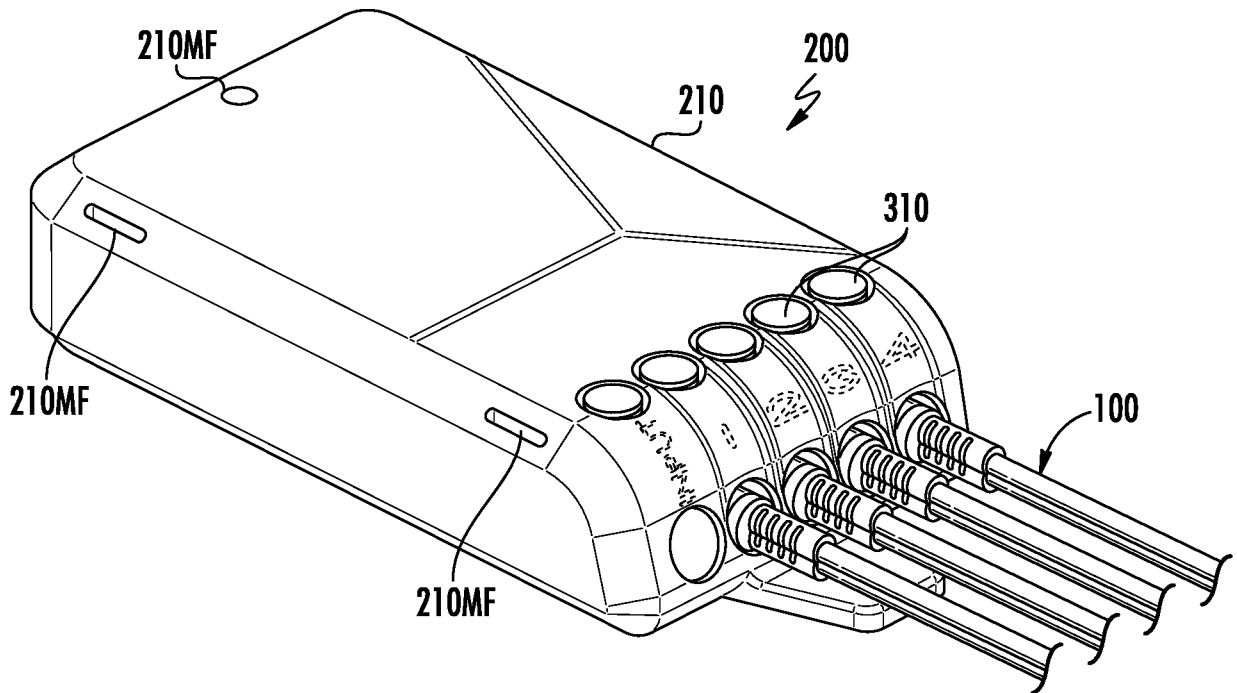

FIG. 28

33/85

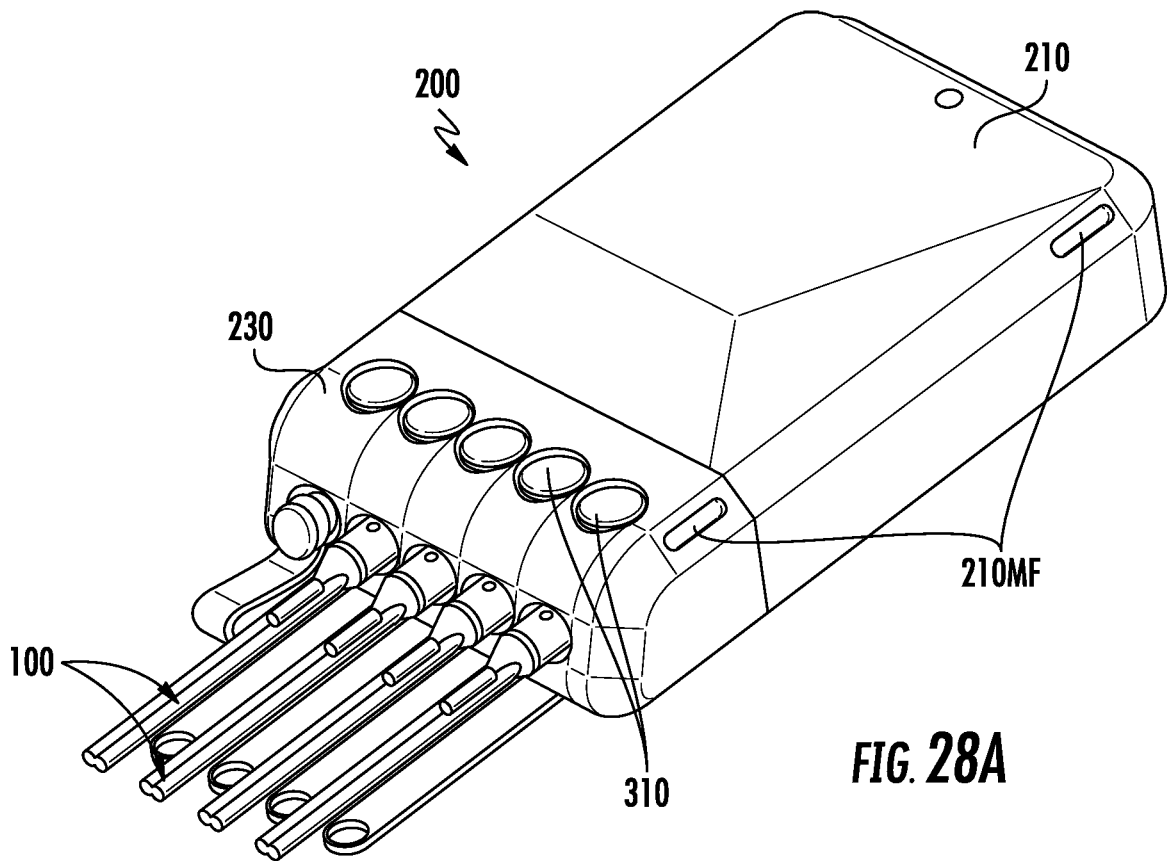

FIG. 28A

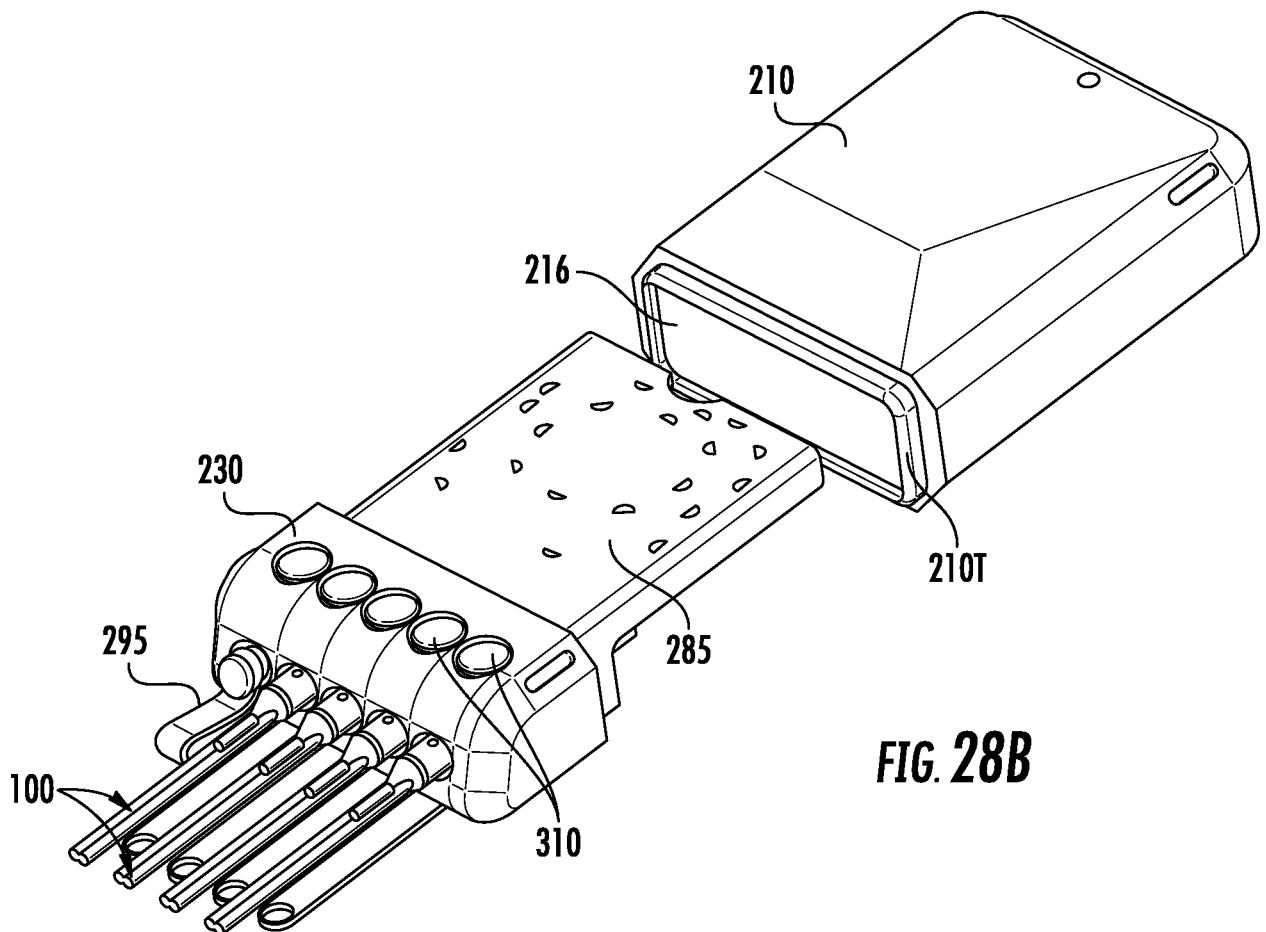

FIG. 28B

34/85

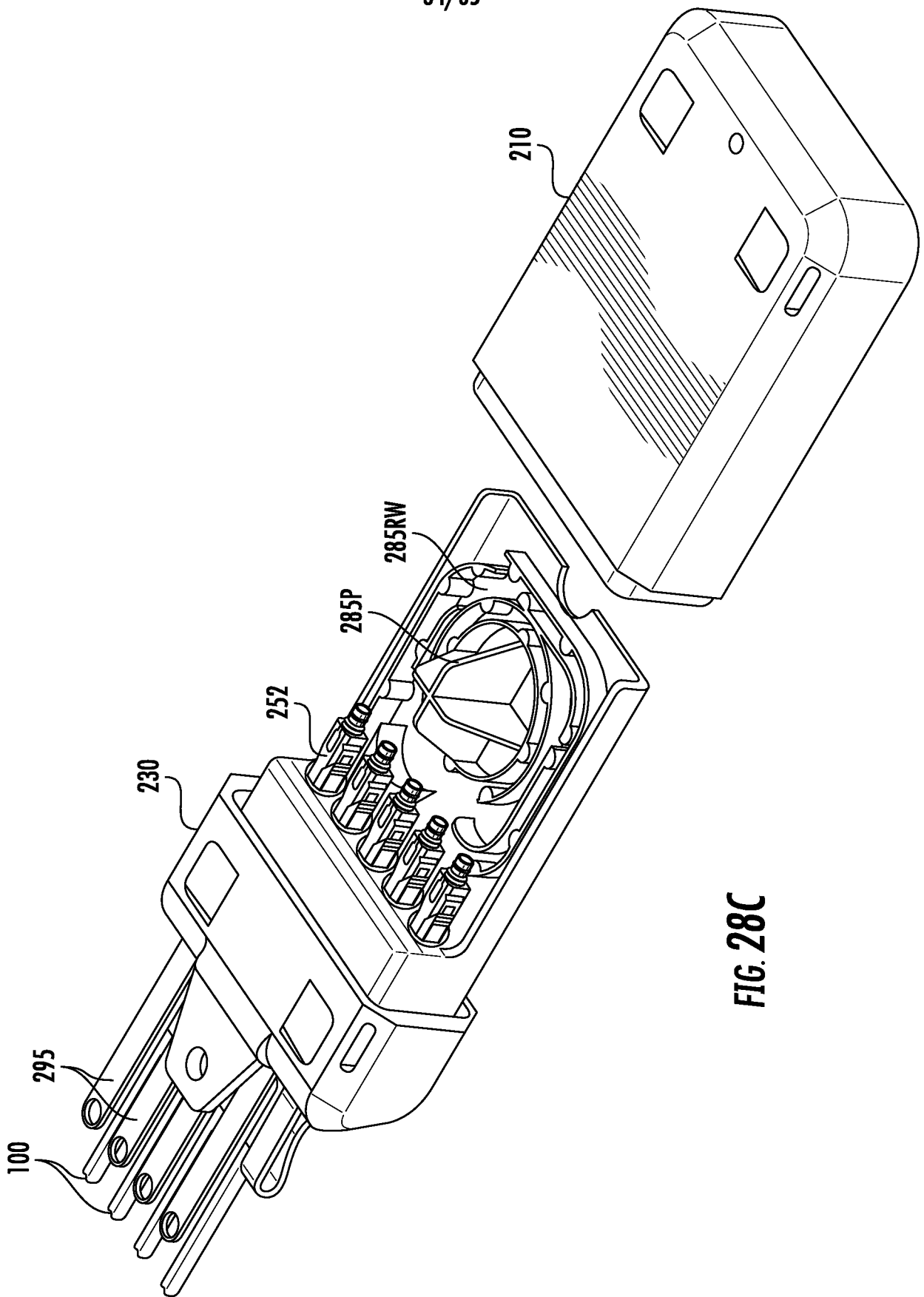

FIG. 28C

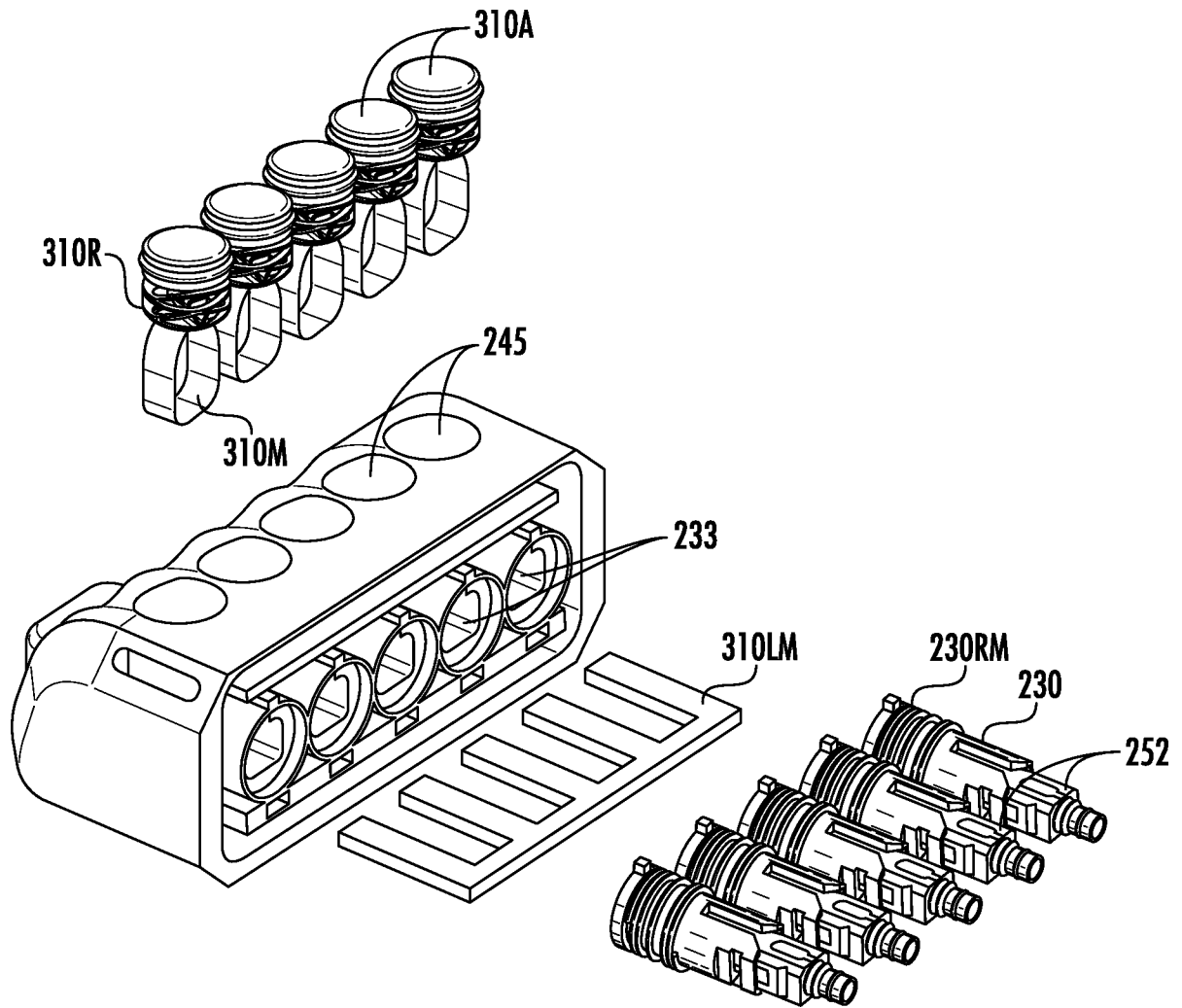

FIG. 28D

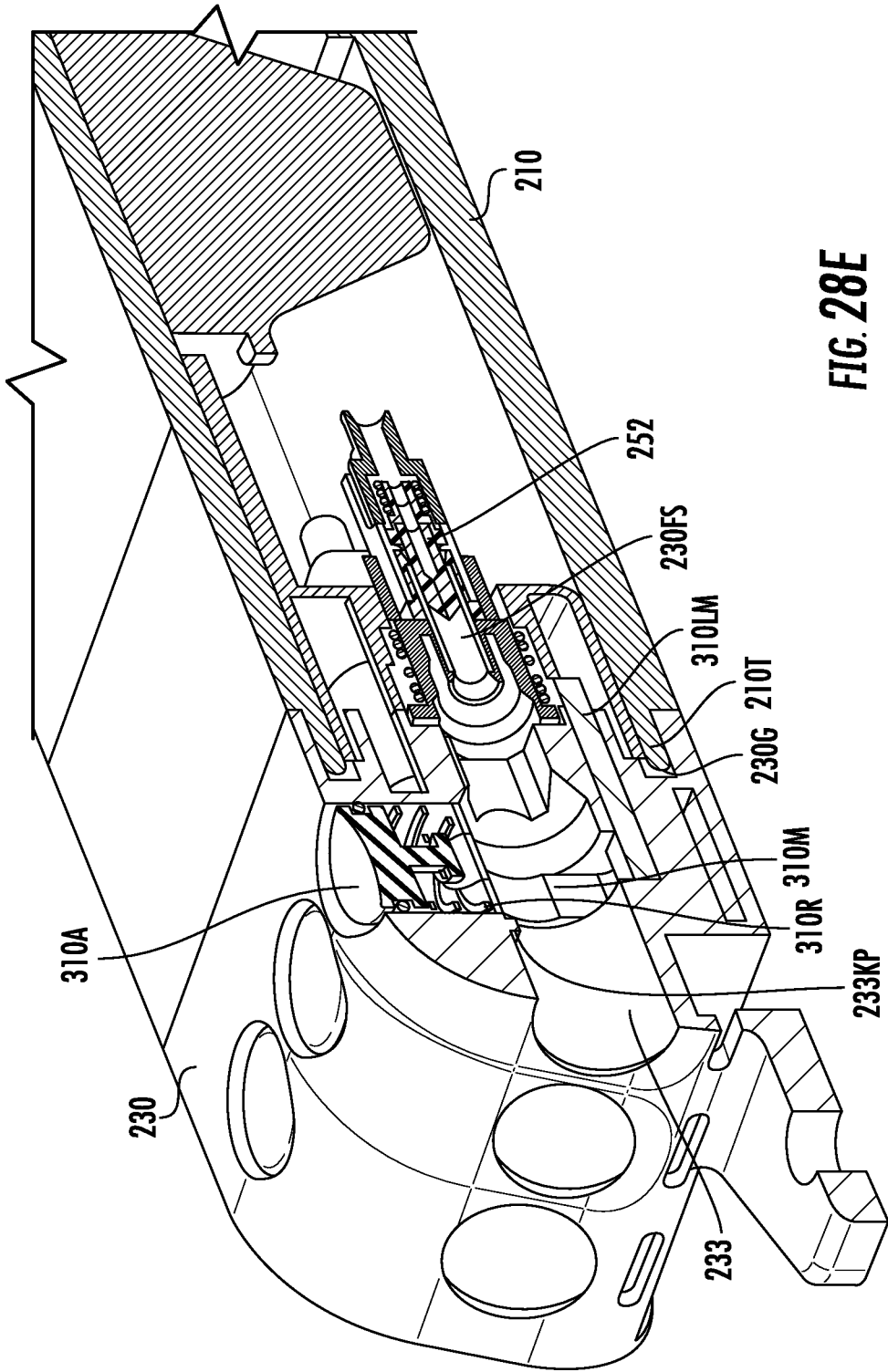

FIG. 28E

37/85

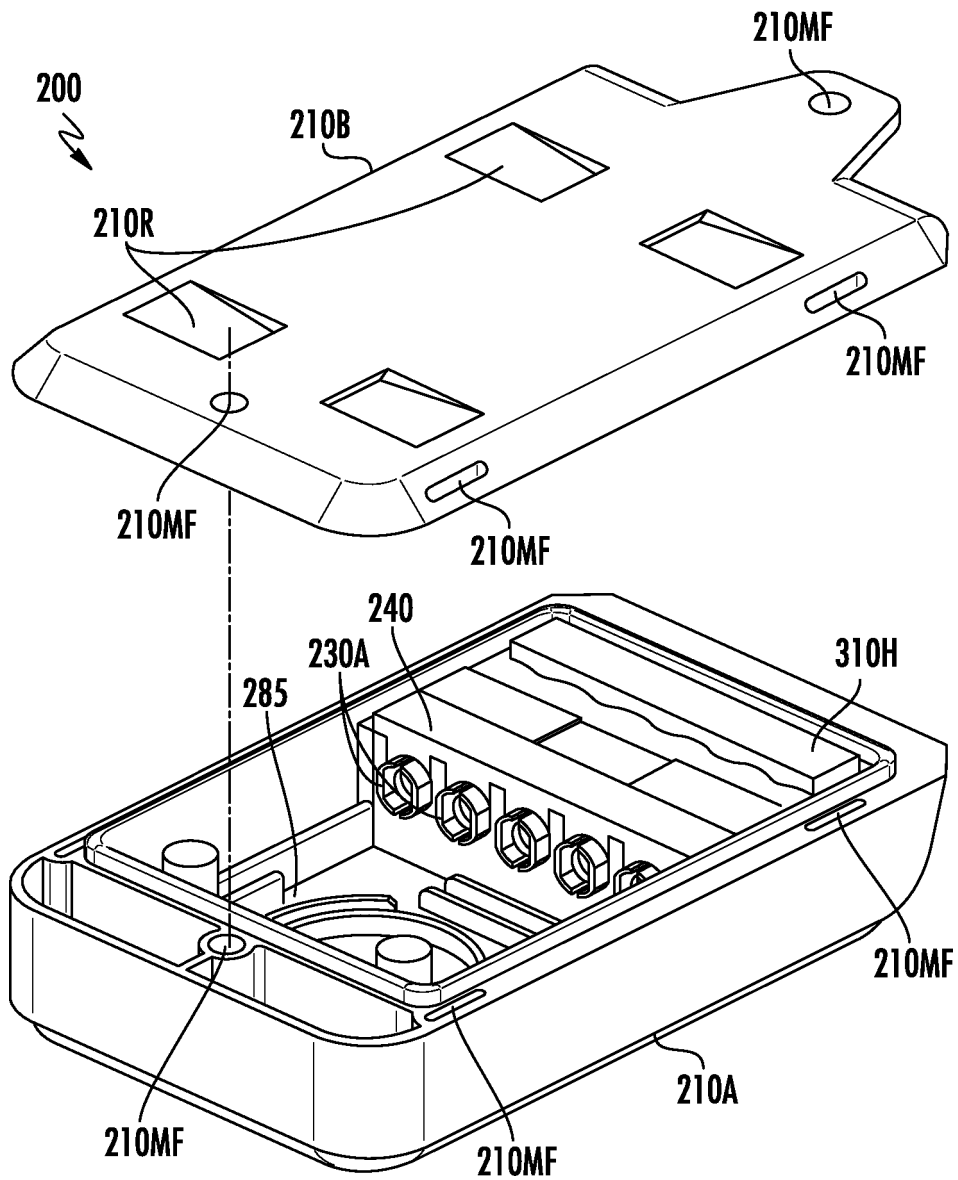

FIG. 29

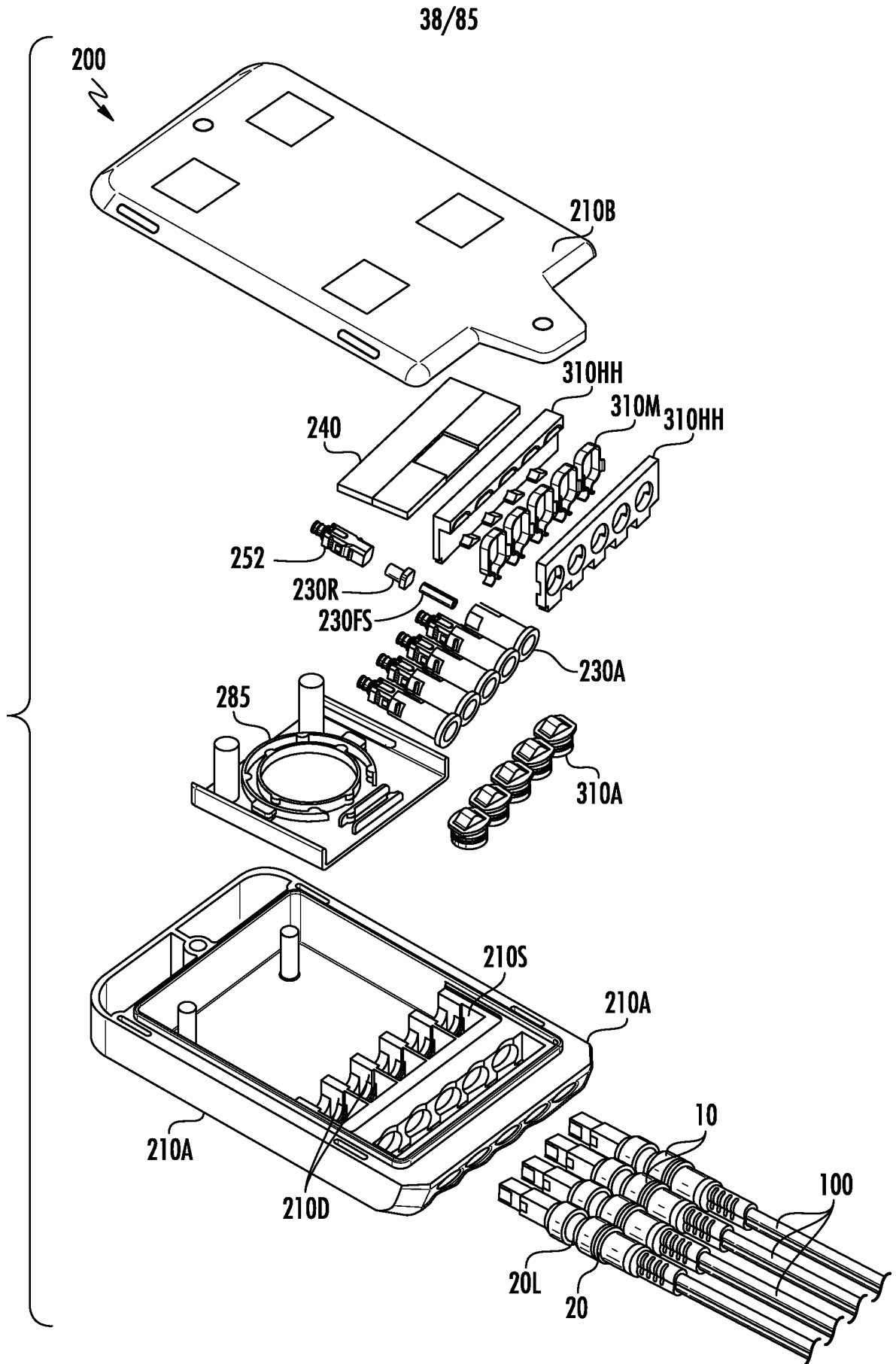

FIG. 30

39/85

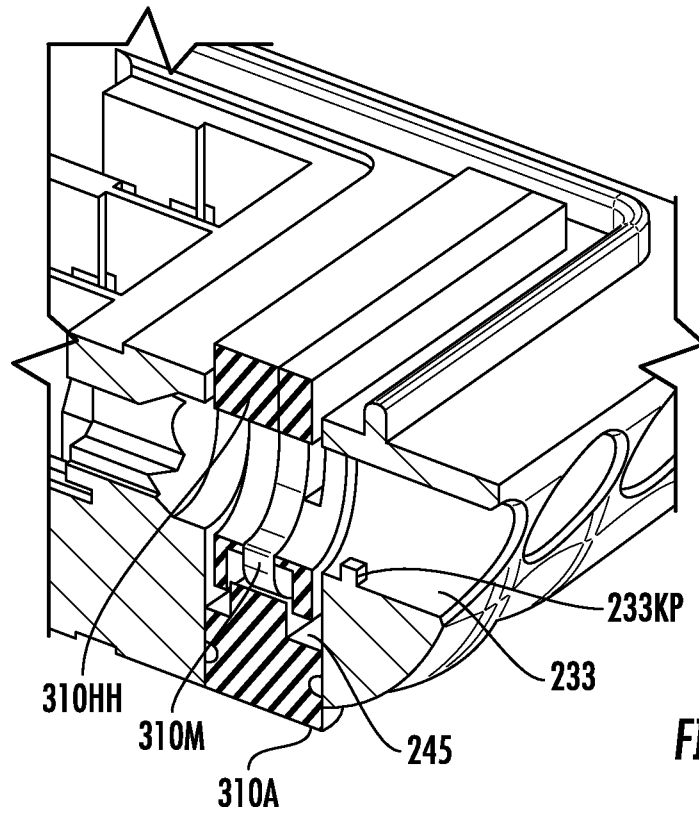

FIG. 31

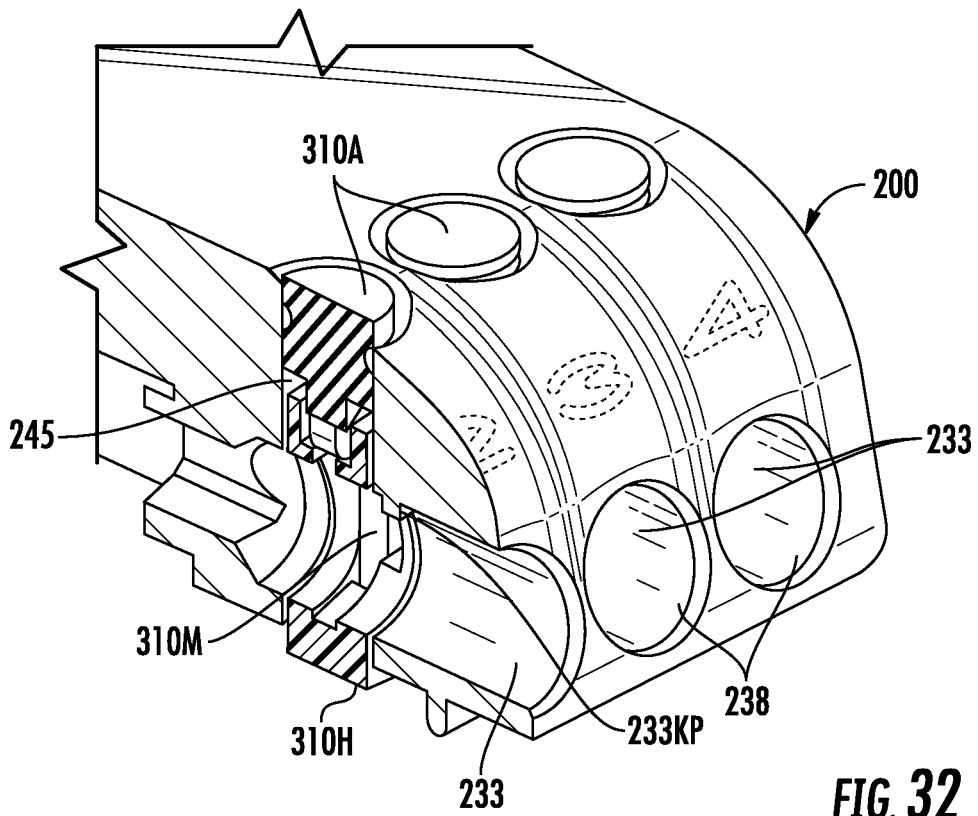

FIG. 32

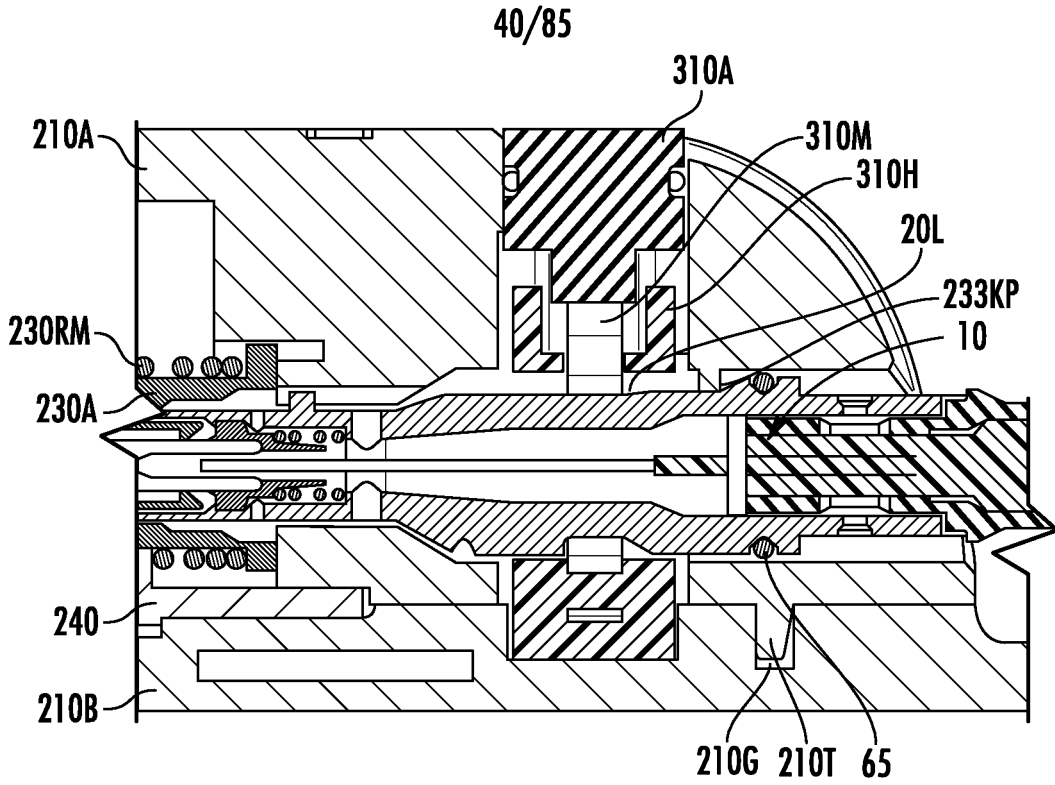

FIG. 33

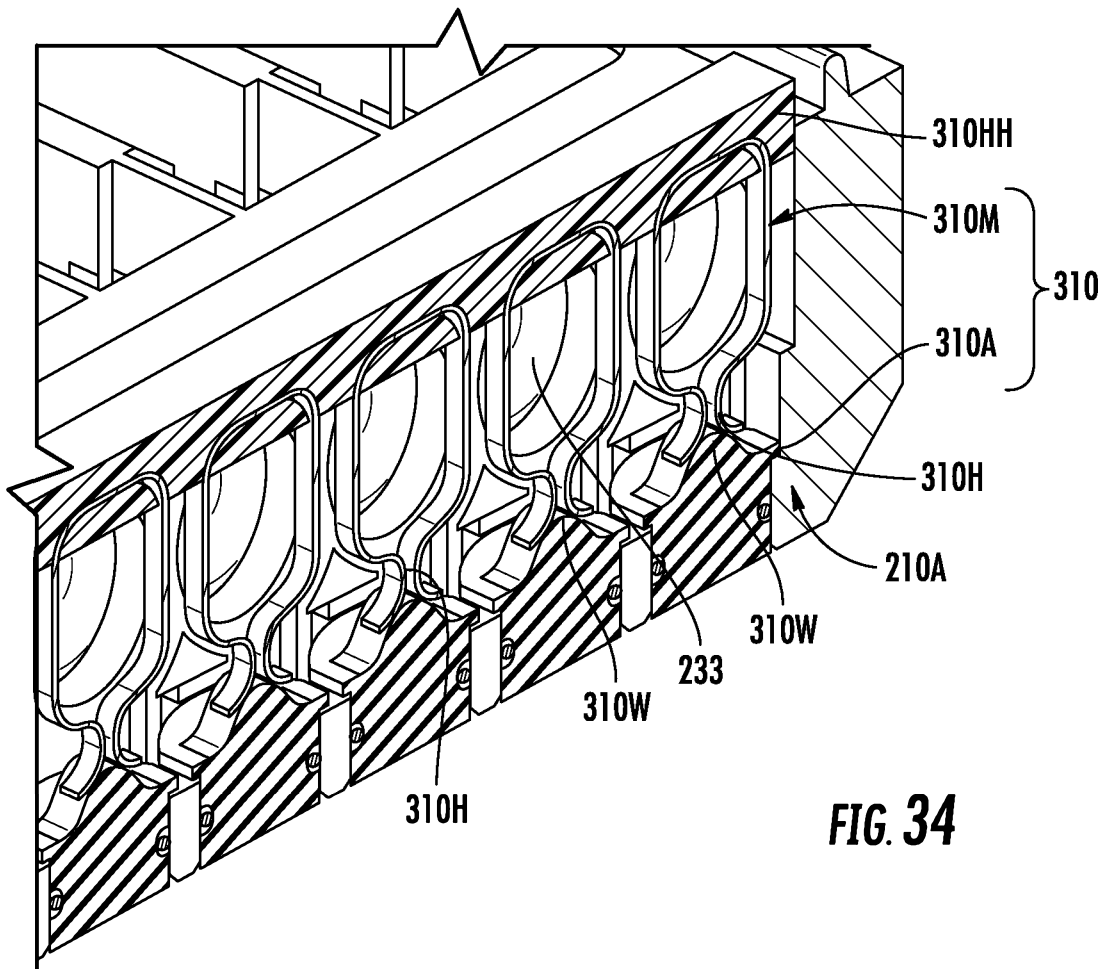

FIG. 34

41/85

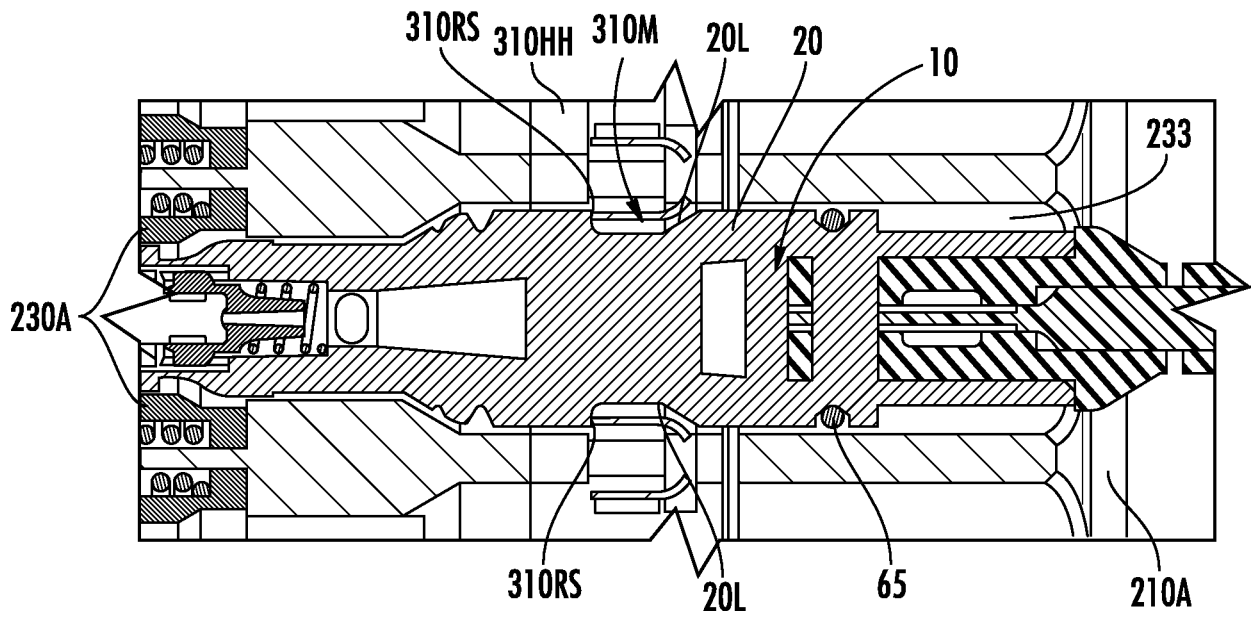

FIG. 35

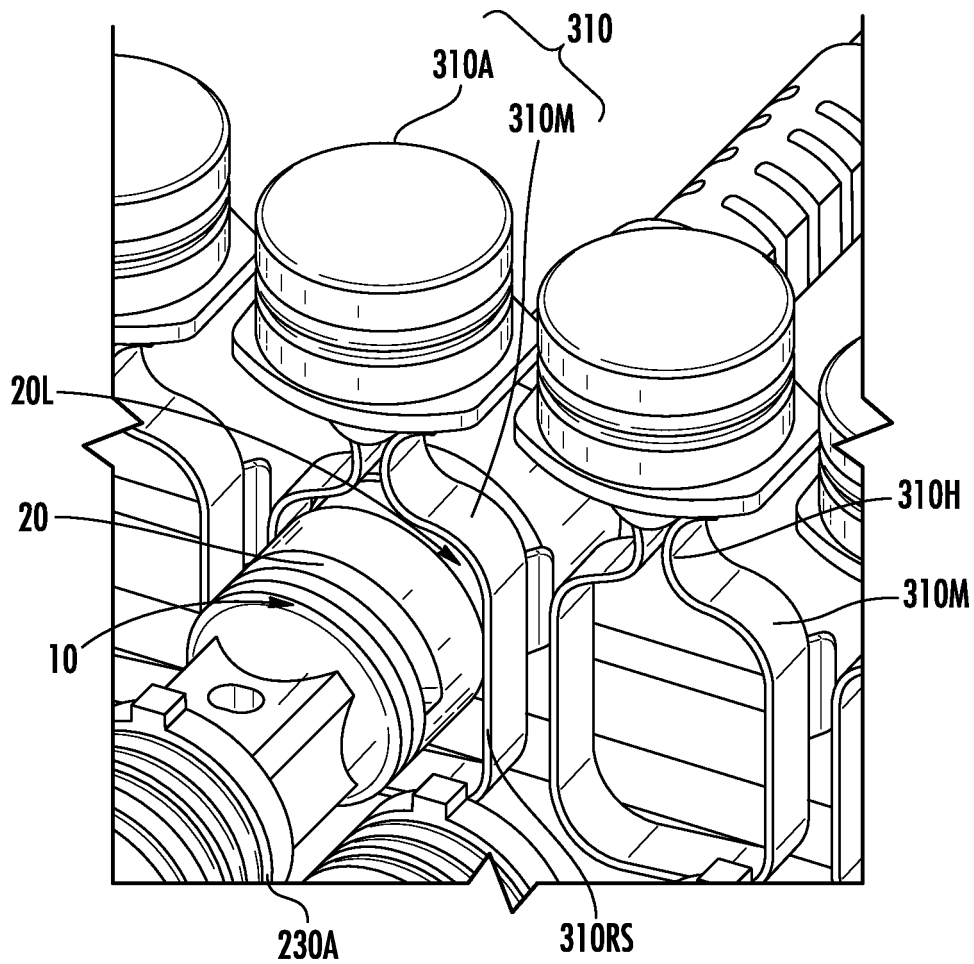

FIG. 36

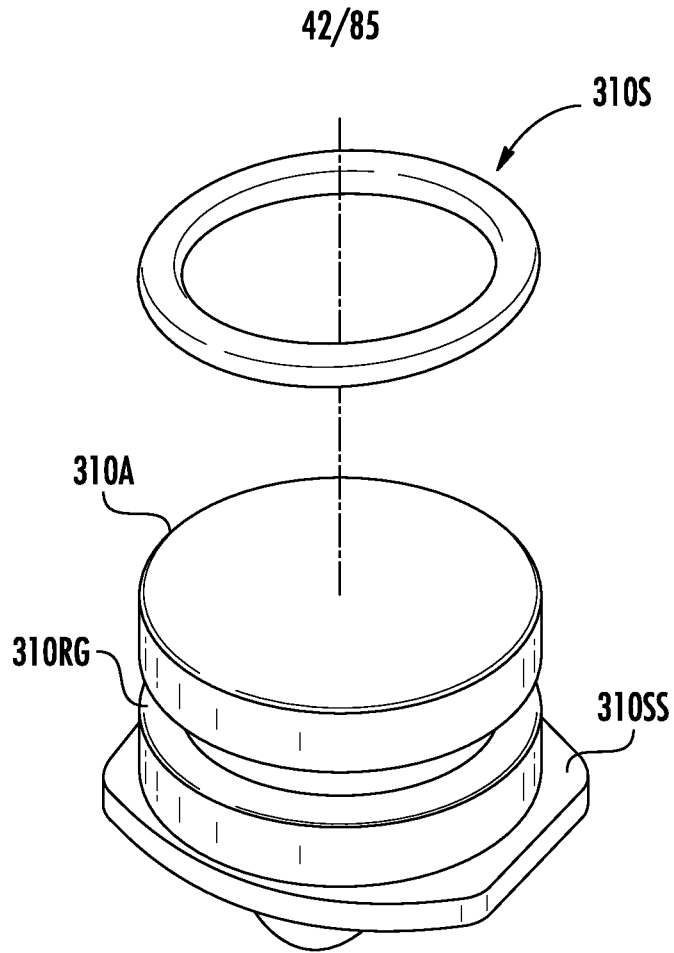

FIG. 37

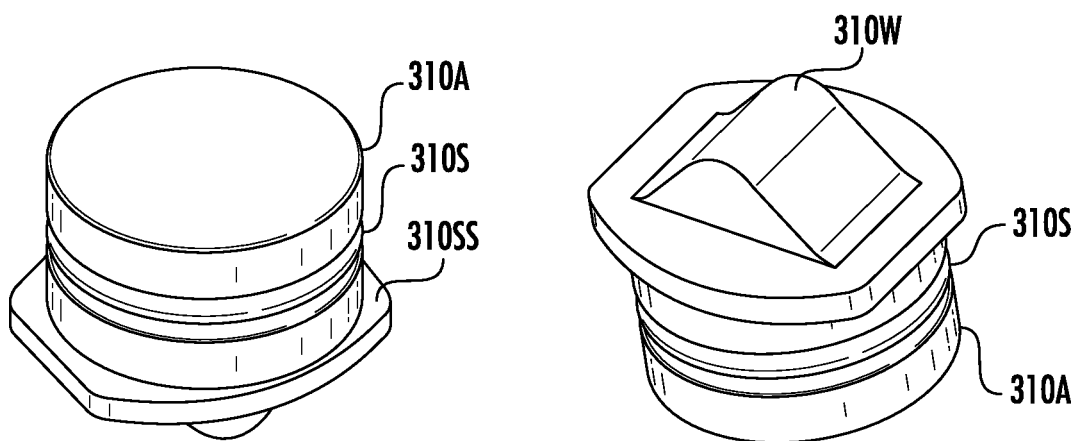

FIG. 38

FIG. 39

43/85

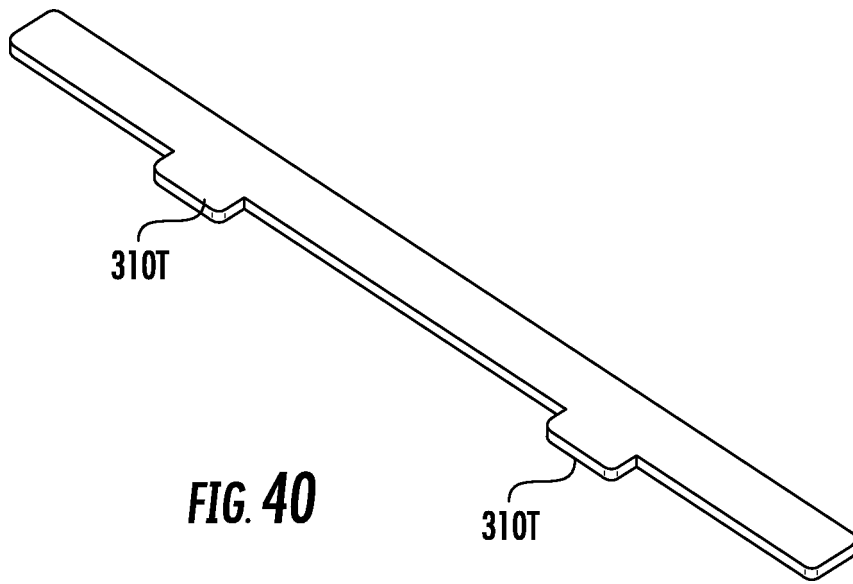

FIG. 40

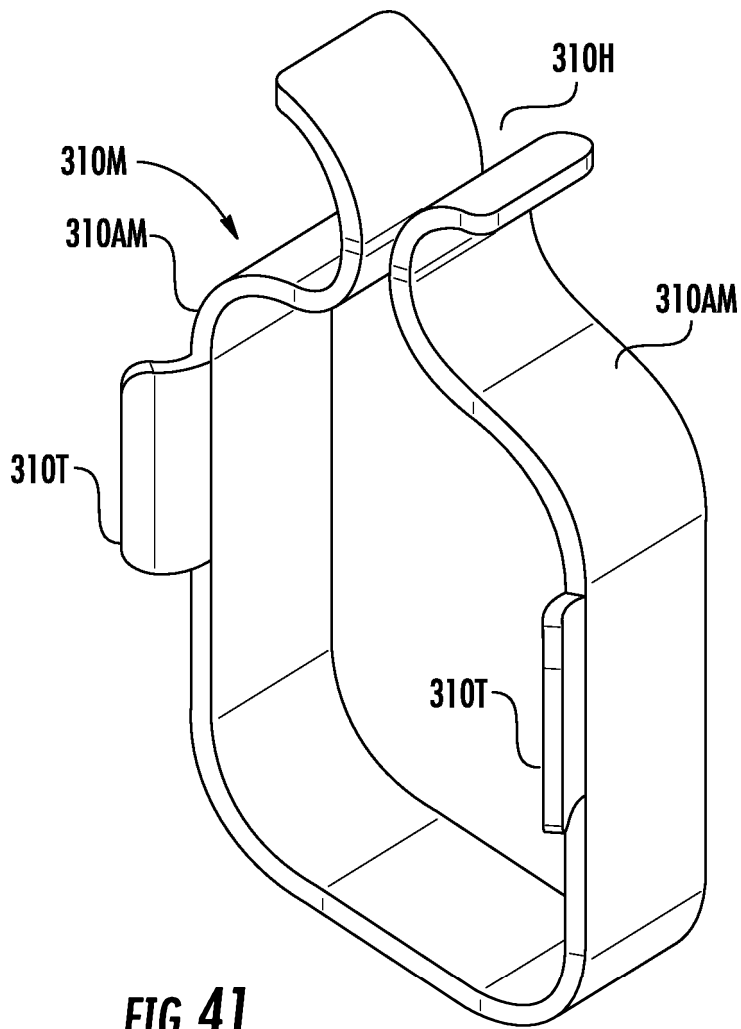

FIG. 41

44/85

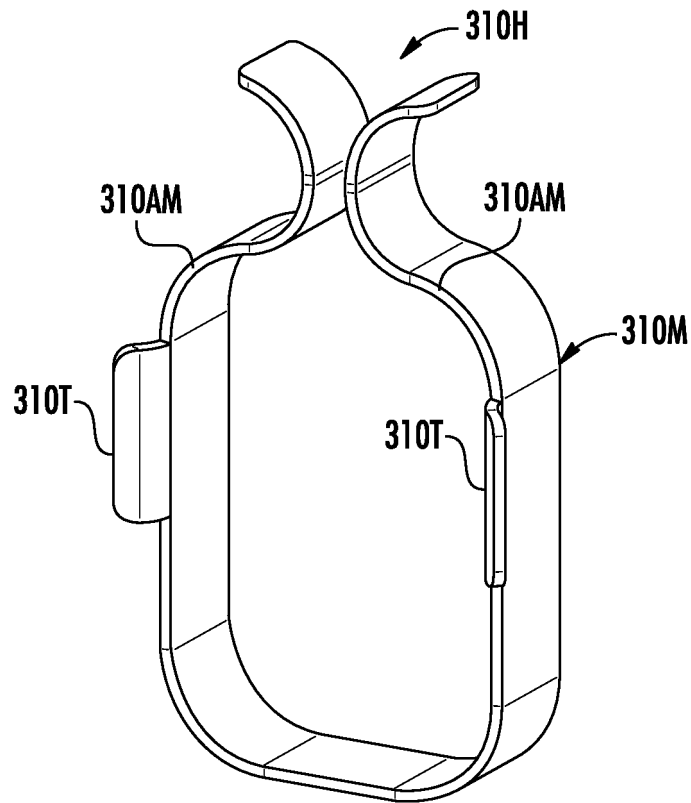

FIG. 42

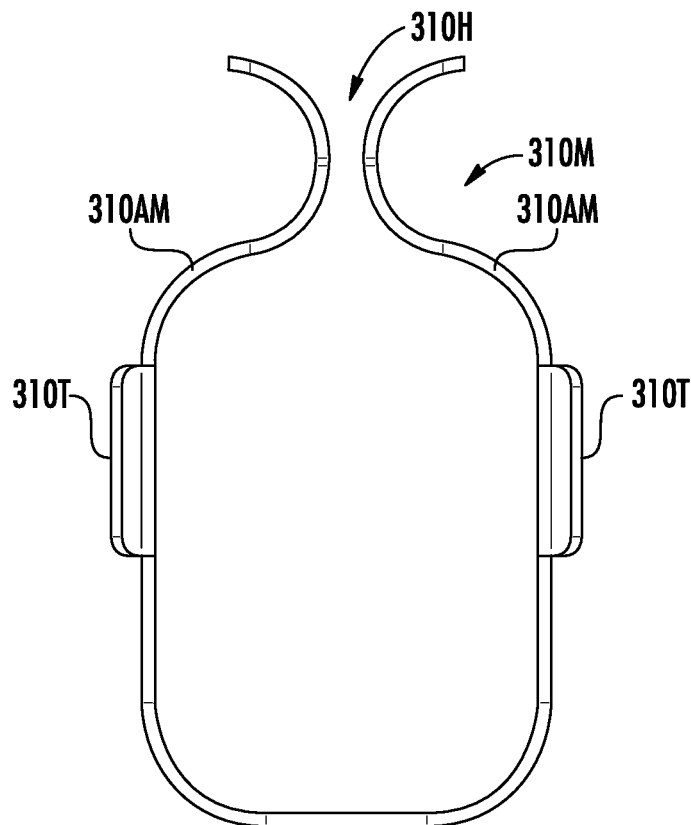

FIG. 43

45/85

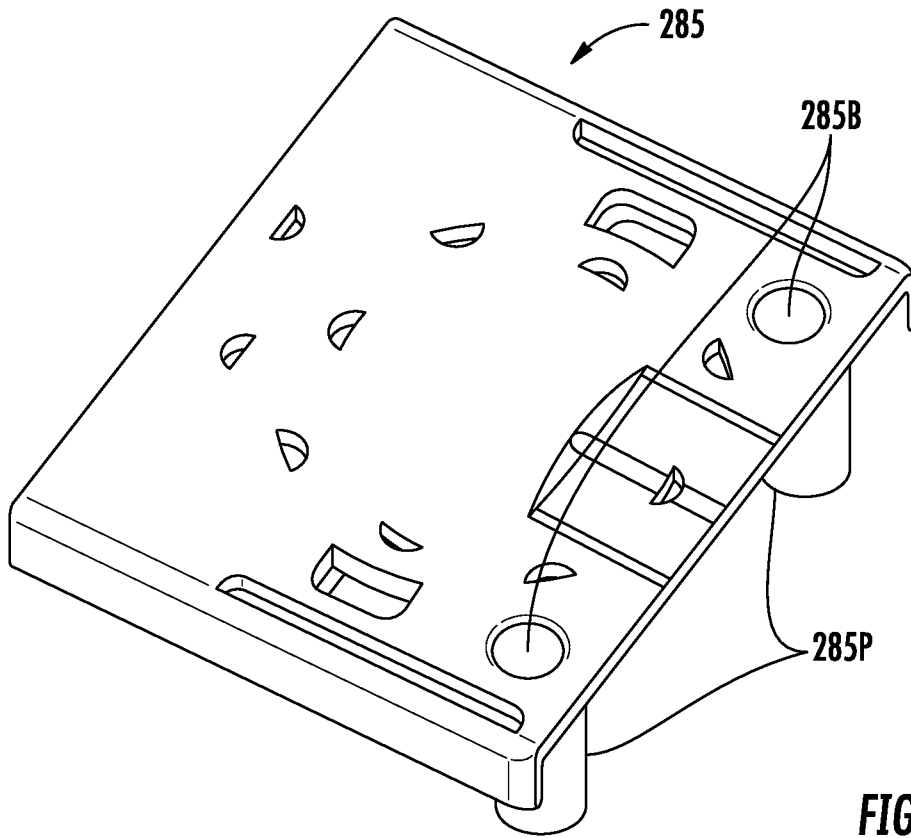

FIG. 44

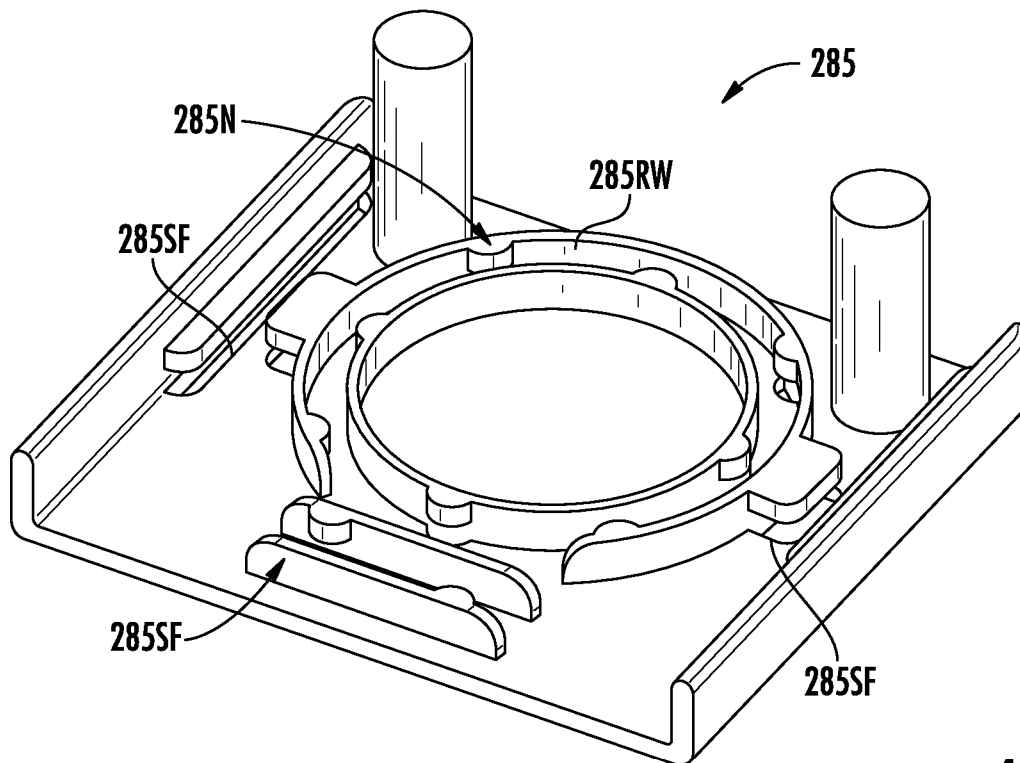

FIG. 45

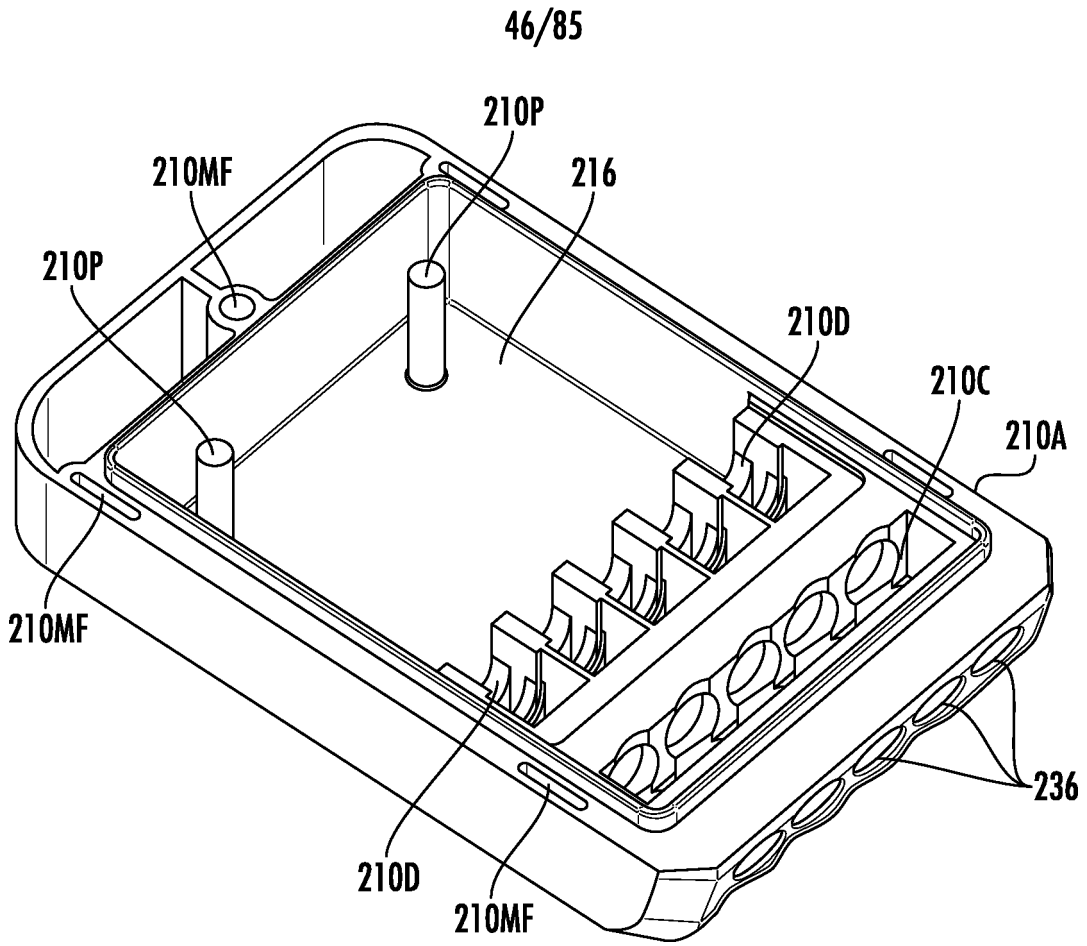

FIG. 46

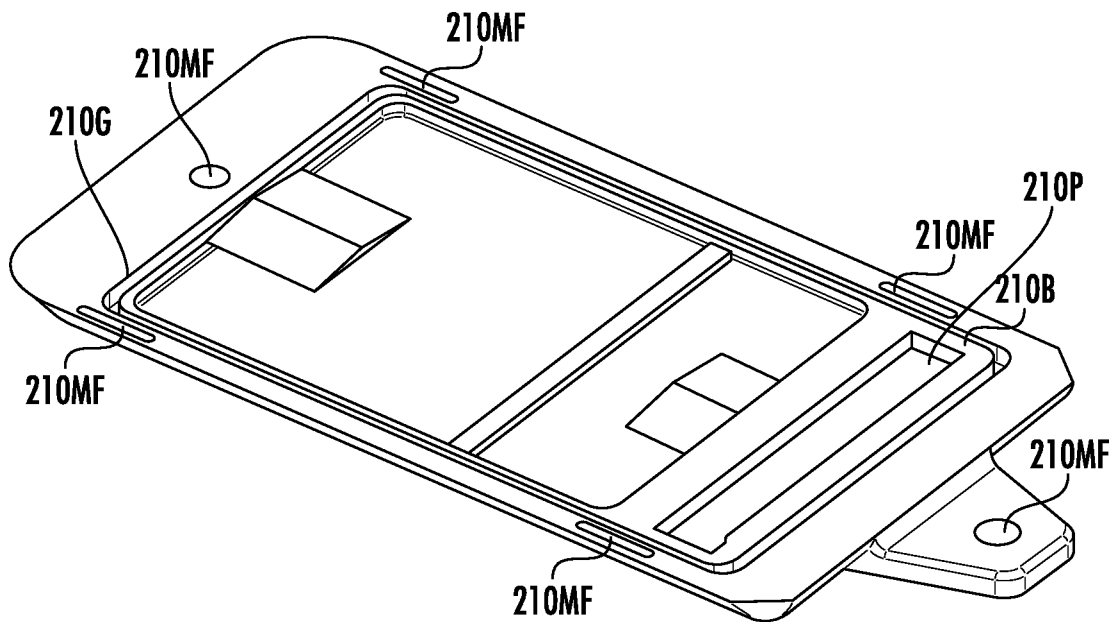

FIG. 47

47/85

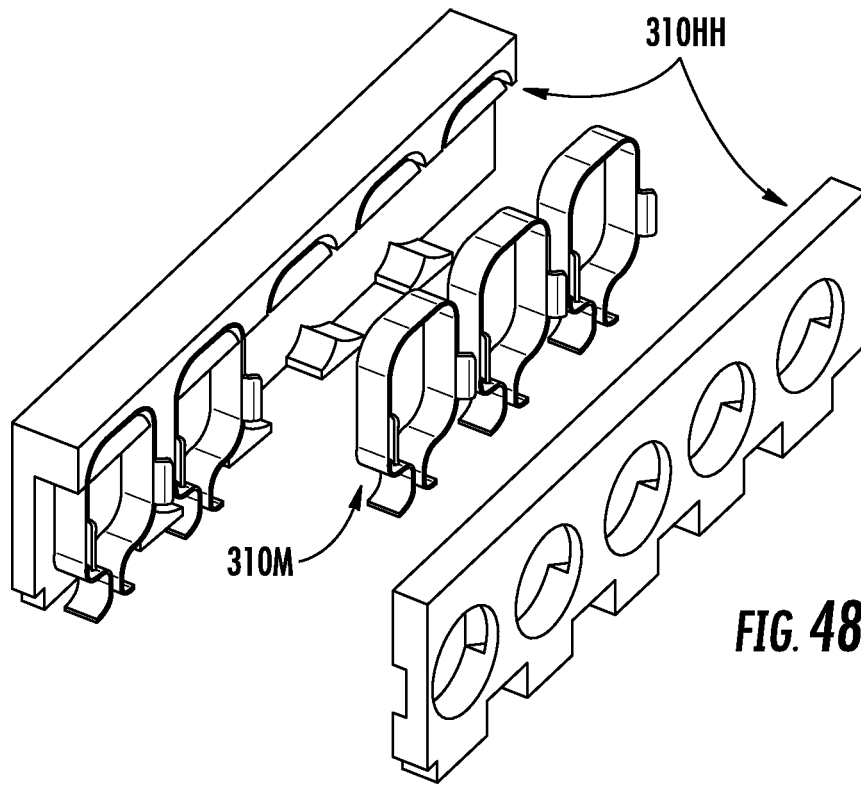

FIG. 48

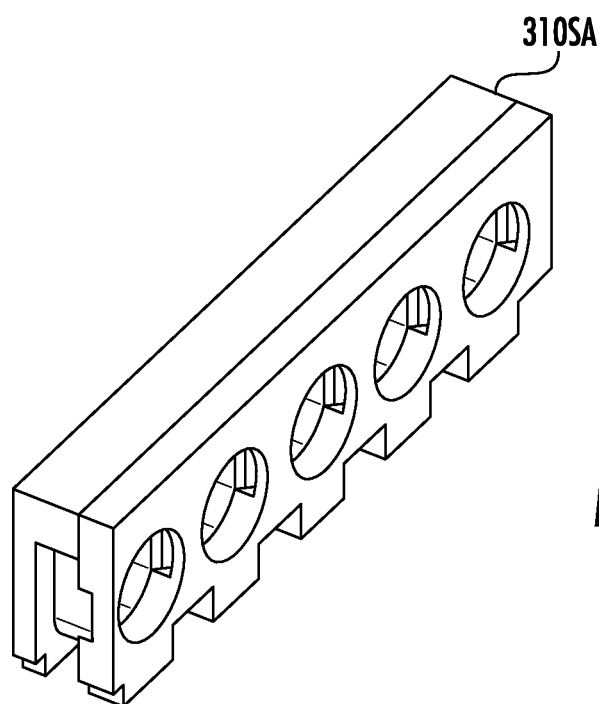

FIG. 49

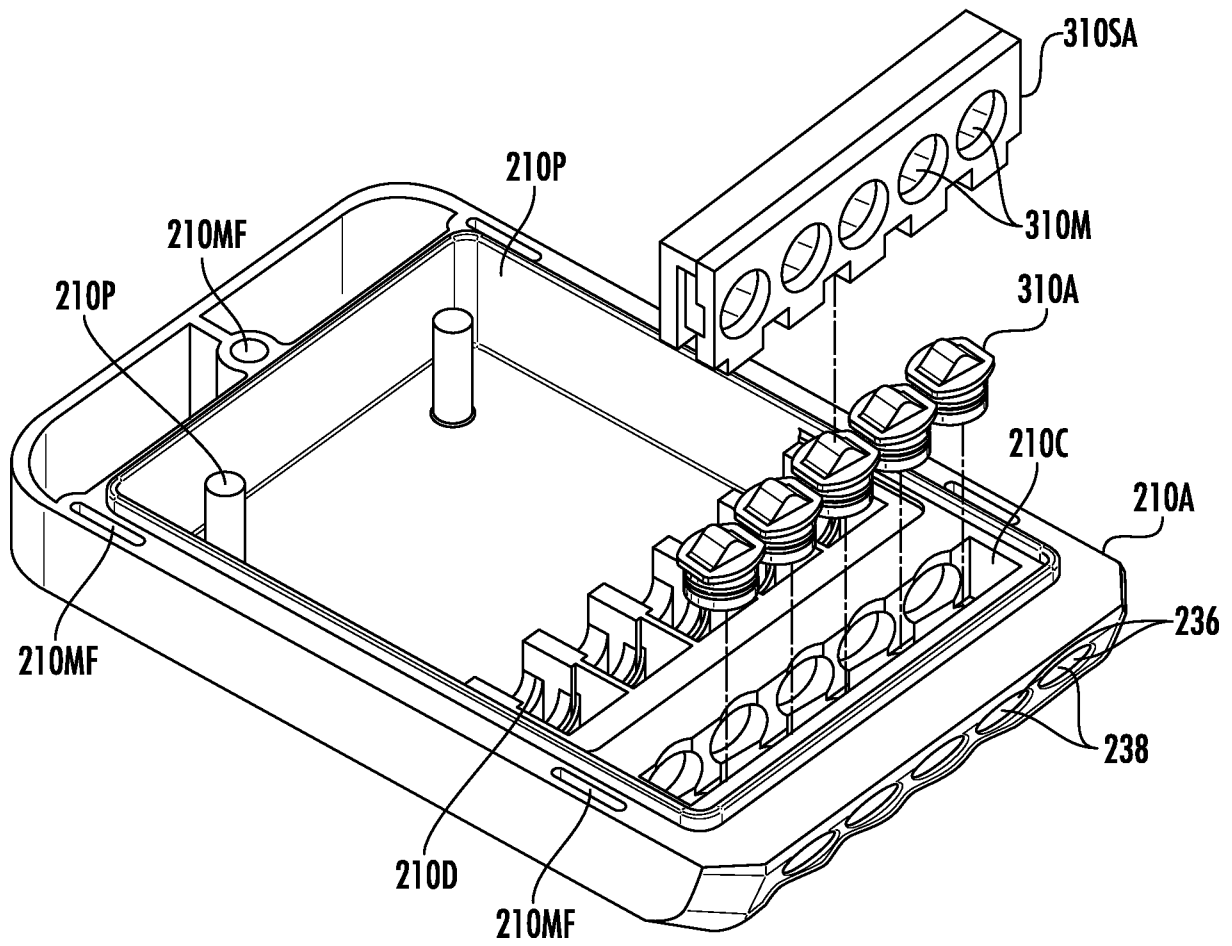

FIG. 50

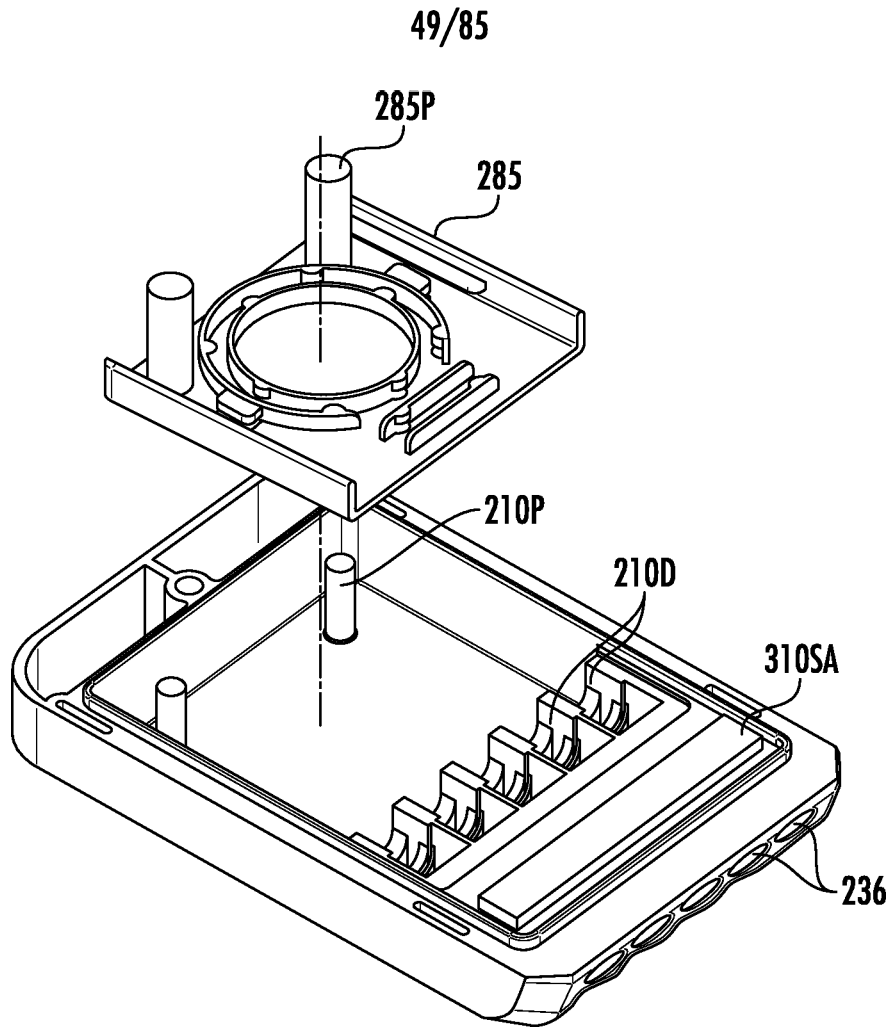

FIG. 51

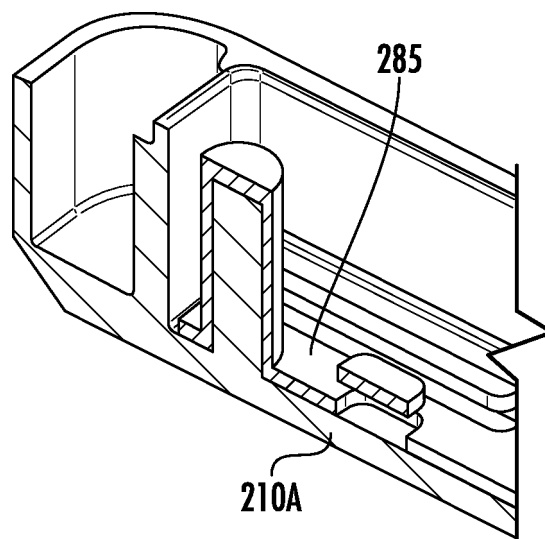

FIG. 52

50/85

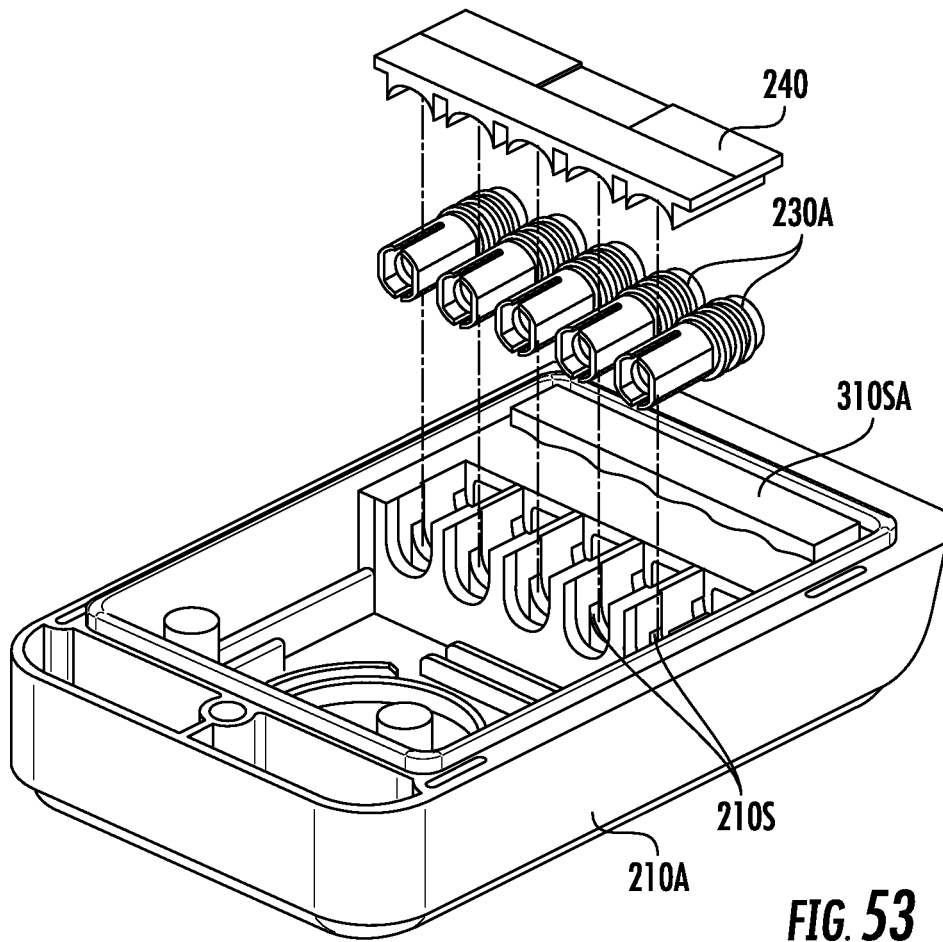

FIG. 53

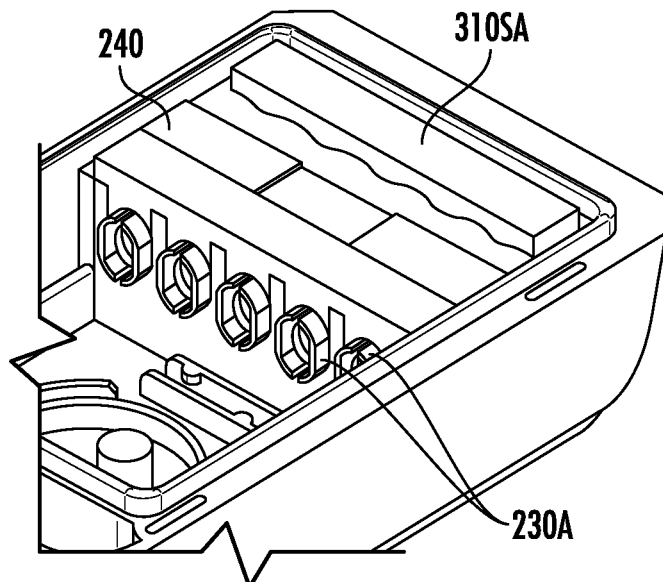

FIG. 54

51/85

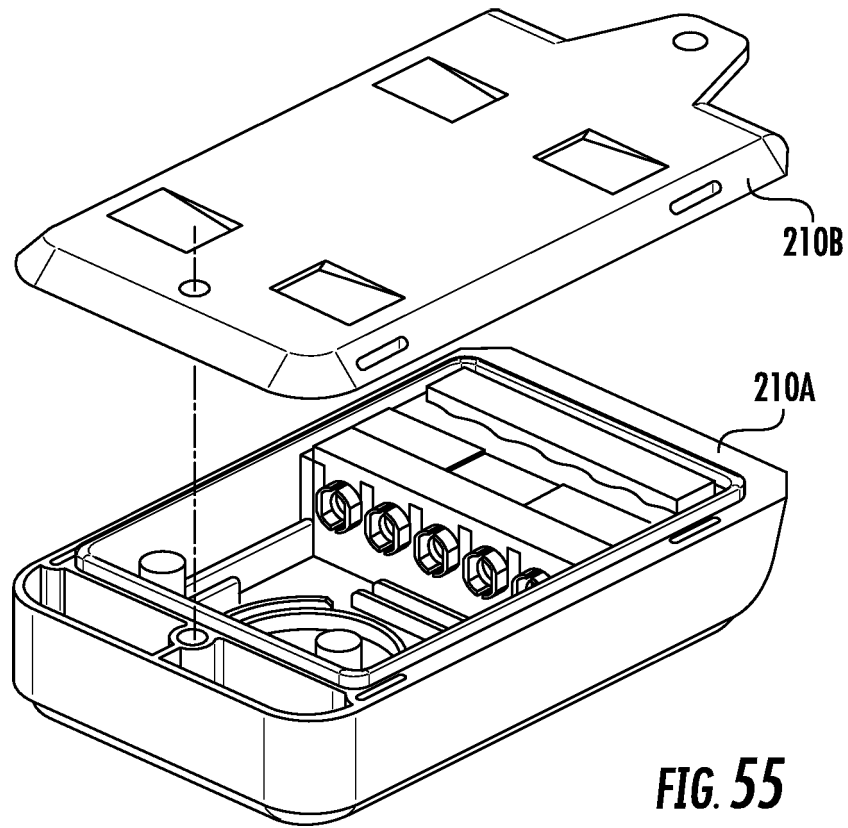

FIG. 55

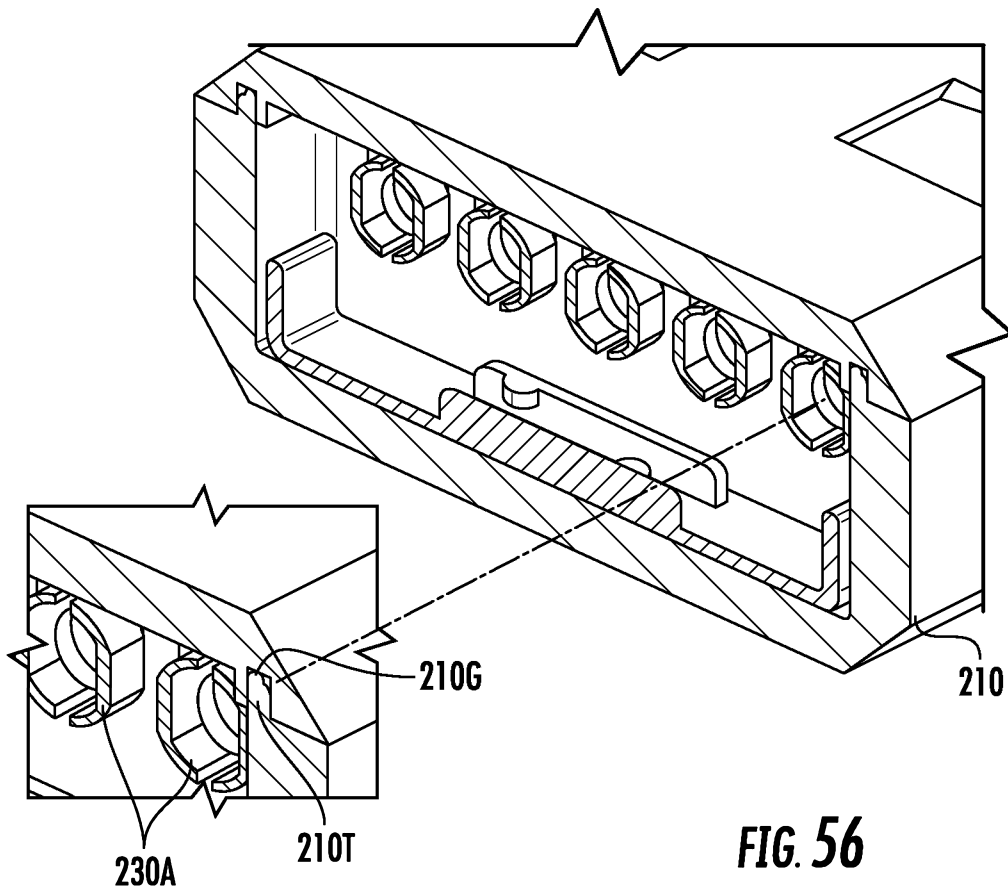

FIG. 56

52/85

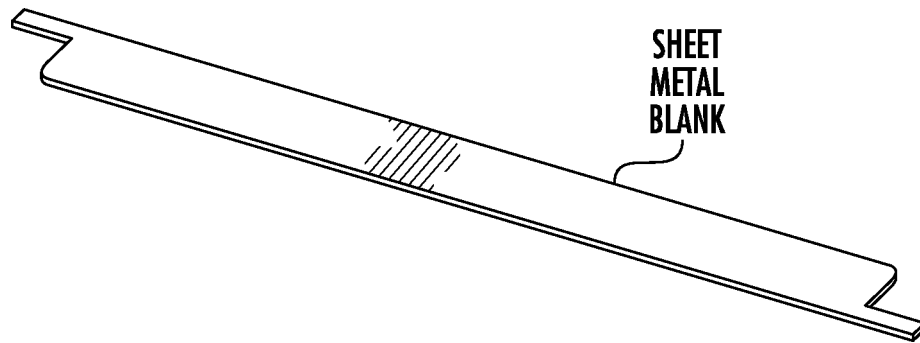

FIG. 57

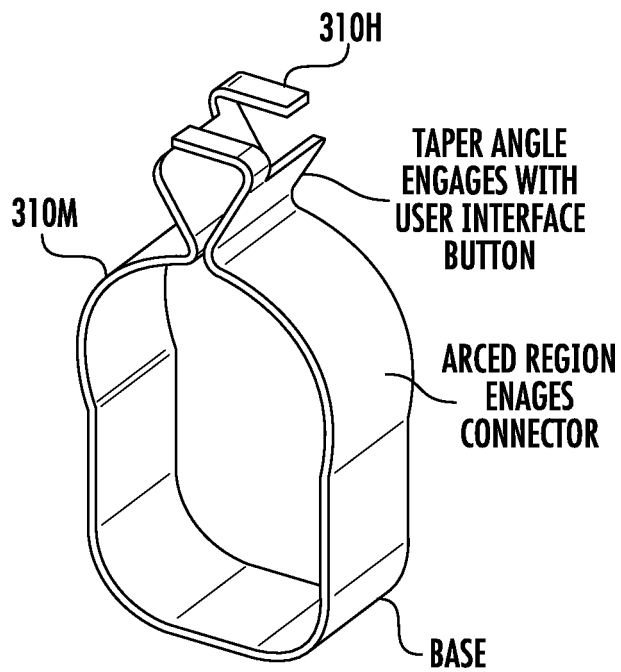

FIG. 58

53/85

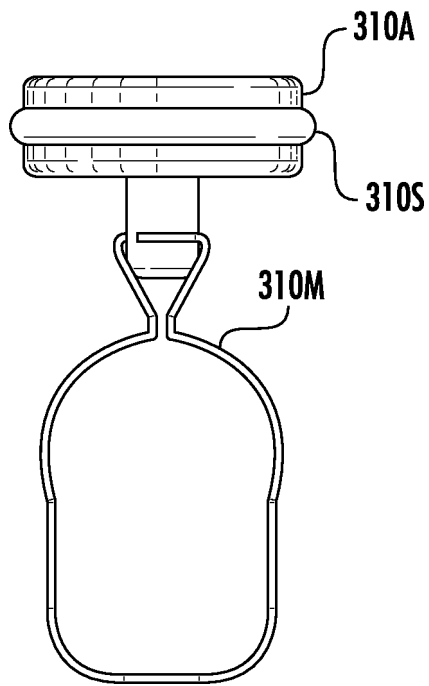

FIG. 59

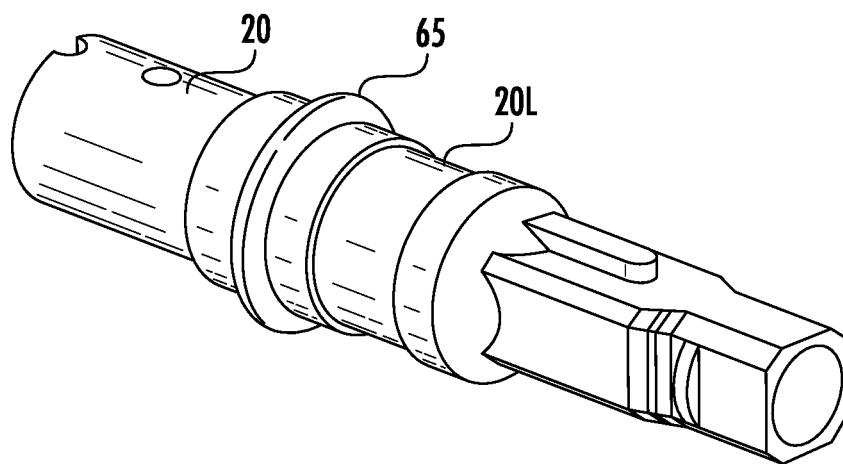

FIG. 60

54/85

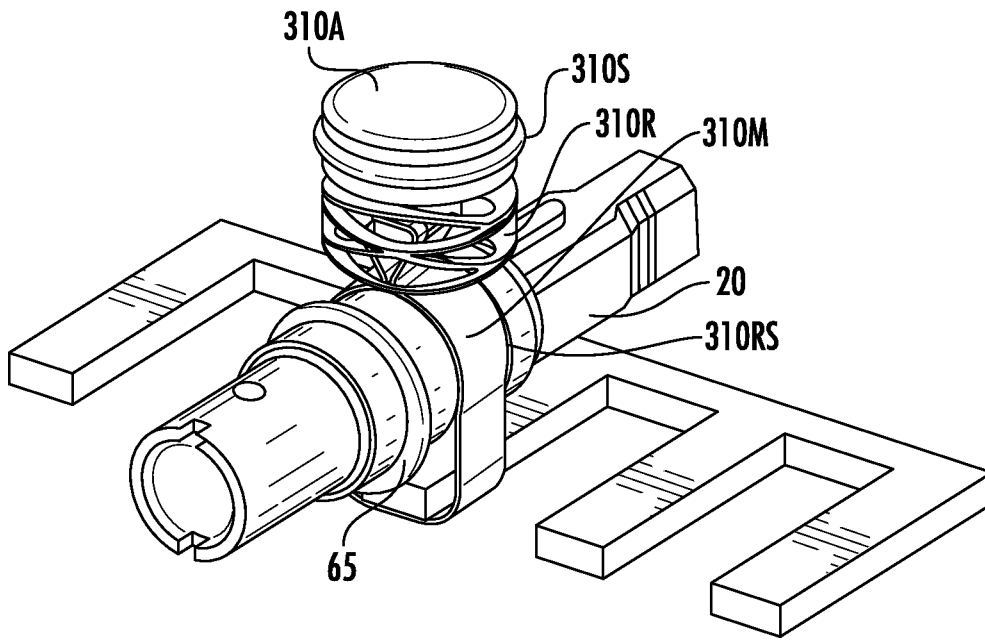

FIG. 61

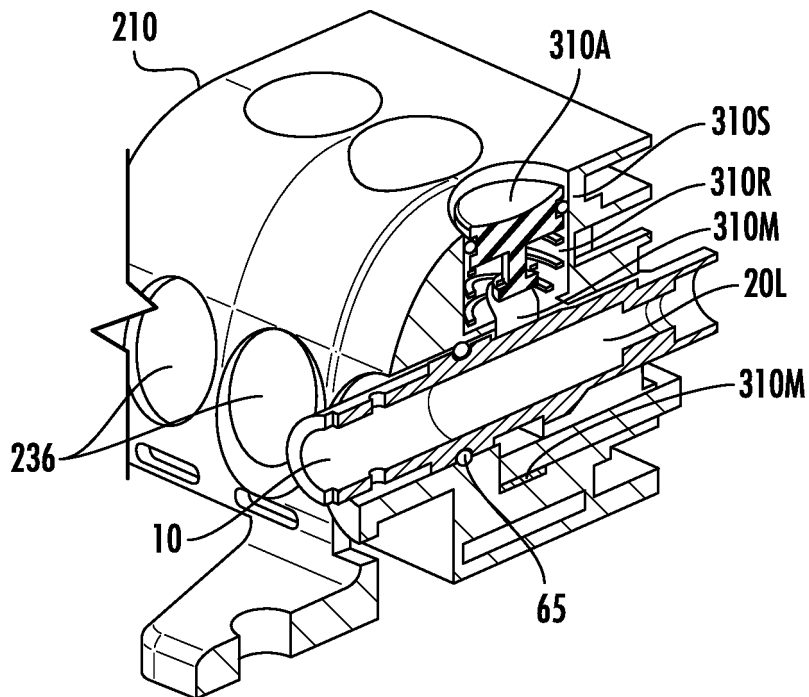

FIG. 62

55/85

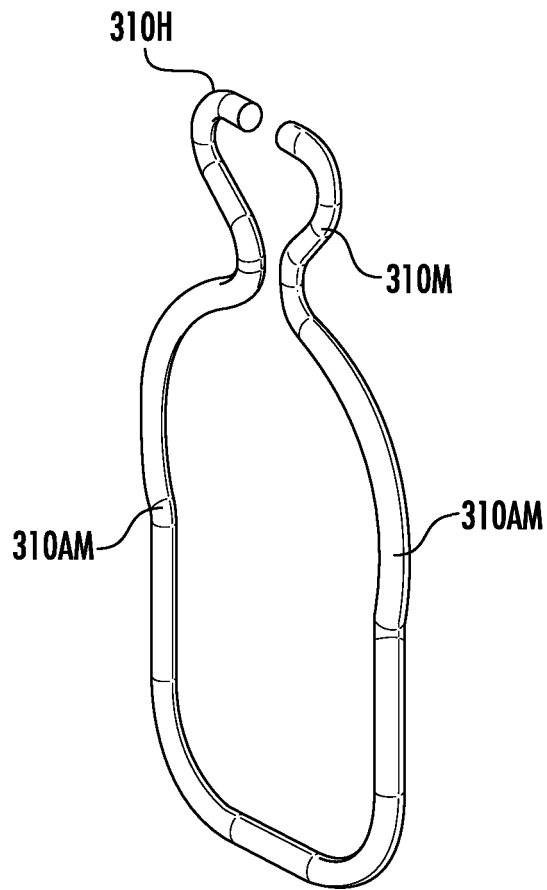

FIG. 63

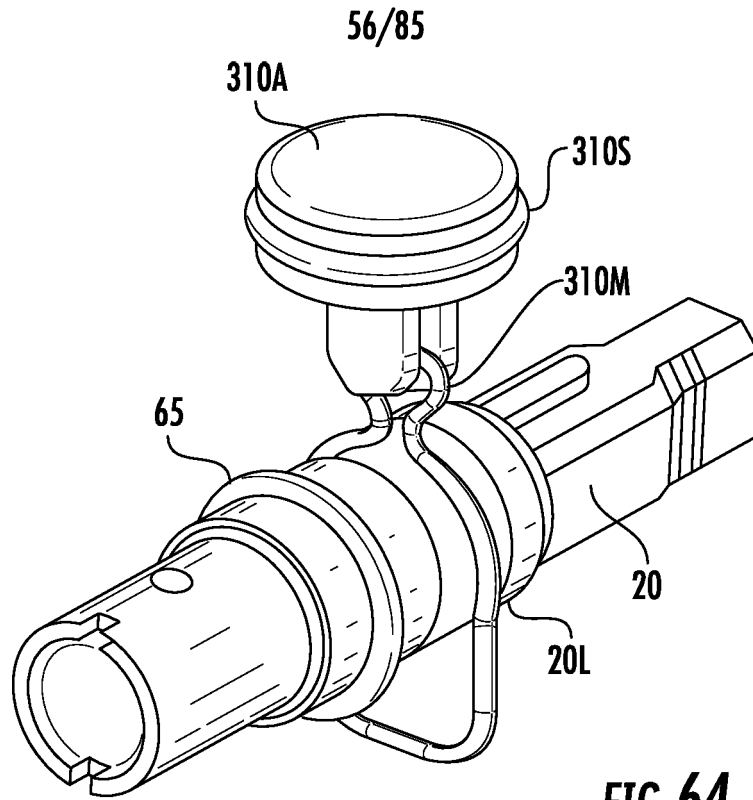

FIG. 64

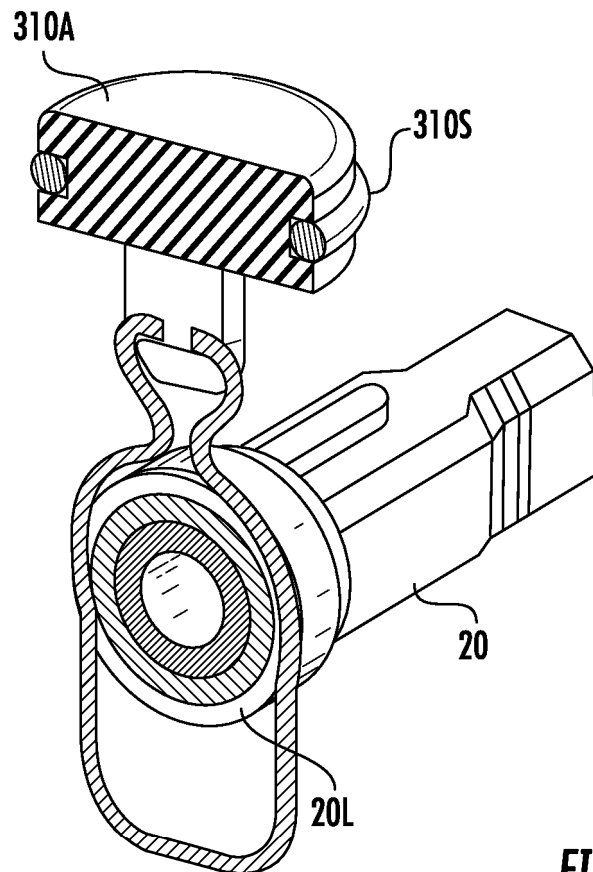

FIG. 65

57/85

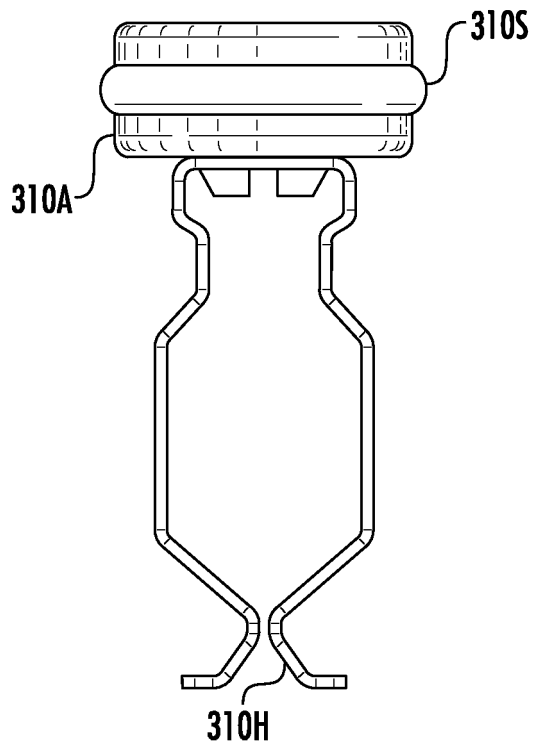

FIG. 66

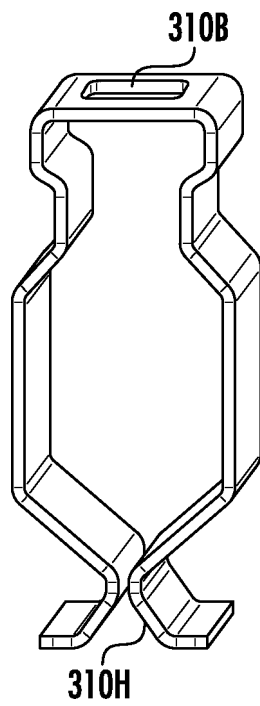

FIG. 67

58/85

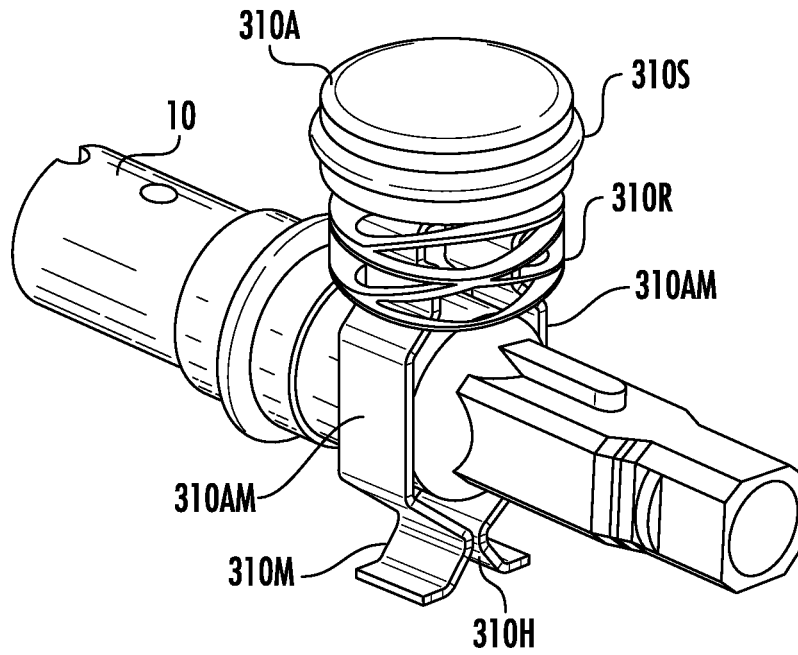

FIG. 68

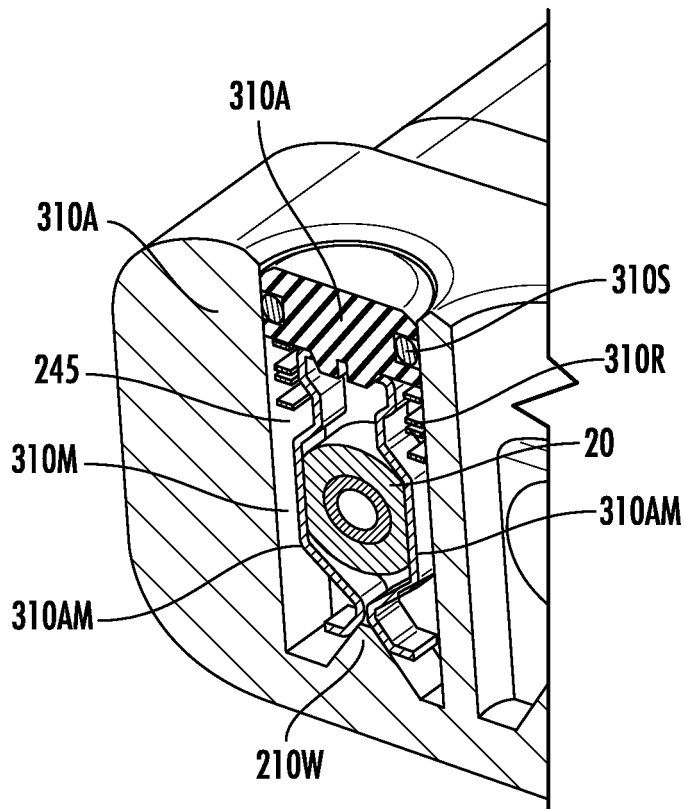

FIG. 69

59/85

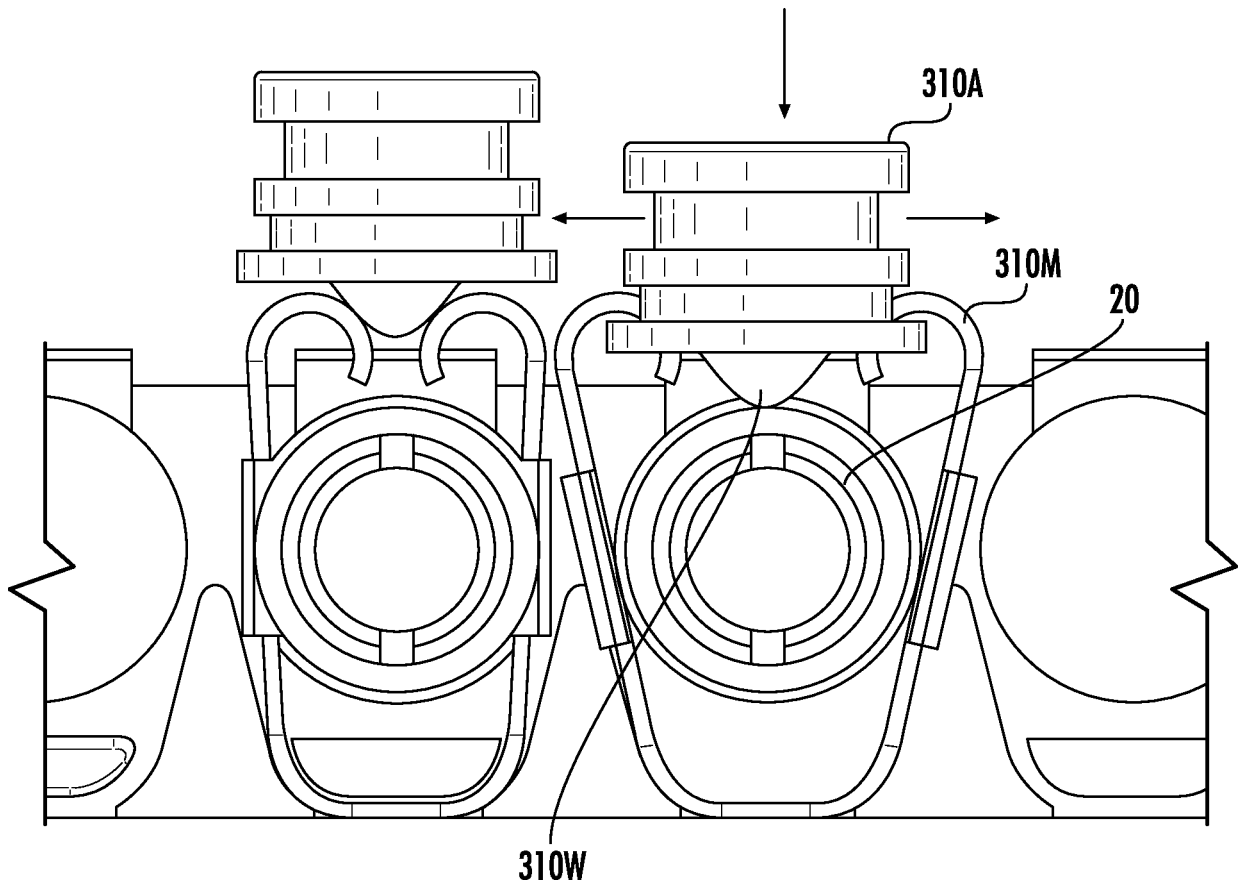

FIG. 70

60/85

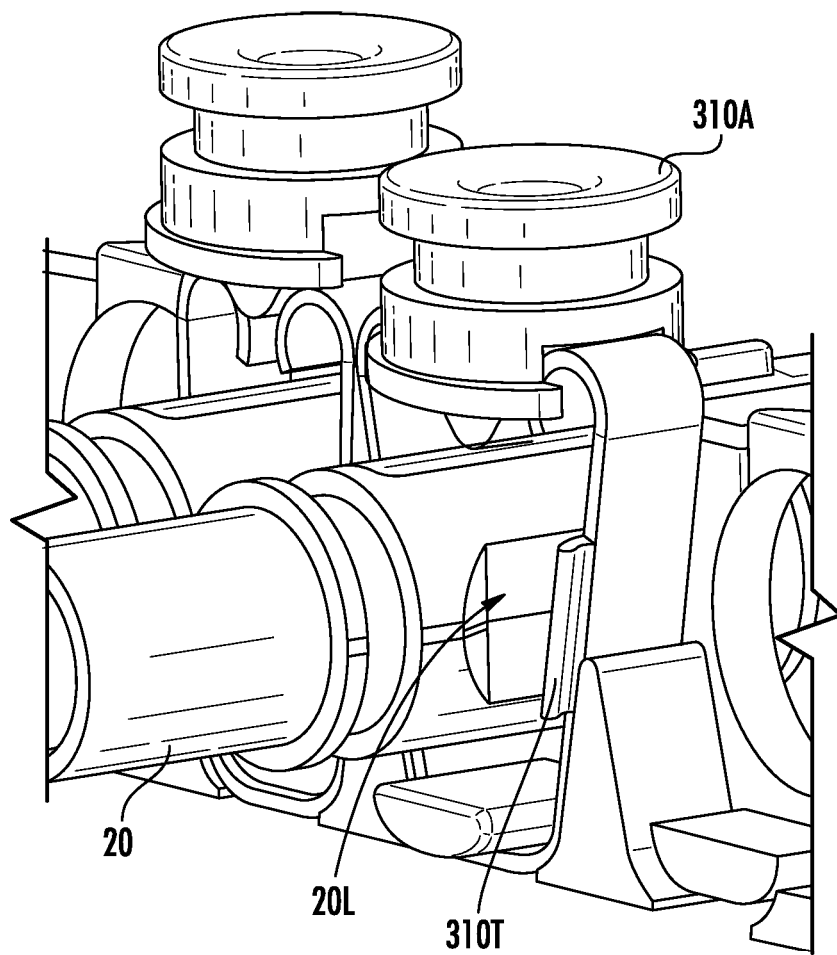

FIG. 71

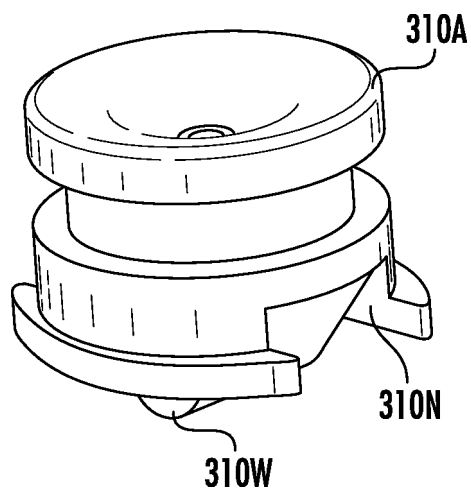

FIG. 72

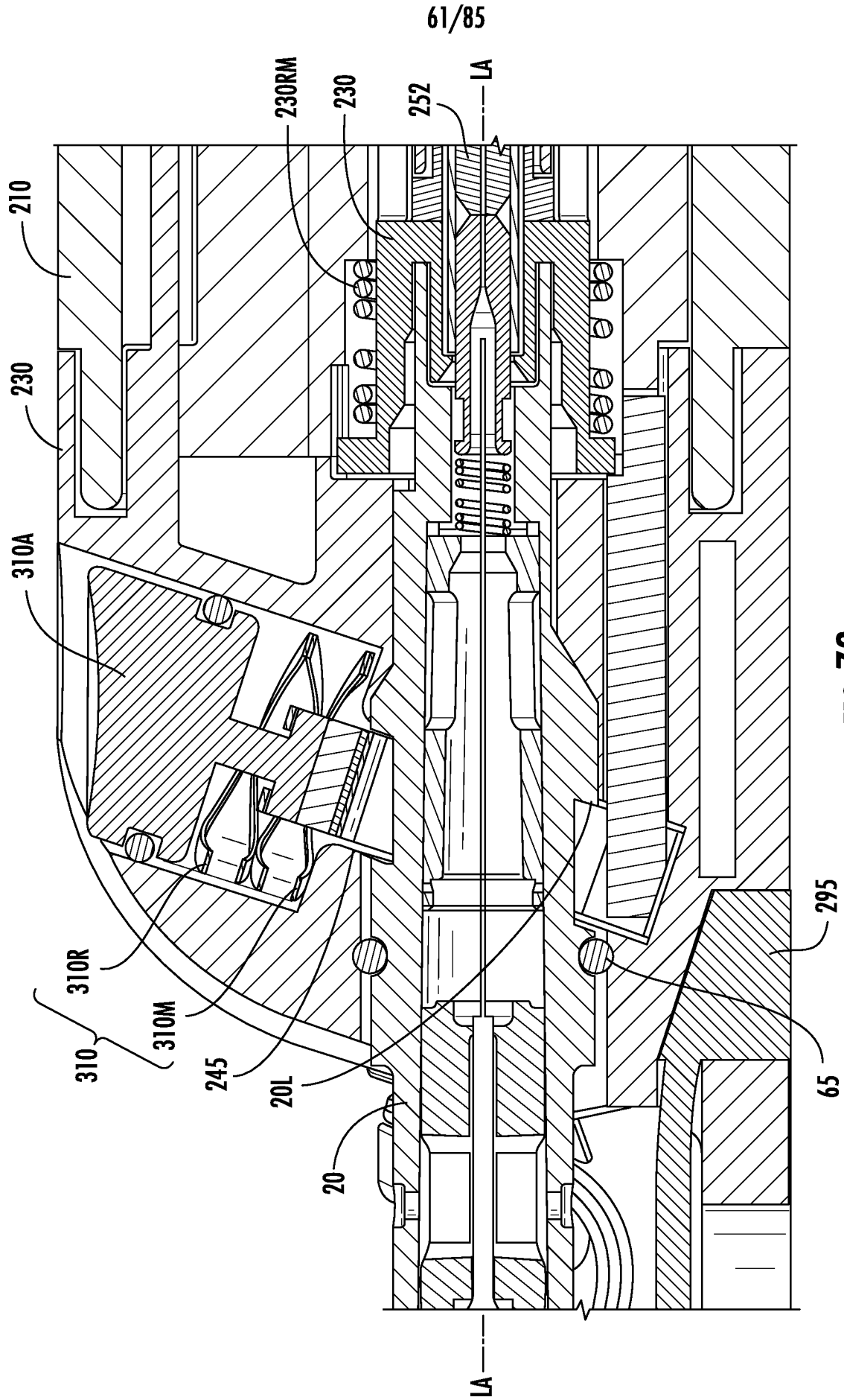

FIG. 73

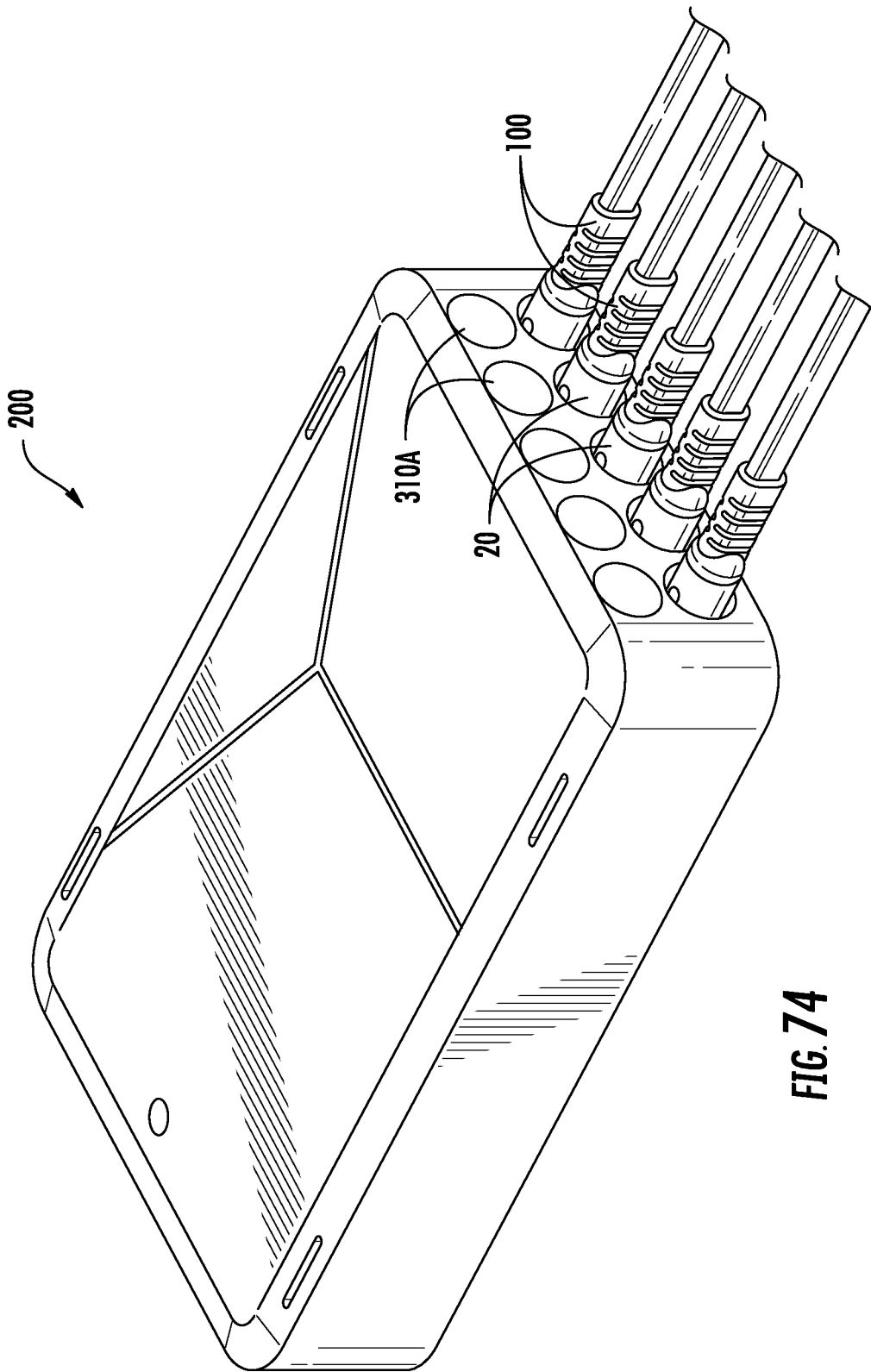

FIG. 74

63/85

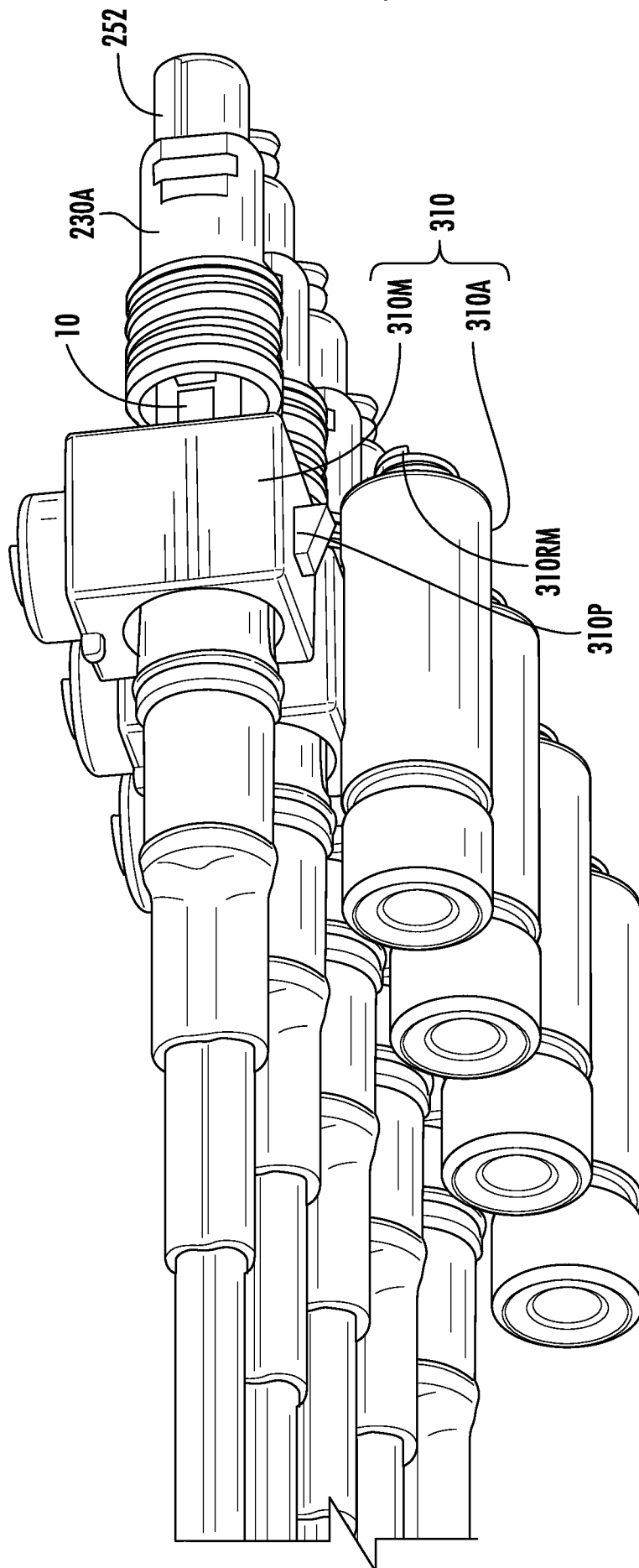

FIG. 74A

64/85

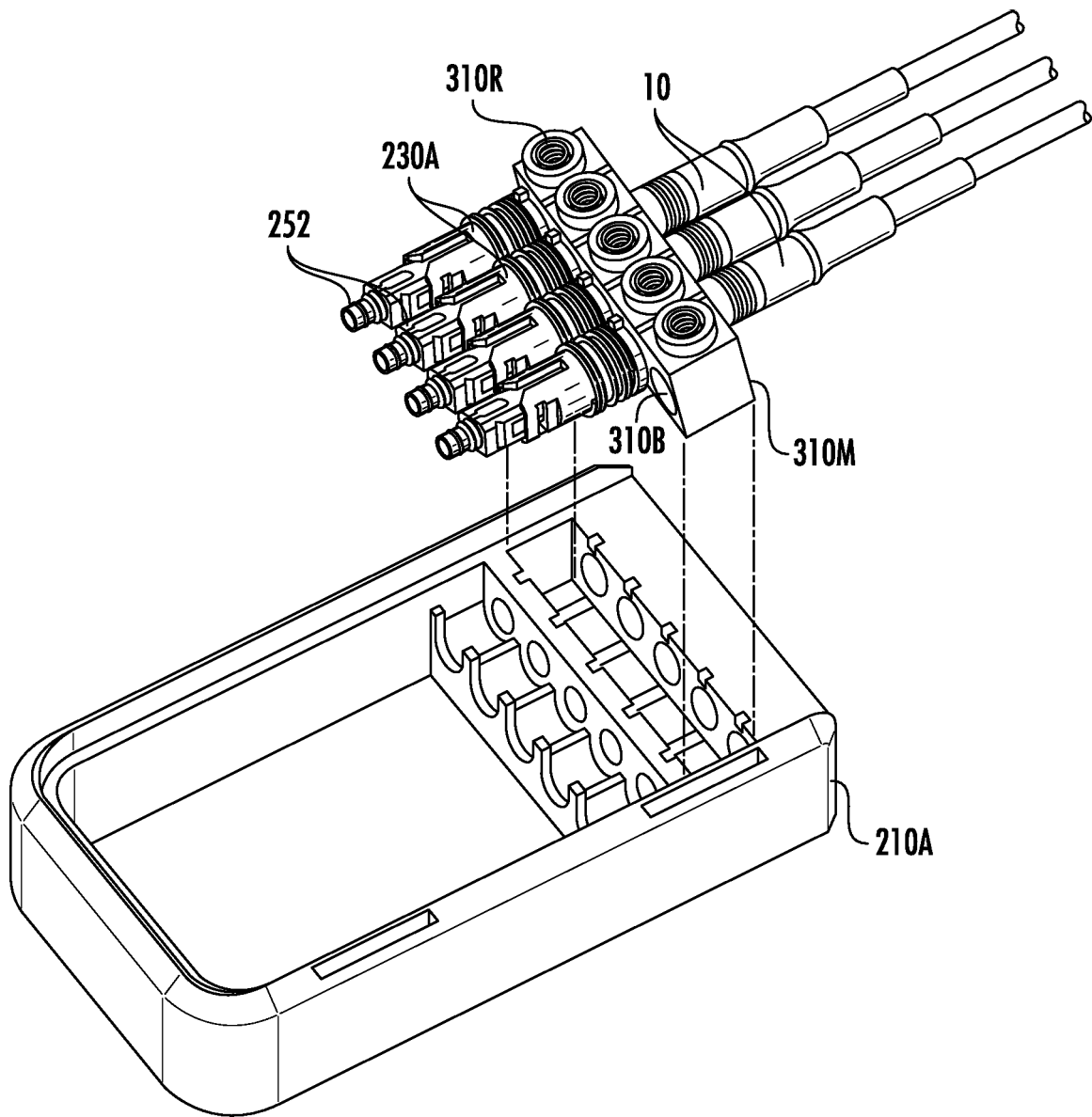
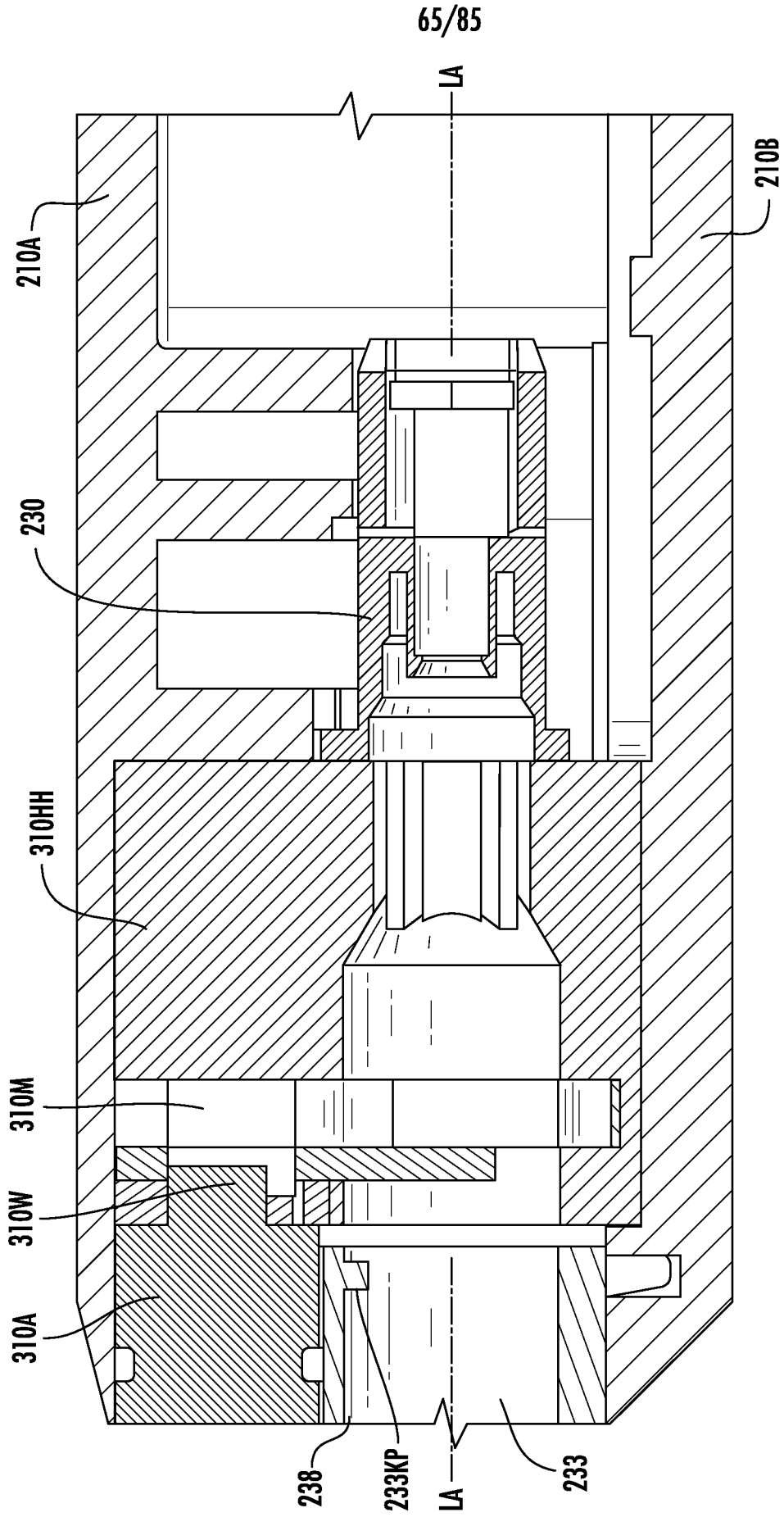

FIG. 74B



66/85

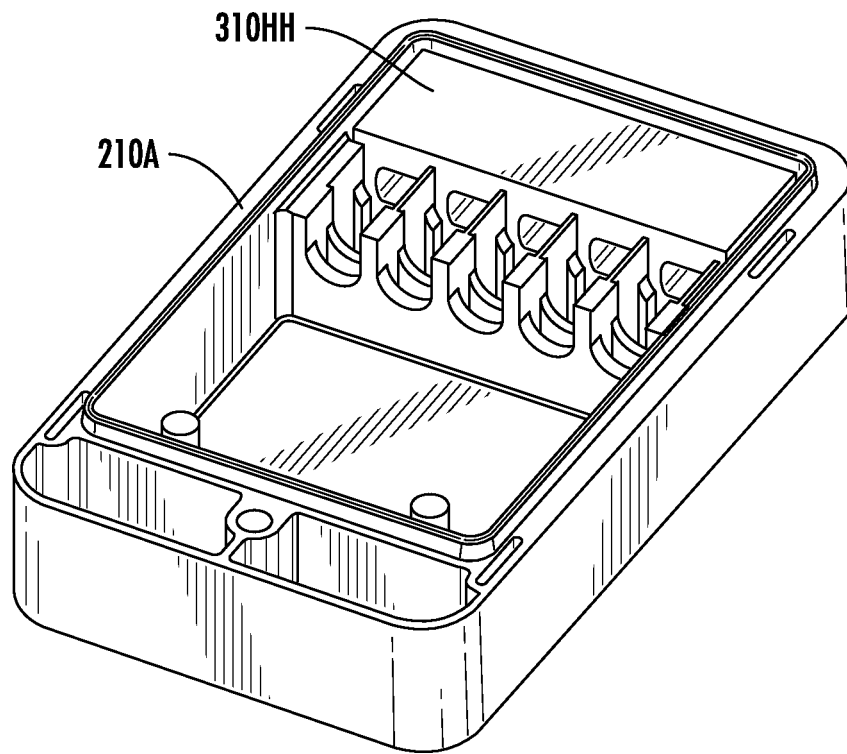

FIG. 76

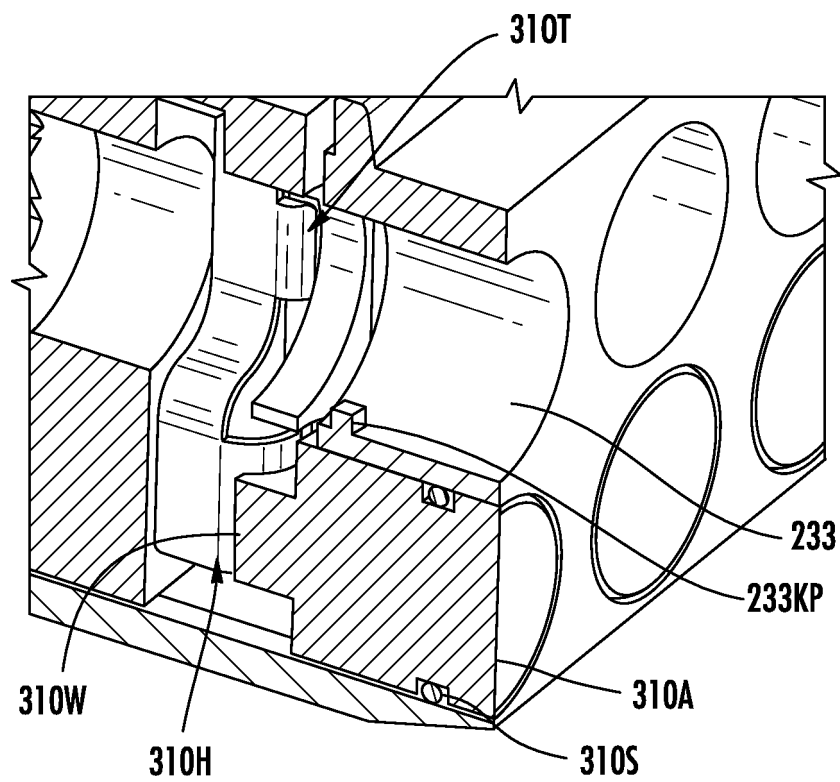

FIG. 77

67/85

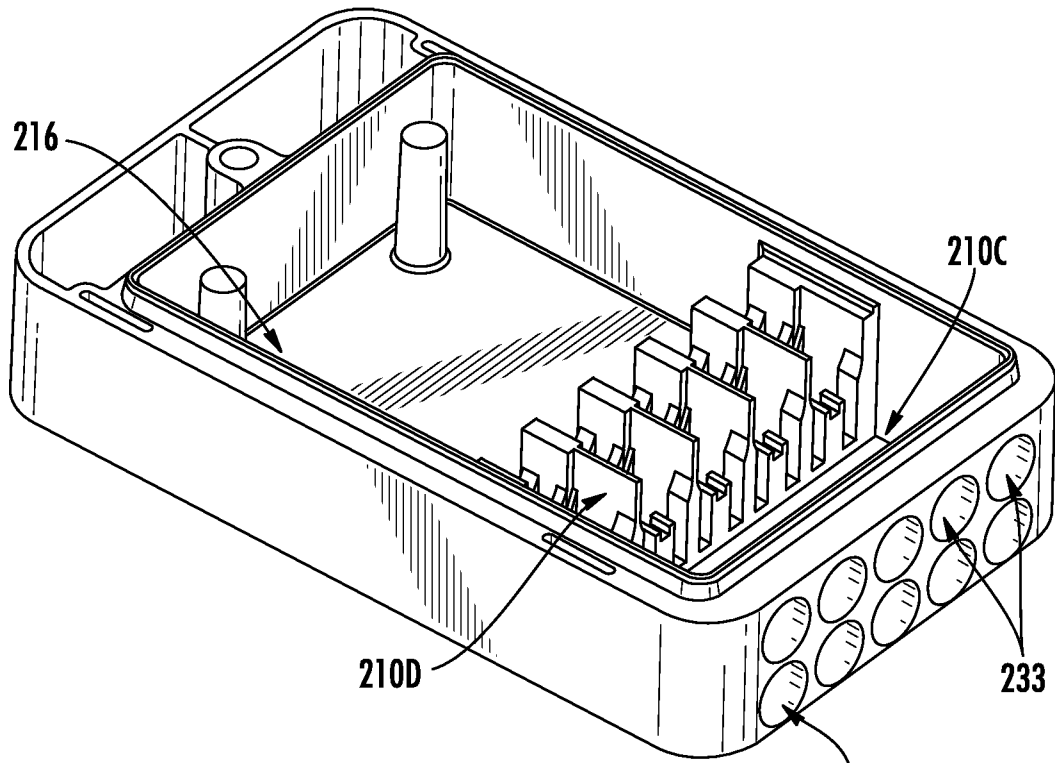

FIG. 78

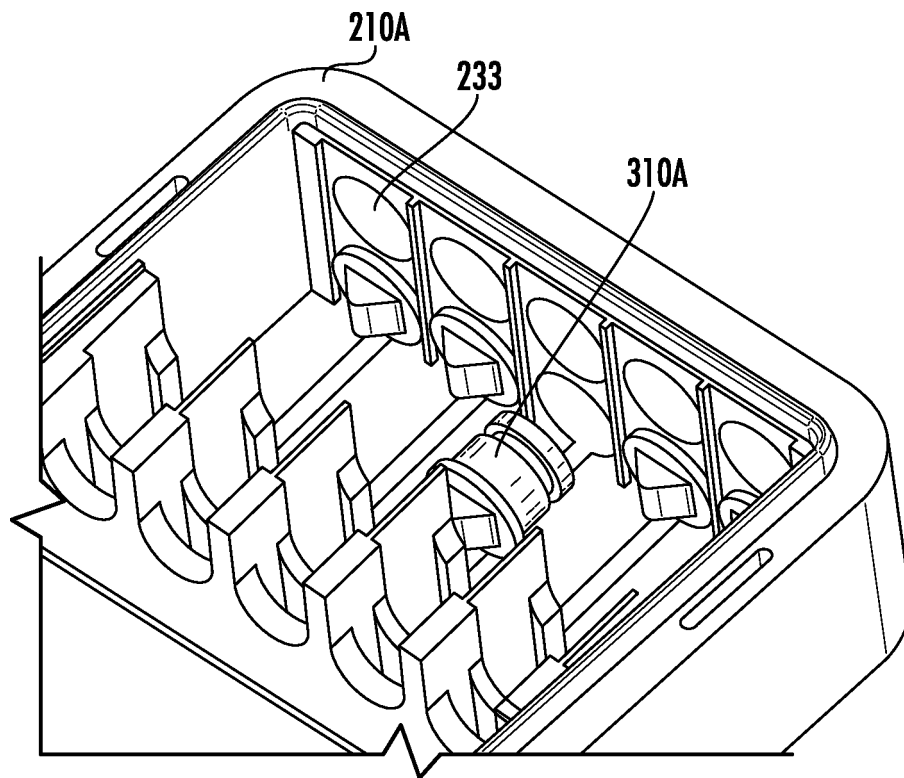

FIG. 79

68/85

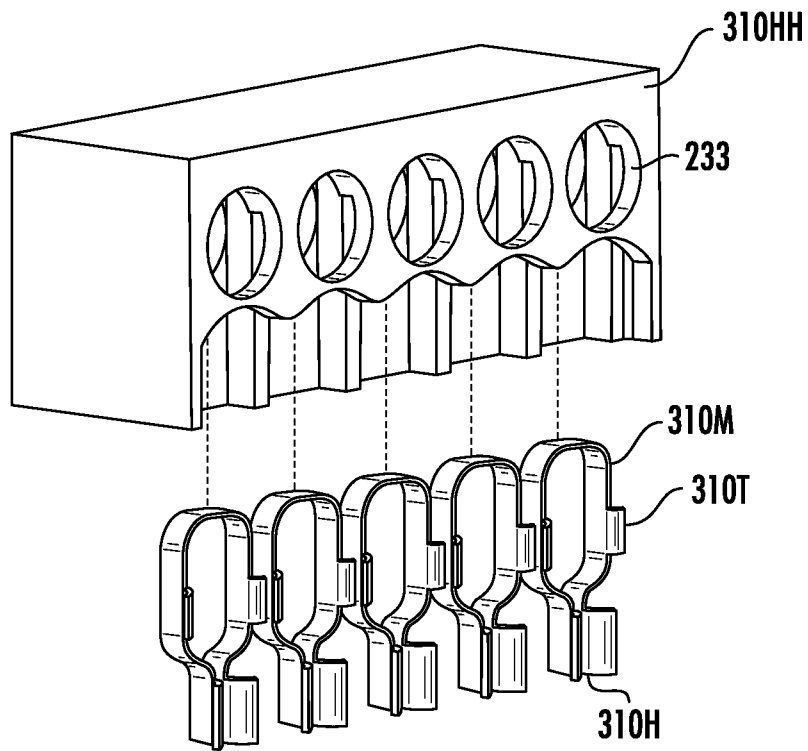

FIG. 80

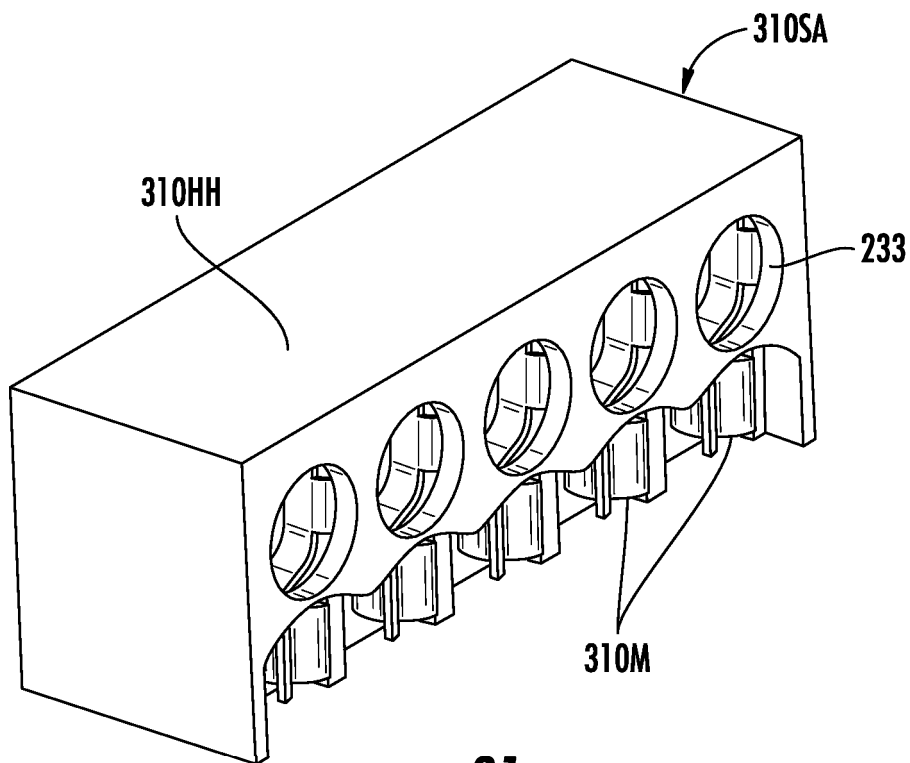

FIG. 81

69/85

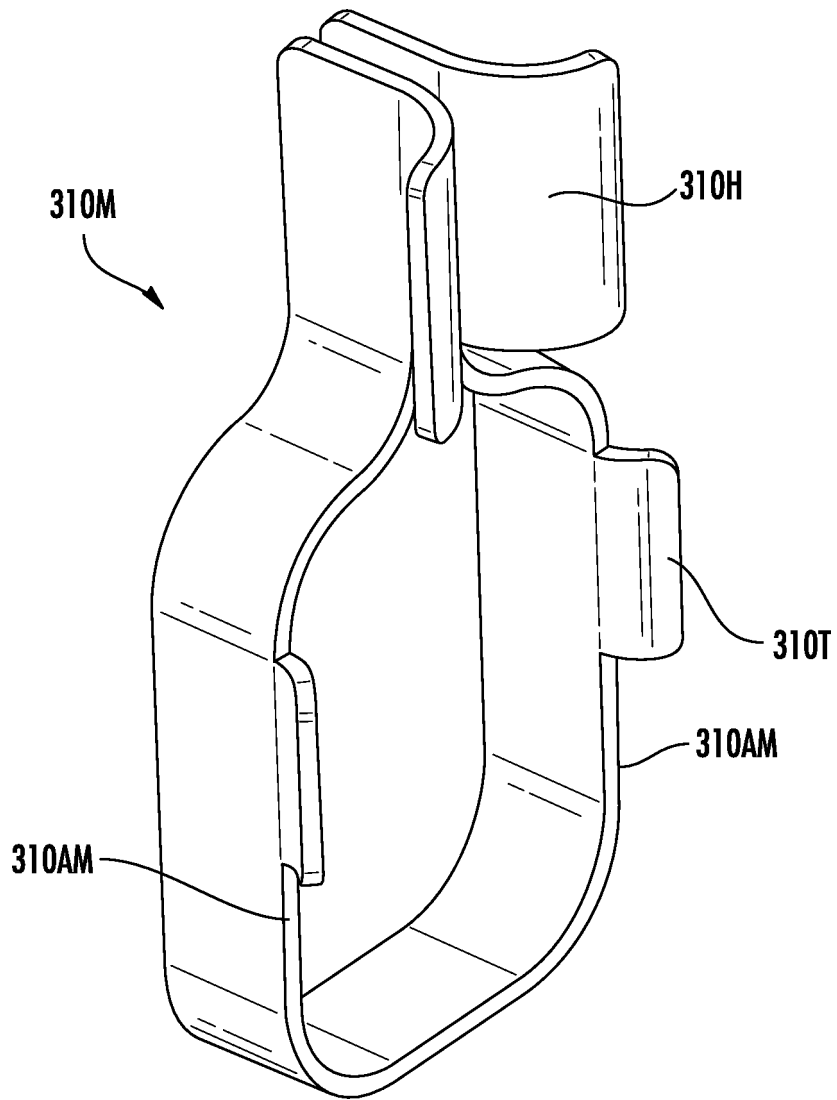

FIG. 82

70/85

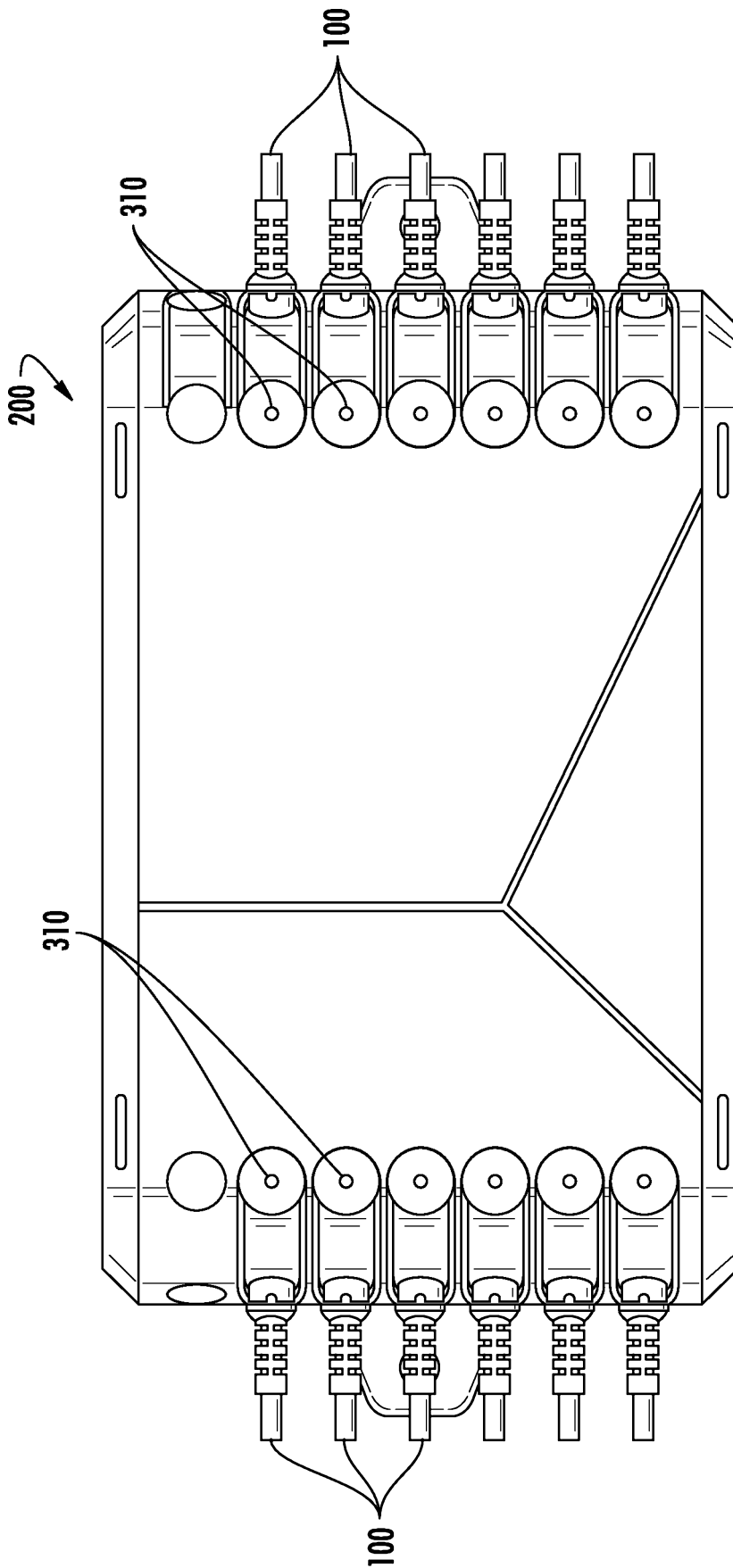

FIG. 83

71/85

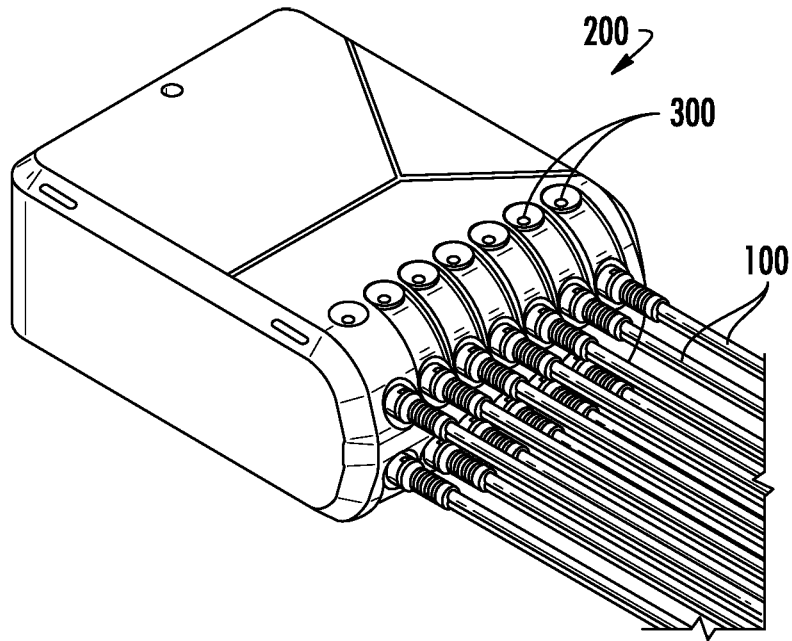

FIG. 84

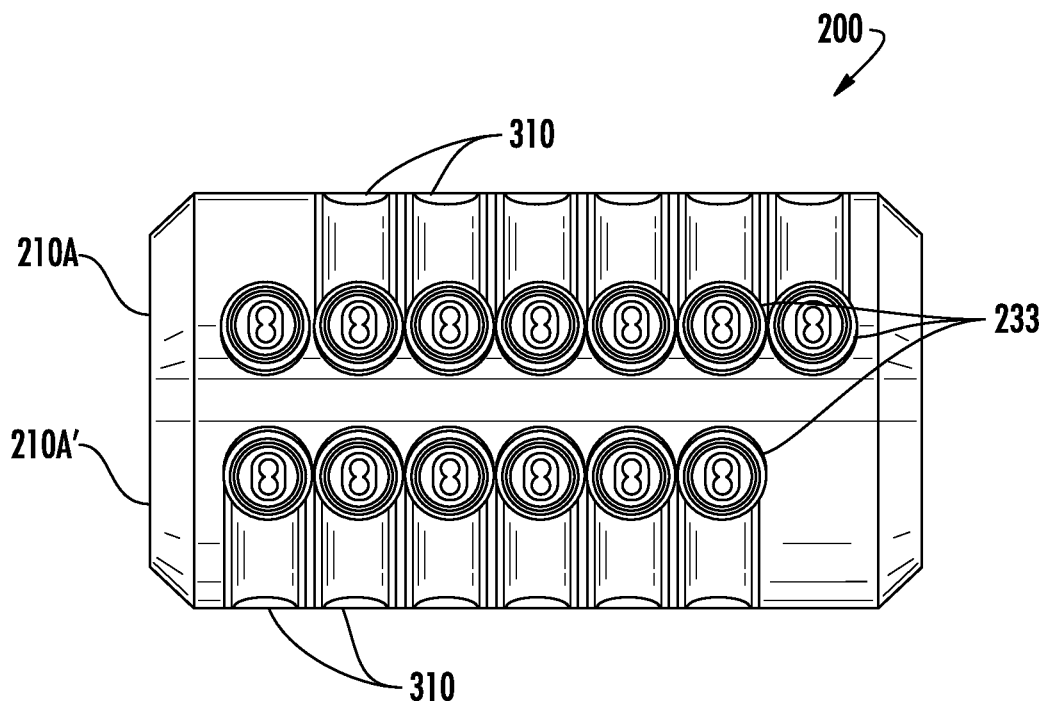

FIG. 85

73/85

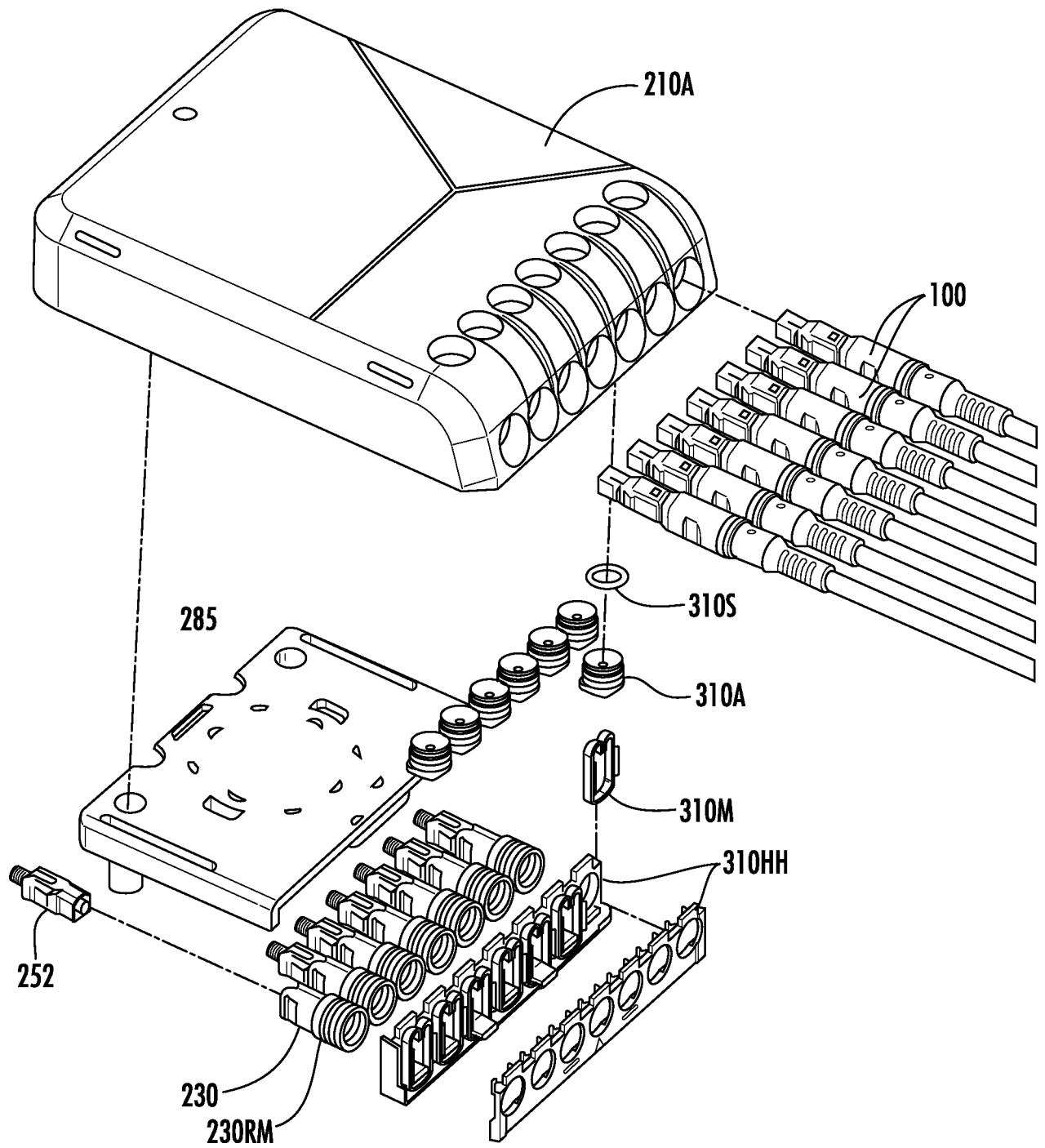

FIG. 87

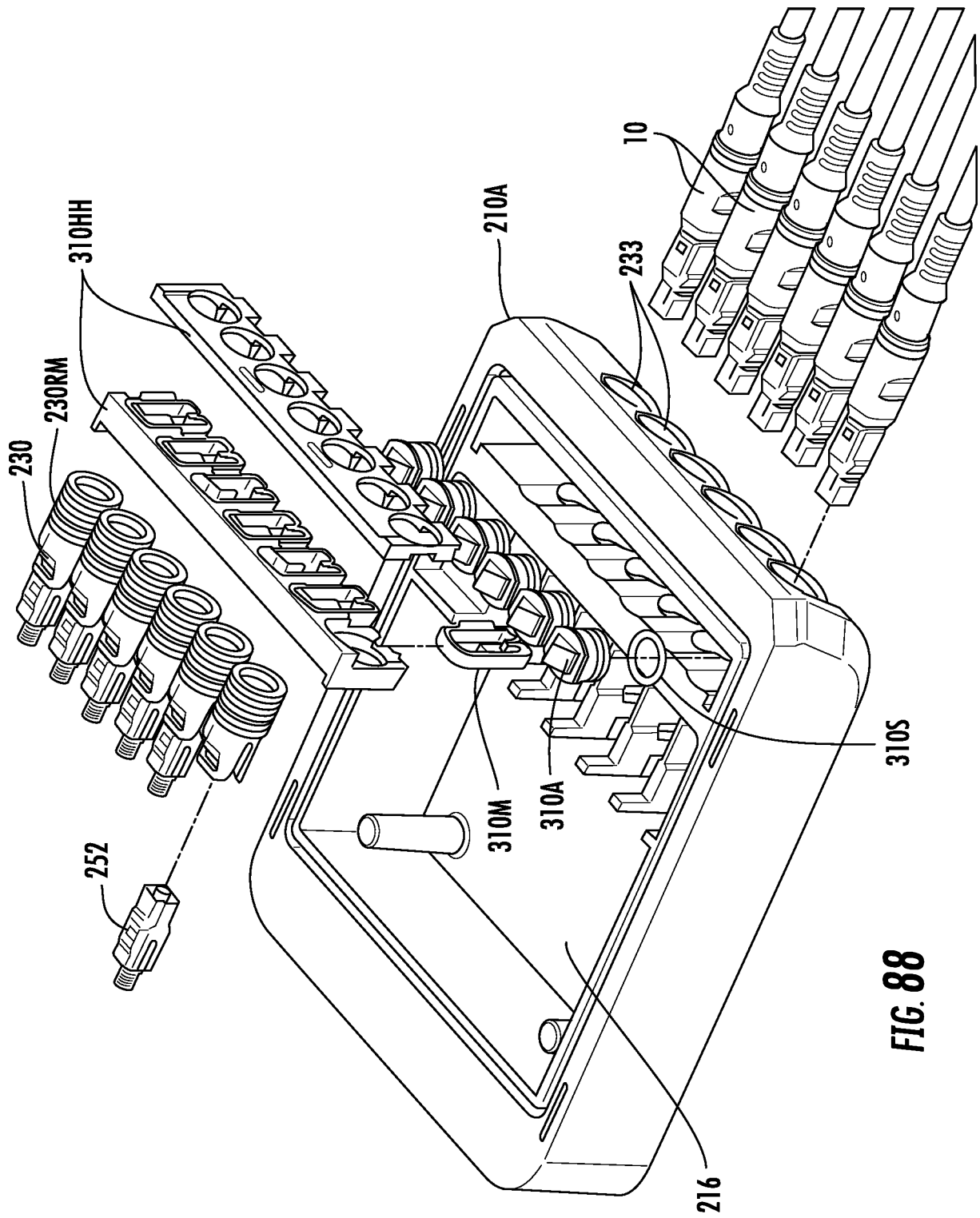

FIG. 88

75/85

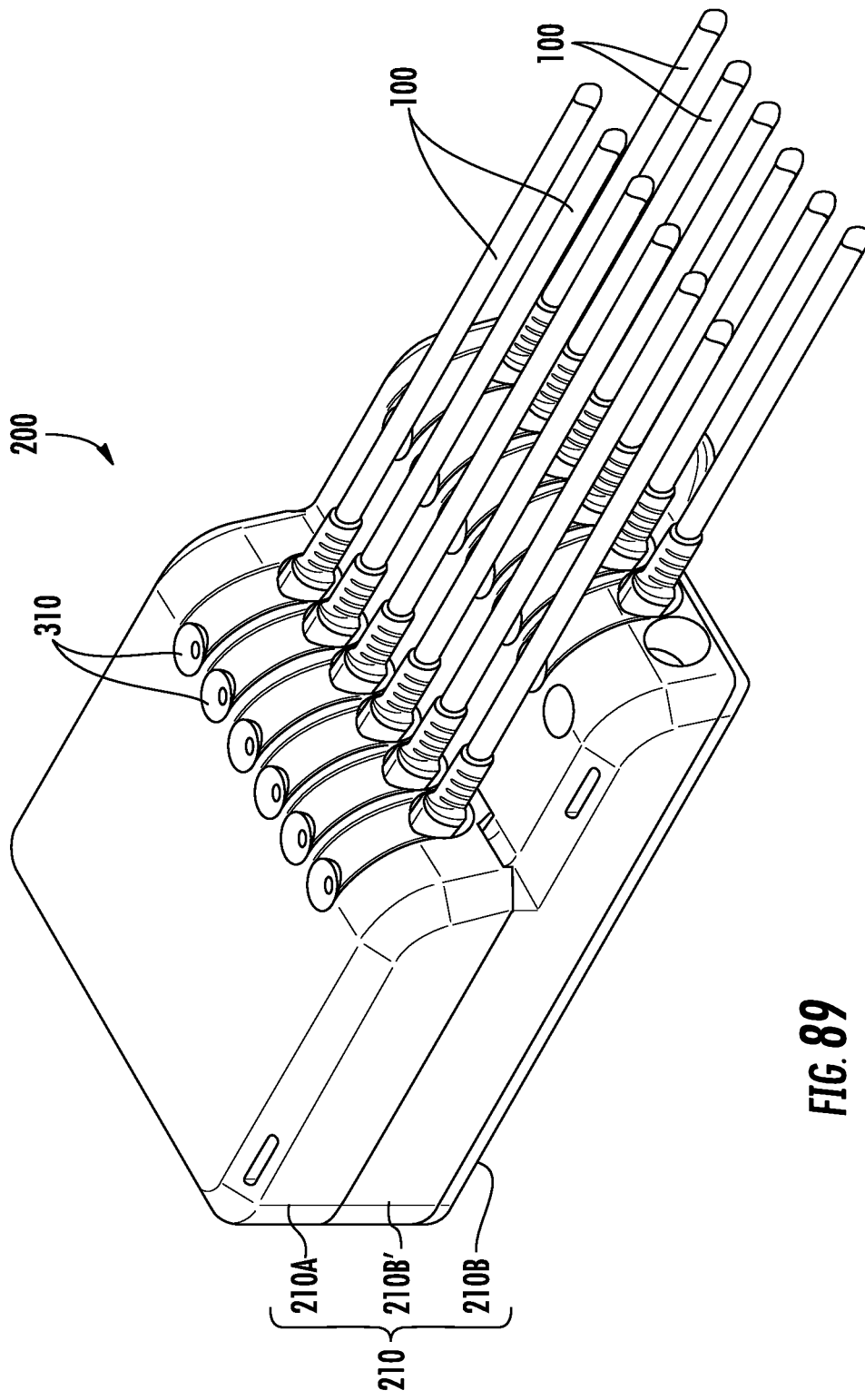

FIG. 89

76/85

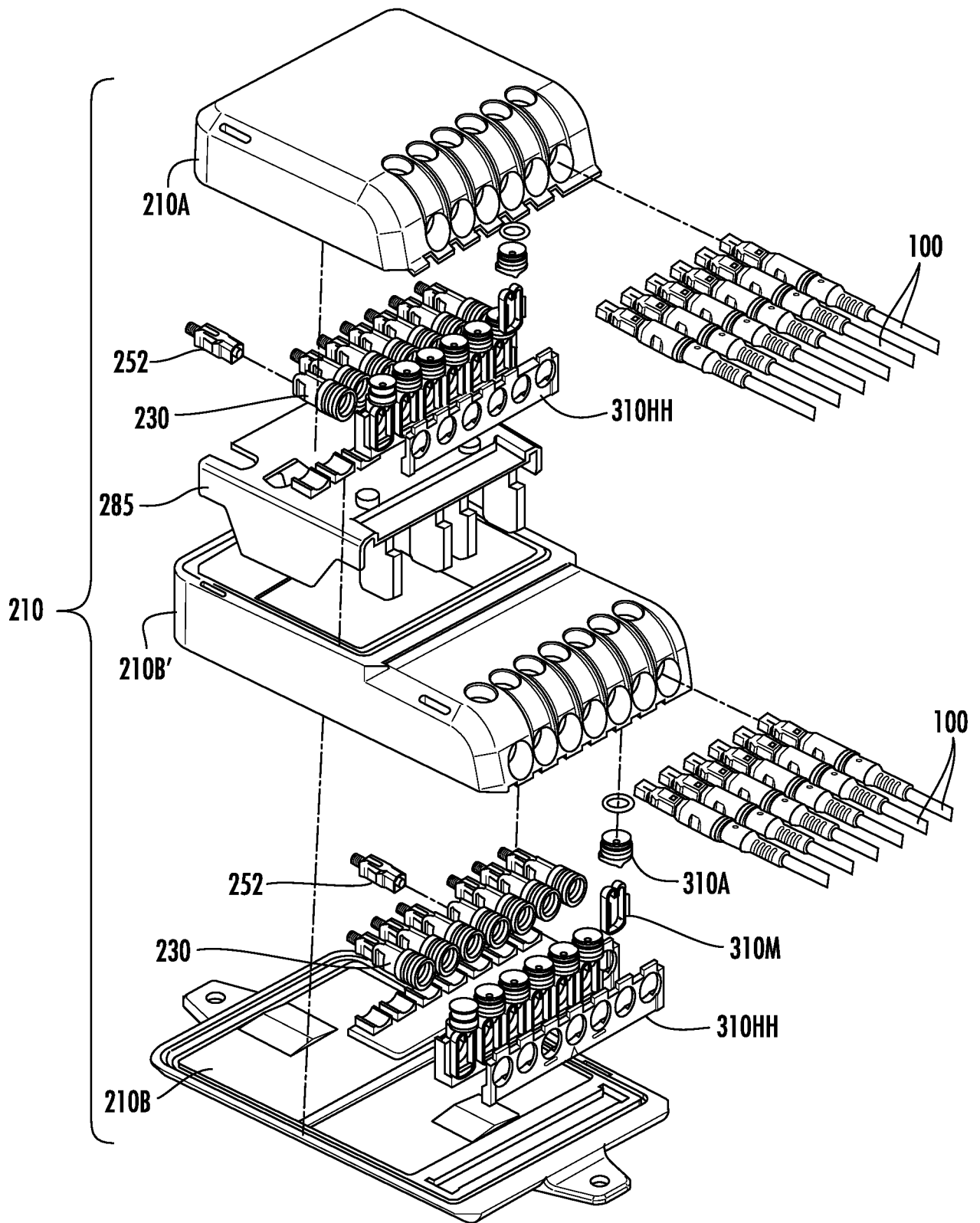

FIG. 90

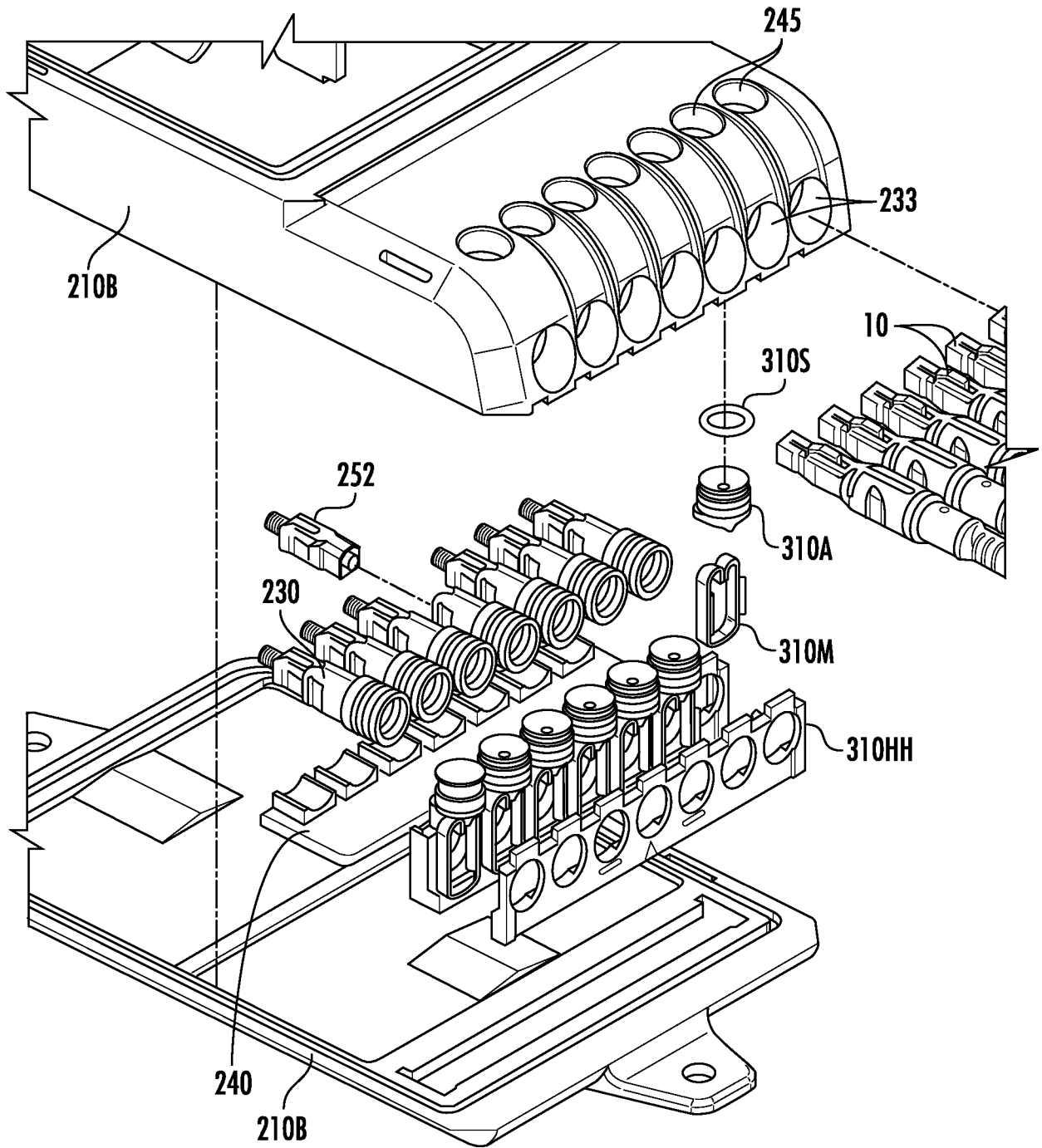

FIG. 91

78/85

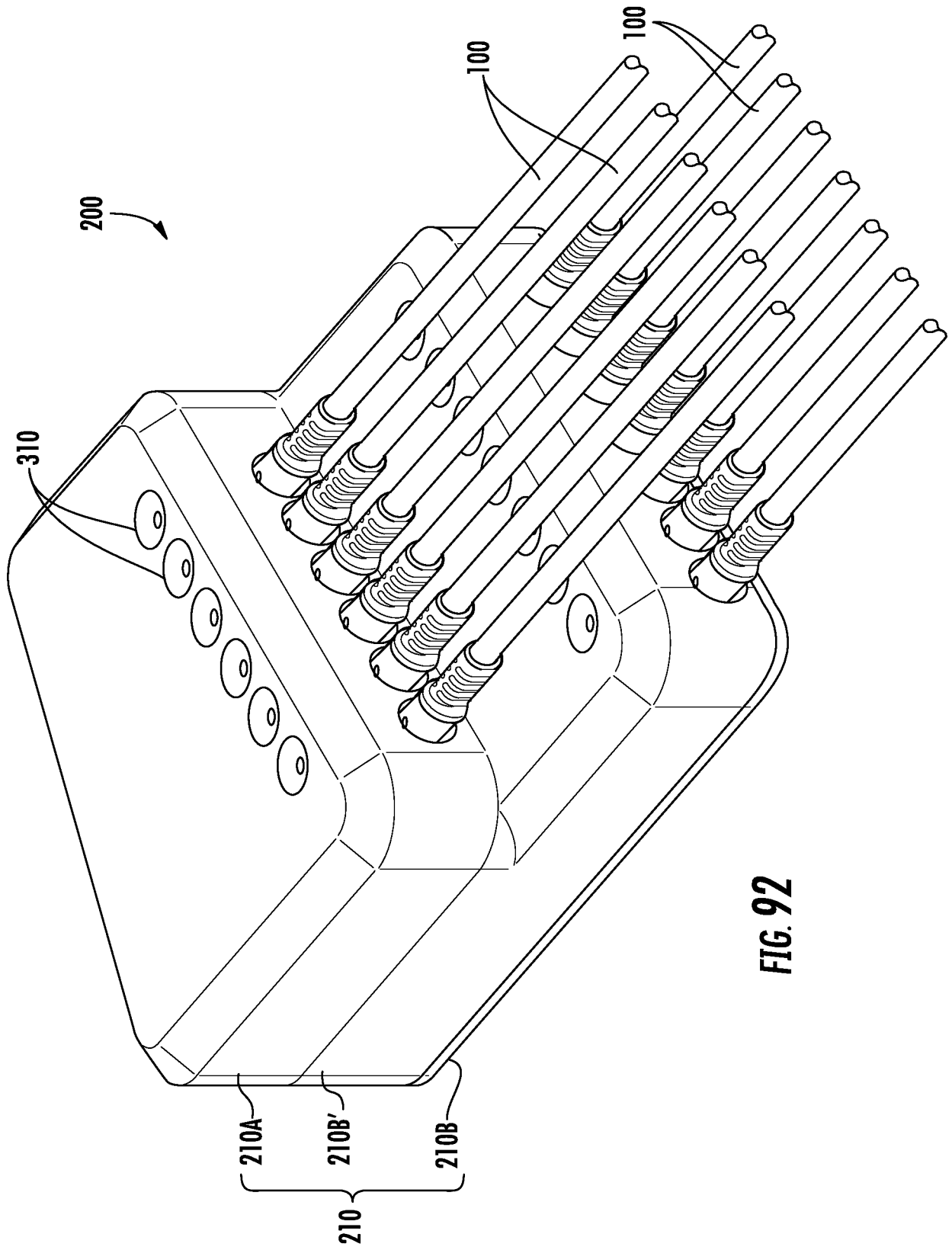
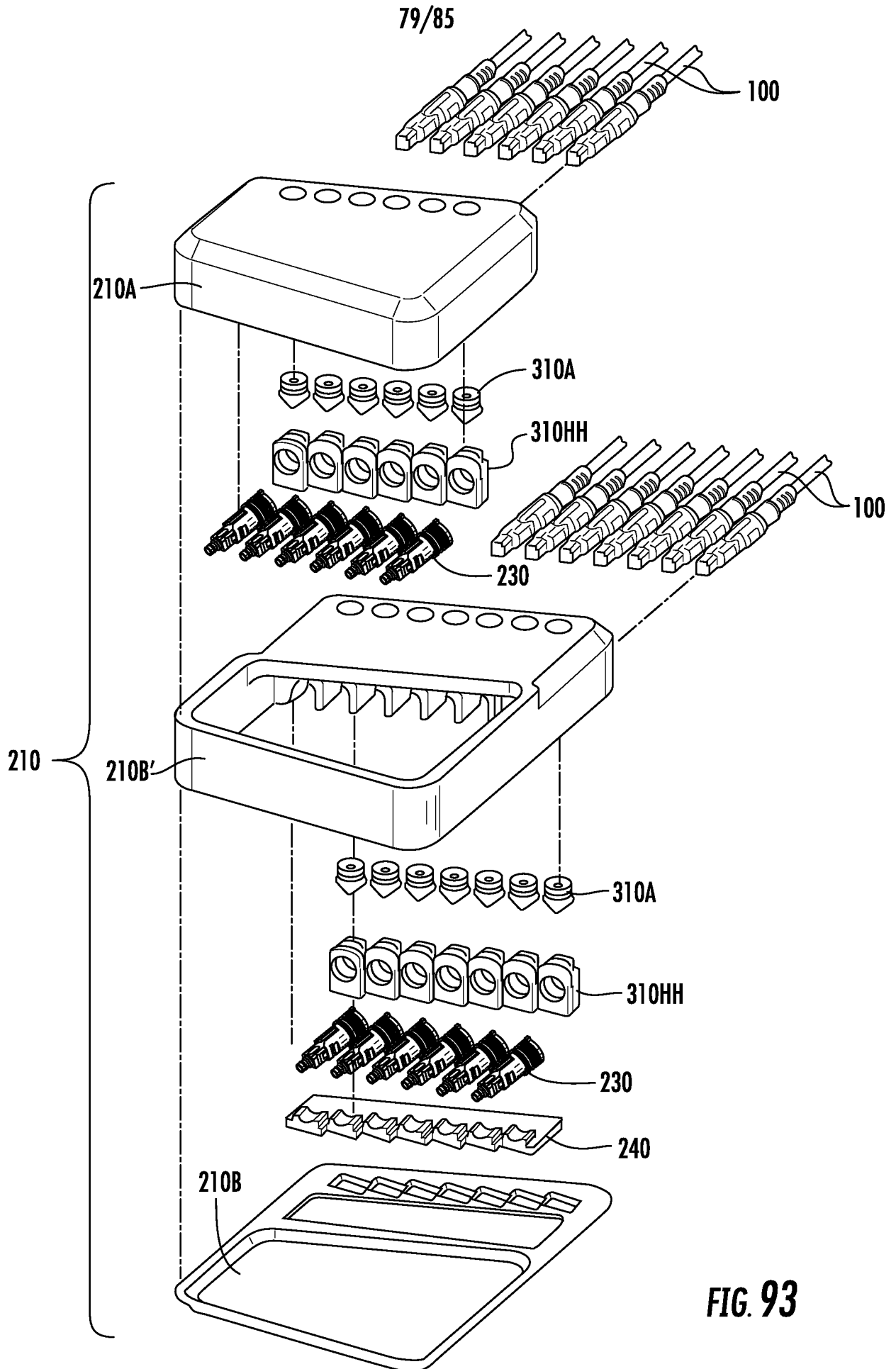

FIG. 92



80/85

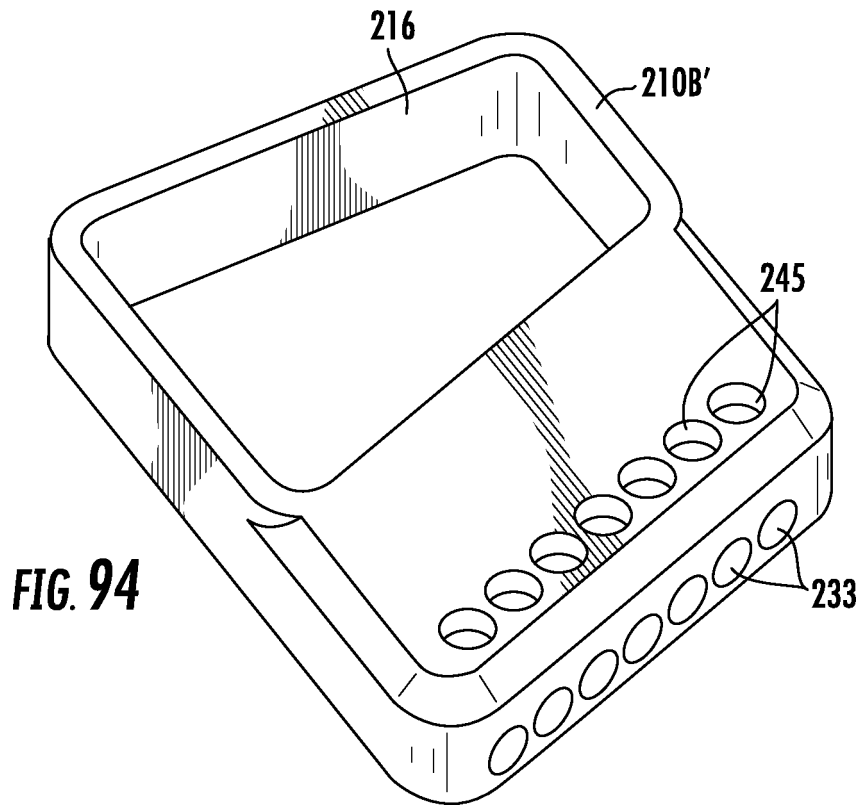

FIG. 94

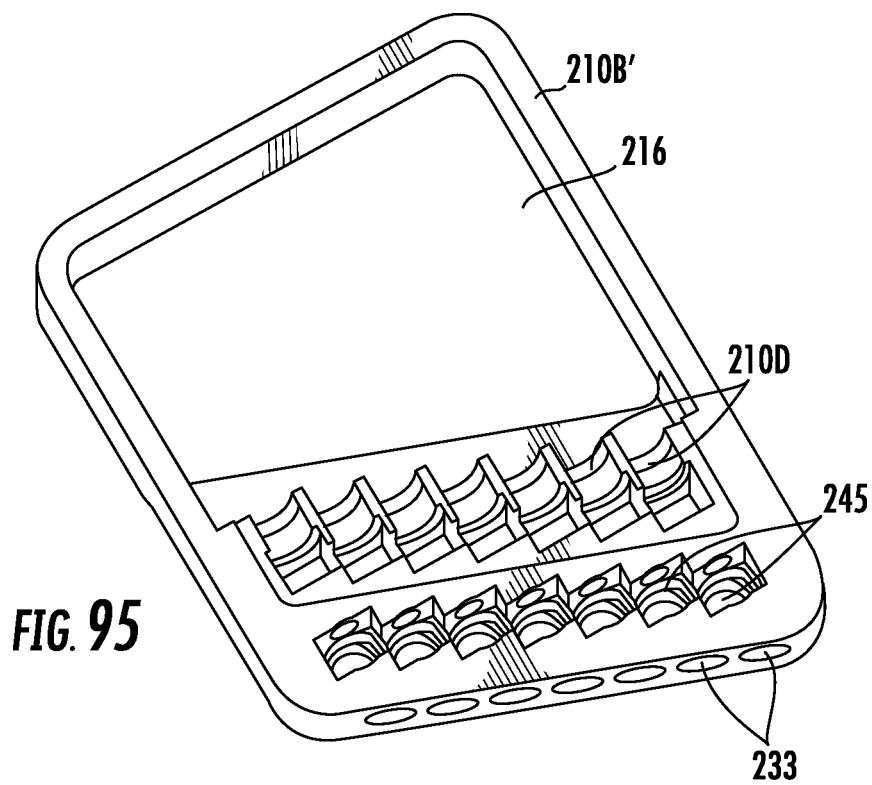

FIG. 95

81/85

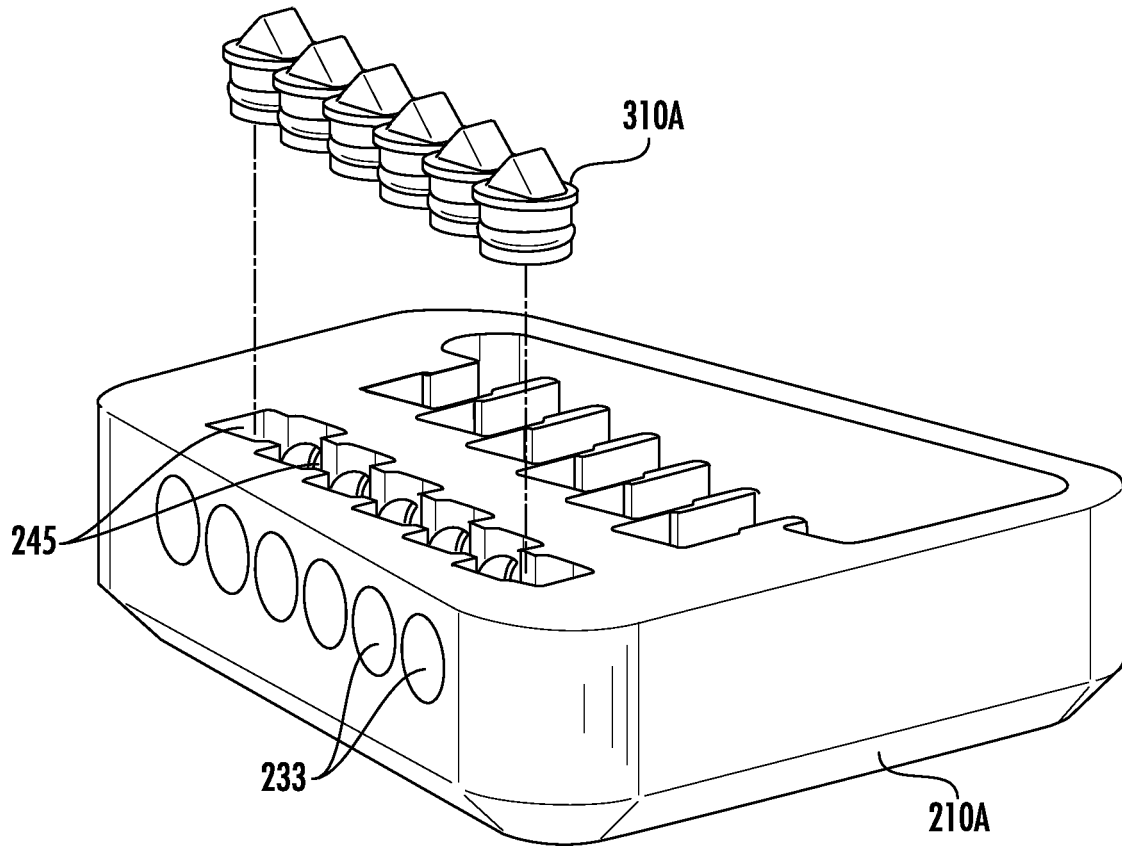

FIG. 96

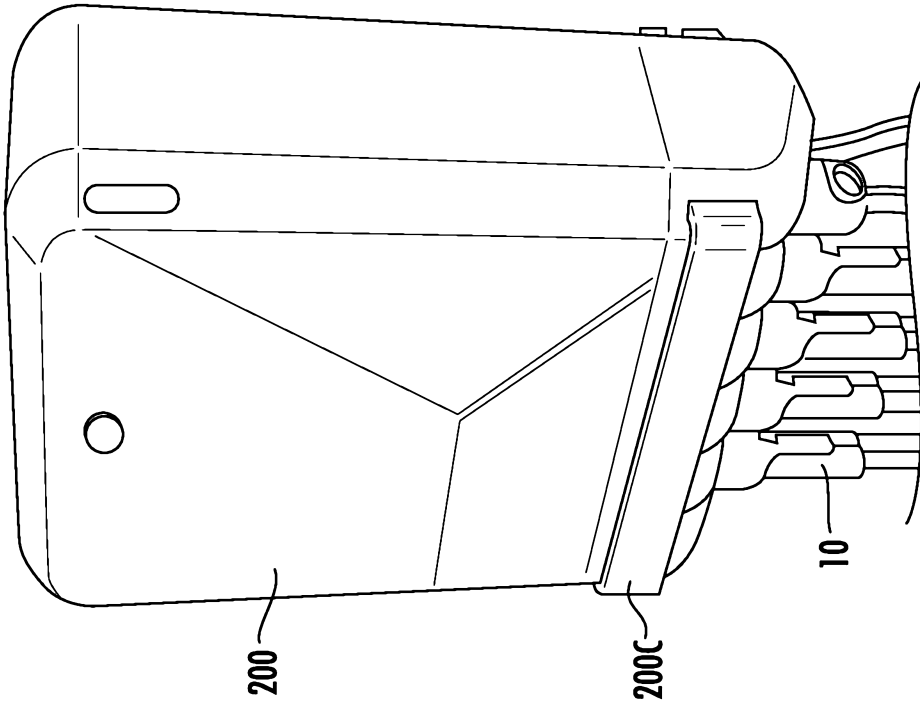

FIG. 98

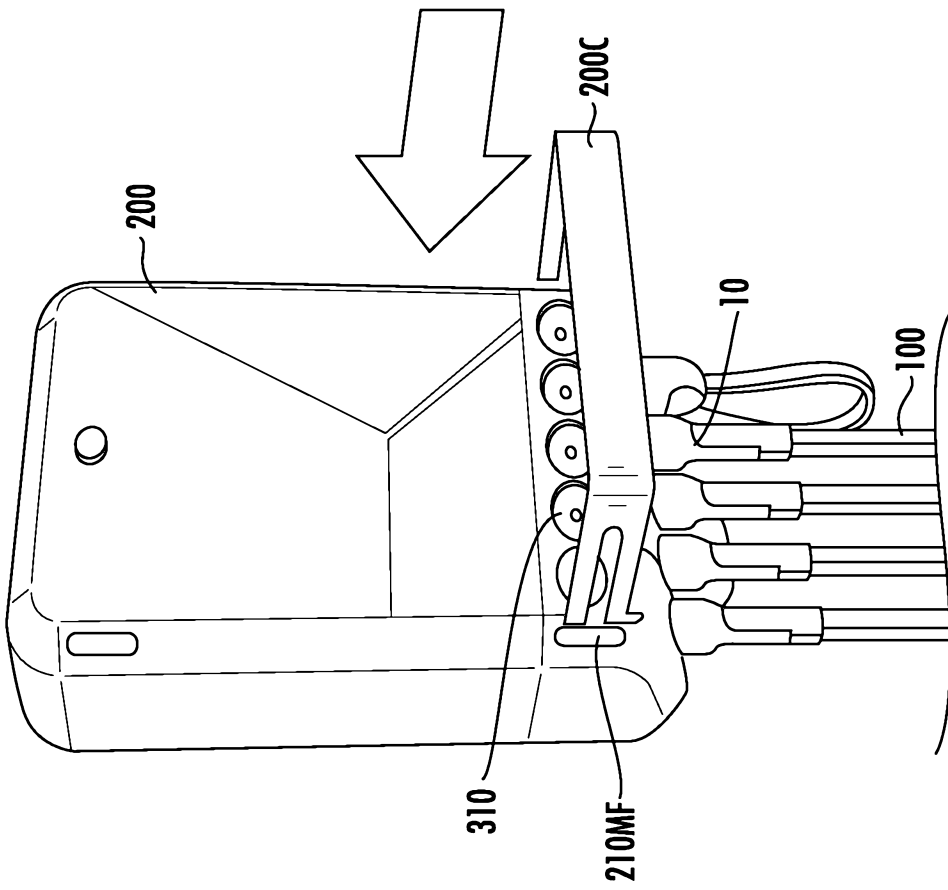
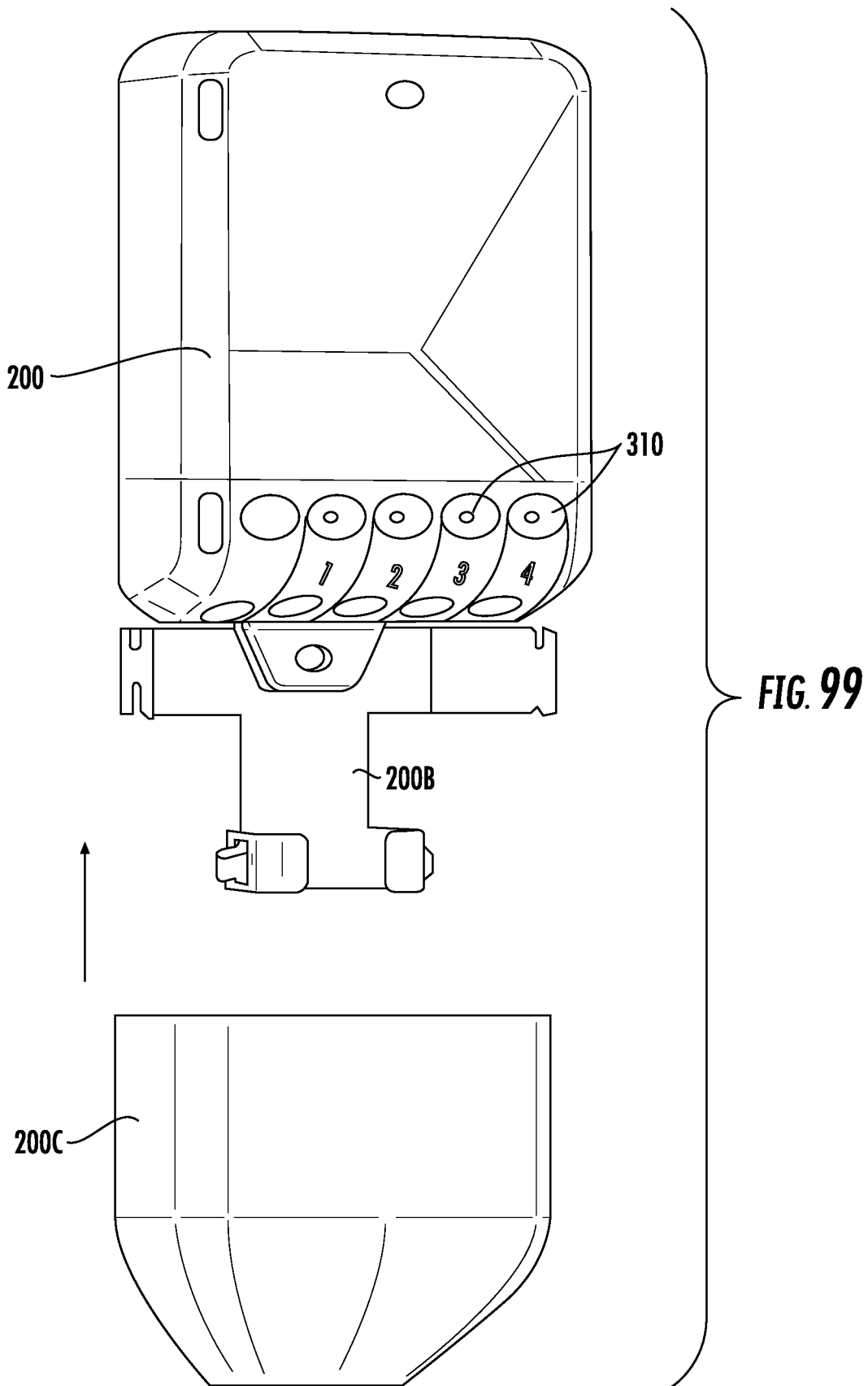

FIG. 97

83/85



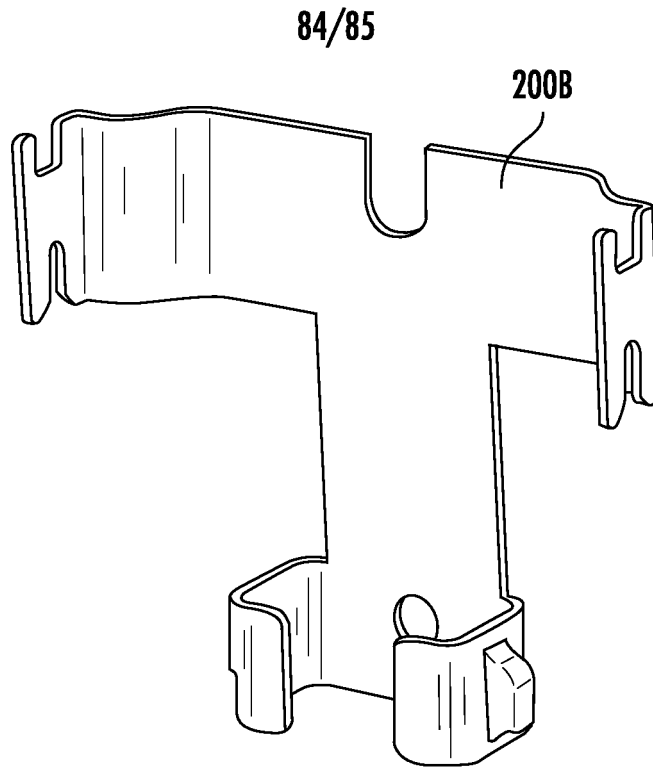

FIG. 100

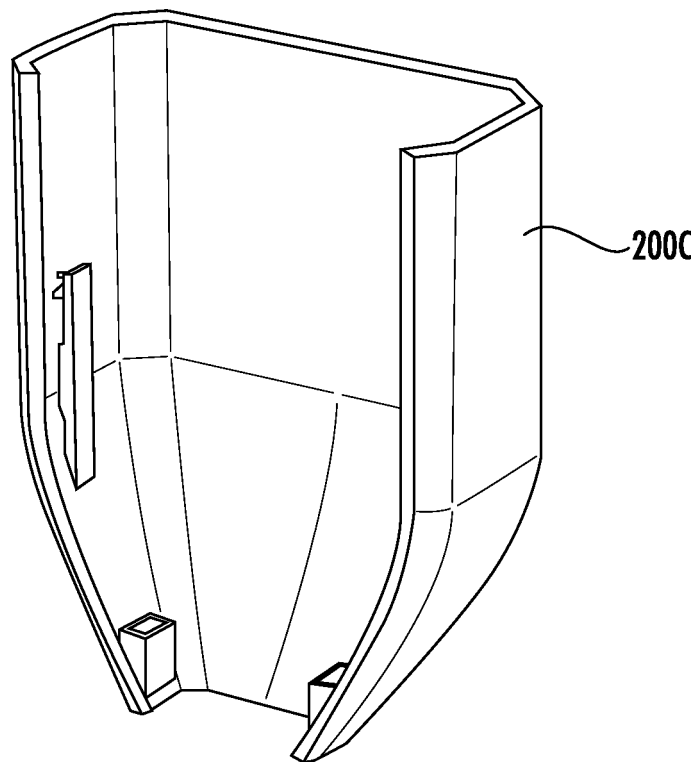

FIG. 101

85/85

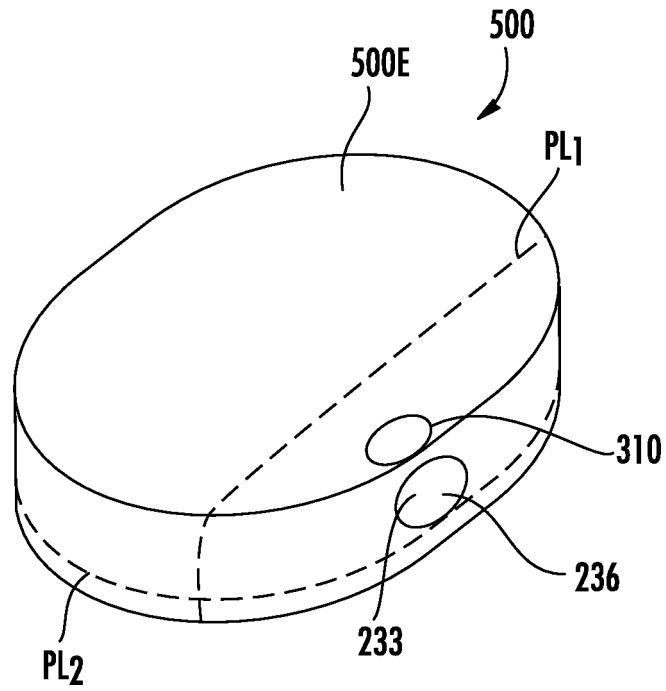

FIG. 102

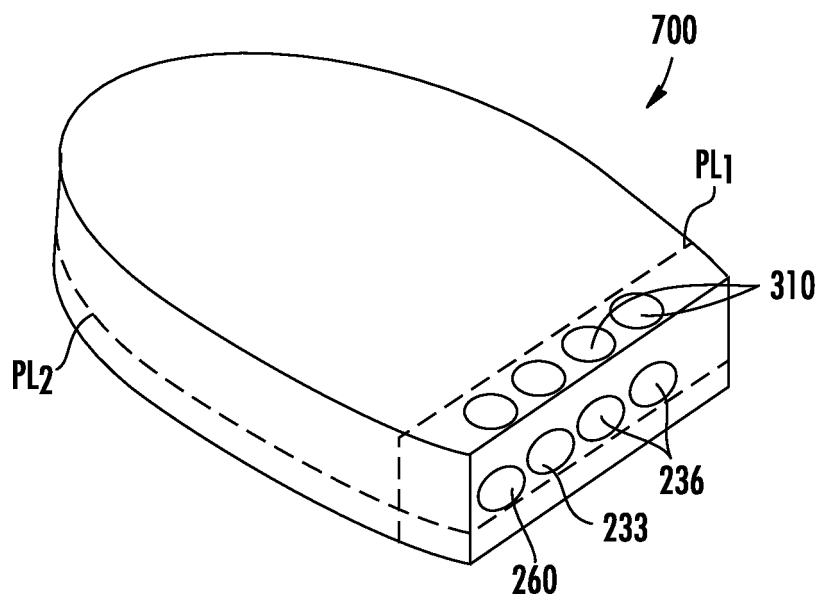

FIG. 103