

(12) **UK Patent Application** (19) **GB** (11) **2479221** (13) **A**

(43) Date of A Publication

**05.10.2011**

(21) Application No: **1017366.4**  
(22) Date of Filing: **14.10.2010**  
(30) Priority Data:  
(31) **1005482** (32) **31.03.2010** (33) **GB**  
(31) **1010269** (32) **18.06.2010** (33) **GB**  
(31) **1015814** (32) **21.09.2010** (33) **GB**

(51) INT CL:  
**E02F 3/36** (2006.01)

(56) Documents Cited:  
**GB 2467380 A** **GB 2463298 A**  
**EP 2119834 A2** **EP 2076631 A2**  
**US 20090007465 A1**

(58) Field of Search:  
INT CL **E02F**  
Other: **Online : WPI, EPODOC**

(71) Applicant(s):  
**Ian Hill**  
**30 Shinn Road, Newry, County Down, BT34 1PB,**  
**United Kingdom**

(72) Inventor(s):  
**Ian Hill**

(74) Agent and/or Address for Service:  
**FRKelly**  
**4 Mount Charles, BELFAST, Northern Ireland,**  
**BT7 1NZ, United Kingdom**

(54) Title of the Invention: **Coupler**  
Abstract Title: **Coupler with an actuated latch and a blocking member operated indirectly by the actuators operation**

(57) A coupler 10 for an excavator including first 20 and second 22 recesses for receiving an attachment, a latch 2 movable to close the second recess 22 and a blocking member 6 which closes the first recess 20. The latch 2 is operated by an actuator 1, the actuator also acts indirectly upon the blocking member 6 moving the blocking member into and out of its locking position as the latch is operated. Preferably the actuator interacts with the blocking member via a resilient member 5 which can flex should the blocking member be obstructed to avoid excessive actuator loading. The actuator 1 and latch 2 are mounted so the actuator pivots as the latch is closed, the resilient member 5 is attached to the actuator and the blocking member and is deformed by the actuator pivoting, The resilient member 5 urges the blocking member 6 closed as it springs back.

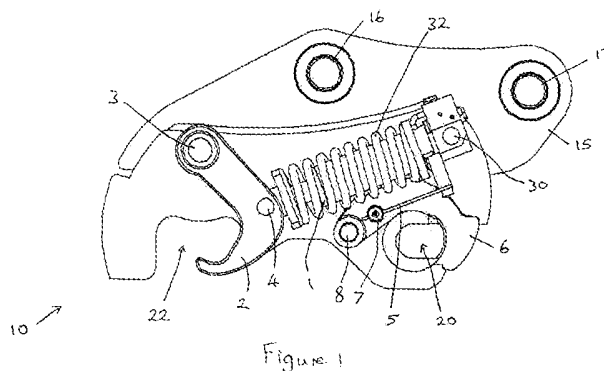

**GB 2479221 A**

1/3

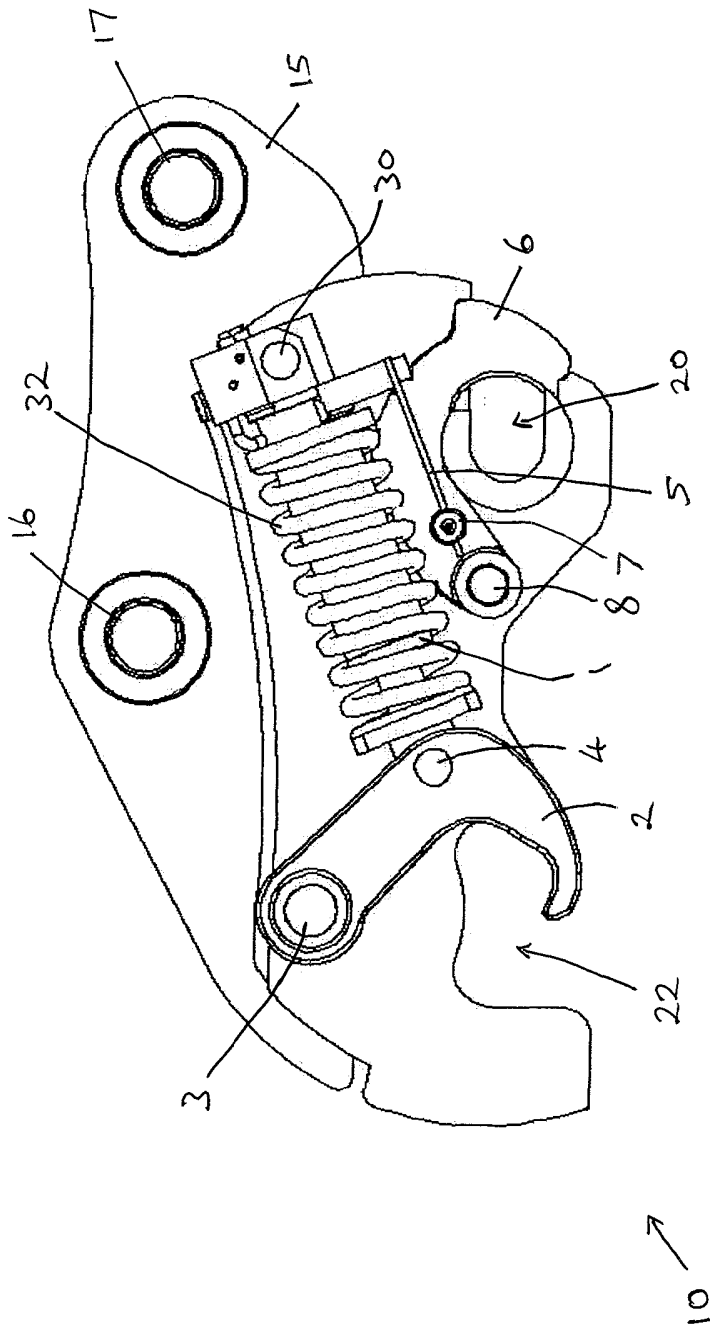

Figure 1



3/3

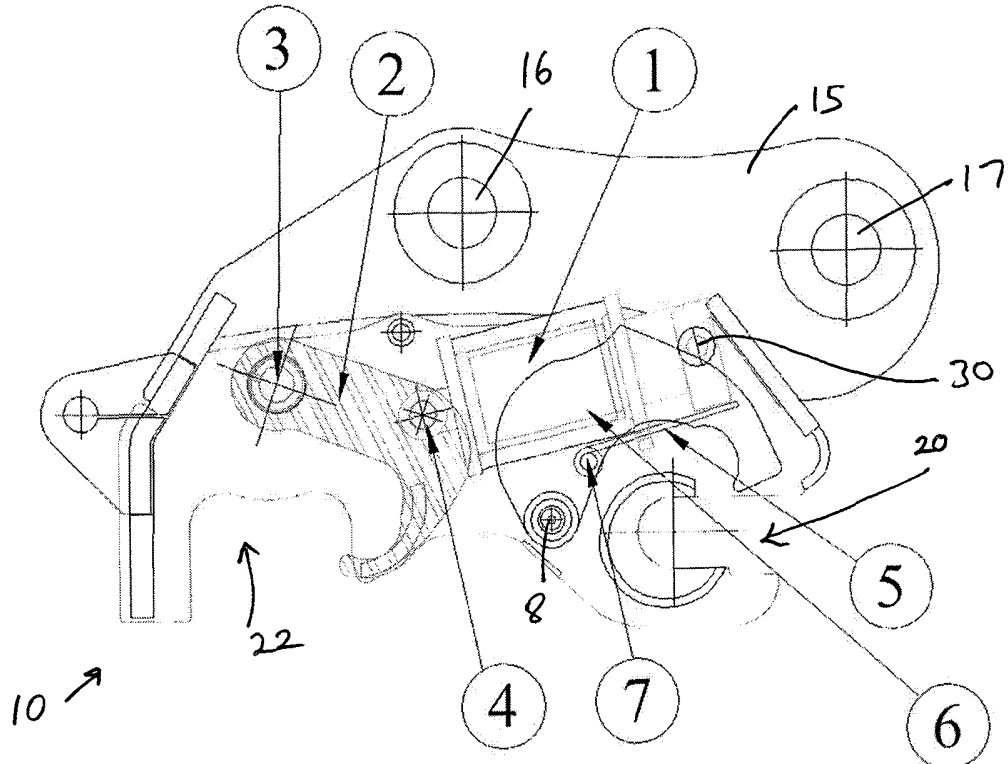

Figure 4

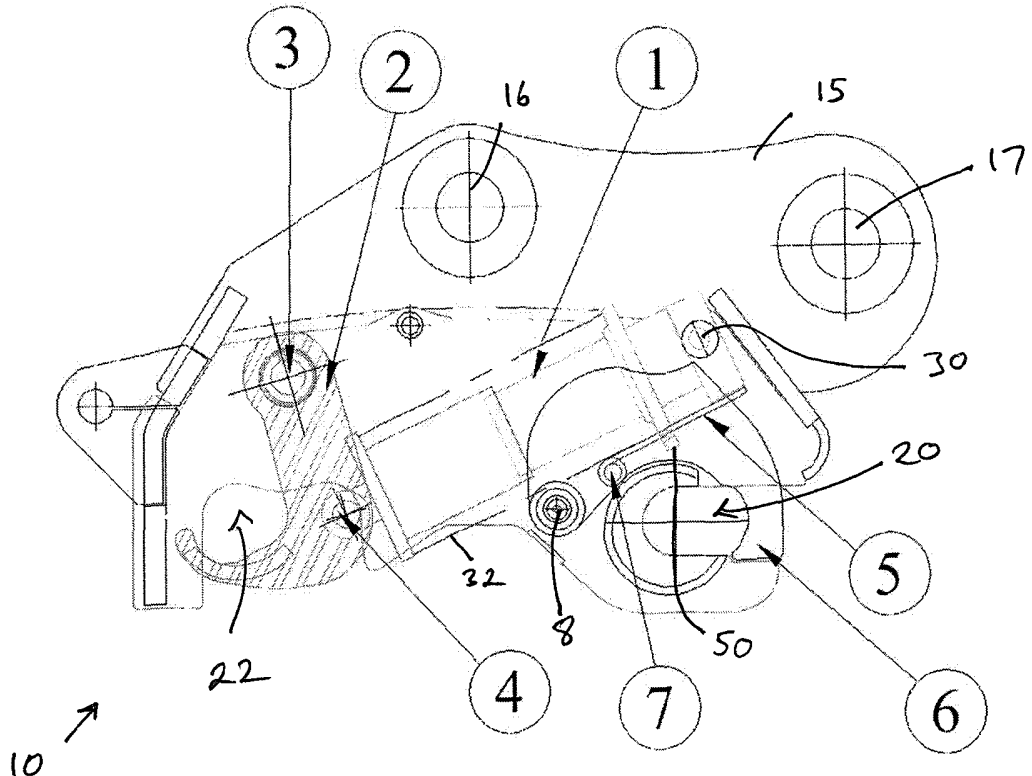

Figure 5

## Coupler

### Field of the Invention

- 5 The present invention relates to couplers for coupling an attachment, such as an excavating bucket, to the arm of an excavator. The invention relates particularly to couplers that are powered, especially hydraulically powered.

### Background to the Invention

10

Hydraulic couplers for quickly connecting and disconnecting construction attachments from excavating equipment are well known. A major problem with existing couplers is that a failure of the primary locking force, typically a hydraulic failure, can cause the attachment to swing or even completely detach from the coupler posing a safety hazard. Another problem is operator misuse or accidental operation of the coupler again leading to a safety hazard. Safety devices are fitted to couplers which prevent the attachment separating from the coupler in the event of a failure of the coupler or its associated locking components. However in all couplers there is little or no indication of a failure having taken place. Most of the couplers using a device to power the lock on the front pin receiving aperture use either a direct connection between the main actuator, which is normally a hydraulic cylinder, and the front lock or a separate hydraulic cylinder to actuate the front lock. Some couplers also use a linkage from the rear hook to actuate the front lock. The problem with all of these designs is that the front hook will retract when the cylinder is actuated. The use of a gravity pendulum device was disclosed in European Patent Application EP 2161378, which meant that the front lock would only be released in a certain coupler orientation. However for this pendulum device to work effectively it required the use of two hydraulic cylinders. An additional small bore hydraulic cylinder is fitted in the coupler to operate the front lock.

25

### Summary of the Invention

- 30 According to the present invention there is provided a coupler for an excavator, the coupler comprising a body having first and second recesses for receiving first and second pins, respectively, of an attachment; a latching member movable into and out of a latching state in which it at least partially or fully closes said second pin-receiving recess; and a blocking member movable into and out of a blocking state in which a portion of the blocking member at least partially closes said first recess, actuating means for moving said first latching member into and out of said latching state, said actuating means acting indirectly upon said blocking member to move said blocking member into and out of its blocking state as the latching member is moved into and out of its latching state.

35

- Preferably said actuating means acts upon said blocking member via a resiliently deformable member acting between the actuating means and the blocking member whereby said resiliently
- 40

deformable member can deflect should the blocking member be obstructed to avoid excessive loading on the actuating means.

5 In one embodiment said actuating means comprises a linear actuator having a first end coupled to the body of the coupler and a second end coupled to the latching member, the actuator and latching member being mounted such that the actuator pivots about its first end as the actuator is extended to move the latching member towards its latching state, altering the orientation of the actuator relative to the body of the coupler, the resiliently deformable member acting between the actuator and the blocking member whereby said change in orientation of the actuator causes that the blocking  
10 member to be urged towards its blocking state by means of the resiliently deformable member as the latching member moves towards its latching state under the action of the actuator.

Said pivotal movement of the actuator about its first end as the actuator is extended may cause at least a portion of the body of the actuator to be displaced towards the first recess.

15

Preferably the first end of the actuator is pivotally mounted on the body of the actuator adjacent the first recess, said latching member being pivotally mounted on the body of the actuator adjacent said second recess, the second end of the actuator being pivotally mounted on the latching member such that extension of the actuator moves the latching member towards its latching state.

20

The resiliently deformable member may comprise an elongate rod or bar having a first end mounted on or abutting said actuator and a second end mounted on or abutting said blocking member, wherein said deformable member extends substantially perpendicular to the direction of movement of the blocking member into and out of its blocking state. Preferably said resiliently deformable  
25 member extends substantially parallel to the actuator. The first end of the resiliently deformable member may be mounted on the actuator at or adjacent the first end of the actuator. The resiliently deformable member preferably extends towards the second end of the actuator, a distal end of the resiliently deformable member acting on the blocking member.

30 In preferred embodiments, said actuating means comprises an actuator, especially a linear actuator such as a ram, in particular a hydraulic ram, coupled to said latching member and arranged to actuate said latching member into and out of its latching state. Conveniently, said actuator is connected to the first latching member such that it acts directly thereon.

35 Advantageously, said actuator is provided with resilient biasing means arranged to urge said actuator into a state that corresponds with the latching state of the latching member. Typically, the actuator is arranged to hold said latching member in its latching state when in an extended state, and so the resilient biasing means is arranged to urge said actuator into its extended state.

Conveniently, the resilient biasing means comprises a spring, for example a compression spring.  
40 Typically, the force exerted by the resilient biasing means is less than the force exerted by the

actuator. Hence, failure of the actuator may allow movement of the first latching member against the bias of the resilient biasing means.

In preferred embodiments, at least one of the latching member and the blocking member are pivotal  
5 with respect to the body. Typically, at least one of the latching member and blocking member  
comprises a hook.

In the preferred embodiment, a blocking lever is mounted on the body and is movable into and out of  
a blocking state in which it is capable of obstructing the blocking member to prevent the blocking  
10 member from moving out of its blocking state.

Preferably, said blocking lever, which conveniently takes the form of a bar, is pivotally mounted on  
the body. In the preferred arrangement, the blocking lever hangs substantially vertically from a pivot  
point under the influence of gravity, the pivot point, preferably, being located substantially above said  
15 first recess when the coupler is in a normal working orientation.

Additionally a resiliently deformable member may be coupled to the blocking lever and arranged to  
engage with an arm of said excavator such that the action of the resiliently deformable member  
when engaged with the arm biases the blocking lever into its blocking state.

20

Preferably said latching member, when in the latching state, defines, or is movable to define,  
together with its respective recess, a station for said respective pin, said station being shaped and  
dimensioned to allow movement of said respective pin with respect to the coupler body, and wherein,  
in a first mode of use in which said latching member adopts said latching state, said respective pin is  
25 held under the action of said actuating means in a first position with respect to the body of the  
coupler, and in response to a failure or part failure of said actuating means, said respective pin is  
movable to said station.

When in said station, movement of the pin with respect to the coupler body creates a movement that  
30 is detectable by the operator and may be interpreted as an indication of failure of the actuating  
means.

In preferred embodiments, failure or part failure of said actuating means causes said latching  
member to move, conveniently in a direction towards its non-latching state (although while still  
35 maintaining its latching state), and said movement of said latching member allows the, or each,  
attachment pin, as applicable, to move into the respective station. In such cases, the respective  
attachment pin is held in its first position by the first latching member, said movement of the first  
latching member creating the respective station for the pin. Advantageously, said first latching  
member is shaped to define a recess, said recess in the latching member forming, together with the  
40 respective pin-receiving recess, said respective station upon said movement of the first latching  
member.

Typical couplers embodying the invention provide a means of quickly attaching, retaining and detaching implements, e.g. excavating buckets, from excavators, including backhoes and similar excavating or digging equipment. Typically, the couplers include a body with two attachment points  
5 for the excavator, two recesses for receiving the attachment pins, front and rear latching members, usually in the form of hook shaped levers, and a powered actuator to move the locking members. The latching members retain the attachment pins in the front and rear recesses of the coupler respectively. Each latching member advantageously retains the pins in position in the event of loss of the main engagement force of the actuator.

10

In preferred embodiments, means are provided for indicating via the normal use of a coupled attachment that a failure of the primary actuator within the coupler has occurred.

This invention uses the change of angle of the main actuator preferably a hydraulic cylinder mounted  
15 to the coupler body to operate the front lock. This is achieved via the use of a resiliently deformable member connected between the cylinder and the front lock in such a way that the change of angle of the main cylinder causes the operation of the front lock. The advantage of this is that if the front lock should be obstructed when opening or closing then the deformation of the connecting resiliently deformable member will allow this without excessive loads being imposed upon the pivots or  
20 linkages of the coupler mechanism. This allows the use of the previously disclosed gravity pendulum within a coupler employing a single actuator to lock and unlock both the front and rear locking members.

Further advantageous aspects of the invention will be apparent to a skilled person upon review of the  
25 following description of a preferred embodiment and with reference to the accompanying drawings.

#### Brief Description of the Drawings

An embodiment of the invention is now described by way of example and with reference to the  
30 accompanying drawings in which:

Figure 1 is side view of a coupler embodying the invention;

Figure 2 is a side view of the coupler of Figure 1 showing the latching member and blocking member  
35 in their respective open states;

Figure 3 is a side view of the coupler of Figure 1, showing a latching member and blocking member in their respective latching and blocking states;

40 Figure 4 is a sectional side view of a coupler in accordance with a further embodiment of the invention; and



Figure 5 is a side view of the coupler of Figure 4 showing the latching member and blocking member in their respective latching and blocking states.

## 5 Detailed Description of the Drawings

Referring now to the drawings there is shown, generally indicated as 10, a coupler, or hitch, for connecting a tool, or other attachment such as a bucket, to an arm of an excavator (not shown), or other apparatus. The coupler 10 has a body typically comprising two spaced-apart side plates 15 (only one shown). The body is shaped to define pin-receiving apertures 16, 17 by which the coupler 10 may be connected to the end of the arm. Typically, there are two spaced-apart apertures 16, 17 in each of the two side plates 15, the apertures in one side plate being aligned with the apertures in the other. When connected, the coupler 10 is able to pivot with respect to the arm about the axis of the apertures 17. Usually, a hydraulic mechanism, or other power operated mechanism (not shown), is provided, typically in association with a mechanical linkage and connected via aperture 16, to pivot the coupler 10 with respect to the arm.

The body includes first and second pin-receiving recesses 20, 22 formed in each side plate 15. Each recess 20, 22 is shaped and dimensioned to receive a respective pin 26 (see Figure 3) of a bucket or other attachment. Normally, the recesses 20, 22 face in mutually perpendicular directions. The recess 22 may be wider than is necessary to receive a single pin in order to accommodate attachments with different pin spacings.

The coupler 10 also includes a first power-operated latching mechanism typically comprising a latching member 2 in the preferred form of a hook, and an actuator 1 typically in the form of a linear actuator such as a hydraulic ram. Other forms of powered actuator could be used (e.g. pneumatic or electrically operated) but hydraulic is convenient because excavators typically have a hydraulic system available at or near the end of the arm. The latching member 2 and actuator 1 are provided between the side plates 15. The latching member 2, which may comprise one or more aligned hook elements, is pivotally mounted on the body at pivot 3 in any convenient manner and is pivotal about an axis that runs substantially perpendicular to the body/plates 15. The latching member 2 is pivotal between an open, or non-latching, state (shown in Figure 2) and at least one latching state (shown in Figure 3). In the open state, the latching member 2 allows a respective pin to be inserted into or removed from the recess 22. In the latching state, the latching member 2 prevents the pin from being removed from the recess 22. For example, in Figure 2, the latching member 2 is shown in the open non-latching state while in Figure 3 the latching member 2 is shown in its latching state. In its latching state the latching member 2 may partially or fully close the recess 22.

The coupler 10 further includes a front blocking member 6, in the preferred form of a hook, for retaining an attachment pin in the recess 20. The blocking member 6 is pivotally mounted on the body in any convenient manner, e.g. pin or bearing, at pivot point 8. The blocking member 6 is

pivotal about an axis substantially perpendicular to the side plates 15 between an open state (Figure 2) and a blocking state (Figure 3). In the open state, the blocking member 6 is clear of the recess 20 to the extent that it does not prevent the respective pin from being removed from the recess 20, while in the blocking state, the blocking member 6 prevents the pin from being removed from the recess 20. In the preferred embodiment, the blocking member 6 includes a jaw that, in the blocking state, substantially, or at least partly, closes the otherwise open mouth of the recess 20. In alternative embodiments, the blocking member 6 may be slidably mounted on the body, or otherwise movable between the open state and the blocking state(s), without necessarily being pivotal. Further, the blocking member 6 need not necessarily take the form of a hook.

10

Typically, the actuator 1 comprises a piston housing and a piston rod, the rod being actuatable into and out of the housing in a reciprocating manner. In the preferred embodiment, the free, or leading, end of the piston rod is pivotally connected to the latching member 2, the pivoting movement being about a respective axis 4 that is substantially perpendicular to the plates 15. A rear end of the piston housing is pivotally connected to the housing for pivotal movement about a respective pivot axis 30 adjacent the recess 20. When the piston rod adopts a retracted state, or relatively retracted state, the latching member 2 adopts its open state as shown in Figure 2. When the piston rod is extended, the latching member moves towards its latching state, as shown in Figure 3. Depending on the location of the respective pin 26 in the recess 22, the amount by which the piston rod is extended when the latching member 2 reaches its latching state can vary. Conveniently, the actuator 1 is operable via the excavator's hydraulic system (not shown), the controls typically being located in the cab of the excavator.

Advantageously, resilient biasing means, conveniently in the form of a spring 32 may be provided on the actuator 1 and arranged to resiliently bias the actuator 1, and in particular the piston rod, into its extended position. The spring 32 may take the form of a compression spring. The spring 32 is shown externally of the actuator 1. Alternatively, the spring 32, or other resilient biasing means, may be fitted internally of the piston housing. The biasing means may be a mechanical spring as illustrated but may take any suitable alternative form, e.g. a gas spring. The purpose of the spring 32 is to hold the actuator 1 in its extended state and so to hold the latching member 2 in a forward or latching state in the event of the loss of actuating force from the actuator 1 due, for example, to a hydraulic or mechanical failure of the actuator 1 or its supply. This may be regarded as a redundant safety back up to the extension force of the actuator 1. In use, the actuator 1 together with the spring 32, when present, provide a primary actuating force that serves to hold the first latching member 2 in its latching state.

In preferred embodiments, the coupler 10 includes a gravity-actuated blocking member in the preferred form of a pivotally mounted blocking lever 9 (see Figures 2 and 3) and is movable between a blocking state and a non-blocking state depending upon the orientation of the coupler body. In the blocking state, the blocking lever 9, or at least its free end, lies in the path of the blocking member 6 such that it prevents the blocking member 6 from moving from its blocking state to its open state.

40

The blocking lever 9 is pivotal with respect to the coupler body between the blocking and non-blocking states under the action of gravity.

In the preferred embodiment, the arrangement is such that the blocking lever 9 is located over the front pin receiving recess 20 when the coupler body is in a normal operating orientation during use of the attachment mounted thereon so that the blocking lever 9 hangs substantially vertically in the blocking state to prevent movement of the blocking member 6 away from its blocking state. It is also preferred that a gap is left between the free end of the blocking lever 9 and the blocking member 6 when the blocking lever is in its blocking state to obviate the risk of the blocking lever jamming against the blocking member during use by, for example, dirt or other foreign matter. The gap also provides a self-cleaning effect whereby the movement of the blocking lever 9 swinging into and out of its blocking state during the normal use of the coupler, will tend to prevent any build up of debris on the of the blocking member 6. Further, the gap between the blocking lever 9 and the blocking member 6 is advantageous in that it allows some flexibility in the operation of the coupler 10: should the operator initiate the withdrawal of the blocking member 6 before pivoting the coupler 10 into a different orientation, then provided he initiates the pivoting of the coupler a short time later, the blocking member 6 will not be blocked by the blocking lever 9.

In the event of a failure of the primary latching force to the first latching member 2, e.g. in the event of a hydraulic failure of the actuator 1, in a coupler orientation where the attachment will have a tendency to try to escape from the front recess 20 due to the action of gravity, the blocking member 6 is locked in position mechanically by the position of the gravity-actuated blocking lever. To ensure that the blocking lever is in position to block any movement of the blocking member 6, especially in cases where gravity tends to urge the front attachment pin from recess 20, the blocking lever 9 may be provided with a resiliently deformable member (not shown) arranged to engage with an arm of an excavator or other machine to which the coupler is mounted during use in certain orientations. In particular, it is preferably arranged to engage with the dipper arm (or other part) of the excavator when the coupler is in the full curl or dump position. The arrangement is such that the action of the resiliently deformable member when engaged with the arm will bias the gravity blocking lever 9 into its blocking state, thereby preventing movement of the blocking member 6 away from its blocking state. Conveniently, when the blocking lever is in the non-blocking state, its position is determined by a mechanical stop against which it comes to rest.

In the preferred embodiment the actuator 1 acts indirectly upon the blocking member 6 via a resiliently deformable member 5. The resiliently deformable member 5 is conveniently connected to or acts against (directly or indirectly) the blocking member 6 at one end as is connected to or acts against the actuator 1 at an opposite end. In the embodiment shown in Figures 2 and 3, the resiliently deformable member 5 is mounted on an extension of the piston housing of actuator 1. This extension is shown as being close to pivot 30 of actuator 1 but may be positioned in any suitable position along the length of actuator 1. This resiliently deformable member 5, in the form of a rod or bar of resilient material, such as spring steel, extends substantially parallel to the piston rod of

the actuator 1 to engage a portion of the blocking member 6. In the embodiment shown, the resiliently deformable member 5 comprises an elongate strip formed from spring steel having a retained end attached to the extension of the piston housing of actuator 1 and a section which may be straight or curved or any combination extending therefrom to pass through a receiving aperture in a member 7. Member 7 may be pivotally mounted on front blocking member 6 or alternatively permanently fixed to front blocking member 6 such that any movement of the resiliently deformable member 5 is transferred into front blocking member 6. By way of example, the resiliently deformable member 5 may comprise a leaf spring.

10 As the actuator 1 extends, this causes latching member 2 to rotate around its fixed pivot point 3. This rotation of the latching member 2 combined with the extension of actuator 1 causes the angle of the actuator 1 within the coupler body to change as the piston rod follows the arc described by its attachment point 4 to latching member 2. This change in angle is translated via the resiliently deformable member 5 into a vertical movement of the deformable members attachment point 7 to  
15 the front blocking member 6. The result of this is that the front blocking member 6 is caused to rotate around its pivot 8 to the coupler body. The mechanism is designed such that extension of the actuator 1 will cause the front blocking member 6 to move to its blocking position closing the front pin receiving recess 20 of the coupler. Equally, retraction of the actuator 1 will cause the front blocking member 6 to move to a position clear of the front pin receiving recess 20 effectively opening the front  
20 recess 20 of the coupler

An additional benefit of the use of the resiliently deformable member 5 is that, should the movement of the front blocking member 6 be obstructed e.g. by the gravity blocking lever 9 previously described, then the movement caused by the change in extension of the actuator 1 will cause a  
25 deformation of the resiliently deformable member 5 and not impose any excessive loading upon any pivots or linkages within the coupler mechanism.

In an alternative embodiment, illustrated in Figures 4 and 5, the resiliently deformable member comprising an elongate strip or rod, for example formed from spring steel, having a retained (e.g.  
30 coiled) end attached to the mounting pin 7 of the latching member 2 and a straight section extending therefrom and passing through a receiving aperture 50 formed in a projection provided on the actuator body. A distal end of the straight section of the resiliently deformable member 5 may abut against a side of the actuator 1 adjacent its pivot point 30.

35 The invention is not limited by the embodiment described herein, which may be modified or varied without departing from the scope of the invention.

Claims

1. A coupler for an excavator, the coupler comprising a body having first and second recesses for receiving first and second pins, respectively, of an attachment; a latching member movable into  
5 and out of a latching state in which it at least partially closes said second pin-receiving recess; and a blocking member movable into and out of a blocking state in which a portion of the blocking member at least partially or fully closes said first recess, actuating means for moving said first latching  
member into and out of said latching state, said actuating means acting indirectly upon said blocking  
member to move said blocking member into and out of its blocking state as the latching member is  
10 moved into and out of its latching state.

2. A coupler as claimed in claim 1, wherein said actuating means acts upon said blocking member via a resiliently deformable member acting between the actuating means and the blocking member whereby said resiliently deformable member can deflect should the blocking member be  
15 obstructed to avoid excessive loading on the actuating means.

3. A coupler as claimed in claim 2, wherein said actuating means comprises a linear actuator having a first end coupled to the body of the coupler and a second end coupled to the latching member, the actuator and latching member being mounted such that the actuator pivots about its  
20 first end as the actuator is extended to move the latching member towards its latching state, altering the orientation of the actuator relative to the body of the coupler, the resiliently deformable member acting between the actuator and the blocking member whereby said change in orientation of the actuator causes that the blocking member to be urged towards its blocking state by means of the resiliently deformable member as the latching member moves towards its latching state under the  
25 action of the actuator.

4. A coupler as claimed in claim 3, wherein said pivotal movement of the actuator about its first end as the actuator is extended causes at least a portion of the body of the actuator to be displaced towards the first recess.  
30

5. A coupler as claimed in claim 3 or claim 4, wherein the first end of the actuator is pivotally mounted on the body of the actuator adjacent the first recess, said latching member being pivotally mounted on the body of the actuator adjacent said second recess, the second end of the actuator being pivotally mounted on the latching member such that extension of the actuator moves the  
35 latching member towards its latching state.

6. A coupler as claimed in any of claims 3 to 5, wherein said resiliently deformable member comprises an elongate rod or bar having a first end mounted on or abutting said actuator and a second end mounted on or abutting said blocking member, wherein said deformable member  
40 extends substantially perpendicular to the direction of movement of the blocking member into and out of its blocking state.

7. A coupler as claimed in claim 6, wherein said resiliently deformable member extends substantially parallel to the actuator.
- 5 8. A coupler as claimed in claim 6 or claim 7, wherein the first end of the resiliently deformable member is mounted on the actuator at or adjacent the first end of the actuator.
9. A coupler as claimed in claim 8, wherein the resiliently deformable member extends towards the second end of the actuator, a distal end of the resiliently deformable member acting on the  
10 blocking member.
10. A coupler as claimed in any preceding claim, wherein the latching member and/or the blocking member is pivotally coupled to the body of the coupler.
- 15 11. A coupler as claimed in claim 10, wherein the latching member and /or the blocking member comprises a hook.
12. A coupler as claimed in claim 10 or claim 11, wherein the blocking member is pivotally coupled to the body of the coupler at a location between the first and second recesses.  
20
13. A coupler as claimed in any preceding claim, wherein said actuating means comprises a hydraulic ram.
14. A coupler as claimed in any preceding claim, wherein a blocking lever is mounted on the  
25 body and is movable into and out of a blocking state in which it is capable of obstructing the blocking member to prevent the blocking member from moving out of its blocking state.
15. A coupler as claimed in claim 14, wherein said blocking lever is pivotally mounted on the  
30 body.
16. A coupler as claimed in claim 15, wherein the blocking lever hangs substantially vertically from a pivot point under the influence of gravity, the pivot point being located substantially above said first recess when the coupler is in a normal working orientation.
- 35 17. A coupler as claimed in any preceding claim, wherein said latching member, when in the latching state, defines, or is movable to define, together with its respective recess, a station for said respective pin, said station being shaped and dimensioned to allow movement of said respective pin with respect to the coupler body, and wherein, in a first mode of use in which said latching member adopts said latching state, said respective pin is held under the action of said actuating means in a  
40 first position with respect to the body of the coupler, and in response to a failure or part failure of said actuating means, said respective pin is movable to said station such that, when in said station,

movement of the pin with respect to the coupler body creates a rattle that is detectable by the operator and may be interpreted as an indication of failure of the actuating means.

18. A coupler substantially as herein described with reference to the accompanying drawings.

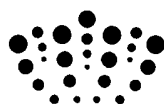

**Application No:** GB1017366.4

**Examiner:** Mr Colin Walker

**Claims searched:** 1 to 18

**Date of search:** 25 January 2011

**Patents Act 1977: Search Report under Section 17**

**Documents considered to be relevant:**

Category	Relevant to claims	Identity of document and passage or figure of particular relevance
X	1 to 18	EP2119834 A2 (MANTOVANI) - See figures 3 and 4 and paragraphs 28 to 30 in particular.
X	1 to 18	EP2076631 A2 (HILL) - See figures 4 to 7 and paragraphs 8 to 13.
X	1 to 18	US2009/007465 A1 (ROBL et al) - See figures 3 and 4 in particular and paragraphs 17 to 19, 24 to 28 and 33.
X	1 to 18	GB2463298 A (MILLER) - See figures 1 and 2 and page 15 line 4 to page 17 line 2.
X,P	1	GB2467380 A (MILLER et al) - See figures and page 7 line 1 to 9.

**Categories:**

X	Document indicating lack of novelty or inventive step	A	Document indicating technological background and/or state of the art.
Y	Document indicating lack of inventive step if combined with one or more other documents of same category.	P	Document published on or after the declared priority date but before the filing date of this invention.
&	Member of the same patent family	E	Patent document published on or after, but with priority date earlier than, the filing date of this application.

**Field of Search:**

Search of GB, EP, WO & US patent documents classified in the following areas of the UKC<sup>X</sup> :

Worldwide search of patent documents classified in the following areas of the IPC

E02F

The following online and other databases have been used in the preparation of this search report

Online : WPI, EPODOC

**International Classification:**

Subclass	Subgroup	Valid From
E02F	0003/36	01/01/2006