

(19) World Intellectual Property Organization
International Bureau



(43) International Publication Date
7 August 2008 (07.08.2008)

PCT

(10) International Publication Number
WO 2008/095196 A1

- (51) International Patent Classification:
B01D 46/52 (2006.01)
- (21) International Application Number:
PCT/US2008/052961
- (22) International Filing Date: 4 February 2008 (04.02.2008)
- (25) Filing Language: English
- (26) Publication Language: English
- (30) Priority Data:
60/899,311 2 February 2007 (02.02.2007) US
- (71) Applicant (for all designated States except US): **DON-ALDSON COMPANY, INC.** [US/US]; 1400 West 94th Street, P.o. Box 1299, Minneapolis, MN 55440-1299 (US).
- (72) Inventors; and
- (75) Inventors/Applicants (for US only): **ROCKLITZ, Gary, J.** [US/US]; 12724 Diamond Drive, Burnsville, MN 55337 (US). **OUYANG, Ming** [US/US]; 2211 Draper Avenue, Roseville, MN 55113 (US). **MATHEW, Anitha, M.** [US/US]; 11256 Providence Lane, Eden Prairie, MN 55344 (US).

- (74) Agent: **BRUESS, Steven, C.**; Merchant & Gould P.c., P.o. Box 2903, Minneapolis, MN 55402-0903 (US).
- (81) Designated States (unless otherwise indicated, for every kind of national protection available): AE, AG, AL, AM, AO, AT, AU, AZ, BA, BB, BG, BH, BR, BW, BY, BZ, CA, CH, CN, CO, CR, CU, CZ, DE, DK, DM, DO, DZ, EC, EE, EG, ES, FI, GB, GD, GE, GH, GM, GT, HN, HR, HU, ID, IL, IN, IS, JP, KE, KG, KM, KN, KP, KR, KZ, LA, LC, LK, LR, LS, LT, LU, LY, MA, MD, ME, MG, MK, MN, MW, MX, MY, MZ, NA, NG, NI, NO, NZ, OM, PG, PH, PL, PT, RO, RS, RU, SC, SD, SE, SG, SK, SL, SM, SV, SY, TJ, TM, TN, TR, TT, TZ, UA, UG, US, UZ, VC, VN, ZA, ZM, ZW.
- (84) Designated States (unless otherwise indicated, for every kind of regional protection available): ARIPO (BW, GH, GM, KE, LS, MW, MZ, NA, SD, SL, SZ, TZ, UG, ZM, ZW), Eurasian (AM, AZ, BY, KG, KZ, MD, RU, TJ, TM), European (AT, BE, BG, CH, CY, CZ, DE, DK, EE, ES, FI, FR, GB, GR, HR, HU, IE, IS, IT, LT, LU, LV, MC, MT, NL, NO, PL, PT, RO, SE, SI, SK, TR), OAPI (BF, BJ, CF, CG, CI, CM, GA, GN, GQ, GW, ML, MR, NE, SN, TD, TG).

Published:

- with international search report
- before the expiration of the time limit for amending the claims and to be republished in the event of receipt of amendments

(54) Title: AIR FILTRATION MEDIA PACK, FILTER ELEMENT, AIR FILTRATION MEDIA, AND METHODS

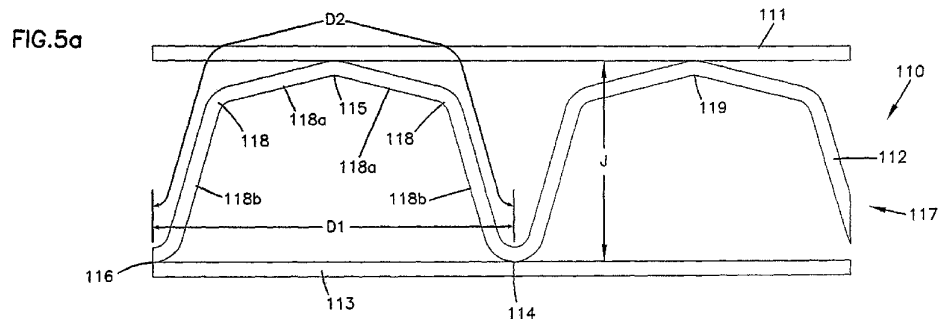

(57) Abstract: An air filtration media pack is provided having a plurality of layers of single facer media. The layer of single facer media includes a fluted sheet, a facing sheet, and a plurality of flutes extending between the fluted sheet and the facing sheet and having a flute length extending from a first face of the filtration media pack to a second face of the filtration media pack. A first portion of the plurality of flutes are closed to unfiltered air flowing into the first portion of the plurality of flutes, and a second portion of the plurality of flutes are closed to unfiltered air from flowing out of the second portion of the plurality of flutes so that air passing into one of the first face and the second face of the media pack and out the other of the first face and the second face of the media pack passes through media to provide filtration of the air. The fluted sheet includes repeating internal peaks facing toward the facing sheet and repeating external peaks facing away from the facing sheet. In addition, the fluted sheet can include at least one ridge extending along at least 50% of the flute length between an internal peak and an adjacent external peak. Additional characterizations of an air filtration media pack, air filtration media, and methods of making and using are provided.



WO 2008/095196 A1

**AIR FILTRATION MEDIA PACK, FILTER ELEMENT,
AIR FILTRATION MEDIA, AND METHODS**

This application is being filed on 04 February 2008, as a PCT International Patent application in the name of DONALDSON COMPANY, INC., a
5 U.S. national corporation, applicant for the designation of all countries except the U.S., and Gary J. ROCKLITZ, a citizen of the U.S., Ming OUYANG, a citizen of the U.S., and Anitha M. MATHEW, a citizen of the U.S., applicants for the designation of the U.S. only, and claims priority to U.S. Provisional Patent Application Serial No. 60/899,311 filed on 02 February 2007.

10

Field of the Invention

The present invention relates to an air filtration media pack that can be used to form filter elements for cleaning air. The invention additionally relates to filter elements, air filtration media, and methods for manufacturing and using.

Background

15

Fluid streams, such as air and liquid, carry contaminant material therein. In many instances, it is desired to filter some or all of the contaminant materials from the fluid stream. For example, air flow streams to engines for motorized vehicles or for power generation equipment, gas streams to gas turbine systems and air streams to various combustion furnaces, carry particulate
20 contaminants therein that should be filtered. Also liquid streams in engine lube systems, hydraulic systems, coolant systems or fuel systems, can carry contaminants that should be filtered. It is preferred for such systems, that selected contaminant material be removed from (or have its level reduced in) the fluid. A variety of fluid filter (air or liquid filter) arrangements have been developed for contaminant
25 reduction. In general, however, continued improvements are sought.

25

Z-media generally refers to a type of fluted filtering media where a fluid enters flutes on a first face of the media and exits from flutes at a second face of the media. In general, the faces on z-media are provided on opposite ends of the media. The fluid enters through open flutes on one face and exits through open
30 flutes on the other face. At some point between the first face and the second face, the fluid passes from one flute to another flute to provide for filtration.

Early forms of z-media were often referred to as corrugated media because the characterization of the media was adopted from the corrugated box board industry. Corrugated box boards, however, were generally designed for carrying a load. Accordingly, flute designs can be modified away from the standards and sizes from the corrugated box board industry to provide improved media performance.

Various disclosures have been provided for modifying the form of the flutes in z-media. For example, U.S. Patent No. 5,562,825 describes corrugation patterns which utilize somewhat semicircular (in cross section) inlet flutes adjacent narrow V-shaped (with curved sides) exit flutes are shown (see Figs. 1 and 3, of U.S. Patent No. 5,562,825). In U.S. Patent No. 5,049,326 to Matsumoto et al., circular (in cross-section) or tubular flutes defined by one sheet having half tubes attached to another sheet having half tubes, with flat regions between the resulting parallel, straight, flutes are shown. See Fig. 2 of U.S. Patent No. 5,049,326. U.S. Patent No. 4,925,561 to Ishii et al. (Fig. 1) shows flutes folded to have a rectangular cross section, in which the flutes taper along their lengths. In WO 97/40918 (FIG. 1), flutes or parallel corrugations which have a curved, wave patterns (from adjacent curved convex and concave troughs) but which taper along their lengths (and thus are not straight) are shown. Also, in WO 97/40918 flutes which have curved wave patterns, but with different sized ridges and troughs, are shown.

Summary

An air filtration media pack is provided according to the present invention. The air filtration media pack includes a plurality of layers of single facer media. A layer of single facer media comprises a fluted sheet, a facing sheet, and a plurality of flutes extending between the fluted sheet and the facing sheet and having a flute length extending from a first face of the filtration media pack to a second face of the filtration media pack. A first portion of the plurality of flutes are closed to unfiltered air flowing into the first portion of the plurality of flutes, and a second portion of the plurality of flutes are closed to unfiltered air flowing out of the second portion of the plurality of flutes so that air passing into one of the first face and the second face of the media pack and out the other of the first face and the second face of the media pack passes through media to provide filtration of the air. The fluted

sheet includes repeating internal peaks facing toward the facing sheet and repeating external peaks facing away from the facing sheet. In addition, the fluted sheet includes a repeating pattern of flutes comprising a flute having at least one ridge extending along at least a portion of the flute length between an internal peak and an adjacent external peak. Preferably, the repeating pattern of flutes comprises a flute having at least one ridge extending at least 50% of the flute length between an internal peak and adjacent external peak.

The repeating pattern of flutes can comprise any number of flutes where the pattern repeats itself. The number of flutes can include one flute, two flutes, three flutes, four flutes, etc. At a location within the repeating pattern, there is at least one ridge extending between an internal peak and an adjacent external peak. It is possible that there is a ridge extending between every internal peak and adjacent external peak, but that is not necessary. A repeating pattern may include flutes or portions of flutes that do not include a ridge extending between an internal peak and an adjacent external peak. In the case where the fluted sheet includes a flute having a ridge extending between an internal peak and an adjacent external peak for a flute period, that flute period can be referred to as having a "low contact" shape. When the fluted sheet includes two ridges extending between an internal peak and an adjacent external peak for a flute period, the shape of the flute period can be referred to as "zero strain." While it is desirable to provide a ridge extending between every adjacent peak, that is not necessary. It is possible that the repeating pattern has one or more ridge extending between adjacent peaks, and one or more area between adjacent peaks that do not include a ridge.

To obtain the benefit of having a ridge extend between adjacent peaks, it can be desirable to have the ridge extend a length of at least 20% of the flute length. Preferably, the ridge extends at least 40% of the flute length, at least 50% of the flute length, or at least 80% of the flute length.

An air filtration media pack is provided according to the present invention that can be characterized as z-media containing flutes wherein the flutes contain an enhanced amount of media between adjacent flutes. Techniques for characterizing the amount of filtration media between adjacent peaks include reference to a cord-media percentage and reference to a flute width height ratio. For a filtration media pack according to the invention, the cord-media percentage can be

at least about 6.2% and the flute width height ratio can be greater than about 2.2 or less than about 0.45. In addition, the filtration media pack according to the invention can be characterized as having a volume on one side of the media pack that is greater than a volume on another side of the media pack by at least 10%, and
5 wherein the flute width height ratio can be greater than about 2.2 or less than about 0.45.

A fluted media sheet is provided according to the present invention. The fluted media sheet includes a repeating pattern of flutes comprising internal peaks and external peaks. The repeating pattern of flutes includes at least one ridge
10 extending along at least 50% of a flute length between an internal peak and an adjacent external peak. The media comprises a cellulose based media for fluid filtration.

Methods for forming the air filtration media pack and for using the air filtration media pack are provided.

15

Brief Description of the Drawings

Figure 1 is a fragmentary, schematic, perspective view of an exemplary z-filtration media according to the prior art.

Figure 2 is an enlarged schematic, cross-sectional view of a portion of the prior art media depicted in Figure 1.

20

Figure 3 is a schematic view of various corrugated media definitions.

Figures 4a-c are enlarged schematic, cross-sectional views of a portion of media illustrating the width height ratio.

Figures 5a-5c are enlarged schematic, cross-sectional views of a portion of media according to the present invention.

25

Figure 6 is a photograph showing an end view of wound filtration media according to Figure 5a.

Figure 7 is a photograph showing a perspective view of dust loaded into the filtration media shown in Figure 6 wherein a portion of the fluted sheet is peeled back to reveal a dust cake.

30

Figure 8 is a perspective view of a tapered fluted sheet of the media according to Figure 5b.

Figures 9a and 9b are a series of sectional views of a tapered media according to Figures 5b and 5c.

Figures 10a and 10b are enlarged schematic, cross-sectional views of a portion of asymmetric media according to the present invention.

5 Figure 11 is a cross-sectional view of a flute after contact with an inverter wheel and before contact with a folder wheel for closure of the flute.

Figure 12 is a cross-sectional view of a flute taken along line 12-12 of Figure 11.

10 Figure 13 is a cross-sectional view of a flute taken along line 13-13 of Figure 9.

Figure 14 is a cross-sectional view of a flute after contact with a folder wheel.

Figure 15 is a cross-sectional view of a flute taken along line 15-15 of Figure 14.

15 Figure 16 is a cross-sectional view of a flute taken along line 16-16 of Figure 14.

Figure 17 is a cross-sectional view of a flute taken along line 17-17 of Figure 14.

Figure 18 is an end view of a folded flute depicted in Figure 14.

20 Figure 19 is a sectional view of an exemplary air cleaner that can include a filter element containing the air filtration media pack according to the present invention.

Figure 20 is a partial, sectional view of a filter element containing an air filtration media pack according to the present invention.

25 Figure 21 is a perspective view of a filter element containing an air filtration media pack according to the present invention.

Figure 22 is a perspective view of a filter element containing an air filtration media pack according to the present invention.

30 22. Figure 23 is a bottom, perspective view of the filter element of Figure 22.

Figure 24 is a side view of the sensor board of the filter element of Figures 22 and 23.

Figure 25 is a partial, sectional view of a filter arrangement containing an air filtration media pack according to the present invention.

Figure 26 is a partial, sectional view of an air cleaner having a filter element containing an air filtration media pack according to the present invention.

5 Figure 27 is a perspective view of an exemplary filter element containing an air filtration media pack according to the present invention.

Figure 28 is a perspective view of an exemplary filter element containing an air filtration media pack according to the present invention.

Detailed Description

10 **Fluted Filtration Media**

Fluted filtration media can be used to provide fluid filter constructions in a variety of manners. One well known manner is as a z-filter construction. The terms “z-filter construction” or “z-filter media” as used herein, is meant to refer to a filter construction in which individual ones of corrugated, folded, pleated, or otherwise formed filter flutes are used to define longitudinal filter flutes for fluid flow through the media; the fluid flowing along the flutes between inlet and outlet flow ends (or flow faces) of the media. Some examples of z-filter media are provided in U.S. Patent Nos. 5,820,646; 5,772,883; 5,902,364; 5,792,247; 15 5,895,574; 6,210,469; 6,190,432; 6,350,296; 6,179,890; 6,235,195; Des. 399,944; 20 Des. 428,128; Des. 396,098; Des. 398,046; and, Des. 437,401; each of these fifteen cited references being incorporated herein by reference.

One type of z-filter media utilizes two media components joined together to form the media construction. The two components are: (1) a fluted (for example, corrugated) media sheet; and, (2) a facing media sheet. The facing media sheet is typically non-corrugated, however it can be corrugated, for example 25 perpendicularly to the flute direction as described in International Publication No. WO 2005/077487, published August 25, 2005, incorporated herein by reference. Alternatively, the facing sheet can be a fluted (for example, corrugated) media sheet and the flutes or corrugations may be aligned with or at angles to the fluted media 30 sheet. Although the facing media sheet can be fluted or corrugated, it can be provided in a form that is not fluted or corrugated. Such a form can include a flat

sheet. When the facing media sheet is not fluted, it can be referred to as a non-fluted media sheet or as a non-fluted sheet.

The type of z-filter media that utilizes two media components joined together to form the media construction wherein the two components are a fluted media sheet and a facing media sheet can be referred to as a single facer media. In certain z-filter media arrangements, the single facer media (the fluted media sheet and the facing media sheet), together, can be used to define media having parallel inlet and outlet flutes. In some instances, the fluted sheet and non-fluted sheet are secured together and are then coiled to form a z-filter media construction. Such arrangements are described, for example, in U.S. Patent No. 6,235,195 and U.S. Patent No. 6,179,890, each of which is incorporated herein by reference. In certain other arrangements, some non-coiled sections of fluted media secured to flat media, are stacked on one another, to create a filter construction. An example of this is described in Fig. 11 of U.S. Patent No. 5,820,646, incorporated herein by reference. In general, arrangements where the z-filter media is coiled can be referred to as coiled arrangements, and arrangements where the z-filter media is stacked can be referred to as stacked arrangements. Filter elements can be provided having coiled arrangements or stacked arrangements.

Typically, coiling of the fluted sheet/facing sheet combination (e.g., the single facer media) around itself, to create a coiled media pack, is conducted with the facing sheet directed outwardly. Some techniques for coiling are described in International Publication No. WO 2004/082795, published September 30, 2004, incorporated herein by reference. The resulting coiled arrangement generally has, as the outer surface of the media pack, a portion of the facing sheet, as a result.

The term "corrugated" used herein to refer to structure in media, is meant to refer to a flute structure resulting from passing the media between two corrugation rollers, i.e., into a nip or bite between two rollers, each of which has surface features appropriate to cause a corrugation affect in the resulting media. The term "corrugation" is not meant to refer to flutes that are formed by techniques not involving passage of media into a bite between corrugation rollers. However, the term "corrugated" is meant to apply even if the media is further modified or deformed after corrugation, for example by the folding techniques described in PCT WO 04/007054, published January 22, 2004, incorporated herein by reference.

Corrugated media is a specific form of fluted media. Fluted media is media which has individual flutes (for example, formed by corrugating or folding or pleating) extending thereacross. Fluted media can be prepared by any technique that provides the desired flute shapes. Corrugating can be a useful technique for forming
5 flutes having a particular size. When it is desirable to increase the height of the flutes (the height is the elevation between peaks), corrugating techniques might not be practical and it may be desirable to fold or pleat the media. In general, pleating of media can be provided as a result of folding the media. An exemplary technique for folding the media to provide pleats includes scoring and using pressure to create
10 the fold.

Filter element or filter cartridge configurations utilizing z-filter media are sometimes referred to as "straight through flow configurations" or by variants thereof. In general, in this context what is meant is that the serviceable filter elements generally have an inlet flow end (or face) and an exit flow end (or face),
15 with flow entering and exiting the filter cartridge in generally the same straight through direction. The term "straight through flow configuration" disregards, for this definition, air flow that passes out of the media pack through the outermost wrap of facing media. In some instances, each of the inlet flow end and outlet flow end can be generally flat or planar, with the two parallel to one another. However,
20 variations from this, for example non-planar faces, are possible in some applications. Furthermore, the characterization of an inlet flow face and an opposite exit flow face is not a requirement that the inlet flow face and the outlet flow face are parallel. The inlet flow face and the exit flow face can, if desired, be provided as parallel to each other. Alternatively, the inlet flow face and the outlet flow face can be provided at
25 an angle relative to each other so that the faces are not parallel. In addition, non-planar faces can be considered non-parallel faces.

A straight through flow configuration is, for example, in contrast to cylindrical pleated filter cartridges of the type shown in U.S. Patent No. 6,039,778, in which the flow generally makes a substantial turn as its passes through the
30 serviceable cartridge. That is, in a U.S. Patent No. 6,039,778 filter, the flow enters the cylindrical filter cartridge through a cylindrical side, and then turns to exit through an end face in a forward-flow system. In a reverse-flow system, the flow enters the serviceable cylindrical cartridge through an end face and then turns to exit

through a side of the cylindrical filter cartridge. An example of such a reverse-flow system is shown in U.S. Patent No. 5,613,992.

The filter element or filter cartridge can be referred to as a serviceable filter element or filter cartridge. The term "serviceable" in this context is meant to refer to a media containing filter cartridge that is periodically removed and replaced from a corresponding air cleaner. An air cleaner that includes a serviceable filter element or filter cartridge is constructed to provide for the removal and replacement of the filter element or filter cartridge. In general, the air cleaner can include a housing and an access cover wherein the access cover provides for the removal of a spent filter element and the insertion of a new or cleaned (reconditioned) filter element.

The term "z-filter media construction" and variants thereof as used herein, without more, is meant to refer to any or all of: a single facer media containing a fluted media sheet and a facing media sheet with appropriate closure to inhibit air flow from one flow face to another without filtering passage through the filter media; and/or, a single facer media that is coiled or stacked or otherwise constructed or formed into a three dimensional network of flutes; and/or, a filter construction including a single facer media; and/or, a fluted media constructed or formed (e.g., by folding or pleating) into a three dimensional network of flutes. In general, it is desirable to provide an appropriate flute closure arrangement to inhibit unfiltered air that flows in one side (or face) of the media from flowing out the other side (or face) of the media as part of the filtered air stream leaving the media. In many arrangements, the z-filter media construction is configured for the formation of a network of inlet and outlet flutes, inlet flutes being open at a region adjacent an inlet face and being closed at a region adjacent an outlet face; and, outlet flutes being closed adjacent an inlet face and being open adjacent an outlet face. However, alternative z-filter media arrangements are possible, see for example US 2006/0091084 A1, published May 4, 2006 to Baldwin Filters, Inc. also comprising flutes extending between opposite flow faces, with a seal arrangement to prevent flow of unfiltered air through the media pack. In many z-filter constructions according to the invention, adhesive or sealant can be used to close the flutes and provide an appropriate seal arrangement to inhibit unfiltered air from flowing from one side of the media to the other side of the media. Plugs, folds of media, or a

crushing of the media can be used as techniques to provide closure of flutes to inhibit the flow of unfiltered air from one side of the media (face) to the other side of the media (face).

5 An alternative z-filter construction can be provided utilizing a fluted media sheet. For example, the fluted media sheet can be folded to create closures at the inlet flow face and exit flow face. An example of this type of arrangement can be seen in, for example, U.S. 2006/0151383 to AAF-McQuay Inc. and WO 2006/13271 to Fleetguard, Inc., that describe fluted media having folds or bends perpendicular to the flute direction to seal the ends of the flutes.

10 Referring to Figure 1, an exemplary type of media 1 useable as z-filter media is shown. Although the media 1 is representative of prior art media, many of the terms relied upon for describing the media 1 can also describe portions of the media according to the invention. The media 1 is formed from a fluted (in the example corrugated) sheet 3 and a facing sheet 4. In general, the fluted corrugated
15 sheet 3 is of a type generally characterized herein as having a regular, curved, wave pattern of flutes or corrugations 7. The term “wave pattern” in this context, is meant to refer to a flute or corrugated pattern of alternating troughs 7b and hills 7a. The term “regular” in this context is meant to refer to the fact that the pairs of troughs and hills (7b, 7a) alternate with generally the same repeating corrugation (or flute)
20 shape and size. (Also, typically in a regular configuration each trough 7b is substantially an inverse of each hill 7a.) The term “regular” is thus meant to indicate that the corrugation (or flute) pattern comprises troughs and ridges with each pair (comprising an adjacent trough and ridge) repeating, without substantial modification in size and shape of the corrugations along at least 70% of the length of
25 the flutes. The term “substantial” in this context, refers to a modification resulting from a change in the process or form used to create the corrugated or fluted sheet, as opposed to minor variations from the fact that the media sheet forming the fluted sheet 3 is flexible. With respect to the characterization of a repeating pattern, it is not meant that in any given filter construction, an equal number of ridges and
30 troughs is necessarily present. The media 1 could be terminated, for example, between a pair comprising a hill and a trough, or partially along a pair comprising a hill and a trough. (For example, in Fig. 1 the media 2 depicted in fragmentary has eight complete hills 7a and seven complete troughs 7b.) Also, the opposite flute

ends (ends of the troughs and hills) may vary from one another. Such variations in ends are disregarded in these definitions, unless specifically stated. That is, variations in the ends of flutes are intended to be covered by the above definitions.

In the context of fluted filtration media, and in particular the exemplary media 1, the troughs 7b and hills 7a can be characterized as peaks. That is, the highest point of the hills 7a can be characterized as peaks and the lowest points of the troughs 7b can be characterized as peaks. The combination of the fluted sheet 3 and the facing sheet 4 can be referred to as the single facer media 5. The peaks formed at the troughs 7b can be referred to as internal peaks because they face toward the facing sheet 3 of the single facer media 5. The peaks formed at the hills 7a can be characterized as external peaks because they face away from the facing sheet 3 forming the single facer media 5. For the single facer media 5, the fluted sheet 3 includes repeating internal peaks at 7b that face toward the facing sheet 4, and repeating external peaks at hills 7a that face away from the facing sheet 4.

The term “regular” when used to characterize a flute pattern is not intended to characterize media that can be considered “tapered.” In general, a taper refers to a reduction or an increase in the size of the flute along a length of the flute. In general, filtration media that is tapered can exhibit a first set of flutes that decrease in size from a first end of the media to a second end of the media, and a second set of flutes that increase in size from the first end of the media to the second end of the media. In general, a tapered pattern is not considered a regular pattern. It should be understood, however, that z-media can contain regions that are considered regular and regions that are considered non-regular along the flute length. For example, a first set of flutes may be considered regular along a distance of the flute length, such as, one quarter the distance to three quarters the distance, and then for the remaining amount of the flute length can be considered non-regular as a result of the presence of a taper. Another possible flute configuration is to have a tapered-regular-tapered arrangement where, for example, a flute tapers from a first face to a pre-selected location, the flute then can be considered regular until a second pre-determined location, and then the flute tapers to the second face. Another alternative arrangement can be provided as a regular-taper-regular arrangement, or as a regular-taper arrangement. Various alternative arrangements can be constructed as desired.

In the context of z-media, there are generally two types of “asymmetry.” One type of asymmetry is referred to as area asymmetry, and another type of asymmetry is referred to as volume asymmetry. In general, area asymmetry refers to an asymmetry in flute cross-sectional area, and can be exhibited by tapered
5 flutes. For example, area asymmetry exists if a fluted area at one location along the length of a flute is different from the fluted area at another location along the length of the flute. The fluted area refers to the area between the fluted sheet and the facing sheet. Because tapered flutes exhibit a decrease in size from a first location, e.g.,
10 end, to a second location (e.g., end) of the media pack or an increase in size from a first location (e.g., end) to a second location (e.g., end) of the media pack, there is an area asymmetry. This asymmetry (e.g., area asymmetry) is a type of asymmetry resulting from tapering and, as a result, media having this type of asymmetry can be referred to as non-regular. Another type of asymmetry can be referred to as volume
15 asymmetry, and will be explained in more detail. Volumetric asymmetry refers to a difference between a dirty side volume and a clean side volume within the filter media pack. Media exhibiting volume asymmetry can be characterized as regular if the wave pattern is regular, and can be characterized as non-regular if the wave pattern is non-regular.

Z-media can be provided where at least a portion of the flutes are
20 closed to the passage of unfiltered air by a technique other than providing a plug of adhesive or sealant. For example, the ends of flutes can be folded or crushed to provide a closure. One technique for providing a regular and consistent fold pattern for closing flutes can be referred to as darting. Darted flutes or darting generally refers to the closure of a flute wherein the closure occurs by indenting the flute and
25 folding the flute to create a regular fold pattern to collapse the flutes toward the facing sheet to provide a closure rather than by crushing. Darting generally implies a systematic approach to closing the ends of flutes as a result of folding portions of the flute so that the flute closures are generally consistent and controlled. For
30 example, U.S. Patent Publication No. US 2006 0163150 A1 discloses flutes having a darted configuration at the ends of the flutes. The darted configuration can provide advantages including, for example, a reduction in the amount of sealant needed to provide a seal, an increased security in the effectiveness of the seal, and a desirable flow pattern over the darted end of the flutes. Z-media can include flutes having

darted ends, and the entire disclosure of U.S. Patent Publication No. US 2006 0163150 A1 is incorporated herein by reference. It should be understood that the existence of darts at the ends of flutes does not render the media non-regular.

In the context of the characterization of a “curved” wave pattern, the term “curved” is meant to refer to a pattern that is not the result of a folded or creased shape provided to the media, but rather the apex of each hill 7a and the bottom of each trough 7b is formed along a radiused curve. Although alternatives are possible, a typical radius for such z-filter media would be at least 0.25 mm and typically would be not more than 3 mm. Media that is not curved, by the above definition, can also be useable. For example, it can be desirable to provide peaks having a radius that is sufficiently sharp so that it is not considered “curved.” The radius can be less than 0.25 mm, or less than 0.20 mm.. In order to reduce masking, it can be desirable to provide the peak with a knife edge. The ability to provide a knife edge at the peak can be limited by the equipment used to form the media, the media itself, and the conditions under which the media is subjected. For example, it is desirable to not cut or tear the media. Accordingly, using a knife edge to create the peak can be undesirable if the knife edge causes a cut or tear in the media. Furthermore, the media can be too light or too heavy to provide a sufficiently non-curved peak without cutting or tearing. Furthermore, the humidity of the air during processing can be enhanced to help create a tighter radius when forming the peak.

An additional characteristic of the particular regular, curved, wave pattern depicted in Fig. 1, for the corrugated sheet 3, is that at approximately a midpoint 30 between each trough 7b and each adjacent hill 7a, along most of the length of the flutes 7, is located a transition region where the curvature inverts. For example, viewing back side or face 3a, Fig. 1, trough 7b is a concave region, and hill 7a is a convex region. Of course when viewed toward front side or face 3b, trough 7b of side 3a forms a hill; and, hill 7a of face 3a, forms a trough. In some instances, region 30 can be a straight segment, instead of a point, with curvature inverting at ends of the segment 30.

A characteristic of the particular regular, curved, wave pattern corrugated sheet 3 shown in Fig. 1, is that the individual corrugations are generally straight. By “straight” in this context, it is meant that through at least 50% and preferably at least 70% (typically at least 80%) of the length between edges 8 and 9,

the hills 7a and troughs 7b do not change substantially in cross-section. The term “straight” in reference to corrugation pattern shown in Fig. 1, in part distinguishes the pattern from the tapered flutes of corrugated media described in Fig. 1 of WO 97/40918 and PCT Publication WO 03/47722, published June 12, 2003, incorporated herein by reference. The tapered flutes of Fig. 1 of WO 97/40918, for example, would be a curved wave pattern, but not a “regular” pattern, or a pattern of straight flutes, as the terms are used herein.

Referring to the present Fig. 1 and as referenced above, the media 2 has first and second opposite edges 8 and 9. For the example shown, when the media 2 is coiled and formed into a media pack, in general edge 9 will form an inlet end for the media pack and edge 8 an outlet end, although an opposite orientation is possible in some applications.

In the example shown, adjacent edge 8 is provided sealant, in this instance in the form of a sealant bead 10, sealing the fluted sheet 3 and the facing sheet 4 together. Bead 10 will sometimes be referred to as a “single facer” bead, since it is a bead between the corrugated sheet 3 and the facing sheet 4, which forms the single facer media 5. Sealant bead 10 seals closed individual flutes 11 adjacent edge 8, to passage of air therefrom.

In the example shown, at adjacent edge 9 is provided sealant, in this instance in the form of a sealant bead 14. Sealant bead 14 generally closes flutes to passage of unfiltered fluid therethrough, adjacent edge 9. Bead 14 would typically be applied as the media 2 is coiled about itself, with the corrugated sheet 3 directed to the inside. Thus, bead 14 will form a seal between a back side 17 of facing sheet 4, and side 18 of the fluted sheet 3. The bead 14 will sometimes be referred to as a “winding bead” since it is typically applied, as the strip 2 is coiled into a coiled media pack. If the media 2 is cut in strips and stacked, instead of coiled, bead 14 would be a “stacking bead.”

Referring to Fig. 1, once the media 1 is incorporated into a media pack, for example by coiling or stacking, it can be operated as follows. First, air in the direction of arrows 12, would enter open flutes 11 adjacent end 9. Due to the closure at end 8, by bead 10, the air would pass through the media shown by arrows 13. It could then exit the media pack, by passage through open ends 15a of the

flutes 15, adjacent end 8 of the media pack. Of course operation could be conducted with air flow in the opposite direction.

In more general terms, z-filter media comprises fluted filter media secured to facing filter media, and configured in a media pack of flutes extending
5 between first and second opposite flow faces. A sealant or seal arrangement is provided within the media pack, to ensure that air entering flutes at a first upstream face cannot exit the media pack from a downstream face, without filtering passage through the media. Alternately stated, a z-filter media is closed to passage of
10 unfiltered air therethrough, between the inlet face and the outlet flow face, typically by a sealant arrangement or other arrangement. An additional alternative characterization of this is that a first portion of the flutes are closed or sealed to prevent unfiltered air from flowing into the first portion of flutes, and a second portion of the flutes are closed or sealed to prevent unfiltered air from flowing out of the second portion of flutes so that air passing into one of the first face and the
15 second face of the media pack and out the other of the first face and the second face of the media pack passes through media to provide filtration of the air.

For the particular arrangement shown herein in Fig. 1, the parallel corrugations 7a, 7b are generally straight completely across the media, from edge 8 to edge 9. Straight flutes or corrugations can be deformed or folded at selected
20 locations, especially at ends. Modifications at flute ends for closure are generally disregarded in the above definitions of "regular," "curved" and "wave pattern."

In general, the filter media is a relatively flexible material, typically a non-woven fibrous material (of cellulose fibers, synthetic fibers or both) often including a resin therein, sometimes treated with additional materials. Thus, it can
25 be conformed or configured into the various fluted, for example corrugated, patterns, without unacceptable media damage. Also, it can be readily coiled or otherwise configured for use, again without unacceptable media damage. Of course, it must be of a nature such that it will maintain the desired fluted (for example corrugated) configuration, during use.

30 In the corrugation or fluting process, an inelastic deformation is caused to the media. This prevents the media from returning to its original shape. However, once the tension is released the flutes or corrugations will tend to spring back, recovering only a portion of the stretch and bending that has occurred. The

facing sheet is sometimes tacked to the fluted sheet, to inhibit this spring back in the fluted (or corrugated) sheet.

Also, typically, the media can contain a resin. During the corrugation process, the media can be heated to above the glass transition point of the resin.

5 When the resin then cools, it will help to maintain the fluted shapes.

The media of the fluted sheet 3, facing sheet 4 or both, can be provided with a fine fiber material on one or both sides thereof, for example in accord with U.S. Patent Nos. 6,955,775, 6,673,136, and 7,270,693, incorporated herein by reference. In general, fine fiber can be referred to as polymer fine fiber
10 (microfiber and nanofiber) and can be provided on the media to improve filtration performance. As a result of the presence of fine fiber on the media, it may be possible or desirable to provide media having a reduced weight or thickness while obtaining desired filtration properties. Accordingly, the presence of fine fiber on media can provide enhanced filtration properties, provide for the use of lighter
15 media, or both. Fiber characterized as fine fiber can have a diameter of about 0.001 micron to about 10 microns, about 0.005 micron to about 5 microns, or about 0.01 micron to about 0.5 micron. Nanofiber refers to a fiber having a diameter of less than 200 nanometer or 0.2 micron. Microfiber can refer to fiber having a diameter larger than 0.2 micron, but not larger than 10 microns. Exemplary materials that can
20 be used to form the fine fibers include polyvinylidene chloride, polyvinyl alcohol polymers and co-polymers comprising various nylons such as nylon 6, nylon 4, 6, nylon 6, 6, nylon 6, 10, and co-polymers thereof, polyvinyl chloride, PVDC, polystyrene, polyacrylonitrile, PMMA, PVDF, polyamides, and mixtures thereof.

Still referring to Fig. 1, at 20 tack beads are shown positioned
25 between the fluted sheet 3 and facing sheet 4, securing the two together. The tack beads 20 can be for example, discontinuous lines of adhesive. The tack beads can also be points in which the media sheets are welded together.

From the above, it will be apparent that the exemplary fluted sheet 3 depicted is typically not secured continuously to the facing sheet, along the peaks
30 where the two adjoin. Thus, air can flow between adjacent inlet flutes, and alternately between the adjacent outlet flutes, without passage through the media. However, unfiltered air which has entered a flute through the inlet flow face cannot

exit from a flute through the outlet flow face without passing through at least one sheet of media, with filtering.

Attention is now directed to Figure 2, in which a z-filter media construction 40 utilizing a fluted (in this instance regular, curved, wave pattern corrugated) sheet 43, and a non-corrugated flat, facing sheet 44, is depicted. The distance D1, between points 50 and 51, defines the extension of flat media 44 in region 52 underneath a given flute 53. The points 50 and 51 are provided as the center point of the internal peaks 46 and 48 of the fluted sheet 43. In addition, the point 45 can be characterized as the center point of the external peak 49 of the fluted sheet 43. The distance D1 defines the period length or interval of the media construction 40. The length D2 defines the arcuate media length for the flute 53, over the same distance D1, and is of course larger than D1 due to the shape of the flute 53. For a typical regular shaped media used in fluted filter applications according to the prior art, the ratio of the lengths D2 to D1 will be within a range of 1.2 - 2.0, inclusive. An exemplary arrangement common for air filters has a configuration in which D2 is about 1.25 x D1 to about 1.35 x D1. Such media has, for example, been used commercially in Donaldson Powercore™ Z-filter arrangements. Herein the ratio D2/D1 will sometimes be characterized as the flute/flat ratio or media draw for the media.

The flute height J is the distance from the flat, facing sheet 44 to the highest point of the fluted sheet 43. Alternatively stated, the flute height J is the difference in exterior elevation between alternating peaks 57 and 58 of the fluted sheet 43. The peak 57 can be referred to as the internal peak (the peak directed toward the facing sheet 44), and the peak 58 can be referred to as the external peak (the peak directed away from the facing sheet 44). Although the distances D1, D2, and J are applied to the specific fluted media arrangement shown in Figure 2, these distances can be applied to other configurations of fluted media where D1 refers to the period length of a flute or the distance of flat media underneath a given flute, D2 refers to the length of fluted media from lower peak to lower peak, and J refers to the flute height.

Another measurement can be referred to as the cord length (CL). The cord length refers to the straight line distance from the center point 50 of the peak 57 and the center point 45 of the peak 58. The thickness of the media and the decision

where to begin or end a particular distance measurement can affect the distance value if the media thickness affects the distance value. For example, the cord length (CL) can have a different value depending upon whether the distance is measured from the bottom of the internal peak to the bottom of the external peak or whether it is measured from the bottom of the internal peak to the top of the external peak. This difference in distance is an example of how the media thickness affects the distance measurement. In order to minimize the effect of the thickness of the media, the measurement for cord length is determined from a center point within the media. The relationship between the cord length CL and the media length D2 can be characterized as a media-cord percentage. The media-cord percentage can be determined according to the following formula:

$$\text{media-cord percentage} = \frac{\frac{1}{2} D_2 - CL}{CL} \times 100$$

In the corrugated cardboard industry, various standard flutes have been defined. These include, for example, the standard E flute, standard X flute, standard B flute, standard C flute, and standard A flute. Figure 3, attached, in combination with Table 1 below provides definitions of these flutes.

Donaldson Company, Inc., (DCI) the assignee of the present disclosure, has used variations of the standard A and standard B flutes, in a variety of z-filter arrangements. The DCI standard B flute can have a media-cord percentage of about 3.6%. The DCI standard A flute can have a media-cord percentage of about 6.3. Various flutes are also defined in Table 1 and Figure 3. Figure 2 shows a z-filter media construction 40 utilizing the standard B flute as the fluted sheet 43.

Table 1

(Flute definitions for Fig. 3)

5	DCI A Flute: Flute/flat = 1.52:1; The Radii (R) are as follows: R1000 = .0675 inch (1.715 mm); R1001 = .0581 inch (1.476 mm); R1002 = .0575 inch (1.461 mm); R1003 = .0681 inch (1.730 mm);
10	DCI B Flute: Flute/flat = 1.32:1; The Radii (R) are as follows: R1004 = .0600 inch (1.524 mm); R1005 = .0520 inch (1.321 mm); R1006 = .0500 inch (1.270 mm); R1007 = .0620 inch (1.575 mm);
15	Std. E Flute: Flute/flat = 1.24:1; The Radii (R) are as follows: R1008 = .0200 inch (.508 mm); R1009 = .0300 inch (.762 mm); R1010 = .0100 inch (.254 mm); R1011 = .0400 inch (1.016 mm);
20	Std. X Flute: Flute/flat = 1.29:1; The Radii (R) are as follows: R1012 = .0250 inch (.635 mm); R1013 = .0150 inch (.381 mm);
25	Std. B Flute: Flute/flat = 1.29:1; The Radii (R) are as follows: R1014 = .0410 inch (1.041 mm); R1015 = .0310 inch (.7874 mm); R1016 = .0310 inch (.7874 mm);
	Std. C Flute: Flute/flat = 1.46:1; The Radii (R) are as follows: R1017 = .0720 inch (1.829 mm); R1018 = .0620 inch (1.575 mm);
	Std. A Flute: Flute/flat = 1.53:1; The Radii (R) are as follows: R1019 = .0720 inch (1.829 mm); R1020 = .0620 inch (1.575 mm).

30 In general, standard flute configurations from the corrugated box industry have been used to define corrugation shapes or approximate corrugation shapes for corrugated media. Improved performance of filtration media can be achieved by providing a flute configuration or structure that enhances filtration. In the corrugated box board industry, the size of the flutes or the geometry of the

35 corrugation was selected to provide a structure suited for handling a load. The flute geometry in the corrugated box industry developed the standard A flute or B flute configuration. While such flute configurations can be desirable for handling a load, filtration performance can be enhanced by altering the flute geometry. Techniques for improving filtration performance include selecting geometries and configurations

40 that improve filtration performance in general, and that improve filtration performance under selected filtration conditions. Exemplary flute geometries and configurations that can be altered to improve filtration performance include flute masking, flute shape, flute width height ratio, and flute asymmetry. In view of the wide selection of flute geometries and configurations, the filter element can be

configured with desired filter element geometries and configurations in view of the various flute geometries and configurations to improve filtration performance.

Masking

5 In the context of z-media, masking refers to the area of proximity between the fluted sheet and the facing sheet where there is a lack of substantial pressure difference resulting in a lack of useful filtration media when the filtration media is in use. In general, masked media is not useful for significantly enhancing the filtration performance of filtration media. Accordingly, it is desirable to reduce
10 masking to thereby increase the amount of filtration media available for filtration and thereby increase the capacity of the filtration media, increase the throughput of the filtration media, decrease the pressure drop of the filtration media, or some or all of these.

 In the case of a fluted sheet arranged in a pattern with broad radii at
15 the peaks as shown in Figure 2, there exists a relatively large area of filtration media proximate the contact area of the fluted sheet and the facing sheets that is generally not available for filtration. Masking can be reduced by decreasing the radii of the peak or contact point between the fluted sheet and the facing sheet (e.g., providing sharper contact points). Masking generally takes into account the deflection of the
20 media when it is under pressure (e.g., during air filtration). A relatively large radius may result in more of the fluted media being deflected toward the facing sheet and thereby increasing masking. By providing a sharper peak or contact point (e.g., a smaller radius), masking can be reduced.

 Attempts have been made to reduce the radii of contact between the
25 fluted sheet and the facing sheet. For example, see U.S. Patent No. 6,953,124 to Winter et al. An example of reducing the radii is shown in Figure 4a where the fluted sheet 70 contacts the facing sheets 72 and 73 at relatively sharp peaks or contact points 74 and 75 in the fluted sheet 70. A curved wave pattern such as the curved wave pattern shown in Figure 1 generally provides a fluted sheet having a
30 radius at the peaks of at least 0.25 mm and typically not more than 3 mm. A relatively sharp peak or contact point can be characterized as a peak having a radius of less than 0.25 mm. Preferably, the relatively peak point can be provided having a radius of less than about 0.20 mm. In addition, masking can be reduced by

providing a peak having a radius of less than about 0.15 mm, and preferably less than about 0.10 mm. The peak can be provided having no radius or essentially a radius of about 0 mm. Exemplary techniques for providing fluted media exhibiting relatively sharp peaks or contact points includes coining, bending, folding, or
5 creasing the fluted media in a manner sufficient to provide a relatively sharp edge. It should be understood that the ability to provide a sharp edge depends on a number of factors including the composition of the media itself and the processing equipment used for providing coining, bending, folding, or creasing. In general, the ability to provide a relatively sharp contact point depends on the weight of the media
10 and whether the media contains fibers that resist tearing or cutting. In general, it is desirable to not cut the filtration media during coining, bending, folding, or creasing.

While it is desirable to reduce the radius of the peak (internal peak or external peak) to reduce masking, it is not necessary that all of the peaks have a reduced radius to decrease masking. Depending on the design of the media, it may
15 be sufficient to provide the external peaks with a reduced radius or to provide the internal peaks with a reduced radius, or to provide both the external peaks and the internal peaks with a reduced radius in order to decrease masking.

Increasing the Surface Area of Media

20 Filtration performance can be enhanced by increasing the amount of filtration media available for filtration. Reducing masking can be considered a technique for increasing the surface area of media available for filtration. Now referring to Figure 4a, the fluted sheet 70 can be considered to provide flutes having a cross-section resembling an equilateral triangle. Because the media is flexible, it is
25 expected that when the media is subjected to pressure such as during air filtration, the fluted sheet 70 may deflect. In addition, the fluted sheet 43 in Figure 2 can be considered to have flutes resembling a triangular shape. In general, fluted media where the flutes resemble equilateral triangles generally provides the least amount of media available for filtration compared with other flute designs where the period
30 length or interval D1 is increased or decreased, or the flute height J is increased or decreased, relative to the other.

Now referring to Figures 4b and 4c, Figure 4b refers to media where the fluted sheet 80 extends between the facing sheets 82 and 83. Figure 4c shows

media where the fluted sheet 90 extends between the facing sheets 92 and 93. The fluted sheet 80 is shown having a longer flute period than the fluted sheet 70 in Figure 4a. Accordingly, the fluted sheet 80 is provided having a relatively long period D1 relative to the flute height J compared with the media configuration shown in Figure 4a. Now referring to Figure 4c, the fluted sheet 90 is shown having a shorter flute period than the fluted sheet 70 in Figure 4a. The fluted sheet 90 is shown having a relatively large flute height J relative to the period D1 compared with the media configuration shown in Figure 4a.

The configuration of the fluted media can be characterized by the flute width height ratio. The flute width height ratio is the ratio of the flute period length D1 to the flute height J. The flute width height ratio can be expressed by the following formula:

$$\text{flute width height ratio} = \frac{D1}{J}$$

Measured distances such as flute period length D1 and the flute height J can be characterized as average values for the filtration media along the flute length within 20% of each flute end. Accordingly, the distances can be measured away from the ends of the flutes. It is typically the ends of the flutes that have a sealant or closure. The flute width height ratio calculated at a flute closure would not necessarily represent the flute width height ratio of the flute where the filtration is taking place. Accordingly, the measure of flute width height ratio can be provided as an average value over the flute length with the exception of the last 20% of the flute length near the ends of the flutes to remove the effects of flute closure when the flutes are closed near the ends. For "regular" media, it is expected that the flute period length D1 and the flute height J will be relatively constant along the flute length. By relatively constant, it is meant that the flute width height ratio can vary within about 10% over the length of the flute excluding the 20% length at each end when flute closure designs may effect the width height ratio. In addition, in the case of a non-regular media, such as, media having tapered flutes, the flute width height ratio can vary or remain about the same over the length of the flute. By adjusting the flute shape away from a theoretical equilateral triangle shape, the amount of media available for filtration can be increased. Accordingly, flutes having a flute width height ratio of at

least about 2.2, at least about 2.5, at least about 2.7, or at least about 3.0 can provide an increased surface area of media available for filtration. In addition, providing a flute design having a width height ratio of less than about 0.45, less than about 0.40, less than about 0.37, or less than about 0.33 can provide increased media area
5 available for filtration.

Flute Shape

The performance of the filtration media can be enhanced by modifying the flute shape. Providing a flute shape that increases the amount of filtration media available for filtration can increase performance. One technique for
10 increasing the amount of filtration media available for filtration is by creating a ridge between adjacent peaks. As discussed previously, adjacent peaks refers to an internal peak (facing toward the facing sheet) and an external peak (facing away from the facing sheet). Figures 5a-5c show representative exemplary flute shapes for enhancing filtration performance. The flute shape shown in Figure 5a can be
15 referred to as a “low contact” flute shape. The flute shapes shown in Figures 5b and 5c can be referred to as “zero strain” flute shapes. In general, the “low contact” name refers to the ability of the flute shape to enhance the amount of fluted media sheet between the facing media sheets while reducing the amount of contact (e.g., masking) between the fluted sheet and the facing sheet compared with standard A
20 and B fluted media. The “zero strain” name refers to the ability of the flute shape to provide a taper along a length of the flutes without inducing an undesired level of strain on the media. In general, an undesired level of strain (or elongation) in the media can refer to an amount of strain that causes a tear or rip in the media, or an amount of strain that requires the use of a special media that can withstand a higher
25 level of strain. In general, media that can withstand a strain of greater than about 12% can typically be considered a special media, and can be more expensive than media that is equipped to handle strain up to about 12%. The zero strain fluted sheet can additionally provide for reduced contact between the fluted sheet and the facing sheet.

30 Now referring to Figures 5a-5c, the media 110 includes fluted sheet 112 between facing sheets 111 and 113, the media 120 includes fluted sheet 122 between facing sheets 121 and 123, and the media 140 includes fluted sheet 142

between facing sheets 141 and 143. The combination of the fluted sheet 112 and the facing sheet 113 can be referred to as a single facer media 117, the combination of the fluted sheet 122 and the facing sheet 123 can be referred to as the single facer media 137, and the combination of fluted sheet 142 and facing sheet 143 can be referred to as the single facer media 147. When the single facer media 117, 137, or 147 is coiled or stacked, the facing sheet 111, 121, or 141 can be provided from another single facer media in the case of stacked media or from the same single facer media in the case of coiled media.

The media 110, 120, and 140 can be arranged to provide filter elements for cleaning a fluid such as air. The filter elements can be arranged as coiled elements or stacked elements. Coiled elements generally include a fluted media sheet and a facing media sheet that is wound to provide the coiled construction. The coil construction can be provided having a shape that is characterized as round, obround, or racetrack. A stacked construction generally includes alternating layers of media comprising fluted media sheet adhered to facing media sheet. The media 110, 120, and 140 shown in Figures 5a-5c are sectional views taken across the media to show the cross-sectional shape of the fluted sheet for the described shapes. It should be understood that the cross-sectional shape can be provided extending along a length of the flute. Furthermore, the flutes can be closed or sealed so that the media functions as z-media. The closure or seal can be provided, if desired, as an adhesive or sealant material.

In Figure 5a, the distance D1 is measured from the center point of the internal peak 114 to the center point of the external peak 116. The fluted media 110 is shown having two ridges 118 for each period length D1, or along the media length D2. The ridges 118 are provided extending along at least a portion of the length of the flute. In general, each ridge 118 can be characterized as a general area where a relatively flatter portion of the fluted media 118a joins a relatively steeper portion of the fluted media 118b. A ridge (e.g., a non-peak ridge) can be considered a line of intersection between differently sloped media portions. A ridge can be formed as a result of deformation of the media at that location. The media can be deformed at the ridge as a result of applying pressure to the media. Techniques for forming the ridge include coining, creasing, bending, and folding. Preferably, the ridge can be provided as a result of coining during a corrugation process where the corrugation

rolls apply pressure to the media to form the ridge. An exemplary technique for forming the fluted sheet and the single spacer media is described in U.S. Application Serial No. 61/025999 that was filed with the United States Patent and Trademark Office on February 4, 2008. The entire disclosure of U.S. Application Serial No. 5 61/025999 is incorporated herein by reference.

For the exemplary fluted sheet 112, the relatively flatter portion of the fluted media 118a can be seen in Figure 5a as the portion of the fluted media extending between the external peak 115 and the ridge 118. The average angle of the relatively flatter portion of the fluted media 118a from the external peak 115 to 10 the ridge 118 can be characterized as less than 45°, and can be provided as less than about 30° relative to the facing sheet 113. The relatively steeper portion of the fluted media 118b can be characterized as that portion of the media extending from the internal peak 116 to the ridge 118. In general, the angle of the relatively steeper portion of the fluted media 118b, as characterized as extending between the internal 15 peak 116 and the ridge 118 can be greater than 45° and can be greater than about 60° relative to the facing sheet 113. It is the difference in angle between the relatively flatter portion of the fluted media 118a and the relatively steeper portion of the fluted media 118b that can characterize the presence of the ridge 118. It should be understood that the angle of the relatively flatter portion of the fluted media 118a 20 and angle of the relatively steeper portion of the fluted media 118b can be determined as the average angle between the points that form the end points of the section of the media, and the angle is measured from the facing sheet.

The ridge 118 can be provided as a result of coining, creasing, bending, or folding along a length of the fluted sheet 112 during the formation of the 25 fluted media 12. It may be desirable, but it is not necessary, during the step of forming the fluted media 112 to take the steps to set the ridge 118. For example, the ridge 118 can be set by heat treatment or moisture treatment or a combination thereof. In addition, the ridge 118 can exist as a result of coining, creasing, bending, or folding to form the ridge without an additional step of setting the ridge. 30 Furthermore, the characterization of a ridge 118 is not to be confused with the fluted sheet external peaks 115 or 119 and the fluted sheet internal peaks 116 or 114. The characterization of a generally flatter portion 118a and a generally steeper portion 118b is intended as a way to characterize the presence of a ridge. In general, it is

expected that the flatter portion 118a and the steeper portion 118b will exhibit a curve. That is, it is expected that the flatter portion 118a and the steeper portion 118b will not be completely planar, particularly as fluids such as air flows through the media during filtration. Nevertheless, the angle of the media can be measured
5 from the ridge to the corresponding, adjacent peak to provide the average angle of that portion of the media.

The shape of the media depicted in Figure 5a can be referred to as a low contact shape. In general, the low contact shape refers to the relatively low area of contact between the fluted sheet 112 and the facing sheet 111. The presence of
10 the ridge 118 helps provide for reduced masking at the peaks 115 and 119. The ridge 118 exists as a result of deforming the fluted sheet 112 and, as a result, reduces the internal stress on the media at the peaks 115 and 119. Without the presence of the ridge 118, there would likely exist a level of internal tension in the fluted sheet 112 that would cause the fluted sheet 112 to create a greater radius at the peaks 115
15 and 119, and thereby increase masking. As a result, the presence of the ridge 118 helps increase the amount of media present between adjacent peaks (e.g., peaks 115 and 114) and helps decrease the radius of a peak (e.g., peak 115) as a result of relieving, to a certain extent, the tension within the fluted sheet 112 that would cause it to expand or flatten out at the peaks in the absence of the ridge.

20 The presence of a ridge 118 can be detected by visual observation. Figure 6 shows a photograph of an end view of a filter element wherein the fluted media can be characterized as having the low contact shape. While the presence of the low contact shape may not be particularly apparent from viewing the end of the fluted media, one can cut into the filter element and see the presence of a ridge
25 extending along a length of a flute. Furthermore, the presence of a ridge can be confirmed by a technique demonstrated by the photograph of Figure 7 where the filter element is loaded with dust, and the fluted sheet can be peeled away from the facing sheet to reveal a cake of dust having a ridge corresponding to the ridge on the fluted media. In general, the ridge on a cake of dust reflects a portion of the dust
30 surface having an average angle intersecting another portion of the dust surface having a different average angle. The intersection of the two portions of the dust surface cake forms a ridge. The dust that can be used to load the media to fill the

flutes to provide a cake of dust within the flutes can be characterized as ISO Fine test dust.

Now referring to Figure 5a, the fluted sheet 112 includes two ridges 118 over the distance D2 where the distance D2 refers to the length of the fluted sheet 112 from the center point of the peak 114 to the center point of the peak 116, and wherein the ridges are not the peaks 114, 115, 116, or 119. Although the peaks 114 and 116 can be referred to as internal peaks, and the peaks 115 and 119 can be referred to as the external peak, the peaks can additionally be characterized as the facing sheet peaks. In general, it is believed that the media will be arranged in different configurations such as wound or stacked and that the flutes will be arranged spacially so that the characterizations of internal and external can be disregarded in favor of the use of the characterization of the peak as a facing sheet peak. The use of the terms internal and external is convenient for describing the flute as it is shown in the figures. Although the fluted sheet 112 can be provided having two ridges 118 along each length D2, the fluted sheet 112 can be provided having a single ridge along each period length D2, if desired, and can be provided having a configuration where some of the periods exhibit at least one ridge, some periods exhibit two ridges, and some periods exhibit no ridge, or any combination thereof. The fluted sheet can be characterized as having a repeating pattern of flutes having at least one ridge in the repeating pattern. A repeating pattern of flutes means that the wave pattern exhibits a pattern that repeats over the direction transverse to the flute direction. The repeating pattern may be every adjacent peak, every other adjacent peak, every third adjacent peak, etc., or some variation that can be perceived as a pattern over the media.

The characterization of the presence of a ridge should be understood to mean that the ridge is present along a length of the flute. In general, the ridge can be provided along the flute for a length sufficient to provide the resulting media with the desired performance. While the ridge may extend the entire length of the flute, it is possible that the ridge will not extend the entire length of the flute as a result of, for example, influences at the ends of the flute. Exemplary influences include flute closure (e.g., darting) and the presence of plugs at the ends of flutes. Preferably, the ridge extends at least 20% of the flute length. By way of example, the ridge can extend at least 30% of the flute length, at least 40% of the flute length, at least 50%

of the flute length, at least 60% of the flute length, or at least 80% of the flute length. The ends of the flutes may be closed in some manner and that as a result of the closure, one may or may not be able to detect the presence of a ridge when viewing the media pack from a face. Accordingly, the characterization of the presence of a
5 ridge as extending along a length of the flute does not mean that the ridge must extend along the entire length of the flute. Furthermore, the ridge may not be detected at the ends of the flute. Attention is directed to the photograph of Figure 6 where it may be somewhat difficult to detect the presence of a ridge at the end of fluted media although the presence of the ridge can be detected within the media at a
10 distance from the end of the flute.

Now referring to Figure 5b, the fluted media 120 includes a fluted sheet 122 provided between facing sheets 121 and 123. The fluted sheet 122 includes at least two ridges 128 and 129 between the internal peak 124 and the external peak 125. Along the length D2, the media 122 includes four ridges 128 and
15 129. A single period length of media can include four ridges. It should be understood that the ridges 128 and 129 are not the peaks 124, 125, or 126 that can be referred to as the facing sheet peaks. The media 122 can be provided so that between adjacent peaks (e.g., peaks 125 and 126) there are two ridges 128 and 129. In addition, the fluted sheet 122 can be provided so that between other adjacent
20 peaks, there is one ridge or no ridge. There is no requirement that between each adjacent peak there are two ridges. There can be an absence of ridges between peaks if it is desirable to have the presence of ridges alternate or provided at predetermined intervals between adjacent peaks.

The ridge 128 can be characterized as the area where a relatively
25 flatter portion of the fluted media 128a joins a relatively steeper portion of the fluted media 128b. In general, the relatively flatter portion of the fluted media 128a can be characterized as having an angle of less than 45° and preferably less than about 30° wherein the angle is measured for the media between the ridge 128 and the ridge 129 and relative to the facing sheet 123. The relatively steeper portion of the fluted
30 media 128b can be characterized as having an angle of greater than 45° and preferably greater than about 60° wherein the angle is measured for the media from the peak 126 to the ridge 128 and relative to the facing sheet 123. The ridge 129 can be provided as a result of the intersection of the relatively flatter portion of the fluted

media 129a and the relatively steeper portion of the fluted media 129b. In general, the relatively flatter portion of the fluted media 129a corresponds to the angle of the portion of the media extending from the ridge 128 to the ridge 129 and relative to the facing sheet 123. In general, the relatively flatter portion of the fluted media

5 129a can be characterized as having a slope of less than 45° , and preferably less than about 30° . The relatively steeper portion of the fluted media 129b can be characterized as that portion of the fluted media extending between the ridge 129 and the peak 125 and can be characterized as having an angle measure for the media between the ridge 129 and the peak 125 and relative to the facing sheet 123. In

10 general, the relatively steeper portion of the fluted media 129b can be characterized as having an angle of greater than 45° and preferably greater than about 60° .

Now referring to Figure 5c, the fluted media 140 includes a fluted sheet 142 provided between facing sheets 141 and 143. The fluted sheet 142 includes at least two ridges 148 and 149 between the internal peak 144 and the

15 external peak 145. Along the length D2, the media 140 includes four ridges 148 and 149. A single period length of media can include four ridges. It should be understood that the ridges 148 and 149 are not the peaks 144 and 145. The media 140 can be provided so that between adjacent peaks (e.g., peaks 144 and 145) there are two ridges 148 and 149. In addition, the fluted sheet 140 can be provided so that

20 between other adjacent peaks, there is one ridge, two ridges, or no ridge. There is no requirement that between each adjacent peak there are two ridges. There can be an absence of ridges between peaks if it is desirable to have the presence of ridges alternate or provided at predetermined intervals between adjacent peaks. In general, a pattern of flutes can be provided where the pattern of flutes repeats and includes

25 the presence of ridges between adjacent peaks.

The ridges 148 and 149 can be characterized as the areas where a relatively flatter portion of the fluted sheet joins a relatively steeper portion of the fluted sheet. In the case of the ridge 148, a relatively flatter portion of the fluted sheet 148a joins a relatively steeper portion of the fluted sheet 148b. In the case of

30 the ridge 149, a relatively flatter portion of the fluted sheet 149a joins a relatively steeper portion of the fluted sheet 149b. The relatively steeper portion of the fluted media can be characterized as having an angle of greater than 45° and preferably greater than about 60° when measured for that portion of the media relative to the

facing sheet 143. The relatively flatter portion can be characterized as having a slope of less than 45° and preferably less than about 30° for that portion of the media relative to the facing sheet 143.

The fluted sheet 142 can be considered more advantageous to prepare relative to the fluted sheet 122 because the wrap angle of the fluted sheet 142 can be less than the wrap angle for the fluted sheet 122. In general, the wrap angle refers to the sum of angles resulting in media turns during the step of fluting. In the case of the fluted media 142, the media is turned less during fluting compared with the fluted media 122. As a result, by fluting to form the fluted sheet 142, the required

5
10

tensile strength of the media is lower compared with the fluted sheet 122.

The fluted sheets 112, 122, and 142 are shown as relatively symmetrical from peak to peak. That is, for the fluted sheets 112, 122, and 142, the flutes repeat having the same number of ridges between adjacent peaks. Adjacent peaks refer to the peaks next to each other along a length of fluted media. For example, for the fluted sheet 112, peaks 114 and 115 are considered adjacent peaks. A period of media, however, need not have the same number of ridges between adjacent peaks, and the media can be characterized as asymmetrical in this manner. That is, the media can be prepared having a ridge on one half of the period and not having a ridge on the other half of the period.

15
20

By providing a single ridge or multiple ridges between adjacent peaks of the fluted media, the distance D2 can be increased relative to prior art media such as standard A and B flutes. As a result of the presence of a ridge or a plurality of ridges, it is possible to provide filtration media having more media available for filtration compared with, for example, standard A flutes and B flutes. The previously described measurement of media-cord percentage can be used to characterize the amount of media provided between adjacent peaks. The length D2 is defined as the length of the fluted sheet 112, 122, and 142 for a period of the fluted sheet 112, 122, and 142. In the case of the fluted sheet 112, the distance D2 is the length of the fluted sheet from the lower peak 114 to the lower peak 116. This distance includes two ridges 118. In the case of the fluted sheet 122, the length D2 is the distance of the fluted sheet 122 from the lower peak 124 to the lower peak 126. This distance includes at least four ridges 128 and 129. The existence of increased filtration media between adjacent peaks as a result of providing one or

25
30

more ridge (or crease) between the adjacent peaks can be characterized by the media-cord percentage. As discussed previously, standard B flutes and standard A flutes have a media-cord percentage of about 3.6% and about 6.3%, respectively. In general, low contact flutes such as the flute design shown in Figure 5a can exhibit a
5 media-cord percentage of about 6.2% to about 8.2%. The flute designs shown in Figures 5b and 5c can provide a media-cord percentage of about 7.0% to about 16%.

The filtration media 120 and 140 in Figures 5b and 5c has an additional advantage of providing the ability to taper flutes along the length of the flute without creating a strain in the media. As a result of this, the flute shapes
10 referred to in Figures 5b and 5c can be referred to as the zero strain flute shapes. Now referring to Figures 8 and 9a, the fluted sheet 122 is shown in a tapered configuration. In Figure 9a, the fluted sheet 122 is shown tapering from the configuration 122a to the configuration 122d. As a result of the taper, the fluted media includes the configurations shown as 122b and 122c. As the fluted media
15 tapers from 122a to 122d, the ridges 128 and the ridges 129 approach the lower peaks 126 and move away from the upper peaks 125. Accordingly, as the fluted media 122 tapers from 122a to 122d, the cross sectional surface area between the fluted sheet 122 and the facing sheet 123 decreases. Corresponding with this decrease in cross sectional surface area, the corresponding flutes formed by the
20 fluted sheet 122 and a facing sheet contacting the upper peaks 125 experience an increase in cross sectional surface area. It is additionally observed that as the taper moves toward the end configurations shown at 122a and 122d, the ridges tend to merge together or become less distinguishable from each other. The configuration shown at 122a tends to look more like the low contact shape. In addition, it is seen
25 that as the fluted media tapers from 122d to 122a, the ridges 128 and the ridges 129 approach the upper peaks 125.

An advantage of using the filtration media 120 where the fluted sheet 122 contains ridges 128 and ridges 129 is the ability to taper the flutes without creating excessive strain, and the ability to use filtration media that need not exhibit
30 a strain greater than 12%. In general, strain can be characterized by the following equation:

$$\text{strain} = \frac{D2 \text{ max} - D2 \text{ min}}{D2 \text{ min}} \times 100$$

D2 min refers to the media distance where the media is relaxed or without strain, and D2 max refers to the media distance under strain at a point prior to tear.

Filtration media that can withstand a strain of up to about 12% is fairly commonly used in the filtration industry. Commonly used filtration media can be characterized as cellulosic based. In order to increase the strain that the media can withstand, synthetic fibers can be added to the media. As a result, it can be fairly expensive to use media that must withstand a strain greater than 12%. Accordingly, it is desirable to utilize a flute configuration that provides for tapering of the flute while minimizing the strain on the media, and avoiding the necessity of using expensive media that can tolerate higher strains than 12%.

Now referring to Figure 9b, the fluted sheet 142 of Figure 5c is shown in a tapered configuration extending from locations 142a to 142b, and then to 142c. As the flute tapers to a smaller cross-sectional area (the area between the fluted sheet 142 and the facing sheet 143), the ridges 148 and 149 move toward the peak 145. The reverse can also be said. That is, as the cross-sectional area in the flute increases, the ridges 148 and 149 move toward the peak 144.

The flute shapes exemplified in Figures 5a-5c can help provide for reducing the area of media that may become masked at the peaks compared with standard A and B fluted media. In addition, the shapes exemplified in Figures 5a-5c can help assist in increasing the amount of media available for filtration compared with standard A and B fluted media. In Figure 5a, viewing the fluted media 112 from the facing sheet 113, the ridges 118 can be seen to provide the flute with a concave appearance. From the perspective of facing sheet 111, the ridges 118 can be seen to provide the media extending between adjacent peaks with a convex appearance. Now referring to Figure 5b, the ridges 128 and 129 can be seen as providing both a concave and a convex appearance from either side of the fluted media 122 from peak to adjacent peak. It should be appreciated that the flutes are not actually concave or convex in view of the presence of the ridges. Accordingly, the ridges provide a transition or discontinuity in the curve. Another way of characterizing the presence of the ridge is by observing a discontinuity in the curve of the media wherein the discontinuity is not present in standard A flutes and B flutes. Furthermore, it should be appreciated that the flute shapes depicted in Figures 5a-5c and 9a-9b are somewhat exaggerated. That is, after forming the fluted

media, there will likely be a degree of spring or memory in the media that causes it to bow out or curve. Furthermore, the application of fluid (e.g., air) through the media may cause the media to deflect. As a result, the actual media prepared according to this description will not necessarily follow precisely along the drawings
5 presented in Figures 5a-5c and 9a-9b.

The single facer media configurations shown in Figures 5a-5c can be reversed, if desired. For example, the single facer media 117 includes the fluted sheet 112 and the facing sheet 113. If desired, the single facer media can be constructed so that it includes the fluted sheet 112 and the facing sheet 111.
10 Similarly, the single facer media shown in Figures 5b and 5c can be reversed, if desired. The characterization of the single facer media shown in Figures 5a-5c is provided for purposes of explaining the invention. One will understand that a single facer media can be prepared by combining the fluted sheet with a facing sheet in a manner essentially opposite of that depicted in Figures 5a-5c. That is, after the step
15 of fluting the fluted sheet, the fluted sheet can be combined with a facing sheet on either side of the fluted sheet.

Flute Volume Asymmetry

Flute volume asymmetry refers to a volumetric difference within a
20 filter element or filter cartridge between the upstream volume and the downstream volume. The upstream volume refers to the volume of the media that receives the unfiltered air, and the downstream volume refers to the volume of the media that receives the filtered air. Filter elements can additionally be characterized as having a dirty air side and a clean air side. In general, the dirty air side of filtration media
25 refers to the volume of media that receives the unfiltered air. The clean air side refers to the volume of media that receives the filtered air that has passed via filtering passage from the dirty air side. It can be desirable to provide a media having a dirty air side or upstream volume that is greater than the clean air side or downstream volume. It has been observed that particulates in the air are deposited
30 on the dirty air side and, as a result, the capacity of the filtration media can be determined by the volume of the dirty air side. By providing volume asymmetry, it is possible to increase the volume of the media available for receiving the dirty air side and thereby increase the capacity of the media pack.

Filtration media having the flute volume asymmetry exists when the difference between the upstream volume and the downstream volume is greater than 10%. Flute volume asymmetry can be expressed by the following formula:

$$\text{volume asymmetry} = \frac{\text{volume}_{\text{upstream}} - \text{volume}_{\text{downstream}}}{\text{volume}_{\text{downstream}}} \times 100$$

Preferably, media exhibiting volume asymmetry has volume asymmetry of greater than about 20%, and preferably about 40% to about 200%. In general, it may be desirable for the upstream volume to be greater than the downstream volume when it is desirable to maximize the life of the media. Alternatively, there may be situations where it is desirable to minimize the upstream volume relative to the downstream volume. For example, in the case of a safety element, it may be desirable to provide a safety element having a relatively low upstream volume so that the media fills and prevents flow relatively quickly as an indicator that failure has occurred in an upstream filter element.

The volume asymmetry can be calculated by measuring the cross-sectional surface area of flutes from a photograph showing a sectional view of the flutes. If the flutes form a regular pattern, this measurement will yield the flute volume asymmetry. If the flutes are not regular (e.g., tapered), then one can take several sections of the media and calculate the flute volume asymmetry using accepted interpolation or extrapolation techniques.

Flute design can be adjusted to provide a flute asymmetry that enhances filtration. In general, flute asymmetry refers to forming flutes having narrower peaks and widened arching troughs, or vice versa so that the upstream volume and downstream volume for the media are different. An example of a symmetric flute is provided in U.S. Patent Application Publication No. US 2003/0121845 to Wagner et al. The disclosure of U.S. Patent Application Publication No. US 2003/0121845 is incorporated herein by reference.

Now referring to Figures 10a and 10b, asymmetric flutes are shown by the filtration media 150 and 160. The filtration media 150 shows a fluted sheet 152 between facing sheets 154 and 155. The fluted sheet 152 is configured to provide a greater volume between the fluted sheet 152 and the facing sheet 154 than the volume defined by the fluted sheet 152 and the facing sheet 155. As a result, the

volume defined by the area between the fluted sheet 152 and the facing sheet 154 can be provided as the upstream volume or as the dirty side volume when it is desired to maximize the upstream volume or dirty side volume. The flute filtration media 160 shows a fluted sheet 162 between facing sheets 164 and 165. The fluted sheet is configured to provide a greater volume between the fluted sheet 162 and the facing sheet 165. The area between the fluted sheet 162 and the facing sheet 165 can be characterized, if desired, as the upstream volume or the dirty side volume.

Darted Flutes

Figures 11-18 illustrate a technique for closing an end of a flute. The technique can be referred to as darting and general techniques for darting flutes are described in U.S. Patent Publication No. US 2006/0163150 that published on July 27, 2006. The entire disclosure of U.S. Patent Publication No. US 2006/0163150 is incorporated herein by reference.

An exemplary darting technique that can be used to close flutes in filtration media according to the invention is shown in Figures 11-18. Although the darting technique provided in Figures 1-18 is shown in the context of prior art media, the darting technique can be applied to fluted media according to the present invention. For example, the fluted media shown in Figures 5a-5c can be darted according to the technique shown in Figures 11-18.

In general, darting can occur to provide closure after a facer bead 190 is applied for securing a fluted sheet 204 to a facing sheet 206. In general, and as described in U.S. Patent Publication No. US 2006/0163150, an indenting or darting wheel can be used to form the flutes 200 as shown in Figures 11-13, and a folder wheel can be used to form the flutes 200 as shown in Figures 14-18. As shown in Figures 11-13, the darting wheel deforms a portion 202 of the upper peak 204, by indenting or inverting it. By "inverting" and variants thereof, it is meant that the upper peak 204 is indented or turned inward in a direction toward the facing sheet 206. Figure 12 is a cross-sectional view along the mid-point of the inversion 210 created by the darting wheel. The inversion 210 is between a pair of peaks 212, 214 that are created as a result of the darting process. The peaks 212, 214 together form a flute double peak 216. The peaks 212, 214 in the flute double peak 216 have a height that is shorter than the height of the upper peak 204 before inversion. Figure

13 illustrates the cross-section of the flute 200 at a portion of the flute 200 that did not engage the darting wheel, and thus was not deformed. As can be seen in Figure 13, that portion of the flute 200 retains its original shape.

Attention is now directed to Figures 14-18. Figures 14-18 show sections of the darted section 198 after engagement with the folder wheel. Figure 5 18, in particular, shows an end view of the darted section 198, in cross-section. A fold arrangement 218 can be seen to form a darted flute 220 with four creases 221a, 221b, 221c, 221d. The fold arrangement 218 includes a flat first layer 222 that is secured to the facing sheet 64. A second layer 224 is shown pressed against the flat 10 first layer 222. The second layer 224 is preferably formed from folding opposite outer ends 226, 227 of the first layer 222.

Still referring to Figure 18, two of the folds or creases 221a, 221b will generally be referred to herein as “upper, inwardly directed” folds or creases. The term “upper” in this context is meant to indicate that the creases lie on an upper 15 portion of the entire fold 220, when the fold 220 is viewed in the orientation of Figure 11. The term “inwardly directed” is meant to refer to the fact that the fold line or crease line of each crease 221a, 221b, is directed toward the other.

In Figure 18, creases 221c, 221d, will generally be referred to herein as “lower, outwardly directed” creases. The term “lower” in this context refers to 20 the fact that the creases 221c, 221d are not located on the top as are creases 221a, 221b, in the orientation of Figure 14. The term “outwardly directed” is meant to indicate that the fold lines of the creases 221c, 221d are directed away from one another.

The terms “upper” and “lower” as used in this context are meant 25 specifically to refer to the fold 220, when viewed from the orientation of Figure 18. That is, they are not meant to be otherwise indicative of direction when the fold 120 is oriented in an actual product for use.

Based upon these characterizations and review of Figure 18, it can be seen that a preferred regular fold arrangement 218 according to Figure 18 in this 30 disclosure is one which includes at least two “upper, inwardly directed, creases.” These inwardly directed creases are unique and help provide an overall arrangement at which the folding does not cause a significant encroachment on adjacent flutes.

These two creases result in part from folding tips 212, 214, Figure 18, toward one another.

A third layer 228 can also be seen pressed against the second layer 224. The third layer 228 is formed by folding from opposite inner ends 230, 231 of the third layer 228. In certain preferred implementations, the facing sheet 206 will be secured to the fluted sheet 196 along the edge opposite from the fold arrangement 218.

Another way of viewing the fold arrangement 218 is in reference to the geometry of alternating peaks 204 and troughs 205 of the corrugated sheet 196. The first layer 222 includes the inverted peak 210. The second layer 224 corresponds to the double peak 216 that is folded toward, and in preferred arrangements, folded against the inverted peak 210. It should be noted that the inverted peak 210 and the double peak 216, corresponding to the second layer 224, is outside of the troughs 205 on opposite sides of the ridge 204. In the example shown, there is also the third layer 228, which extends from folded over ends 230, 231 of the double peak 216.

Figures 15-17 show the shape of the flute 200 at different sections. Figure 17 shows an undeformed section of the flute 200. The inversion 210 can be seen in Figures 15 and 16 extending along from where it engages the facing sheet 206 (Figure 18) to a point where it no longer exists (Figure 17). In Figures 15 and 16, the inversion 210 is spaced at different lengths from the facing sheet 206.

A process used to provide a dart according to Figures 1-18 can be referred to as “center indenting,” “center inverting,” “center darting” or “center deformation.” By the term “center” in this context, again, it is meant that the indentation or inversion occurred at an apex or center of the associated upper peak 80, engaged by the indenting or darting wheel. A deformation or indent will typically be considered herein to be a center indent, as long as it occurs within 3 mm of the center of a ridge. In the context of darting, the term “crease,” “fold,” or “fold line” are meant to indicate an edge formed by folding the media back on or over itself, with or without sealant or adhesive between portions of the media.

While the closure technique described in the context of Figures 11-18 can result in a flute closure as shown in Figure 18, it is possible that during darting, as a result of the flexibility of the media and the speed at which the media is moving,

the step of indenting may not occur precisely at the apex or peak of the corrugated sheet 196. As a result, folding of the tips 112 and 114 may not be as symmetrical as shown. In fact, one of the tips 212 and 214 may become somewhat flattened while the other tip is folded. Furthermore, in certain flute designs, it may be desirable to skip the indenting step. For example, the flute might have a height (J) that is sufficiently small so that the flute can be pressed closed to provide a repeating fold pattern without requiring a step of indenting the flute tip.

Plug Length and Flute Height

10 Z-media is sometimes characterized as having flutes extending from an inlet face to an outlet face and wherein a first portion of the flutes can be characterized as inlet flutes and a second portion of the flutes can be characterized as outlet flutes. The inlet flutes can be provided with a plug or seal near the outlet face, and the outlet flutes can be provided with a plug or seal near or adjacent the inlet face. Of course, alternatives of this arrangement are available. For example, the seals or plugs need not be provided at or adjacent the inlet face or outlet face. The seals or plugs can be provided away from the inlet face or the outlet face, as desired. In the case of hot melt adhesive being used as a seal or plug, it is often found that the plug has a length of at least about 12 mm. The applicants have found that by reducing the plug length, it is possible to increase desirable characteristics of the filtration media including capacity, lower initial pressure drop, reduced amount of media, or combinations thereof. It can be desirable to provide a plug length that is less than about 10 mm, preferably less than about 8 mm, and even more preferably less than about 6 mm.

25 The flute height (J) can be adjusted as desired depending upon filtration conditions. In the case where a filter element utilizing the media according to the present invention is used as a substitute for a conventional filter element that utilizes, for example, a standard B flute, the height J can be about 0.075 inch to about 0.150 inch. In the case where a filter element utilizing the media according to the present invention is used as a substitute for a conventional filter element that utilizes, for example, a standard A flute, the height J can be about 0.15 inch to about 0.25 inch.

Filter Elements

Now referring to Figures 19-28, filter elements are described that include an air filtration media pack. The air filtration media pack can include the single facer media as described herein.

5 The air filtration media pack can be provided as part of a filter element containing a radial seal as described in, for example, U.S. Patent No. 6,350,291, U.S. Patent Application No. US 2005/0166561, and International Publication No. WO 2007/056589, the disclosures of which are incorporated herein by reference. For example, referring to Figure 19, the filter element 300 includes air
10 filtration media pack 301 that can be provided as a wound media pack 302 of single facer media, and can include a first face 304 and a second face 306. A frame 308 can be provided on a first end of the media pack 310, and can extend beyond the first face 304. Furthermore, the frame 308 can include a step or reduction in circumference 312 and a support 314 that extends beyond the first face 304. A seal
15 member 316 can be provided on the support 314. When the filter element 301 is introduced within the housing 320, the seal member 316 engages the housing sealing surface 322 to provide a seal so that unfiltered air does not bypass the air filtration media pack 300. The seal member 316 can be characterized as a radial seal because the seal member 316 includes a seal surface 317 that engages the housing sealing
20 surface 322 in a radial direction to provide sealing. In addition, the frame 308 can include a media pack cross brace or support structure 324 that helps support the frame 308 and helps reduce telescoping of the air filtration media pack 300. An access cover 324 can be provided for enclosing the filter element 300 within the housing 320.

25 The air filtration media pack can be provided as part of a filter element having a variation on the radial seal configuration. As shown in Figure 20, the seal 330 can be relied upon for holding the frame 332 to the media pack 334. As shown in Figure 19, the frame 308 can be adhesively attached to the media pack
30 301. As shown in Figure 20, the frame 332 can be provided adjacent to the first face 336 and the seal 330 can be provided so that it holds the support 332 onto the media pack 334 without the use of additional adhesive. The seal 330 can be characterized as an overmold seal in that it expands along both sides of the seal support 338 and onto the outer surface of the media pack 334 at the first end 340.

The air filtration media pack can be provided as part of a filter element according to U.S. Patent No. 6,235,195, the entire disclosure of which is incorporated herein by reference. Now referring to Figure 21, the filter element 350 includes a wound media pack 352 having an oblong or racetrack shape, and an axial pinch seal 354 attached to the end circumscribing the exterior of the media pack. 5 The axial pinch seal 354 is shown provided between the first face 356 and the second face 358 of the media pack. The axial pinch seal 354 includes a base portion 360 and a flange portion 362. In general, the flange portion 362 is intended to be pinched between two surfaces to create a seal. One of the surfaces can be a surface 10 of the housing that contains the filter element 350. In addition, the other structure that pinches the flange 362 can be an access cover or another structure provided within the housing that helps maintain the seal so that unfiltered air passes through the media pack without bypassing the media pack. The filter element 350 can include a handle 364 extending axially from the first face 356. If desired, the handle 15 can be provided extending axially from the second face 358. The handle 364 allows one to pull or remove the filter element 350 from the housing.

Now referring to Figures 22-24, a filter element is shown at reference number 400. The filter element 400 includes a wound media pack 402, a handle arrangement 404, and a seal arrangement 406. Details of this filter element 20 construction can be found in U.S. Patent No. 6,348,084, the entire disclosure of which is incorporated herein by reference. The previously described single facer media can be used to prepare the filter element 400.

The handle arrangement 404 includes a center board 408, handles 410, and a hook construction 412. The single facer media can be wound around the center board 408 so that the handles 410 extend axially from a first face 414 of the media pack 402. The hook arrangement 412 can extend from the second face 416 of the media pack 402. The handles 410 allow an operator to remove the filter element 400 from a housing. The hook construction 412 provides for attachment to a cross brace or support structure 420. The hook construction 412 includes hook members 30 422 and 424 that engage the cross brace or support structure 420. The cross brace or support structure 420 can be provided as part of a seal support structure 430 that extends from the second face 416 and includes a seal support member 432. A seal 434 can be provided on the seal support member 432 to provide a seal between the

filter element 400 and a housing. The seal 434 can be characterized as a radial seal when the seal is intended to provide sealing as a result of contact of a radially facing seal surface 436 and a housing seal surface.

The air filtration media pack can be provided as part of a gas turbine system as shown in U.S. Patent No. 6,348,085, the entire disclosure of which is incorporated herein by reference. An exemplary gas turbine filtration element is shown at reference number 450 in Figure 25. The filter element 450 can include a primary filter element 452 and a secondary filter element 454. The secondary filter element 454 can be referred to as a safety filter element. The main filter element 452 can be provided as an air filtration media pack as previously described in this application. The air filtration media pack can be provided as a result of winding a single facer media or as a result of stacking a single facer media. The primary filter element 452 and the secondary filter element 454 can be secured within a sleeve member 460. The sleeve member 460 can include a flange 462 that includes a seal 464. When installed, the element 450 can be provided so that the flange 462 and seal 464 are provided adjacent a support 466 and held in place by a clamp 200 so that the seal 464 provides a sufficient seal so that unfiltered air does not bypass the filter element 450.

Another filter element that can utilize the air filtration media pack is described in U.S. Patent No. 6,610,126, the entire disclosure of which is incorporated herein by reference. Now referring to Figure 26, the filter element 500 includes an air filtration media pack 502, a radial seal arrangement 504, and a dust seal arrangement 506. The filter element 500 can be provided within an air cleaner housing 510 and can include, downstream of the filter element 500, a safety or secondary filter element 512. Furthermore, an access cover 514 can be provided for enclosing the housing 510. The housing 510 and the access cover 514 can pinch the dust seal 506 so that the dust seal 506 can be characterized as a pinch seal.

The air filtration media pack can be provided as a stacked media pack arrangement according to International Publication No. WO 2006/076479 and International Publication No. WO 2006/076456, the disclosures of which are incorporated herein by reference. Now referring to Figure 27, a filter element is shown at reference number 600 that includes a stacked, blocked, media pack 602. The blocked stacked media pack 602 can be characterized as a rectangular or right

(normal) parallelogram media pack. To seal the opposite ends of the media pack 602 are positioned side panels 604 and 606. The side panels 604 and 606 seal the lead end and tail end of each stacked, single facer media. The media pack 602 has opposite flow faces 610 and 612. It is pointed out that no flow path between faces 5 610 and 612 is provided that does not also require the air to pass through media of the media pack 602 and thus to be filtered. A peripheral, perimeter, housing seal ring 614 is positioned in the air filter element 600. The particular seal ring 614 depicted is an axial pinch seal ring. If desired, a protective sheet or panel can be provided over the media pack surfaces 620 and 622.

10 The air filtration media pack can be provided as a stacked media pack arrangement according to International Publication No. WO 2007/133635, the entire disclosure of which is incorporated herein by reference. Now referring to Figure 28, a filter element is shown at reference number 650. The filter element 650 includes a stacked z-filter media arrangement 652 having a first, in this instance, inlet face 654, 15 and an opposite second, in this instance, outlet face 656. In addition, the filter element 650 includes an upper side 660, a lower side 662, and opposite side end 664 and 666. The stacked z-filter media arrangement 652 generally comprises one or more stacks of strips of single facer media where each strip comprises a fluted sheet secured to a facing sheet. The strips are organized with flutes extending between the 20 inlet face 654 and the outlet face 656. The filter element 650 depicted comprises a stacked z-filter media pack arrangement comprising two stacked media pack sections 670 and 672. A seal member 680 can be molded to the media pack.

 It should be appreciated that, in view of exemplary Figures 19-27, that the air filtration media pack can be provided in various configurations to form 25 filter elements that can then be used in various housing arrangements to provide enhanced performance.

Examples

 Filter elements having media containing various flute designs were 30 compared using filter media performance modeling software. The filter elements were not constructed and tested for this example. Instead, the dimensions of the filter elements and the filter element components, the properties and characteristics of the filter elements and the filter element components, the conditions of use, and

the characteristics of the air being filtered were inputted into a computer program that models filter media performance. The filter media performance modeling software was validated based upon tests run on actual Donaldson Company filter media. The results of the computer software modeling are expected to have an error
5 within about 10%. For the purpose of evaluating different filter media design alternatives, it is believed that an error value of within about 10% is sufficiently low that the modeling software can be used to evaluate various design options.

Tables 2-5 include a characterization of the filter element and the computer generated results. The tables identify the size of the element evaluated
10 using the filter media performance modeling software. The element size refers to the overall size of the element. In Tables 2, 4, and 5, the elements are stacked panel z-media elements having a size of 8 inches x 12 inches x 5 inches. In Table 3, the element is a coiled z-media element having a size of 17 inch diameter x 12 inch depth.

Table 2

Element	Element Size (inches)	Comments	Flute Type and Size	Flute Height (J) (inches)	Plug Length (mm)	Media Thickness (inches)	Initial Pressure Drop (inches water gauge)	% of Initial Pressure Drop of Base Filter	SAE Fine Loading to 12 Inches H ₂ O Pressure Drop	% of Loading of Base Filter	Element Volume (ft ³)	% Volume of Base Filter	Media Required (ft ²)	% Area of Base Filter	Flow Rate (cfm)
1	8 x 12 x 5	Baseline	Standard B	0.103	12.7	0.0109	1.88	100%	606	100%	0.2777	100%	65.7	100%	636
2	8 x 12 x 5	Element 1 plus darting	Standard B	0.103	12.7	0.0109	1.65	88%	618	102%	0.2777	100%	65.7	100%	636
3	8 x 12 x 5	Element 2 plus reducing plug length	Standard B	0.103	5	0.0109	1.65	88%	837	138%	0.2777	100%	65.7	100%	636
4	8 x 12 x 5	Element 3 plus low contact shape	Low contact	0.103	5	0.0109	1.83	97%	1256	207%	0.2777	100%	67.4	103%	636
5	8 x 12 x 5	Element 4 plus low contact shape	Low contact	0.103	5	0.0109	1.97	105%	1228	203%	0.2777	100%	68.1	104%	636
6	8 x 12 x 5	Element 5 plus media thickness	Low contact	0.103	5	0.009	1.73	92%	1328	219%	0.2777	100%	69.6	106%	636

Table 3

Element	Element Size (inches)	Comments	Flute Type and Size	Flute Height (J) (inches)	Plug Length (mm)	Media Thickness (inches)	Initial Pressure Drop (inches water gauge)	% of Initial Pressure Drop of Base Filter	SAE Fine Loading to 12 Inches H ₂ O Pressure Drop	% of Loading of Base Filter	Element Volume (ft ³)	% Volume of Base Filter	Media Required (ft ³)	% Area of Base Filter	Flow Rate (cfm)
7	17 diameter x 12 deep	Baseline with A	Standard A	0.196	15	0.0109	1.53	66%	5285	64%	1.57	100%	229	61%	1600
8	17 diameter x 12 deep	Baseline with B	Standard B	0.103	15	0.0109	2.32	100%	8279	100%	1.57	100%	374	100%	1600
9	17 diameter x 12 deep	Element 8 plus darting	Standard B	0.103	15	0.0109	2.06	89%	8385	101%	1.57	100%	374	100%	1600
10	17 diameter x 12 deep	Element 9 plus reducing plugs	Standard B	0.103	5	0.0109	2.37	102%	9265	112%	1.57	100%	374	100%	1600
11	17 diameter x 12 deep	Element 10 plus low contact	Low contact	0.08	5	0.0109	3.14	135%	11585	140%	1.57	100%	446	119%	1600
12	17 diameter x 12 deep	Element 11 plus thinner media	Low contact	0.08	5	0.009	2.77	119%	12688	153%	1.57	100%	458	122%	1600

Table 4

Element	Element Size (inches)	Comments	Flute Type and Size	Flute Height (J) (inches)	Media Thickness (inches)	Plug Size (mm)	Initial Pressure Drop (inches water gauge)	% of Initial Pressure Drop of Base Filter	SAE Fine Loading to 12 Inches H ₂ O Pressure Drop	% of Loading of Base Filter	Element Volume (ft ³)	% Volume of Base Filter	Media Required (ft ²)	% Area of Base Filter	Flow Rate (cfm)
13	8 x 12 x 5	Baseline	Standard B	0.1039	0.0109	12.7	1.92	100%	1040	100%	0.2778	100%	65.69	100%	400
14	8 x 12 x 5	Element 13 plus darting	Standard B	0.1039	0.0109	12.7	1.832	90%	1046	101%	0.2778	100%	65.69	100%	400
15	8 x 12 x 5	Element 14 plus shorter plugs	Standard B	0.1039	0.0109	5	1.835	91%	1345	129%	0.2778	100%	65.69	100%	400
16	8 x 12 x 5	Element 15 plus low contact	Low contact	0.1039	0.0109	5	1.045	114%	1974	190%	0.2778	100%	65.69	100%	400
17	8 x 12 x 5	Element 16 plus thinner media	Low contact	0.1039	0.009	5	1.918	100%	2112	203%	0.2778	100%	69.58	106%	400

Table 5

Element	Element Size (inches)	Comments	Flute Type and Size	Flute Height (I) (inches)	Media Thickness (inches)	Plug Size (mm)	Initial Pressure Drop (inches water gauge)	% of Initial Pressure Drop of Base Filter	SAE Fine Loading to 12 Inches H ₂ O Pressure Drop	% of Loading of Base Filter	Element Volume (ft ³)	% Volume of Base Filter	Media Required (ft ²)	% Area of Base Filter	Flow Rate (cfm)
23	8 x 12 x 5	Baseline	Standard B	0.1039	0.0109	12.7	3.164	100%	368	100%	0.2778	100%	65.69	100%	872
24	8 x 12 x 5	Element 23 plus darting	Standard B	0.1039	0.0109	12.7	2.731	86%	384	104%	0.2778	100%	65.69	100%	872
25	8 x 12 x 5	Element 25 plus shorter plugs	Standard B	0.1039	0.0109	5	2.732	86%	536	146%	0.2778	100%	65.69	100%	872
26	8 x 12 x 5	Element 25 plus low contact	Low contact	0.1039	0.0109	5	3.12	99%	756	205%	0.2778	100%	65.69	100%	872
27	8 x 12 x 5	Element 26 plus thinner media	Low contact	0.1039	0.009	5	2.739	87%	834	227%	0.2778	100%	65.69	100%	872

The above specification, examples and data provide a complete description of the manufacture and use of the filtration media and filter element of the invention. Since many embodiments of the invention can be made without departing from the spirit and scope of the invention, the invention resides in the

5 claims hereinafter appended.

WE CLAIM:

1. An air filtration media pack comprising:
 - (a) a plurality of layers of single facer media wherein the layer of single facer media comprising a fluted sheet, a facing sheet, and a plurality of flutes extending between the fluted sheet and the facing sheet and having a flute length extending from a first face of the filtration media pack to a second face of the filtration media pack;
 - (b) a first portion of the plurality of flutes being closed to unfiltered air flowing into the first portion of the plurality of flutes, and a second portion of the plurality of flutes being closed to unfiltered air flowing out of the second portion of the plurality of flutes so that air passing into one of the first face or the second face of the media pack and out the other of the first face or the second face of the media pack passes through media to provide filtration of the air; and
 - (c) wherein the fluted sheet comprises:
 - (i) repeating internal peaks facing toward the facing sheet and repeating external peaks facing away from the facing sheet; and
 - (ii) a repeating pattern of flutes comprising at least one ridge extending along at least a portion of the flute length between adjacent peaks.
2. An air filtration media pack according to claim 1, wherein the ridge comprises a juncture of a relatively steeper portion of the fluted media and a relatively flatter portion of the fluted media.
3. An air filtration media pack according to claim 2, wherein the relatively flatter portion of the fluted media has an average angle, based on the facing sheet, of less than 45°.
4. An air filtration media pack according to claim 2, wherein the relatively flatter portion of the fluted media has an average angle, based on the facing sheet, of less than about 30°.

5. An air filtration media pack according to claim 2, wherein the relatively steeper portion of the fluted media has an average angle, based on the facing sheet, of greater than 45°.
6. An air filtration media pack according to claim 2, wherein the relatively steeper portion of the fluted media has an average angle, based on the facing sheet, of greater than about 60°.
7. An air filtration media pack according to claim 1, wherein the ridge extends at least 20% of the flute length between adjacent peaks.
8. An air filtration media pack according to claim 1, wherein the ridge extends at least 50% of the flute length between adjacent peaks.
9. An air filtration media pack according to claim 1, wherein the fluted sheet comprises a repeating pattern of flutes comprising at least two ridges extending along at least 20% of the flute length between adjacent peaks.
10. An air filtration media pack according to claim 1, wherein the first portion of the plurality of flutes are closed by a sealant bead and the second portion of the plurality of flutes are closed by a sealant bead.
11. An air filtration media pack according to claim 1, comprising tapered flutes.
12. An air filtration media pack according to claim 1, wherein the media pack has an asymmetric volume arrangement so that a volume on one side of the media pack is greater than a volume on another side of the media pack by at least 10%.
13. An air filtration media pack according to claim 1, wherein the media pack has an asymmetric volume arrangement so that a volume on one side of the

media pack is greater than a volume on another side of the media pack by about 40% to about 200%.

14. An air filtration media pack according to claim 1, wherein the single facer media is provided in a coiled arrangement.

15. An air filtration media pack according to claim 1, wherein a plurality of the single facer media are provided in a stacked arrangement.

16. An air filtration media pack according to claim 1, wherein the internal peaks or the external peaks have a radius of less than 0.25 mm.

17. An air filtration media pack according to claim 1, wherein the internal peaks or the external peaks have a radius of less than 0.20 mm.

18. An air filtration media pack according to claim 1, wherein the fluted sheet provides a media-cord percentage of greater than about 6.2%.

19. An air filtration media pack according to claim 1, wherein the fluted sheet provides a media-cord percentage of about 6.2% to 8.2%.

20. An air filtration media pack according to claim 1, wherein the fluted sheet provides a media-cord percentage of about 7.0% to 16%.

21. A filter element comprising an air filtration media pack according to claim 1, and a seal member extending around a periphery of the media pack.

22. A filter element according to claim 21, wherein the seal member comprises a seal surface constructed to engage an air cleaner housing surface in a radially extending direction.

23. A filter element according to claim 21, wherein the seal member comprises a seal surface constructed to engage an air cleaner housing surface in a axially extending direction.

24. An air filtration media pack comprising:

(a) a plurality of layers of single facer media wherein the layer of single facer media comprising a fluted sheet, a facing sheet, and a plurality of flutes extending between the fluted sheet and the facing sheet and having a flute length extending from a first face of the filtration media pack to a second face of the filtration media pack;

(b) a first portion of the plurality of flutes being closed to unfiltered air flowing into the first portion of the plurality of flutes, and a second portion of the plurality of flutes being closed to unfiltered air flowing out of the second portion of the plurality of flutes so that air passing into one of the first face or the second face of the media pack and out the other of the first face or the second face of the media pack passes through media to provide filtration of the air; and

(c) wherein at least a portion of the plurality of flutes exhibit a flute width height ratio of greater than about 2.2 or less than about 0.45, and a media-cord percentage of at least about 6.2%.

25. An air filtration media pack according to claim 24, wherein the fluted sheet comprises repeating internal peaks facing toward the facing sheet and repeating external peaks facing away from the facing sheet, and a repeating pattern of flutes comprising at least one ridge extending along at least 20% of the flute length between an internal peak and an adjacent external peak.

26. An air filtration media pack according to claim 25, wherein the at least one ridge extends along at least 50% of the flute length.

27. An air filtration media pack according to claim 25, comprising a repeating pattern of flutes comprising at least two ridges extending along at least 20% of the flute length between an internal peak and an adjacent external peak.

28. An air filtration media pack according to claim 24, wherein the first portion of the plurality of flutes are closed by a sealant bead and the second portion of the plurality of flutes are closed by a sealant bead.
29. An air filtration media pack according to claim 24, wherein at least a portion of the plurality of flutes are tapered.
30. An air filtration media pack according to claim 24, wherein the media pack has a volume asymmetry volume so that a volume on one side of the media pack is greater than a volume on another side of the media pack by at least 10%.
31. An air filtration media pack according to claim 24, wherein the media pack has a volume asymmetry so that a volume on one side of the media pack is greater than a volume on another side of the media pack by about 40% to about 200%.
32. An air filtration media pack according to claim 24, wherein the single facer media is provided in a coiled arrangement.
33. An air filtration media pack according to claim 24, wherein a plurality of the single facer media are provided in a stacked arrangement.
34. An air filtration media pack according to claim 24, wherein the internal peaks or the external peaks have a radius of less than 0.25 mm.
35. An air filtration media pack according to claim 24, wherein the internal peaks or the external peaks have a radius of less than 0.20 mm.
36. An air filtration media pack according to claim 24, wherein the at least a portion of flutes exhibit a media-cord percentage of about 6.2% to 8.2%.
37. An air filtration media pack according to claim 24, wherein the fluted sheet provides a media-cord percentage of about 7.0% to 16%.

38. An air filtration media pack according to claim 24, wherein the at least a portion of flutes exhibits a flute with height ratio of greater than about 2.5.

39. An air filtration media pack according to claim 24, wherein the at least a portion of flutes exhibits a flute with height ratio of less than about 0.40.

40. A filter element comprising an air filtration media pack according to claim 24, and a seal member extending around a periphery of the media pack.

41. A filter element according to claim 40, wherein the seal member comprises a seal surface constructed to engage an air cleaner housing surface in a radially extending direction.

42. A filter element according to claim 40, wherein the seal member comprises a seal surface constructed to engage an air cleaner housing surface in a axially extending direction.

43. An air filtration media pack comprising:

(a) a plurality of layers of single facer media wherein the layer of single facer media comprising a fluted sheet, a facing sheet, and a plurality of flutes extending between the fluted sheet and the facing sheet and having a flute length extending from a first face of the filtration media pack to a second face of the filtration media pack;

(b) a first portion of the plurality of flutes being closed to unfiltered air flowing into the first portion of the plurality of flutes, and a second portion of the plurality of flutes being closed to unfiltered air flowing out of the second portion of the plurality of flutes so that air passing into one of the first face or the second face of the media pack and out the other of the first face or the second face of the media pack passes through media to provide filtration of the air; and

(c) wherein at least a portion of the plurality of flutes exhibit a flute width height ratio of greater than 2.2 or less than 0.45, and a volume

asymmetry so that a volume on one side of the media pack is greater than a volume on another side of the media pack by at least 10%.

44. An air filtration media pack according to claim 43, wherein the volume asymmetry is about 40% to about 200%.

45. An air filtration media pack according to claim 43, wherein the fluted sheet comprises repeating internal peaks facing toward the facing sheet and repeating external peaks facing away from the facing sheet, and a repeating pattern of flutes comprising at least one ridge extending along at least 20% of the flute length between an internal peak and an adjacent external peak.

46. An air filtration media pack according to claim 45, comprising a repeating pattern of flutes comprising at least two ridges extending along at least 20% of the flute length between an internal peak and an adjacent external peak.

47. An air filtration media pack according to claim 43, wherein the single facer media is provided in a coiled arrangement.

48. An air filtration media pack according to claim 43, wherein a plurality of the single facer media are provided in a stacked arrangement.

49. A filter element comprising an air filtration media pack according to claim 43, and a seal member extending around a periphery of the media pack.

50. A filter element according to claim 49, wherein the seal member comprises a seal surface constructed to engage an air cleaner housing surface in a radially extending direction.

51. A filter element according to claim 49, wherein the seal member comprises a seal surface constructed to engage an air cleaner housing surface in a axially extending direction.

52. A fluted media sheet comprising a repeating pattern of internal peaks and external peaks, wherein the repeating pattern comprises at least one ridge extending along at least 50% of a flute length between an internal peak and an adjacent external peak, wherein the media comprises a cellulose based media for fluid filtration.

53. A fluted media sheet according to claim 52, wherein the repeating pattern comprises at least two ridges extending along at least 50% of the flute length between an internal peak and an adjacent external peak.

54. A method for filtering air through the air filtration media pack according to claim 1, the method comprising causing air to flow into one of the first face of the filtration media pack or the second face of the filtration media pack, and out the other of the first face of the filtration media pack or the second face of the filtration media pack, wherein the air passes through media to provide filtration of the air.

55. A method for forming the air filtration media pack according to claim 1, the method comprising coiling or stacking the single facer media.

FIG. 2

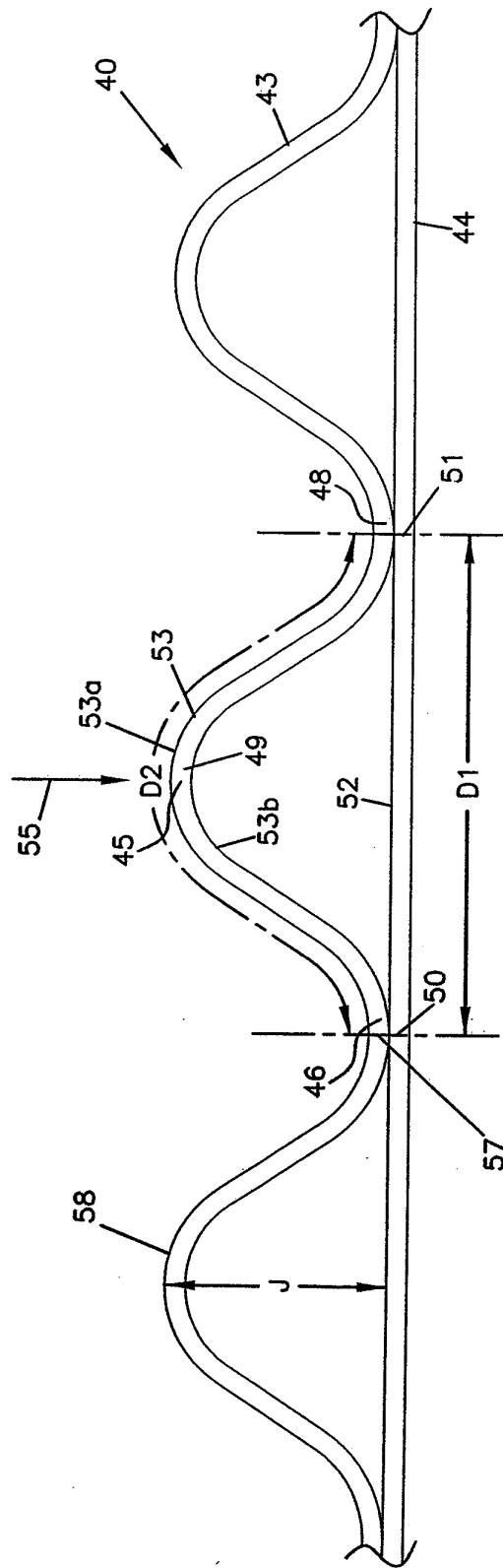

FIG. 3

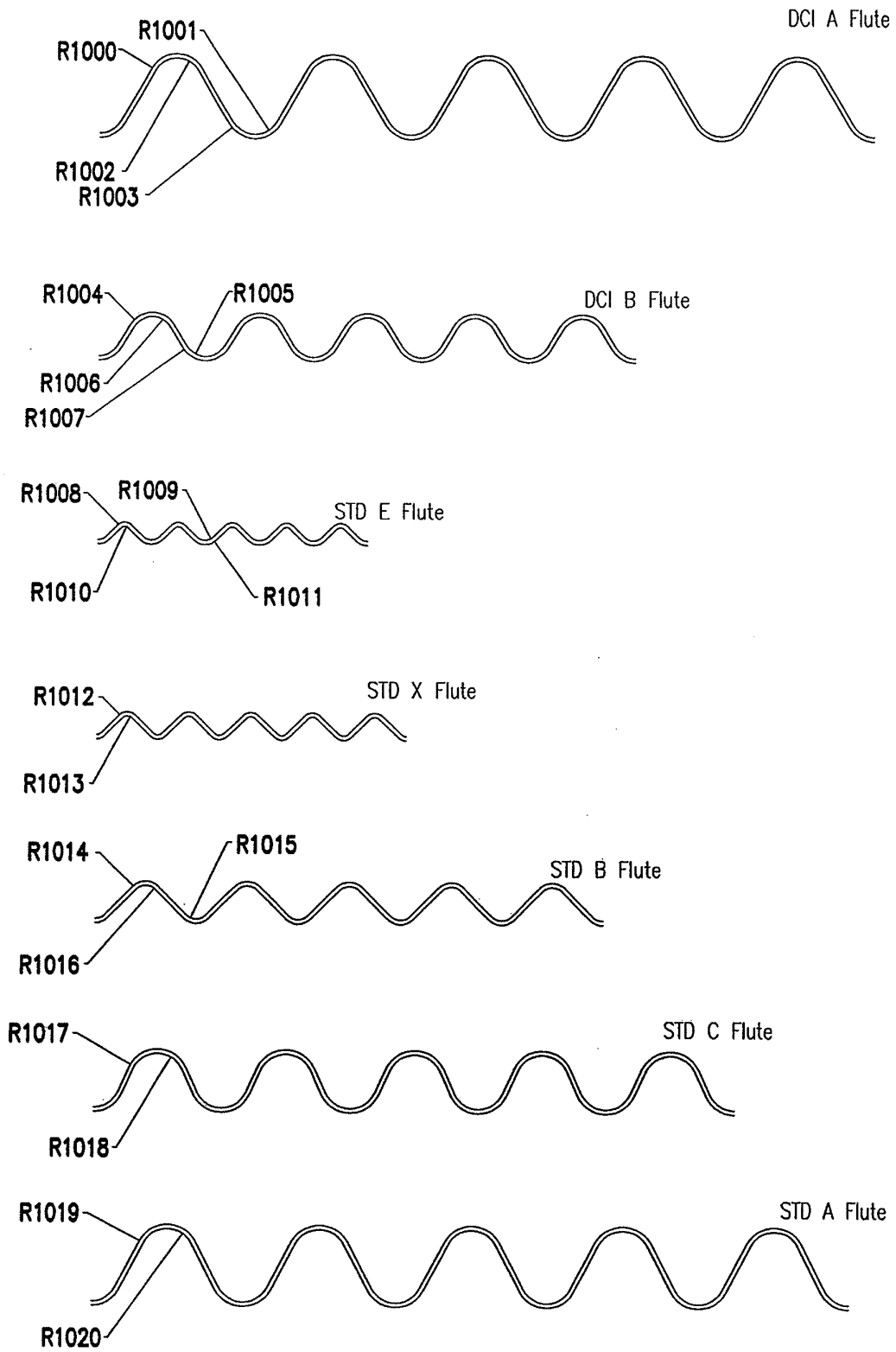

FIG. 4a

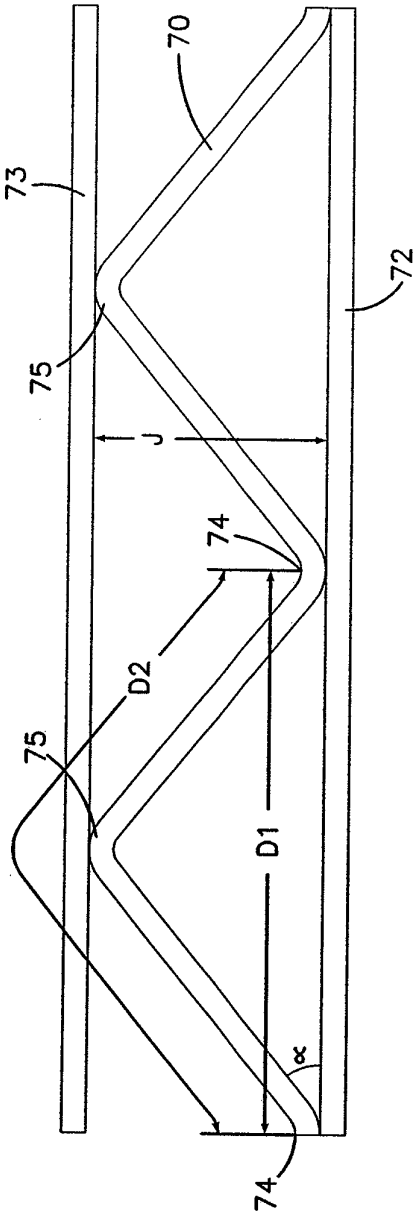

FIG. 4b

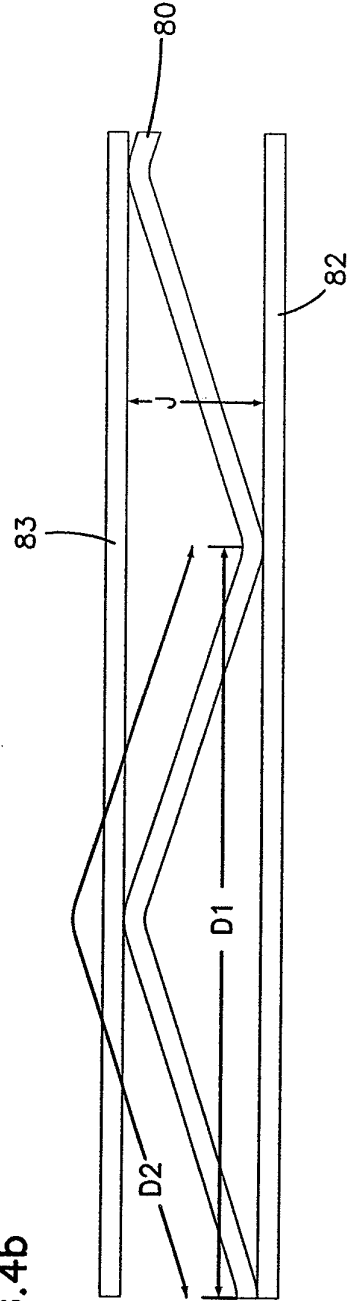
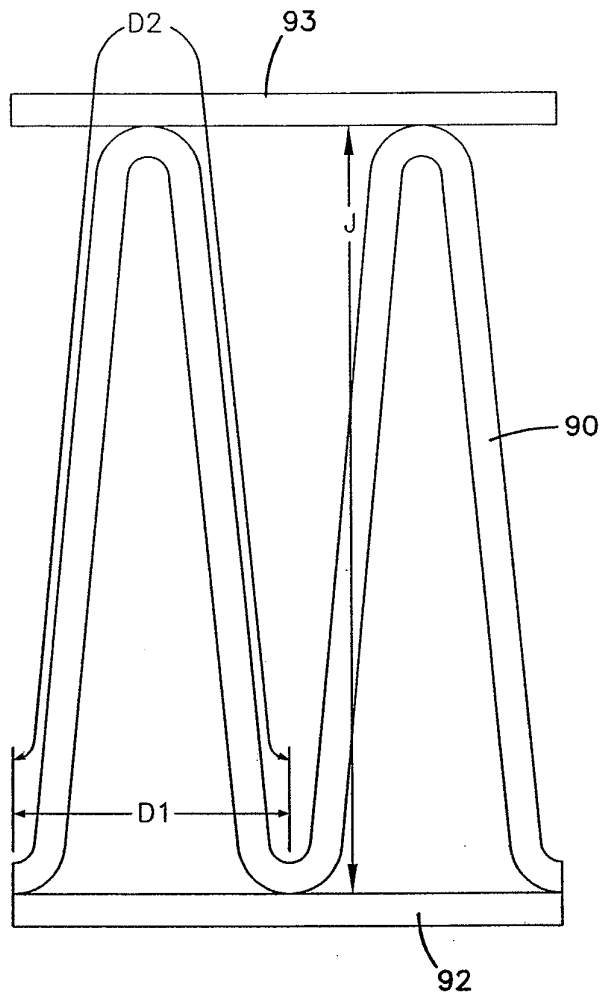

FIG.4c



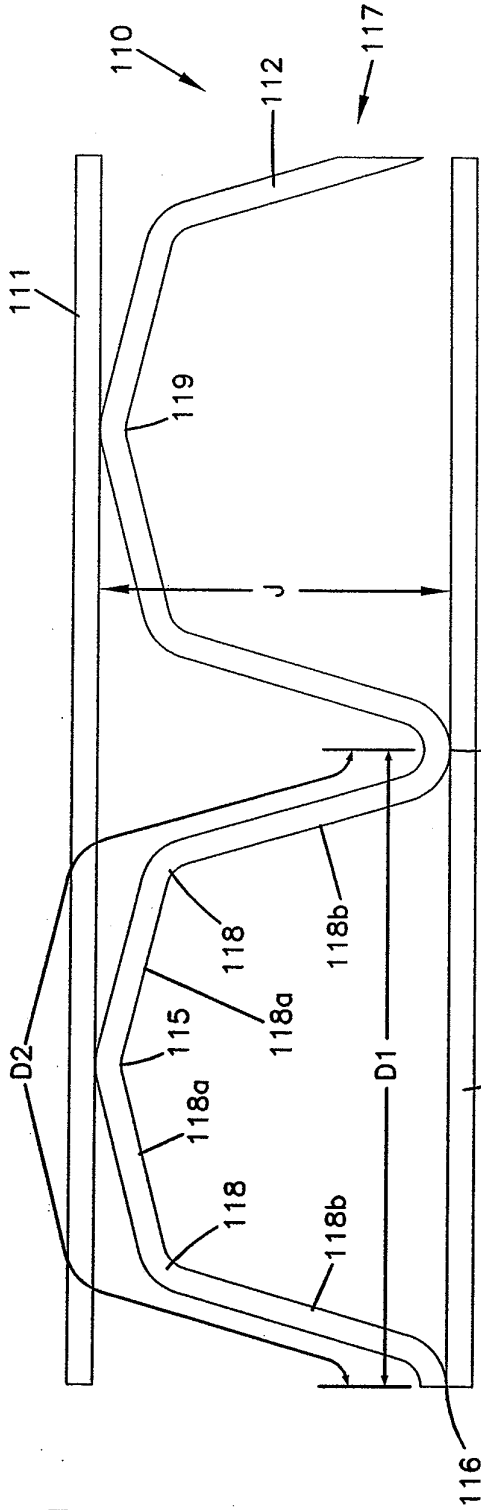

FIG. 5a

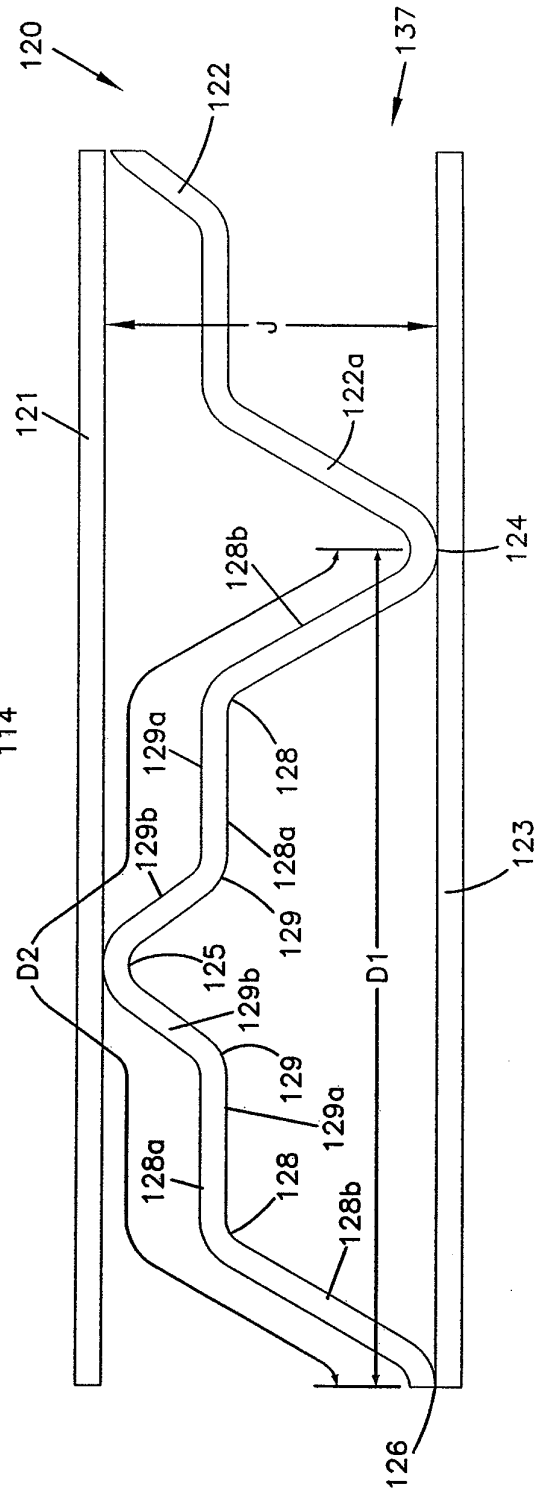
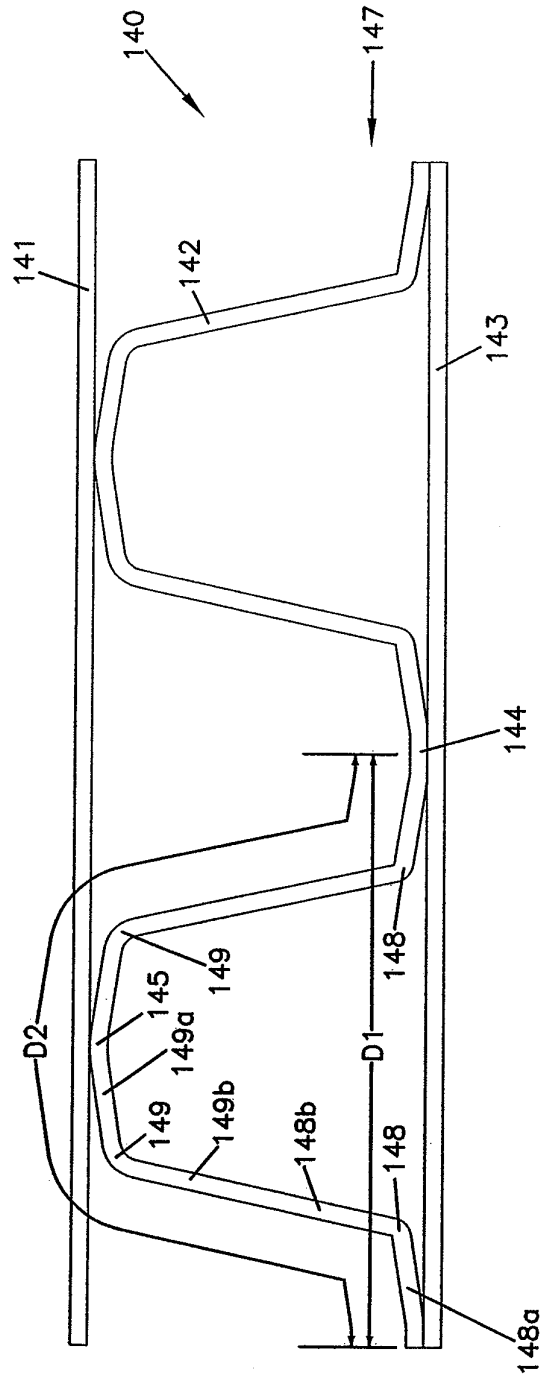

FIG. 5b

FIG. 5c



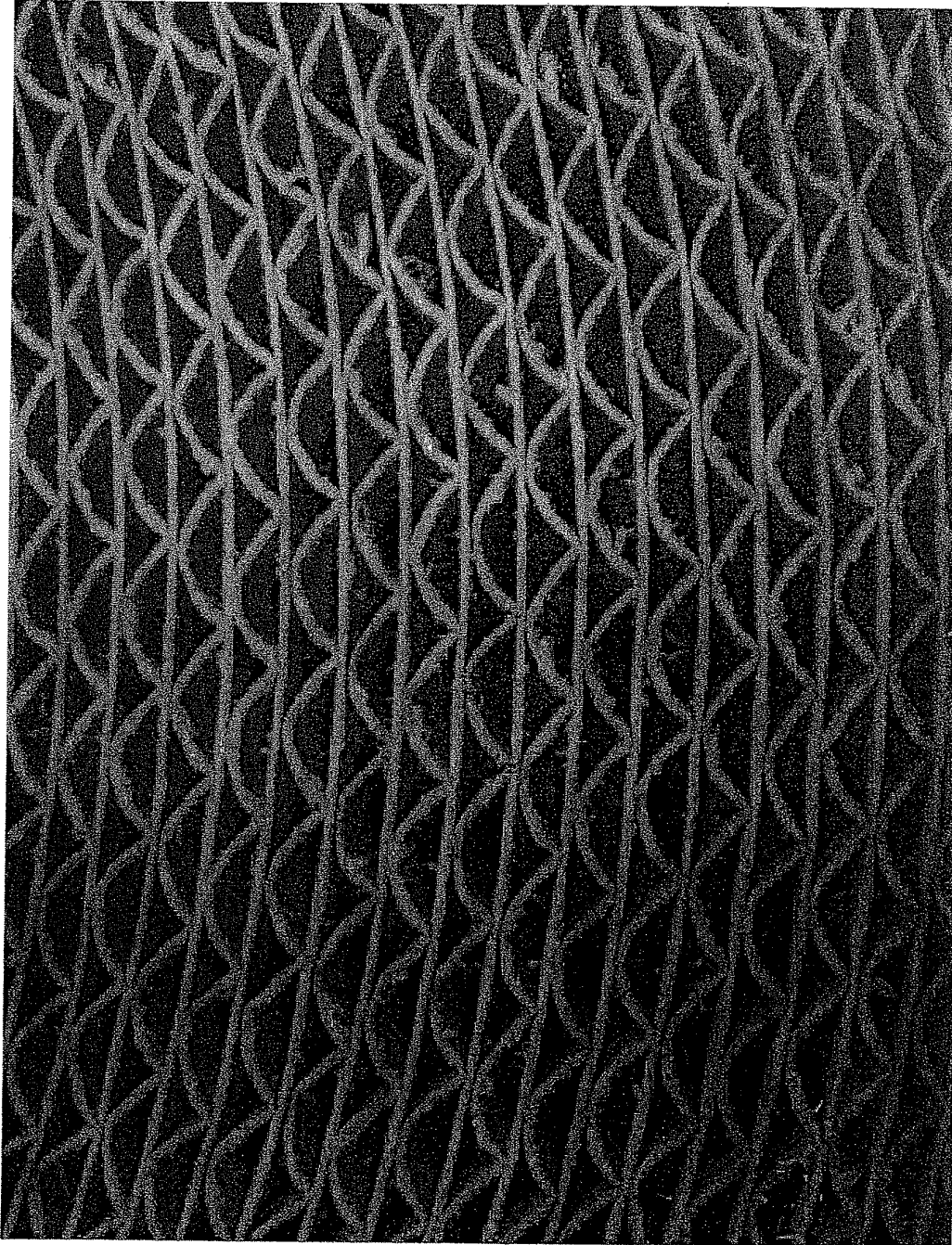

FIG. 6

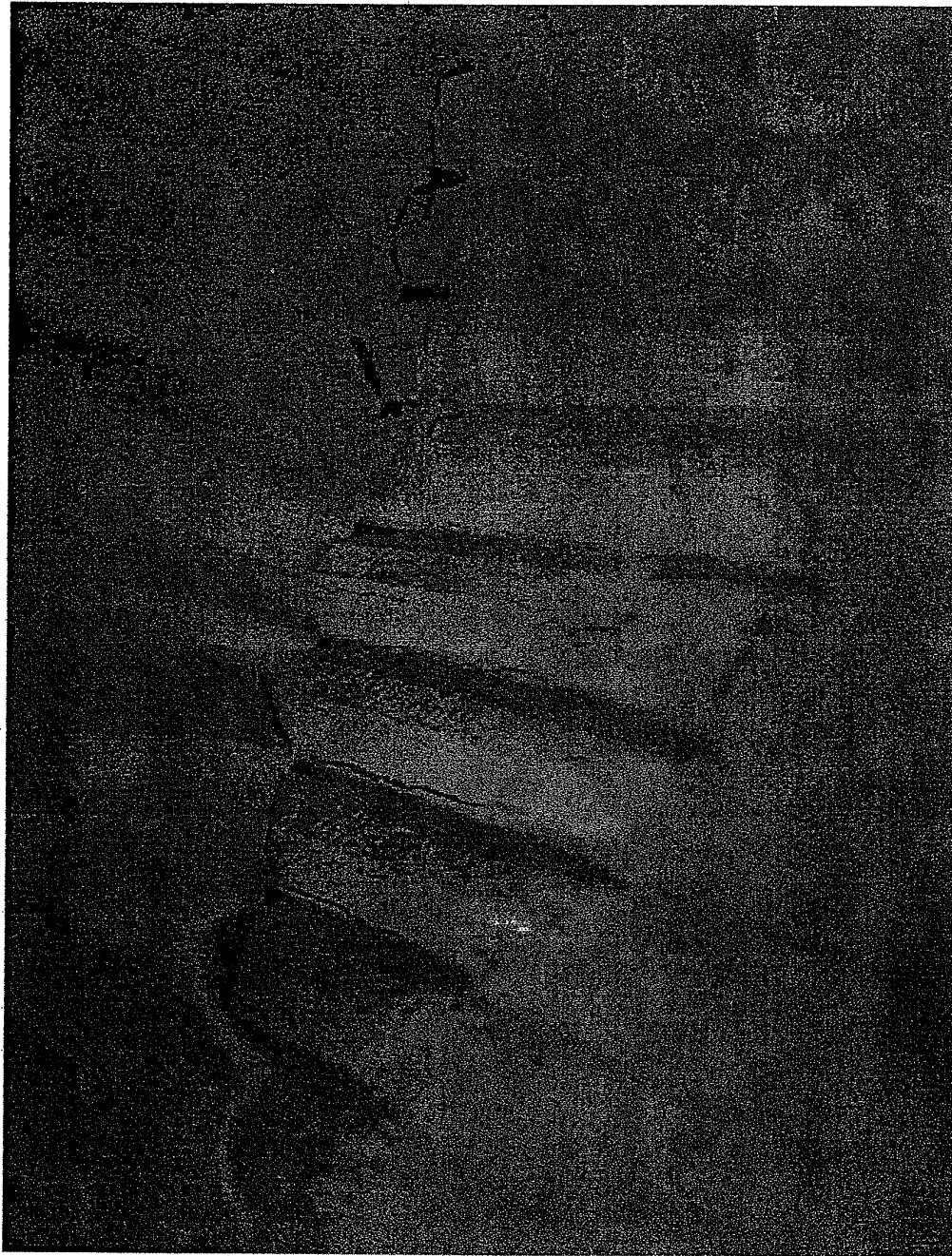

FIG. 7

FIG. 8

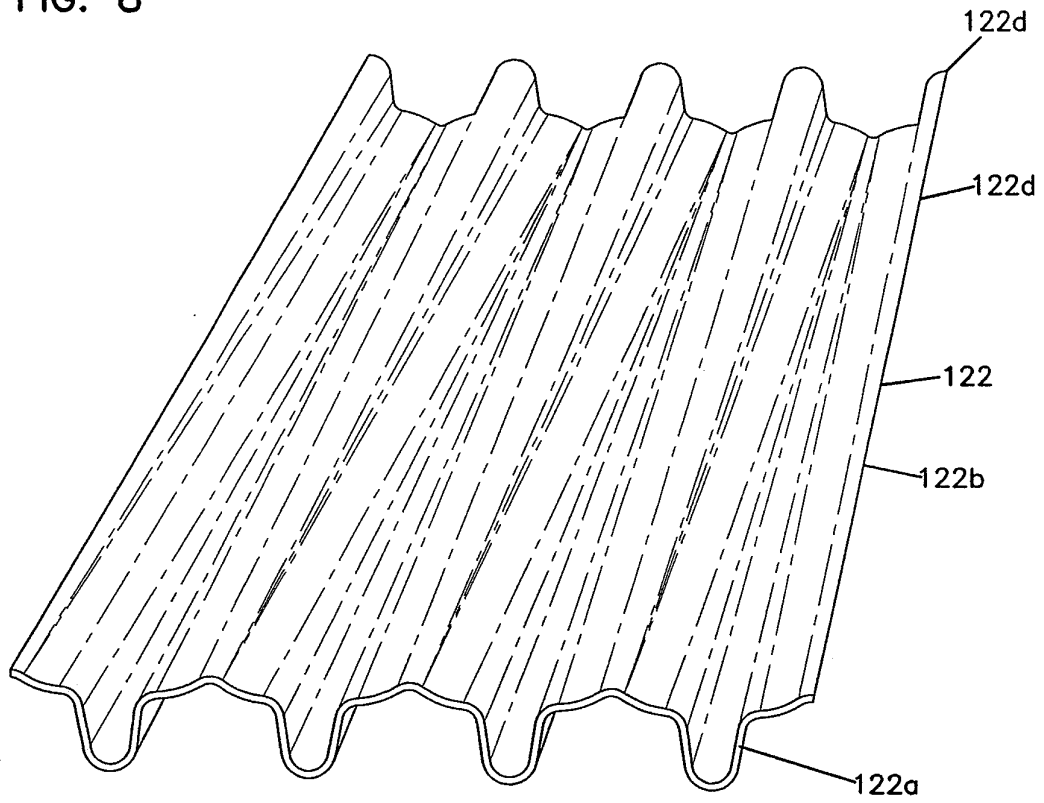

FIG. 9A

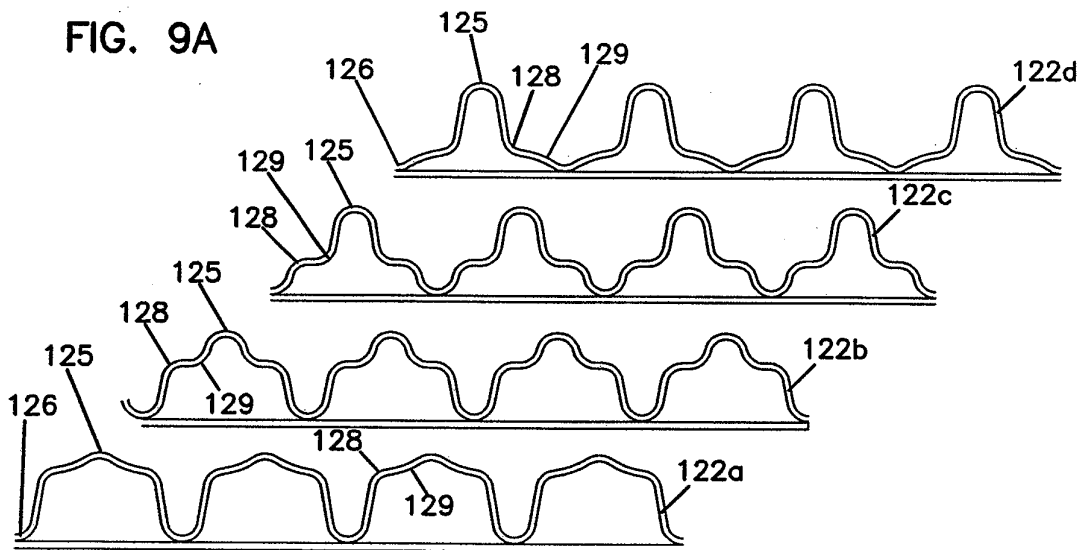
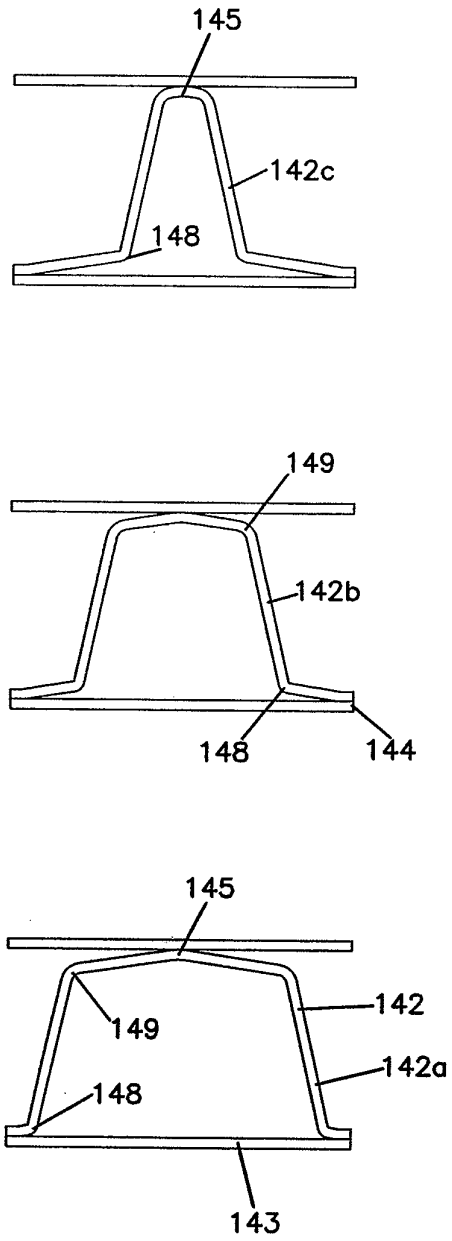
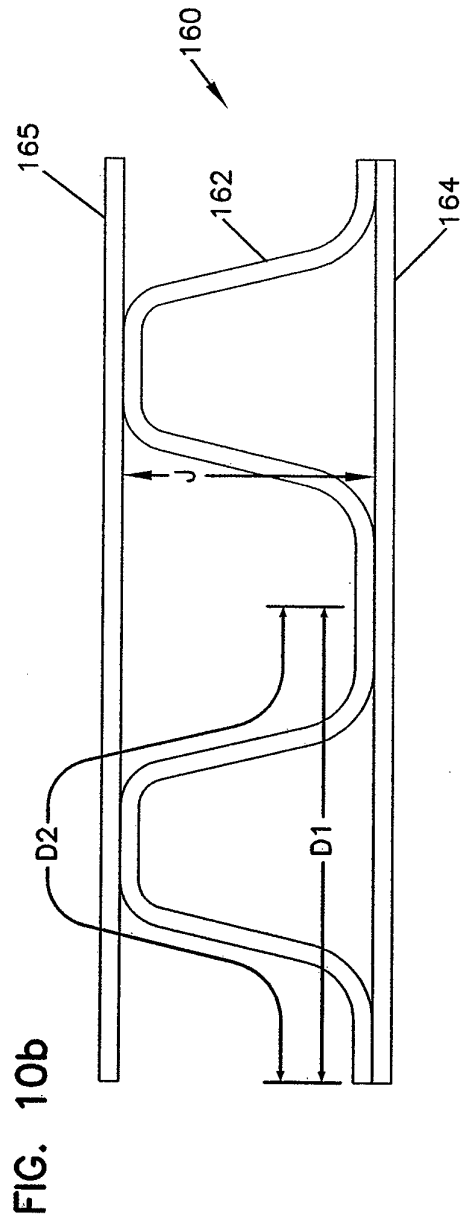
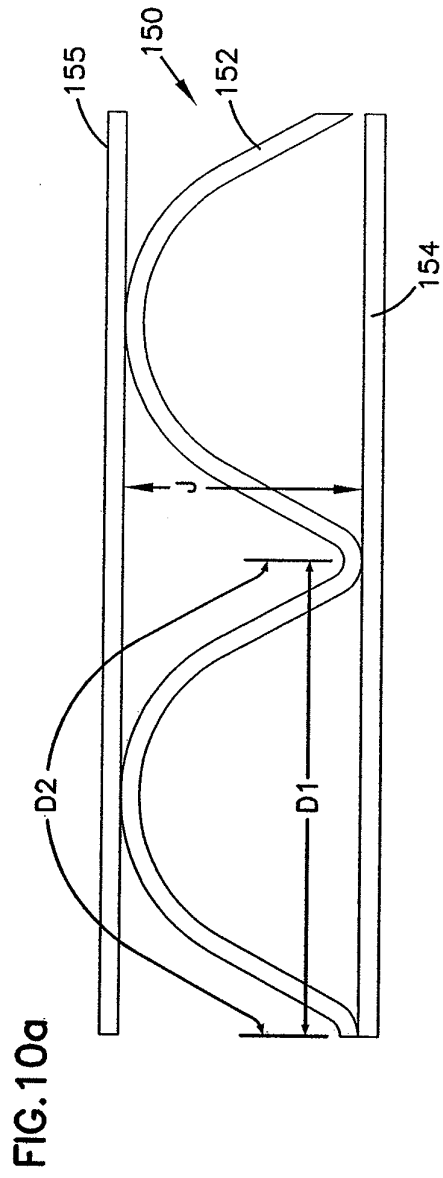

FIG. 9b





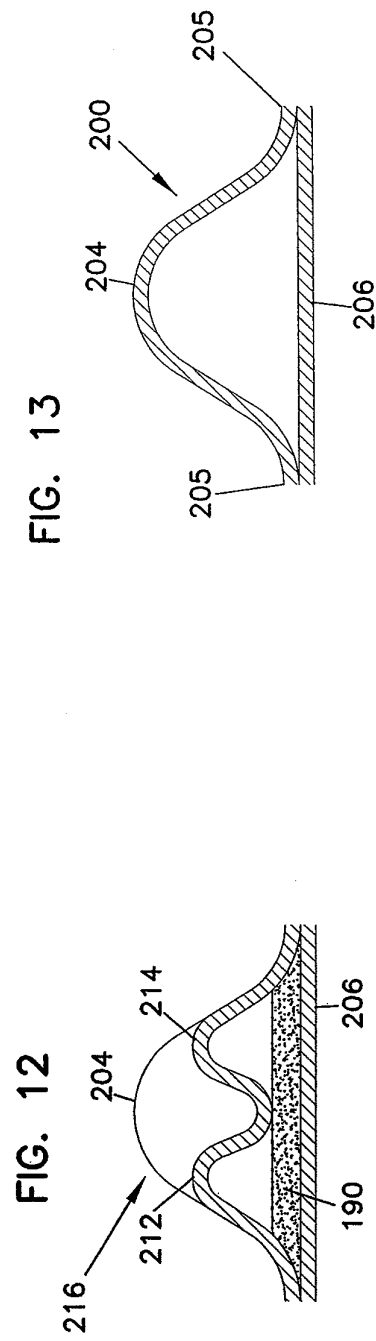
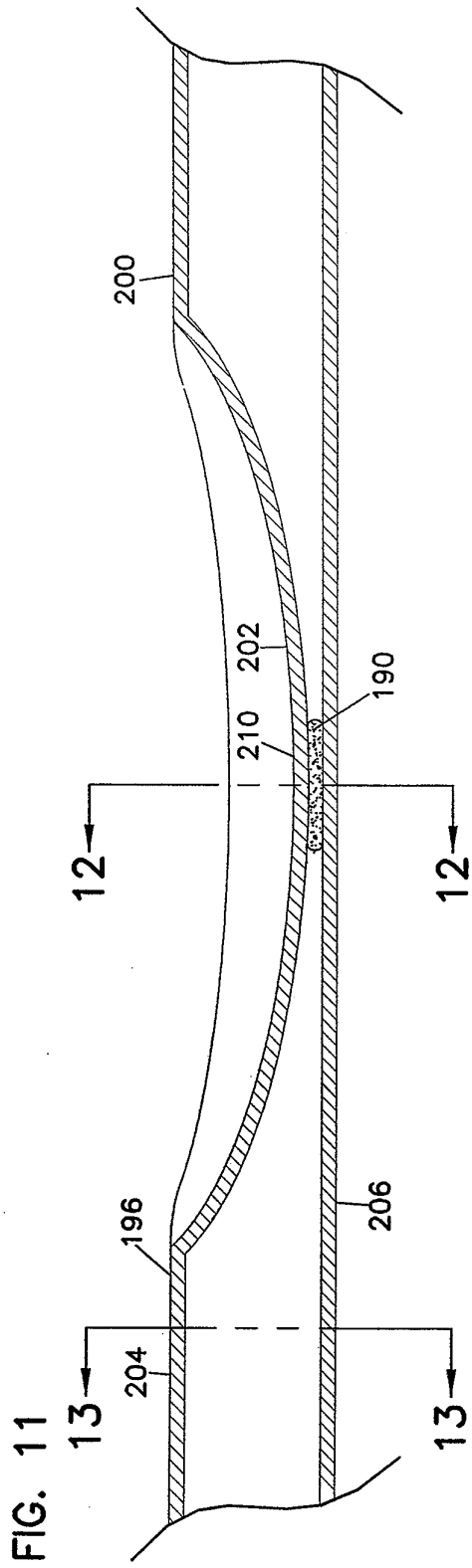

FIG. 13

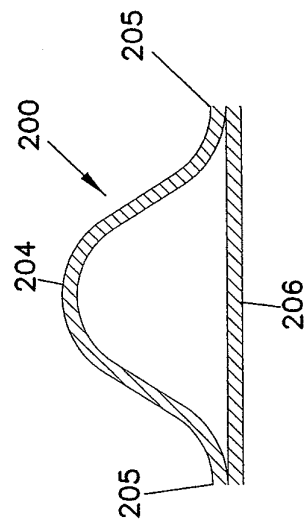

FIG. 14

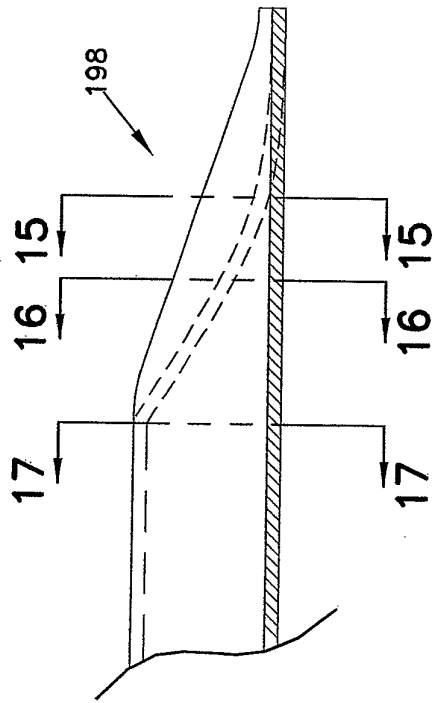

FIG. 18

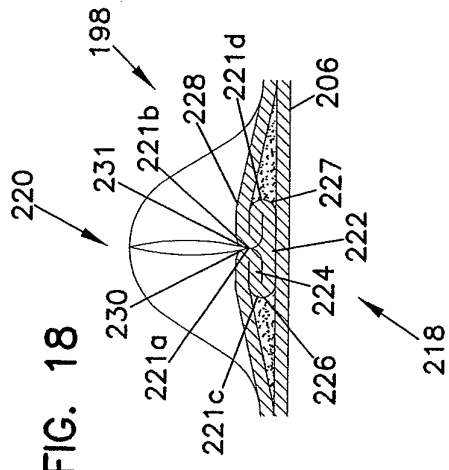

FIG. 17

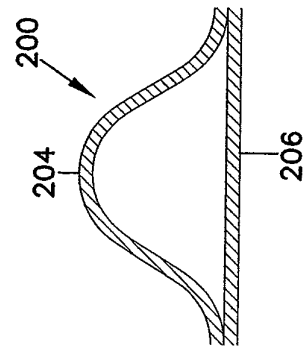

FIG. 16

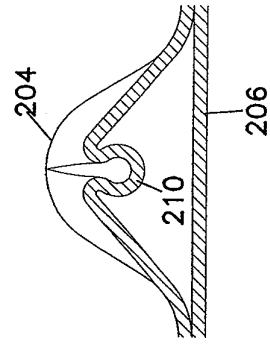

FIG. 15

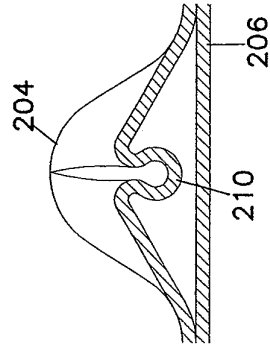
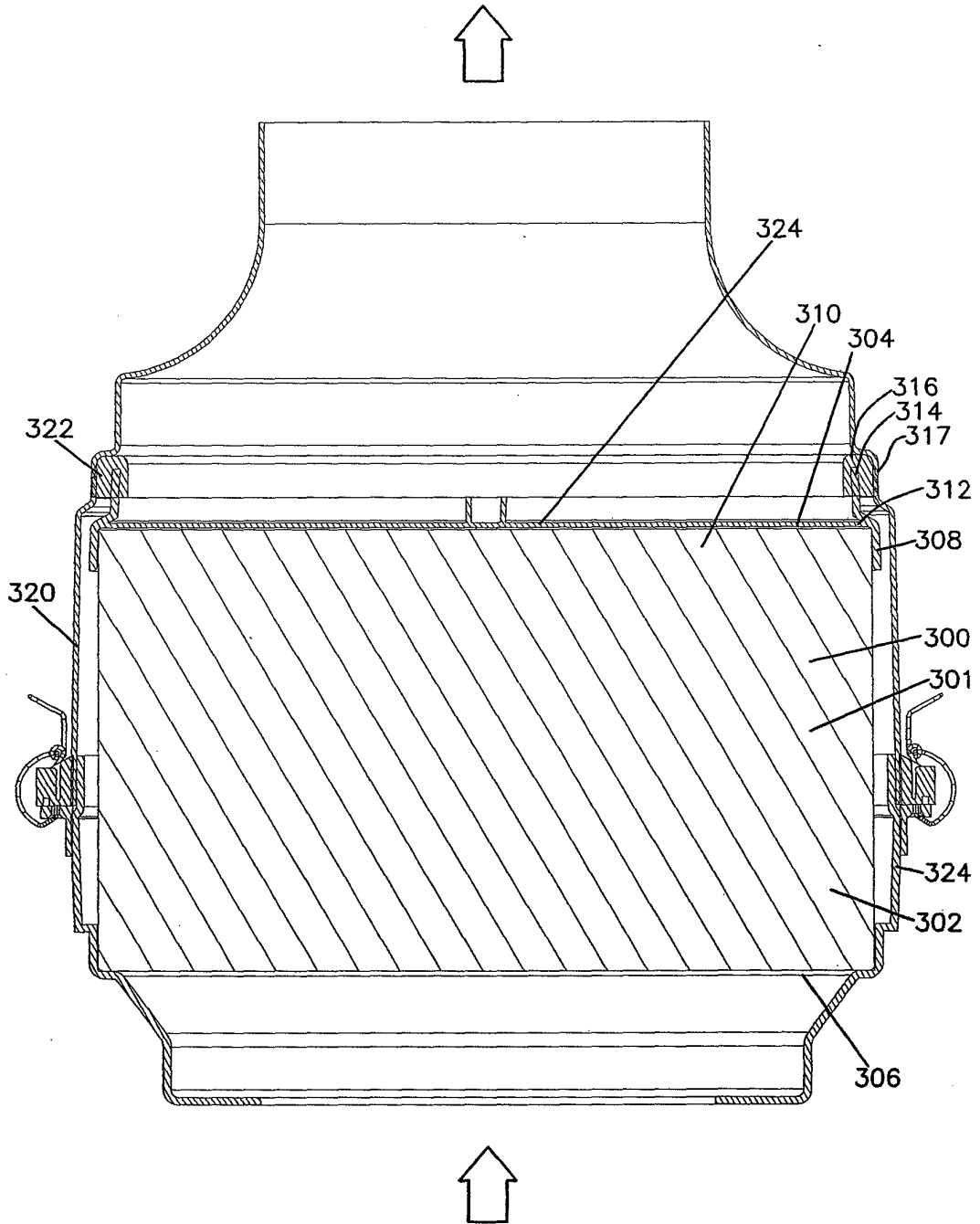

FIG. 19



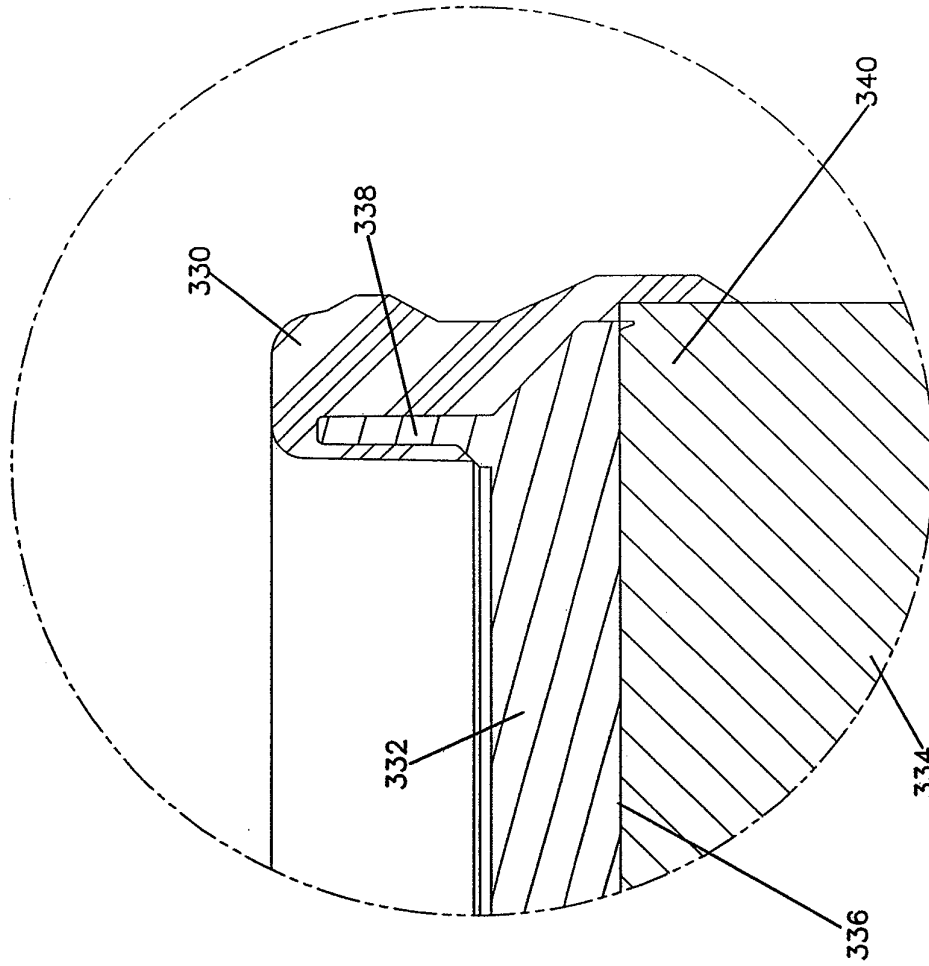

FIG. 20

17/24

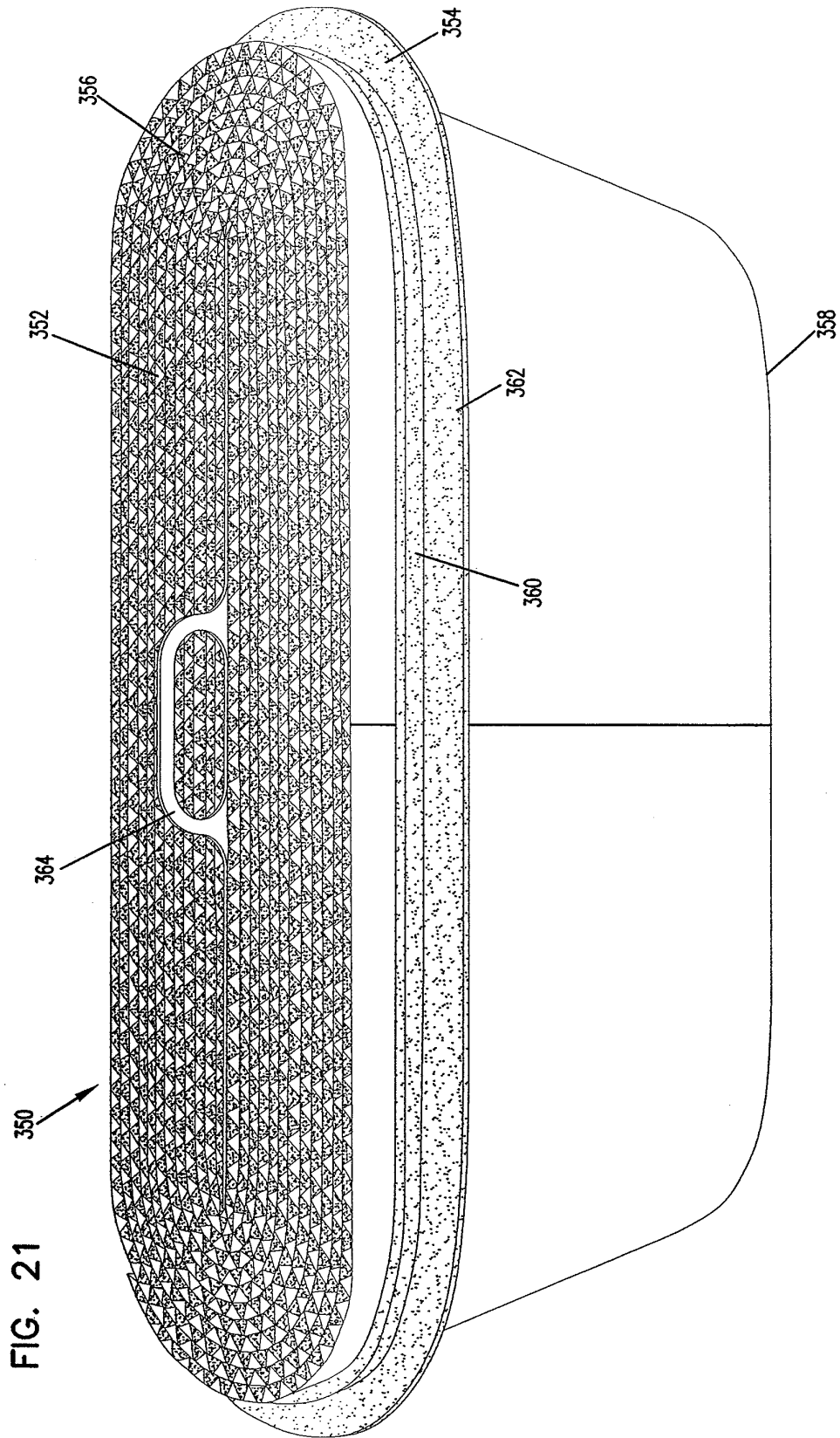

FIG. 22

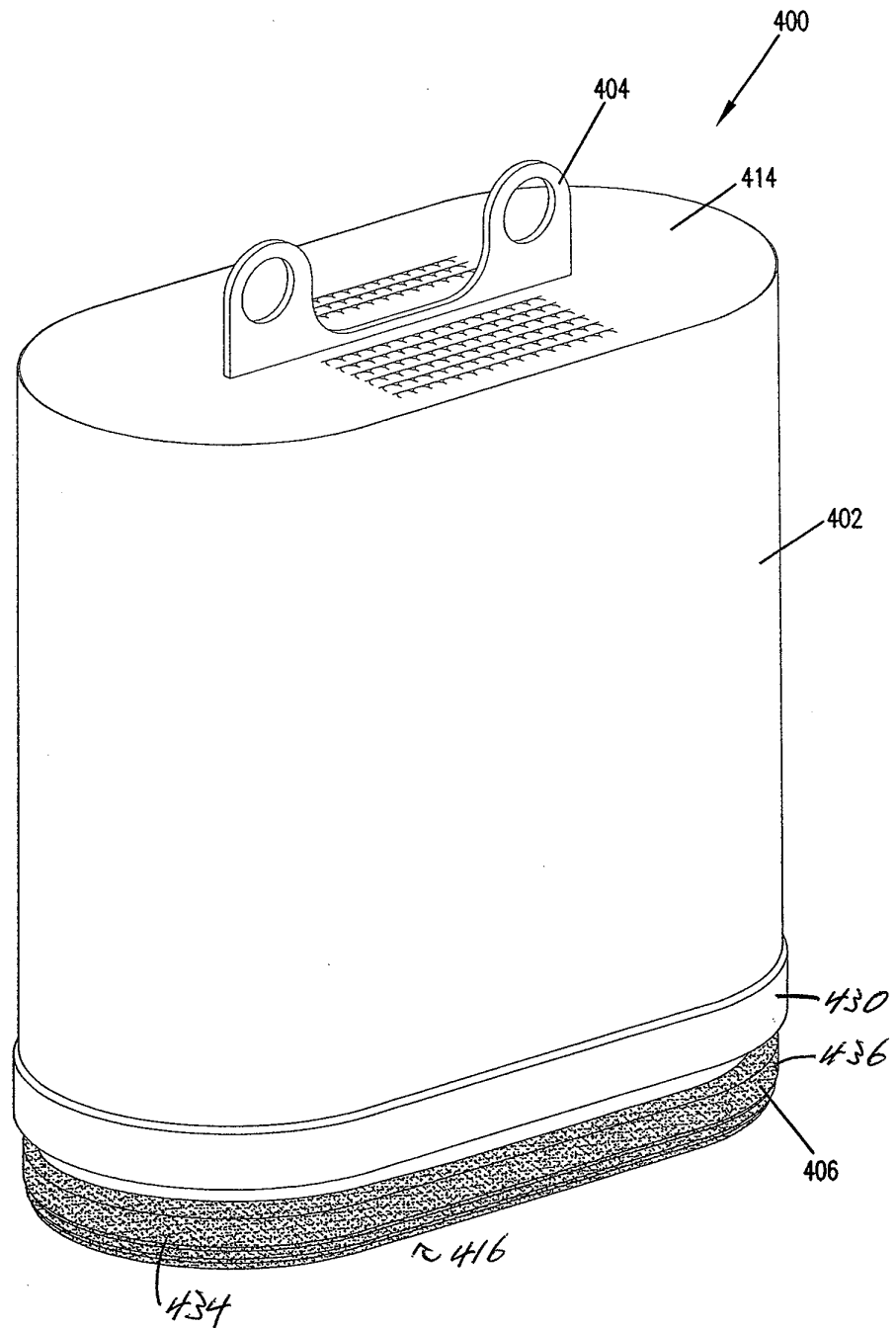

FIG. 23

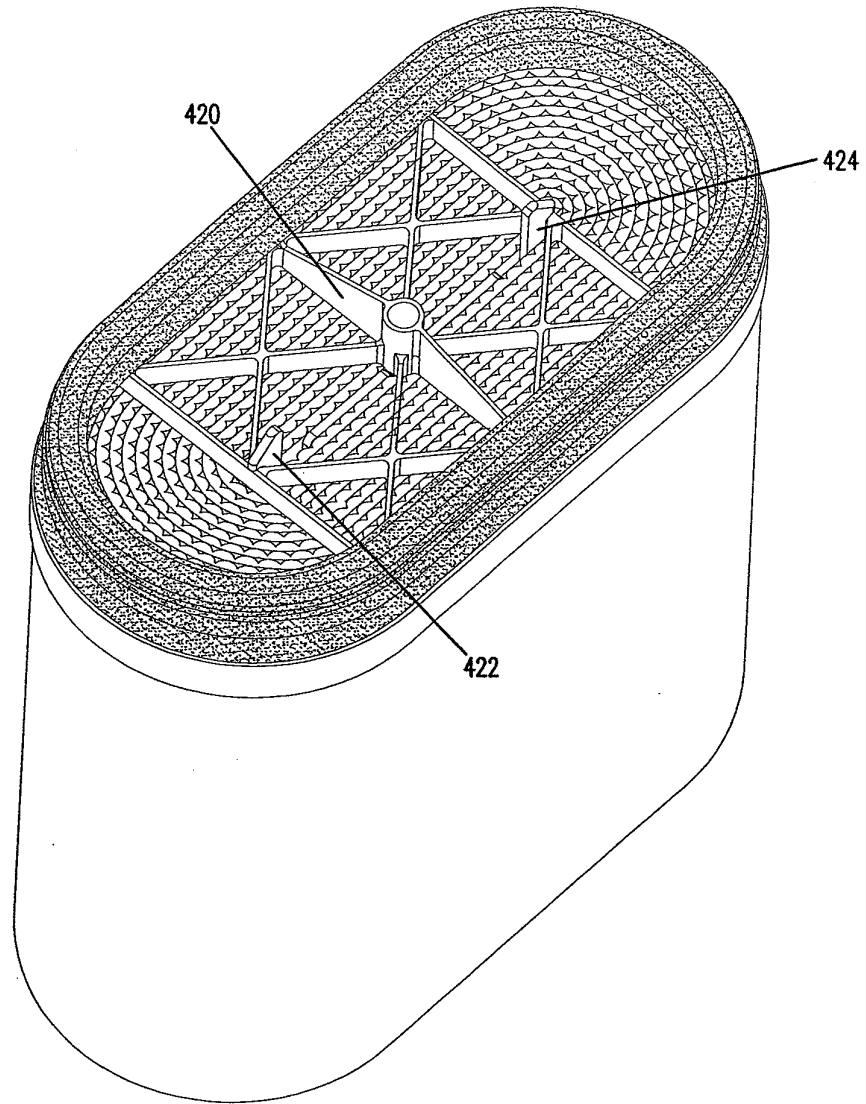

FIG. 24

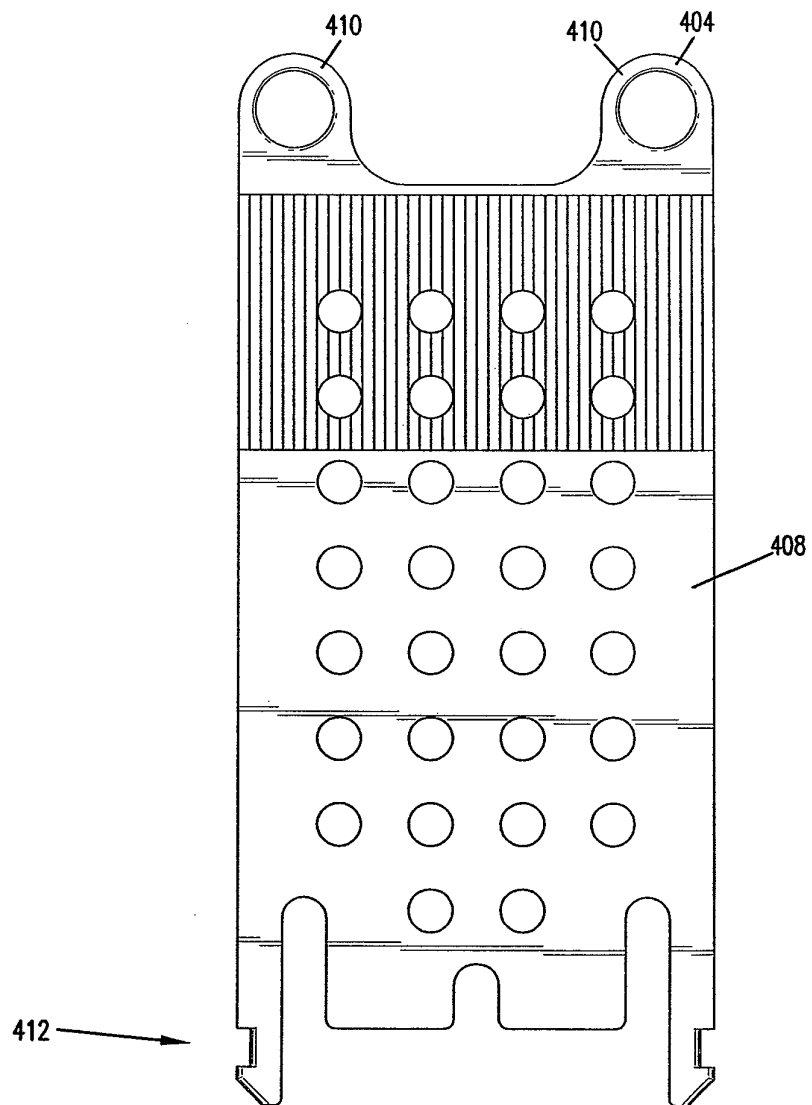
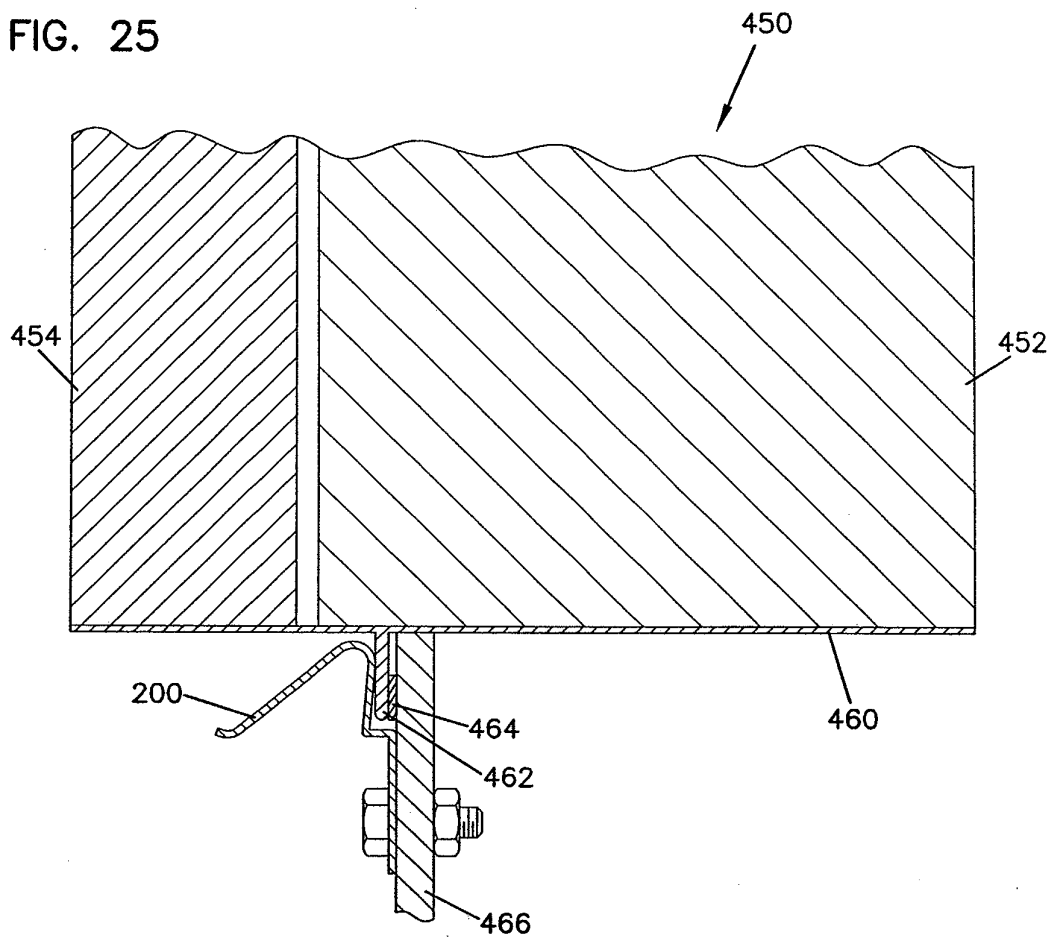

FIG. 25



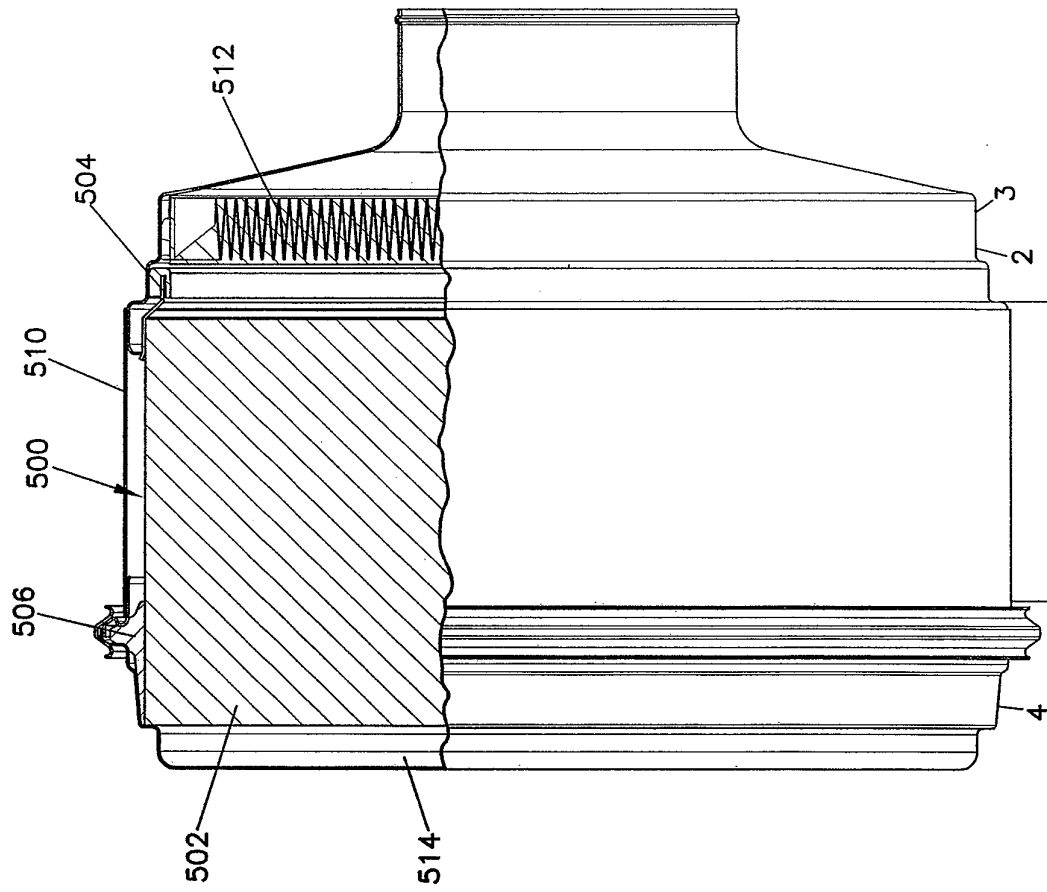

FIG. 26

