



(19) **United States**

(12) **Patent Application Publication**

**Lawson**

(10) **Pub. No.: US 2004/0088774 A1**

(43) **Pub. Date: May 13, 2004**

(54) **SURGICAL GARMENT AND OPERATING ROOM TABLE COVER**

(76) Inventor: **Mary Katherine Lawson**, Alpharetta, GA (US)

Correspondence Address:  
**DORITY & MANNING, P.A.**  
**POST OFFICE BOX 1449**  
**GREENVILLE, SC 29602-1449 (US)**

(21) Appl. No.: **10/290,995**

(22) Filed: **Nov. 8, 2002**

**Publication Classification**

(51) **Int. Cl.<sup>7</sup> ..... A41B 1/00; A41D 1/00**

(52) **U.S. Cl. .... 2/69**

(57) **ABSTRACT**

A surgical garment and a method is provided. The surgical garment includes a body portion that extends over at least

part of the back and at least part of the front of the patient. The body portion is fluid resistant and is made of a material that reduces heat transfer to the environment. The body portion has at least one opening section, and has a pair of arm openings for accommodating the arms of the user. An attachment mechanism is carried by the body portion. The attachment mechanism is configured to releasably attach and detach the body portion such that the opening section is closed and opened. During detachment of the attachment mechanism, the body portion is configured to at least partially cover an operating table to protect the table from contaminants. The body portion may extend over the sides of the operating table. The method includes the step of covering the patient with a surgical garment that has at least one material therein that reduces heat transfer from the patient to the environment. The method also includes the steps of positioning the patient on the operating table and applying anesthesia to the patient. Further, the method includes the step of opening the surgical garment so that the surgical garment covers at least a portion of the operating table and prevents contamination of the operating table during a surgical procedure.

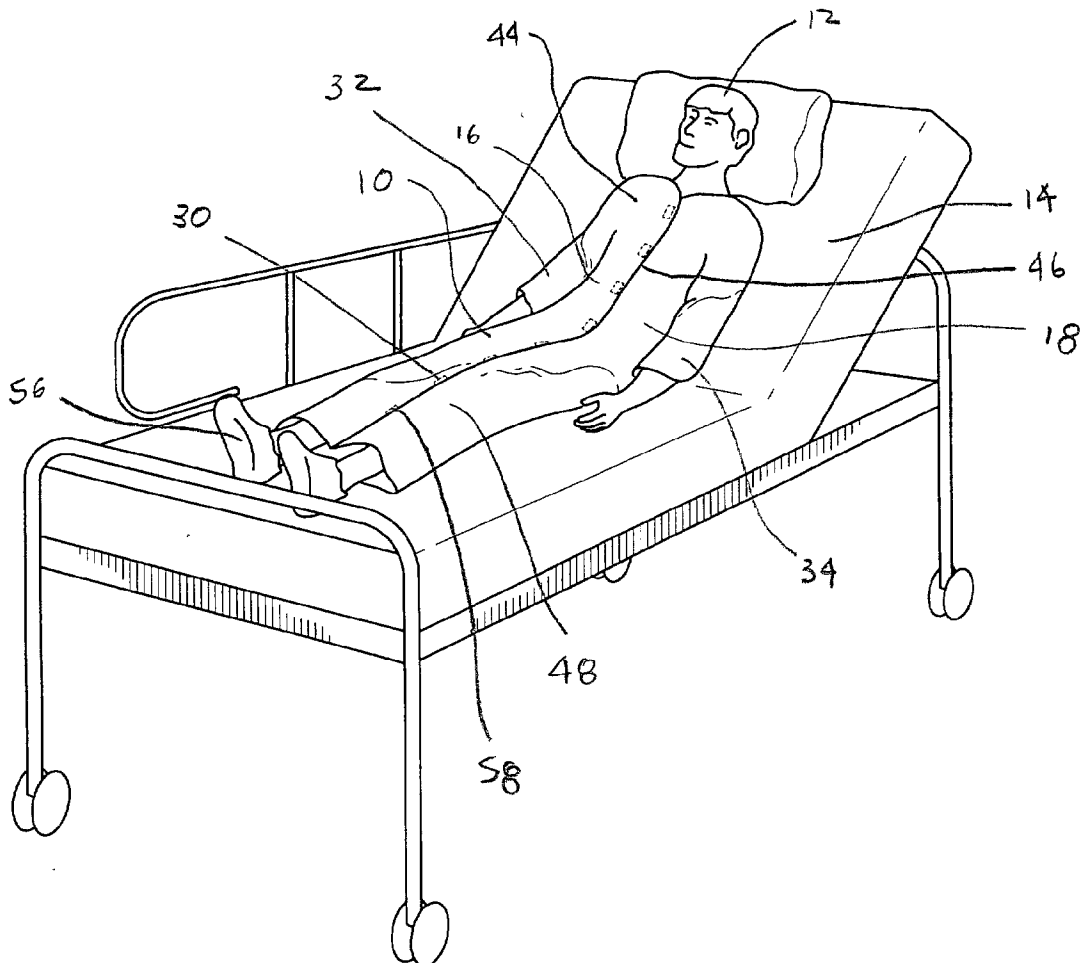

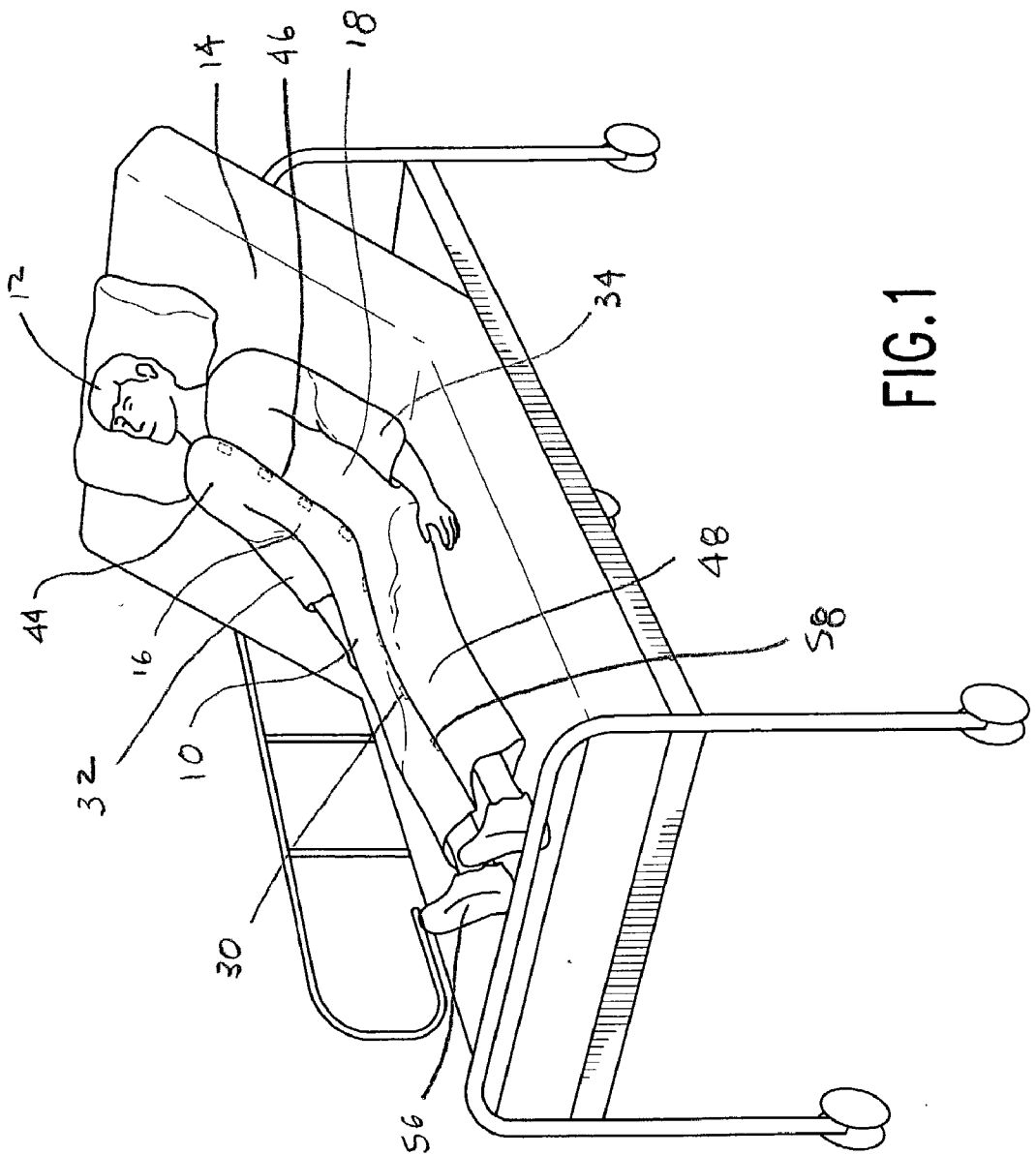

FIG. 1



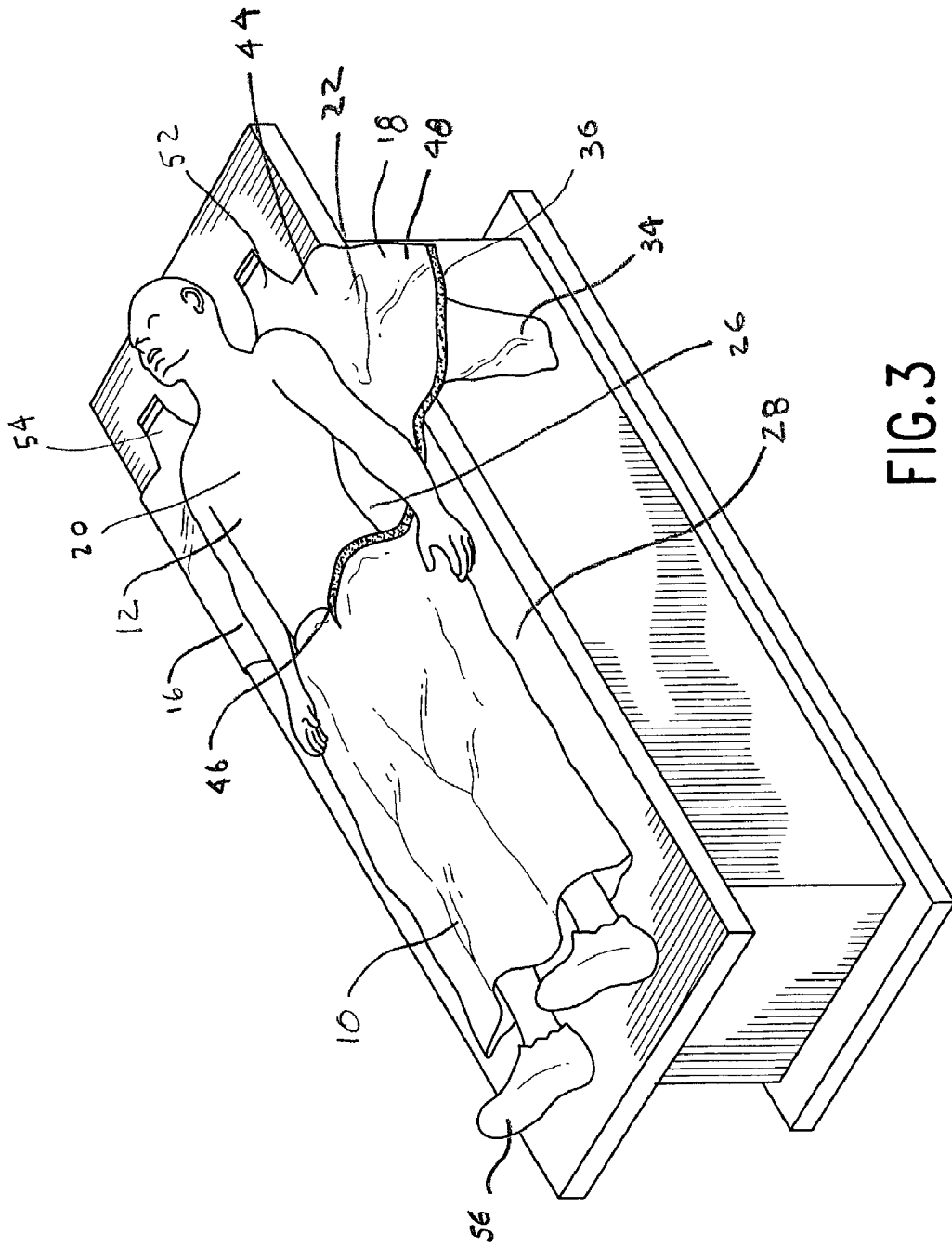

FIG. 3

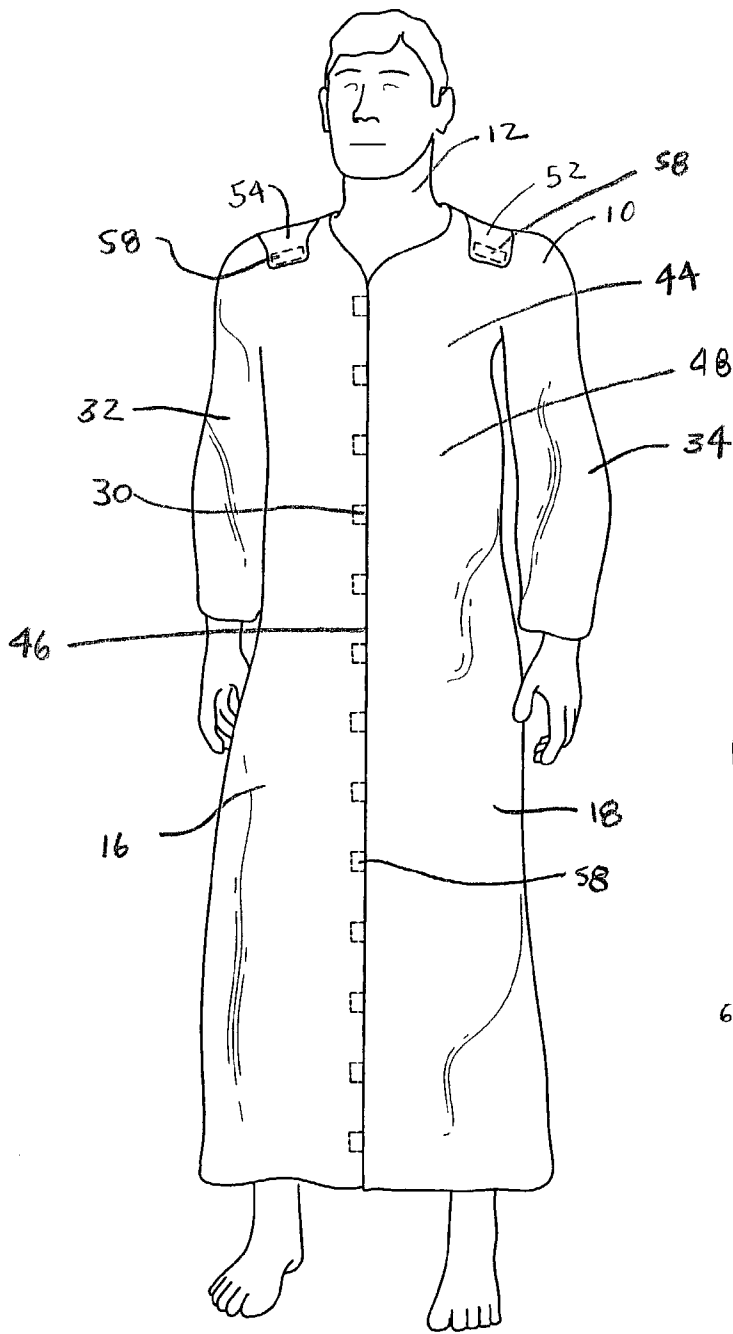

FIG. 4

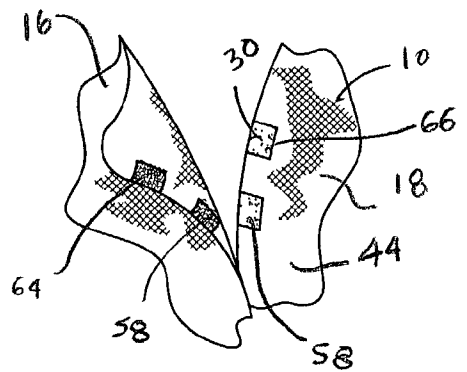

FIG. 4A

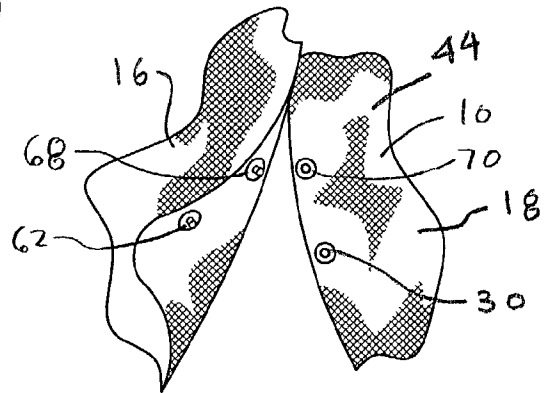
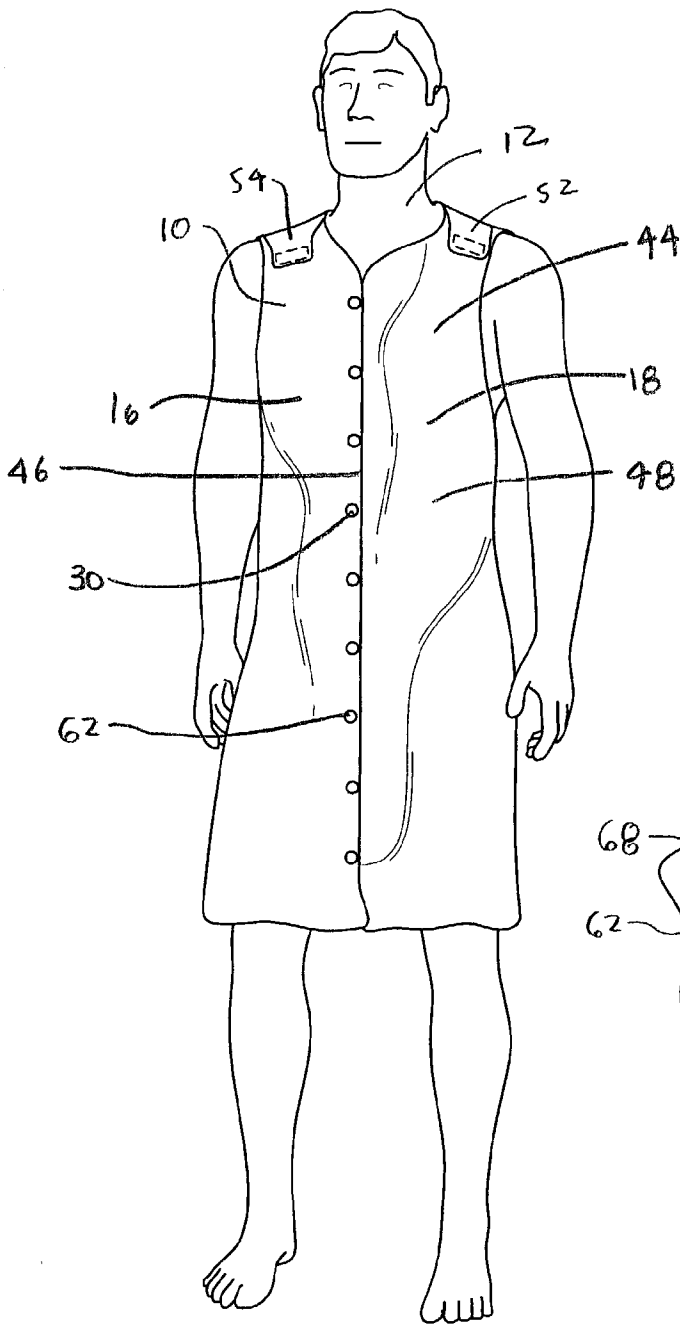

FIG.5A

FIG.5

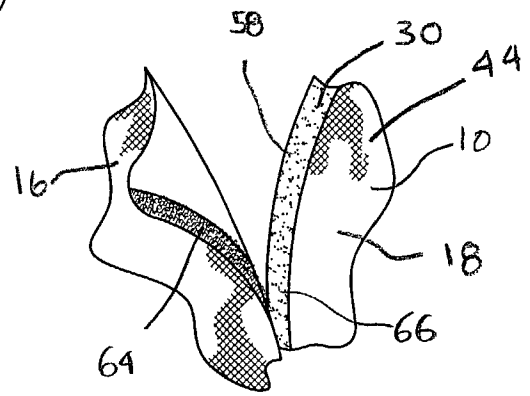
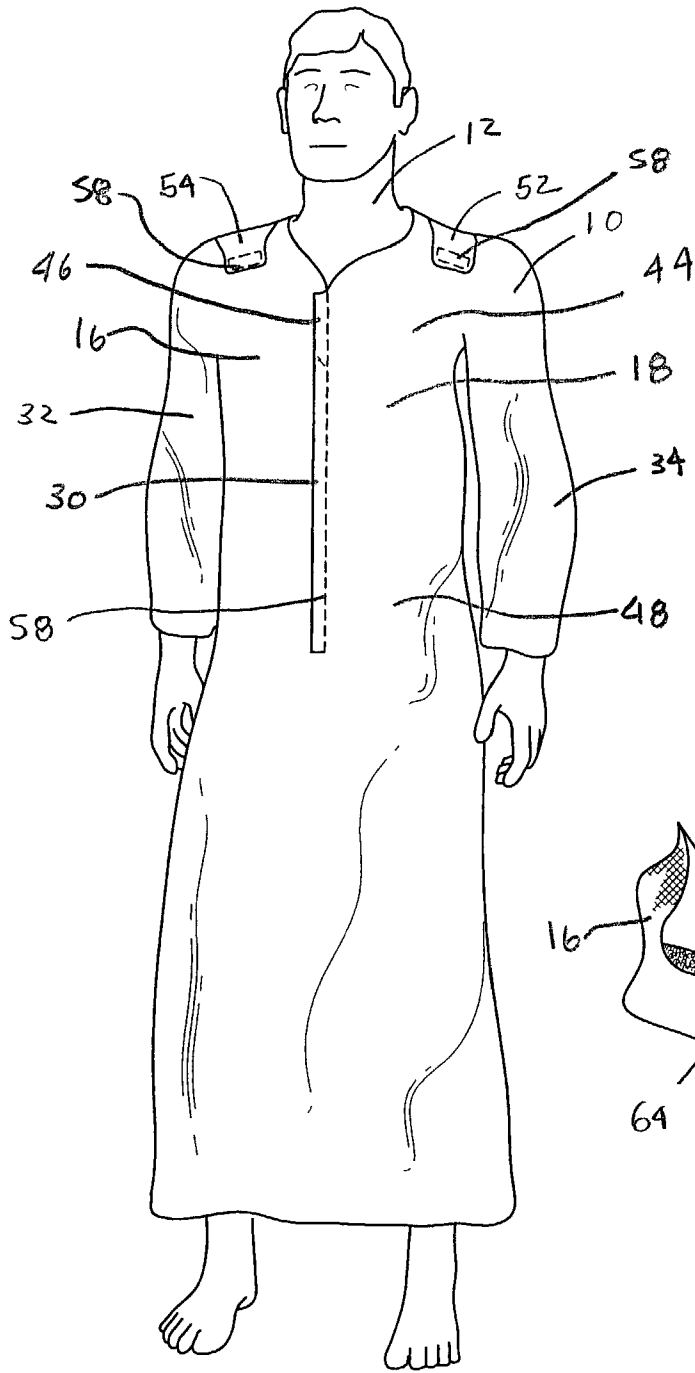

FIG. 6A

FIG. 6

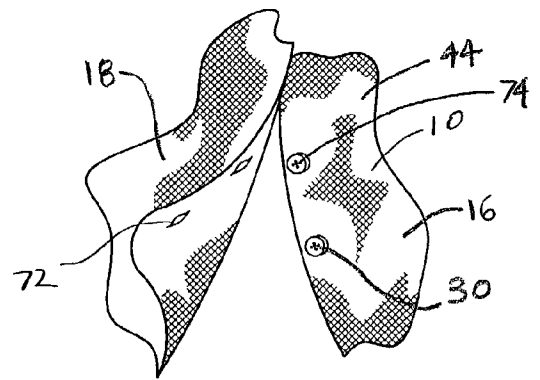
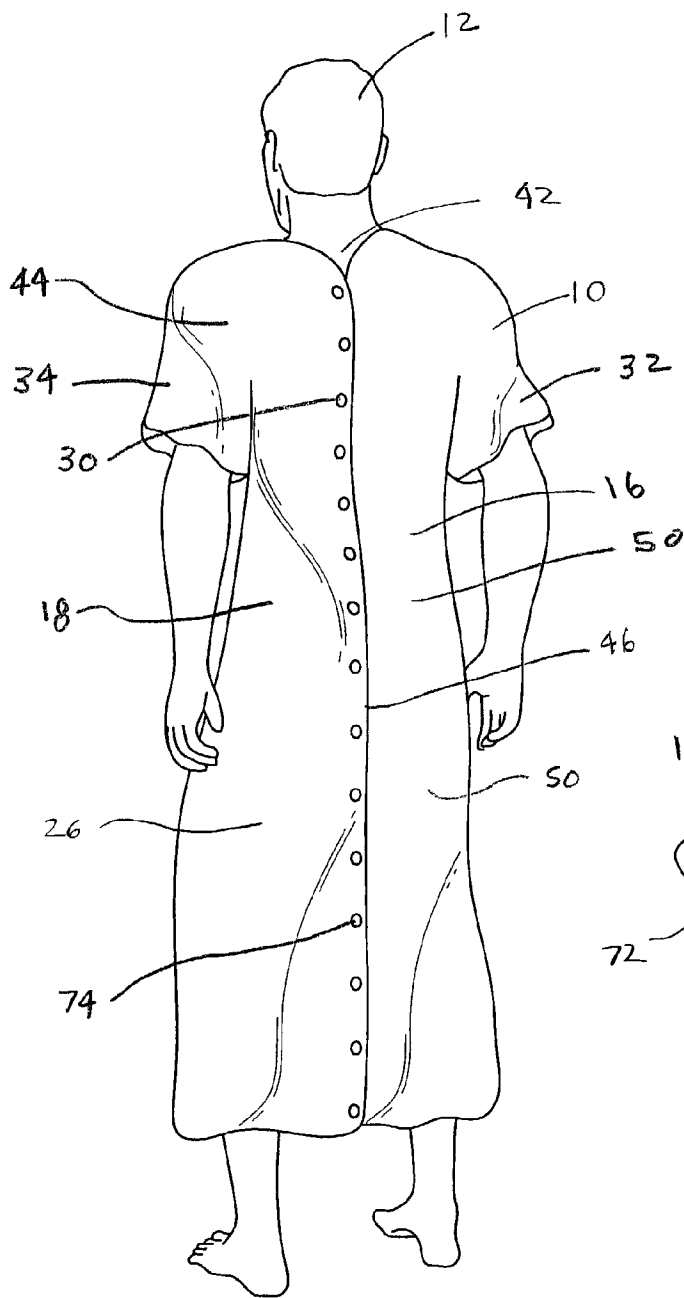

FIG. 7A

FIG. 7



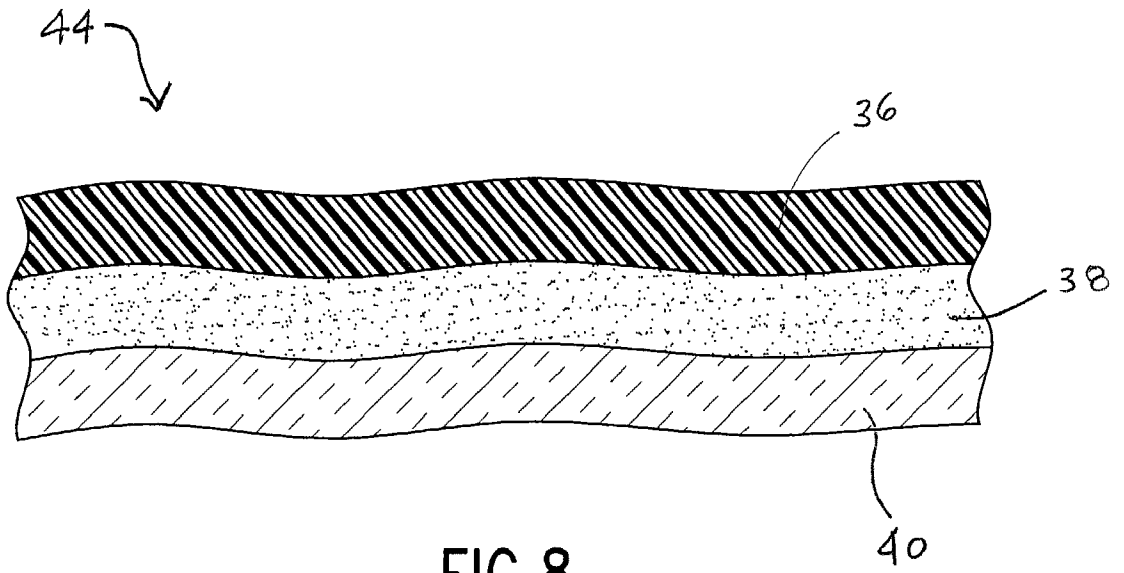

FIG.8

## SURGICAL GARMENT AND OPERATING ROOM TABLE COVER

### BACKGROUND

[0001] Patients that wait in pre-op rooms and operating rooms often comment on the uncomfortable coldness of the room's temperature. In preparing for surgery, a patient is normally clothed with an operating gown that has an open back. The gown usually extends down to the thighs of the patient, and has either short or no sleeves. As can be imagined, this type of garment provides very little warmth to the patient and is of little aid in maintaining the body temperature of the patient in a slightly cold room or in a room of normal temperature. As such, it is often the case that patients complain of being cold in pre-op and in operating rooms.

[0002] Heat loss before, during, and after surgical procedures may lead to hypothermia in the patient. This hypothermia may also be caused in part by anesthesia that is delivered to the patient that suppresses the thermo regulating region of the brain. Also, general anesthesia and muscle relaxants tend to prevent a patient from shivering, which is a common mechanism by which the body retains heat. As can be seen, hypothermia in patients is a concern due to the aforementioned circumstances surrounding a surgical procedure.

[0003] Pediatric patients and elderly patients carry greater risks of hypothermia than adults. Infants, for instance, may be unable to maintain adequate body temperature because of dehydration, diarrhea, and weakness which along with the aforementioned conditions serve to increase heat loss. Low body temperature is one of the most common causes of the stoppage of breathing following general anesthesia. Elderly patients are also especially susceptible to hypothermia since they have a decreased ability to prevent heat loss through shivering. With age, cardiovascular and pulmonary physiology declines, resulting in a lessening in the capacity to retain heat through this mechanism.

[0004] In order to prevent heat loss in patients, it is sometimes the case that patients in a pre-operative area are covered by a sheet or a blanket. The patient may then be transported to the operating room, in which he or she remains covered by the same sheet or blanket until under going anesthesia. It is therefore the case that specialized products such as surgical gowns do not exist in order to keep a patient warm while awaiting surgery.

[0005] Products do exist to warm the patient during operating room procedures. These products may include the Bair Hugger® system from Augustine Medical, KanMed Patient Warmer Accessories from Medical Devices Pty Ltd., reflective disposable insulation Thermadrapes® from O.R. Concepts, Inc., and the CareQuilt® Full-Body Multi-Access Warming Blanket from Tyco/Mallinckrodt.

[0006] Another concern during surgery is that blood, fluids, and other contaminants are often dropped onto the operating table onto which the patient is positioned. It is sometimes the case that disposable covers are placed on top of the operating room table in order to prevent these contaminants from contacting and remaining on the table. This situation is undesirable in that if these contaminants were to remain in the operating room, they may be transferred to subsequent patients during future surgeries.

[0007] Current products that are used to help warm the patient during surgery are not designed for preventing contamination from being transferred to the operating table. These products are only designed to cover the patient, and are not designed to cover the operating table itself. Further, gowns and other products that are designed for use in the pre-op area also do not prevent the transfer of contamination to the operating room table during surgery.

### SUMMARY

[0008] Various features and advantages of the invention will be set forth in part in the following description, or may be obvious from the description, or may be learned from practice of the invention.

[0009] The present invention provides for a surgical garment for use with a patient. The surgical garment may be configured as a cover in order to prevent contamination to an operating table and/or may be configured as a garment that prevents heat loss to the patient until anesthesia is applied.

[0010] In one exemplary embodiment, the surgical garment includes a body portion that extends over at least part of the back and at least part of the front of the patient. The body portion has at least one opening section. The body portion also has a pair of arm openings for accommodating the arms of the user. The body portion is fluid resistant and may be made of a material that reduces heat transfer from the patient to the environment. An attachment mechanism is carried by the body portion. The attachment mechanism is configured to releaseably attach and detach the body portion so that the opening section may be closed and opened. During detachment, the body portion is configured to at least partially cover an operating table to protect the table from contaminants. The body portion may extend over the sides of the operating table.

[0011] Also included in the present invention is a surgical garment as discussed above where the opening section extends from the neck of the patient to the feet of the patient on the front of the body portion.

[0012] Another exemplary embodiment of the present invention exists in a surgical garment as previously discussed where the surgical garment has a pair of sleeves that extend from the arm openings.

[0013] Also, the surgical garment as described above may be configured so that the body portion is made of a fluid resistant material that does not permit strike through of contaminants to the operating table.

[0014] The present invention also provides for a method of preventing heat loss from a patient and a method of protecting an operating table from contaminants. The method includes covering the patient with a surgical garment that is worn by the patient that has at least one material that reduces heat transfer from the patient to the environment. Also included is the step of positioning the patient on the operating table along with the step of applying anesthesia to the patient. The surgical garment is opened such that the surgical garment covers at least a portion of the operating table and extends over the sides of the operating table and prevents contamination of the operating table during the surgical procedure.

### BRIEF DESCRIPTION OF THE DRAWINGS

[0015] FIG. 1 is a perspective view of an exemplary embodiment of a surgical garment in accordance with the

present invention. The surgical garment is shown as being worn by a patient awaiting surgery on a pre-op table.

[0016] FIG. 2 is a perspective view of an exemplary embodiment of a surgical garment in accordance with the present invention. The surgical garment is shown as being opened and laying across an operating table in order to protect the operating table from contaminants during surgery.

[0017] FIG. 3 is a perspective view of an exemplary embodiment of a surgical garment in accordance with the present invention. Here, the surgical garment is shown as being opened from the waist of the patient upward, and is shown protecting a portion of the operating table from contaminants during surgery.

[0018] FIG. 4 is a perspective view of an exemplary embodiment of a surgical garment in accordance with the present invention. Here, the surgical garment is shown being worn by a patient and being closed by a series of hook and loop type fastener sections.

[0019] FIG. 4A is a close up view of the exemplary embodiment of the surgical garment shown in FIG. 4.

[0020] FIG. 5 is a perspective view of an exemplary embodiment of a surgical garment in accordance with the present invention. Here, the surgical garment is closed by a series of snaps and is shown as being sleeveless and extending to a point above the knees of a patient.

[0021] FIG. 5A is a close up view of the exemplary embodiment of the surgical garment shown in FIG. 5. The view shows the attachment mechanism being a series of snaps.

[0022] FIG. 6 is a perspective view of an exemplary embodiment of a surgical garment in accordance with the present invention. Here, the surgical garment is shown as being capable of being opened in the front, and is shown as having a pair of sleeves, and a length extending to approximately the ankles of the patient.

[0023] FIG. 6A is a close up view of the exemplary embodiment of the surgical garment shown in FIG. 6. Here, the attachment mechanism is shown as being a strip of a hook and loop type fastener.

[0024] FIG. 7 is a perspective view of an exemplary embodiment of a surgical garment in accordance with the present invention. Here, the surgical garment is shown as being capable of being opened in the back, and has a pair of sleeves that extend to a point proximate to the patients elbows, and has a length that extends to approximately the ankles of the patient.

[0025] FIG. 7A is a close up view of the exemplary embodiment of the surgical garment shown in FIG. 7. Here, the attachment mechanism is shown as being a series of buttons.

[0026] FIG. 8 is a cross section view of a body portion of an exemplary embodiment of a surgical garment in accordance with the present invention. Here, the body portion is shown as being composed of three layers, e.g., spunbond, meltblown, spunbond polyolefin laminate.

#### DETAILED DESCRIPTION

[0027] Reference will now be made in detail to embodiments of the invention, one or more examples of which are

illustrated in the drawings. Each example is provided by way of explanation of the invention, and not meant as a limitation of the invention. For example, features illustrated or described as part of one embodiment can be used with another embodiment to yield still a third embodiment. It is intended that the present invention include these and other modifications and variations.

[0028] FIG. 1 shows a surgical garment 10 that is worn by a patient 12. The surgical garment 10 may be made of any material conventionally known in the art which is capable of retaining heat and therefore providing warmth to the patient 12. For instance, the surgical garment 10 may in certain exemplary embodiments of the present invention be made of polyolefin nonwovens, nylon, cotton, wool, reprocessed wool, rayon, film or plastic, acetate, and/or polyester. Additionally, other materials conventionally known in the art may be employed in the construction of the surgical garment 10.

[0029] The surgical garment 10 is designed to be worn by the patient 12 before the patient undergoes a surgical procedure. The surgical garment 10 therefore reduces the possibility of hypothermia and/or uncomfortable coldness as is common in operating room settings. The surgical garment 10 may be worn by the patient in a pre-op room and may also be worn by the patient 12 while lying on a pre-op table 14 awaiting surgery. The surgical garment 10 is wrapped around the patient 12 and covers a large percentage of the patient's 12 body. The surgical garment 10 is composed of a body portion 44. The body portion 44 is made of a first flap 16 and a second flap 18.

[0030] As shown in FIG. 7 the surgical garment 10 includes a body portion 44 that has a back section 26 that substantially covers the back 42 of the patient 12. As such, the back section 26 is configured to be worn on at least the back 42 of the patient 12. The first and second flaps 16 and 18 may therefore extend from the back section 26, or may be formed integrally with the back section 26. Referring back to FIG. 1, the body portion 44 is provided with a first sleeve 32 and a second sleeve 34 to substantially cover the arms of the patient 12. The first sleeve 32 may extend from the back section 26 (as shown in FIG. 7) and the first flap 16. Also, the second sleeve 34 may extend from the back section 26 (as shown in FIG. 7) and the second flap 18.

[0031] The first sleeve 32 and the second sleeve 34 may be made of the same material as the rest of the body portion 44, or may be made of a different type of material. Also, the length of the first sleeve 32 and the second sleeve 34 may be varied in other exemplary embodiments in the present invention. For instance, FIG. 4 shows an exemplary embodiment of the surgical garment 10 where the sleeves 32 and 34 extend to approximately the wrists of the patient 12. In contrast, FIG. 7 shows an exemplary embodiment of the surgical garment 10 where the first and second sleeves 32 and 34 extend to a point above the elbow of the patient 12. Therefore, it is to be understood that the present invention includes various configurations of the first sleeve 32 and the second sleeve 34 and is not limited to a particular length or shape of the first and second sleeves 32 and 34.

[0032] Referring to FIG. 1, it can be seen that the front 48 of the body portion 44 may extend to approximately the ankles of the patient 12. This length of extension helps to fully cover the legs of the patient 12 and prevent heat loss. However, it is to be understood that in other exemplary

embodiments of the present invention, the body portion 44 does not have to extend to the ankles of the patient 12. For instance, FIG. 5 shows an exemplary embodiment of the surgical garment 10 in which the body portion 44 extends to the thighs of the patient 12 and to a point above the knees of the patient 12. Also, FIG. 7 shows an exemplary embodiment of the surgical garment 10 in accordance with the present invention where the back 50 of the body portion 44 extends to approximately the calves of the patient 12. As such, it is to be understood that the present invention includes various embodiments of the surgical garment 10 where the length of the body portion 44 is varied so as to cover various parts of the legs of the patient 12. As such, the surgical garment 10 of the present invention is not limited to a specific length or area of coverage of the patient 12.

[0033] Referring back to FIG. 1, the first flap 16 and the second flap 18 are connected to one another by an attachment mechanism 30. The point of connection between the first flap 16 and the second flap 18 is labeled as being an opening section 46. The attachment mechanism 30 is located on at least the first flap 16 and/or the second flap 18. The attachment mechanism 30 is configured to releasably attach and detach the first and second flaps 16 and 18.

[0034] FIG. 2 shows the attachment mechanism 30 being detached so that the first flap 16 and second flap 18 may be removed from one another at the opening section 46 (as shown in FIG. 1) and removed from the front 20 of the patient 12. FIG. 2 shows the patient 12 being positioned on an operating table 28 with the surgical garment 10 disposed between at least a portion of the operating table 28 and the patient 12. Therefore, during surgery either before or after anesthesia is applied to the patient 12, the surgical garment 10 may be opened so that a desired area of the front 20 of the patient 12 is exposed for the commencement of a surgical procedure. The surgical garment 10 therefore acts as a protecting covering to the operating table 28 during a surgical procedure. Fluids and other contaminants resulting from surgery are prevented from contacting the operating table 28 due to the presence of the surgical garment 10. Once surgery is completed, the soiled surgical garment 10 may then be disposed of in order to facilitate an easier and faster method of cleanup after surgery.

[0035] As can be seen in FIG. 2, the back 50 of the body portion 44 and the second flap 18 defines a left arm opening 22. The second sleeve 34 extends from the left arm opening 22, and the left arm opening 22 allows for the left arm of the patient 12 to be inserted and removed from the second sleeve 34. Additionally, the back 50 of the body portion 44 and the first flap 16 define a right arm opening 24. Similarly, the right arm opening 24 allows for the right arm of the patient to be inserted into and removed from the first sleeve 32 (as shown in FIG. 1).

[0036] The body portion 44 is also provided with a left tab portion 52 and a right tab portion 54. The two tabs portions 52 and 54 are shown as being laid across the operating table 28 in FIG. 2, and may be made of the same or different material as the material that composes the body portion 44. The left and right tab portions 52 and 54 are shown in FIG. 4 as being connected to the front 48 of the body portion 44. Referring back to FIG. 2, the purpose of the left and right tab portions 52 and 54 is to allow for the surgical garment 10 to more evenly lie against the operating table 28. The left

and right tab portions 52 and 54 are located around the neck of the patient 12. Without their presence, it may be hard for the upper portion of the surgical garment 10 to lay against the operating table 28. It could be the case that the surgical garment 10 would "bunch up" around the neck and shoulders of the patient 12 due to the fact that this area of the surgical garment 10 is typically curved in order to accommodate the neck and shoulders of the patient 12. The left and right tab portions 52 and 54 therefore allow for an easier removal of the surgical garment 10 and a better fit of the surgical garment 10 on the operating table 28 in order to protect the operating table 28 from contaminants imparted during surgery. However, the surgical garment 10, in other exemplary embodiments, does not need to be provided with the tab portions 52 and 54.

[0037] FIG. 3 shows an exemplary embodiment of the surgical garment 10 in accordance with the present invention. Here, the surgical garment 10 has the body portion 44 extending to approximately the ankles of the patient 12. Additionally, a pair of slippers 56 may be worn by the patient 12 in order to prevent heat loss both before, during, and possibly after surgery. The surgical garment 10 in this instance may be worn by the patient 12 when the patient 12 is under going a surgical procedure that is localized to an area above the waist of the patient 12. The surgical garment 10 as shown in FIG. 3 is only configured to be opened above the waist of the patient 12, and is not configured to be opened below the waist of the patient 12. In such an instance, the surgical garment 10 may remain on the legs of the patient 12 during surgery and therefore help to prevent further heat loss from the patient 12. The surgical garment 10 is opened above the patient 12 and lays across the operating table 28 in order to protect this portion of the operating table 28 from contaminants during surgery.

[0038] The first sleeve 32 (not shown in FIG. 3) and the second sleeve 34 may be draped over the operating table 28 in order to provide for an even fit of the surgical garment 10 on the operating table 28. However, it is to be understood that in other exemplary embodiments of the present invention, that the sleeves 32 and 34 of the surgical garment 10 do not need to be laid over the edge of the operating table 28. Additionally, the surgical garment 10 is provided with the left and right tab portions 52 and 54 in order to better fit the open surgical garment 10 to the operating table 28. However, in other exemplary embodiments of the present invention, the surgical garment 10 is not provided with the left and right tab portions 52 and 54. Upon completion of the surgical procedure, the patient 12 may be removed from the surgical garment 10 and the surgical garment 10 may be disposed of as previously discussed. However, in other exemplary embodiments of the present invention, the patient 12 may remain in the surgical garment 10 for some time after completion of the surgical procedure in order to prevent heat loss and prevent any unnecessary trauma to the patient 12.

[0039] FIG. 4 shows an exemplary embodiment of the attachment mechanism 30 of the surgical garment 10. Here the attachment mechanism 30 is shown as being a series of hook and loop type fasteners 58. Such hook and loop type fasteners 58 are commonly known in the art, and various configurations of the hook and loop type fasteners 58 are possible in accordance with the present invention. The hook and loop type fasteners 58 may be carried on the first flap 16 and/or the second flap 18. Additionally, the hook and loop

type fasteners 58 may be incorporated into the material of the surgical garment 10, and do not need to be separate components that are carried by the first flap 16 and/or the second flap 18. The hook and loop type fasteners 58 are a series of evenly sized sections that extend down the opening section 46 in the body portion 44. Attachment of the hook and loop type fasteners 58 to one another cause the surgical garment 10 to be closed and retained on the user 12. Additionally, the opening section 46 is closed during attachment of the hook and loop type fasteners 58.

[0040] FIG. 4A shows a close up view of the hook and loop type fasteners 58 being in a disengaged arrangement. Here, the first flap 16 carries a pair of hook sections 64 of the hook and loop type fastener 58. The second flap 18 carries a pair of loop sections 66 of the hook and loop type fastener 58. However, it is to be understood that in other exemplary embodiments of the present invention, that one or more of the hook sections 64 may be placed on the second flap 18, and one or more of the loop sections 66 may be placed on the first flap 16. As such, the present invention includes various embodiments where the hook and loop type fastener 58 is employed in different configurations in order to provide for an attachment and detachment of the first flap 16 and the second flap 18.

[0041] Also, FIG. 4 shows the left tab portion 52 and the right tab portion 54 being connected to the second flap 18 and the first flap 16 respectively. This attachment may be affected by a hook and loop type fastener 58 in each instance. This type of arrangement allows for the left and right tab portions 52 and 54 to be removably connected to the flaps 18 and 16 during donning of the surgical garment 10 by the patient 12 and also allows for the opening of the surgical garment 10 during or shortly before surgery. However, it is to be understood that other means of engaging the left and right tab portions 52 and 54 are possible in accordance with the present invention, and the invention is not limited to the use of a hook and loop type fastener 58.

[0042] FIG. 6 shows an exemplary embodiment of the surgical garment 10 where the body portion 44 has an opening section 46 that extends from approximately the neck of the patient 12 to the waist of the patient 12. FIG. 6 therefore shows the patient 12 wearing the surgical garment 10 at a point before the conduction of surgical procedures. However, the present invention also envisions exemplary embodiments where the surgical garment 10 may be worn by the patient 12 as shown in FIG. 6 at a point after the surgical procedure has been conducted.

[0043] FIG. 6 shows an exemplary embodiment of the surgical garment 10 having the attachment mechanism 30 be a hook and loop type fastener 58 that is a continuous strip. The surgical garment 10 of FIG. 6 is open and shown as being worn by the patient 12 in FIG. 3. A close up view of the hook and loop type fastener 58 is shown in FIG. 6A. Here, the hook and loop type fastener 58 is composed of a loop section 66 that is a continuous strip on the second flap 18. Additionally, the hook section 64 of the hook and loop type fastener 58 is a continuous strip on the first flap 16. The hook and loop type fastener 58 may be attached by engagement of the hook section 64 and the loop section 66. Doing so will cause the first flap 16 to be retained on the second flap 18 as shown in FIG. 6. Additionally, the first and second flaps 16 and 18 may be disconnected from one another at the

opening section 46 upon disengagement of the hook section 64 and loop section 66 of the hook and loop type fastener 58. Although as shown as being located on the second flap 18 in FIG. 6A, the loop section 66 may be placed on the first flap 16, and the hook section 64 may be placed on the second flap 18 in other exemplary embodiments of the present invention. Additionally, the surgical garment 10 may include an exemplary embodiment where the hook and loop type fastener 58 extends from a portion of the body portion 44 proximate to the neck of the patient 12 down the front 48 of the body portion 44 to the end of the body portion 44 proximate to the ankles of the patient 12. Therefore, other configuration of the surgical garment 10 having the hook and loop type fastener 58 being a continuous strip are possible in accordance with the present invention. The exemplary embodiment shown in FIG. 6 is also shown in FIG. 3, although in FIG. 3 the surgical garment 10 is opened and is covering the operating table 28.

[0044] FIG. 5 shows another exemplary embodiment of the surgical garment 10 in accordance with the present invention. Here, the body portion 44 is sleeveless, and is not provided with a pair of sleeves as disclosed in other exemplary embodiments. Additionally, the surgical garment 10 only extends to the thighs of the patient 12. Such a surgical garment 10 may be employed in situations in which a high degree of heat retention is not desired, for instance when an adult is being prepared for surgery. However, it is also to be understood that the surgical garment 10 disclosed in FIG. 5 may be used when the patient 12 is an elderly person or an infant.

[0045] The attachment mechanism 30 disclosed in FIG. 5 is a series of snaps 62 that extend down the front 48 of the body portion 44. As shown in greater detail in FIG. 5A, the snaps 62 include a series of male sections 68 disposed on the first flap 16, and a series of corresponding female sections 70 disposed on the second flap 18. In other exemplary embodiments of the present invention, one or more of the female sections 70 may be disposed on the first flap 16, and one or more of the male sections 68 disposed on the second flap 18. The present invention therefore includes embodiments where all of the male sections 68 are disposed on one of the flaps 16 and 18, and embodiments where the male sections 68 are disposed on both the two flaps 16 and 18. The surgical garment 10 may be opened and closed by snapping the male section 68 into the female section 70 as conventional buttons of this type are well known in the art.

[0046] FIG. 7 discloses an exemplary embodiment of the surgical garment 10 where the back 50 of the body portion 44 is provided with an opening section 46. In this instance, the patient 12 may be placed on his or her front side, and the body portion 44 may be opened at the opening 46 to expose the back 42 of the patient 12 for a surgical procedure. Additionally, the surgical garment 10 may also be provided with an opening section 46 on the front 48 of the body portion 44 as disclosed in FIG. 4. Therefore, the surgical garment 10 may be provided with the ability to open at the front 48 and/or back 50 of the body portion 44. This would allow for the surgical garment 10 to be a universal type surgical garment 10 in which the surgical garment 10 may be employed irregardless of whether the procedure to be performed on the patient 12 is to be done on the front or the back 42 of the patient 12.

[0047] Referring again to FIG. 7, the attachment mechanism 30 disclosed is a series of buttons 74 that extend along the entire length of the body portion 44. The attachment mechanism 30 is shown in greater detail in FIG. 7A. Here, the buttons 74 are shown as being disposed upon the first flap 16. A series of corresponding slits 72 are carried on the second flap 18. The buttons 74 may engage the slits 72 and be retained on the second flap 18 as is commonly known in the art. Again, placement of the buttons 74 on the first flap 16 and the slits 72 on the second flap 18 may be varied such that some or all of the buttons 74 are on the first flap 16 and/or the second flap 18, and so that some or all of the slits 72 are carried on the first flap 16 and/or the second flap 18.

[0048] Additionally, other types of attachment mechanisms 30 are capable of being used in the surgical garment 10 of the present invention. For instance, the attachment mechanism 30 may be other types of buttons and hook and loop type fasteners from those disclosed herein. Additionally, the attachment mechanisms 30 may be snaps, zippers, tape and/or adhesive in other exemplary embodiments of the present invention. Additionally, the attachment mechanism 30 may be ties which are strings that may be tied together to effect closure. Also, combinations of the aforementioned attachment mechanisms 30 are capable of being employed, and the present invention is not limited to a specific type of attachment mechanism 30.

[0049] FIG. 8 shows a cross sectional view of an exemplary embodiment of the body portion 44 in accordance with the present invention. Here, the body portion 44 is shown as being composed of three layers. However, it is to be understood that in other exemplary embodiments of the present invention, the body portion 44 may be a single layer, a dual layer, or may be composed of layers that are greater than three in number. FIG. 8 is therefore an exemplary embodiment of the cross section of the body portion 44, and is not a limitation wherein the body portion 44 is limited to having only three layers.

[0050] As such, the body portion 44 may be made of any material and/or any combination of materials. The body portion 44 may be multi-layered or may be a single layer. In one exemplary embodiment of the present invention the body portion 44 is made of a spunbond, meltblown and spunbond layer configuration (SMS). The meltblown layer may be a series of meltblown fibers that are formed by extruding a molten thermoplastic material through a plurality of fine, usually circular dye capillaries as molten threads or filaments. These are extruded into converging high velocity, usually hot gas (for example, air) streams which attenuate the filaments of thermoplastic material to reduce their diameter, which may be to microfiber diameter. Thereafter, the meltblown fibers are carried by the high velocity gas stream and are deposited on a collecting surface to form a web of randomly dispersed meltblown fibers. Such a process is disclosed, for example, in U.S. Pat. No. 3,849,241 to Butin et al, the contents of which are incorporated herein by reference for all purposes in their entirety.

[0051] The spunbond layer may be composed of spunbond fibers which are small diameter fibers that are formed by extruding molten thermoplastic material such as filaments from a plurality of fine, usually circular capillaries of a spinneret with the diameter of the extruded fibers. The extruded fibers are then rapidly reduced. Examples of spun-

bond fibers may be found in U.S. Pat. No. 4,340,563 to Appel et al, U.S. Pat. No. 3,692,618 to Dorschner et al, U.S. Pat. No. 3,802,817 to Matsuki et al, U.S. Pat. No. 3,338,992 to Kinney, U.S. Pat. No. 3,341,394 to Kinney, U.S. Pat. No. 3,502,763 to Hartman, and U.S. Pat. No. 3,542,615 to Dobo et al. The foregoing patents are incorporated by reference herein in their entirety for all purposes. Spunbond fibers are generally not tacky when they are deposited on a collecting surface.

[0052] The body portion 44 may therefore be configured in an SMS configuration. However, the present invention is not limited to an SMS configuration of the body portion 44. The body portion 44 may partially prevent fluid from moving therethrough, or may be completely impervious to the transmission of fluid through the body portion 44. Additionally, the body portion 44 may be absorbent or may be non-absorbent in other exemplary embodiments of the present invention. As stated, the body portion 44 may be a single layer or may be several layers. The body portion 44 may be made from a number of materials, for instance, non-woven, polyolefin, polypropylene, or copolymer materials may be used in the construction of the body portion 44 in various embodiments of the present invention.

[0053] FIG. 8 shows an insulation layer 40 being located on one end of the body portion 44. The insulation layer 40 is the layer that contacts the skin of the patient 12. The insulation layer 40 may be composed of any conventionally known insulated material that is used in blankets or in other clothing. For instance, the insulation layer 40 may be composed of nylon, cotton, wool, reprocessed wool, rayon, acetate, and/or polyester. The insulation layer 40 is designed in order to retain heat generated by the patient 12 and keep this heat within the surgical garment 10 in order to prevent heat loss of the patient to the environment.

[0054] Affixed and adjacent to the insulation layer 40 is an absorbent layer 38. The purpose of the absorbent layer 38 is to absorb fluids and other contaminants that fall onto the body portion 44 during the surgical procedure. The absorbent layer 38 may be made of any conventionally known material in the art capable of absorbing fluid and for at least a short amount of time retaining the fluid therein. For instance, the absorbent layer may be composed of pulp fibers, a woven or nonwoven web, a sponge, or other materials such as cotton, wool, nylon, and/or rayon.

[0055] Affixed and adjacent to the absorbent layer 38 is a fluid impervious layer 36. The fluid impervious layer 36 contacts the operating table 28. The fluid impervious layer 36 is designed in order to prevent the transfer of fluid from the absorbent layer 38 to the operating table 28. The fluid impervious layer 36 may therefore be any conventional material that prevents the strike through of fluid. For instance, the fluid impervious layer 36 may be certain types of plastic. Although shown as being composed of three layers, the body portion 44 can be a single layer that exhibits some or all of the aforementioned properties attributed to the insulation 40, the absorbent layer 38, and the fluid impervious layer 36. For instance, in other exemplary embodiments of the present invention, the body portion 44 may be comprised of only a single layer of cotton. Additionally, the surgical garment 10 may be disposable, and may be disposed of following the surgical procedure.

[0056] Although being described as not allowing the strike through of fluid to the operating table 28, in other exemplary

embodiments of the present invention the surgical garment **10** may be constructed such that strike through of contaminants is permitted to the operating table **28**, but at least some of the contaminants are absorbed by the surgical garment **10**. On the other hand in other exemplary embodiments of the present invention, the surgical garment **10** does not absorb contaminants but merely prevents them from being transferred to the operating table **28**. However, the surgical garment **10** may be in other exemplary embodiments configured for either allowing or not allowing strike through of contaminants to the operating table **28**. As used in the claims, the term fluid resistant means the material or article prevents some or all strike through of fluid therethrough.

[**0057**] The surgical garment **10** of the present invention may therefore prevent heat loss from the patient **12** and also protect the operating table **28** from contaminants. The patient **12** would first be covered with the surgical garment **10** that has at least one material therein that prevents heat loss from the patient **12** to the environment. The patient **12** would then be transported into an operating room and placed on the operating table **28**. At this point, anesthesia may be applied to the patient in order to render the patient unconscious for the conduction of a surgical procedure. Next, the surgical garment **10** may be opened by disengaging the attachment mechanism **30** and positioned so as to cover at least a portion of the operating table **28**. This coverage would prevent contamination of the operating table **28** during the surgical procedure. Once the surgical procedure is completed, the patient **12** may be removed from the surgical garment **10**, and the surgical garment **10** may be discarded.

[**0058**] The surgical garment **10** may therefore serve as a cover up or may be worn like a full body "comforter" that is wrapped around the patient **12** while in pre-op. The material comprising the surgical garment **10** may be a material that is disposable and may be a material that is soft enough to be comfortable to the patient **12**. Also, the material may be heavy enough in basis weight to provide for warmth to the patient **12** and also to provide adequate coverage for any modesty concerns.

[**0059**] The patient **12** may remain in the surgical garment **10** until anesthesia is applied at which point the patient **12** is removed from the surgical garment **10**. However, it is to be understood that in other exemplary embodiments of the present invention, that the patient **12** may remain in the surgical garment **10** both during, before, and after the application of anesthesia.

What is claimed is:

1. A surgical garment for a patient comprising:

- a back section configured to be worn on at least the back of the patient, said back section being fluid resistant;
- a first flap extending from an end of said back section and configured to be worn on at least the front side of the patient, said first flap and said back section defining a right arm opening;
- a second flap extending from said back section on an end opposite from said first flap, said second flap configured to be worn on at least the front side of the patient, said second flap and said back section defining a left arm opening;

an attachment mechanism located on at least said first flap or said second flap, said attachment mechanism configured to releaseably attach and detach said first and second flaps, detachment of said attachment mechanism allowing for said first and second flaps to be removed from the front side of the patient; and

wherein during detachment said back section, said first flap, and said second flap are configured to at least partially cover an operating table to protect the table from contact with contaminants, said first and second flaps configured for extending over the sides of the operating table.

2. The surgical garment of claim 1, wherein said back section, said first flap, and said second flap being at least partially made of a material that reduces heat transfer from the patient to the environment.

3. The surgical garment of claim 1, wherein said back section, said first flap, and said second flap extend from the neck of the patient to the feet of the patient.

4. The surgical garment of claim 1, wherein said attachment mechanism is selected from the group consisting of buttons, snaps, zippers, hook and loop type fasteners, tape, and adhesive.

5. The surgical garment of claim 1, further comprising:

a first sleeve extending from said back section and said first flap at said right arm opening; and

a second sleeve extending from said back section and said second flap at said left arm opening.

6. The surgical garment of claim 1, wherein said back section, said first flap, and said second flap have at least one layer that does not permit any strike through of contaminants to the operating table.

7. The surgical garment of claim 1, wherein said back section, said first flap, and said second flap have at least one layer that is fluid absorbent.

8. The surgical garment of claim 1, wherein said back section, said first flap, and said second flap have at least one layer that is not fluid absorbent.

9. The surgical garment of claim 1, wherein:

said first flap has a first tab portion; and

said second flap has a second tab portion.

10. A surgical garment for a patient comprising:

a body portion extending over at least part of the back and at least part of the front of the patient, said body portion having at least one opening section, said body portion having a pair of arm openings for accommodating the arms of the user, said body portion being fluid resistant and being made of a material that reduces heat transfer from the patient to the environment;

an attachment mechanism carried by said body portion, said attachment mechanism configured to releaseably attach and detach said body portion such that said opening section is closed and opened; and

wherein during detachment of said attachment mechanism, said body portion is configured to at least partially cover an operating table to protect the table from contaminants, said body portion being configured for extending over the sides of the operating table.

**11.** The surgical garment of claim 10, wherein said body portion has one of said opening sections at the front of said body portion and has another of said opening sections at the back of said body portion.

**12.** The surgical garment of claim 10, wherein said body portion extends from the neck of the patient to the feet of the patient.

**13.** The surgical garment of claim 10, wherein said attachment mechanism is selected from the group consisting of buttons, ties, snaps, zippers, hook and loop type fasteners, tape, and adhesive.

**14.** The surgical garment of claim 10, further comprising:

a first sleeve extending from said body portion at one of said arm openings; and

a second sleeve extending from said body portion at the other of said arm openings.

**15.** The surgical garment of claim 10, wherein said body portion is made of a fluid impervious material that does not permit strike through of any contaminants to the operating table.

**16.** The surgical garment of claim 10, wherein said body portion having a right tab portion and a left tab portion.

**17.** A method of preventing heat loss from a patient and protecting an operating table from contaminants, comprising the steps of:

covering the patient with a surgical garment that is worn by the patient that has at least one material therein that reduces heat transfer from the patient to the environment, and has at least one material therein that is fluid resistant;

positioning the patient on the operating table;

applying anesthesia to the patient;

opening said surgical garment such that said surgical garment covers at least a portion of the operating table and prevents contamination of the operating table during a surgical procedure and such that said surgical garment extends over the sides of the operating table.

**18.** The method of claim 17, wherein said surgical garment extends from the neck of the patient to the feet of the patient.

**19.** The method of claim 17, wherein said surgical garment has an attachment mechanism that is used to selec-

tively open and close an opening in the surgical garment to allow for said step of opening said surgical garment, said attachment mechanism is selected from the group consisting of buttons, snaps, zippers, ties, hook and loop type fasteners, tape, and adhesive.

**20.** The method of claim 17, wherein said surgical garment has a pair of sleeves extending therefrom.

**21.** The method of claim 17, wherein said surgical garment is made of a fluid impervious material that does not permit strike through of any contaminants to the operating table.

**22.** The method of claim 17, wherein said surgical garment is made of a fluid absorbing material.

**23.** The method of claim 17, wherein said surgical garment is made of a material that is not fluid absorbent.

**24.** A surgical garment for use in preventing heat loss from a patient and for protecting an operating table from contamination, comprising:

a body portion extending over at least part of the back and at least part of the front of the patient, said body portion having at least one opening section extending from a first end to a second end of said body portion, said body portion having a pair of arm openings for accommodating the arms of the user, said first end being located at the neck of the patient and said second end being located at the feet of the patient when said body portion is placed on the patient, said body portion being at least partially made of a material that reduces heat transfer from the patient to the environment, said body portion being made of a fluid resistant material that does not permit strike through of contaminants;

an attachment mechanism carried by said body portion, said attachment mechanism configured to releasably attach and detach said body portion such that said opening section is closed and opened; and

wherein during detachment of said attachment mechanism, said body portion is configured to at least partially cover the operating table to protect the table from contaminants.

\* \* \* \* \*