



- (51) International Patent Classification:
E01H 5/04 (2006.01)
- (21) International Application Number:
PCT/US2016/015111
- (22) International Filing Date:
27 January 2016 (27.01.2016)
- (25) Filing Language: English
- (26) Publication Language: English
- (30) Priority Data:
62/108,116 27 January 2015 (27.01.2015) US
- (71) Applicant: **MTD PRODUCTS INC** [US/US]; 5903
Grafton Road, Valley City, Ohio 44280 (US).
- (72) Inventors: **SCHAEDLER, Axel**; 27171 Cook Road,
Olmsted Township, Ohio 44138 (US). **BUCHANAN,
Peter**; 150 Overbrook Road, Elyria, Ohio 44035 (US).
- (74) Agent: **RESSER, David, A.**; Wegman, Hessler & Vander-
burg, 6055 Rockside Woods Boulevard, Suite 200, Cleve-
land, Ohio 44131 (US).
- (81) Designated States (unless otherwise indicated, for every
kind of national protection available): AE, AG, AL, AM,
AO, AT, AU, AZ, BA, BB, BG, BH, BN, BR, BW, BY,

BZ, CA, CH, CL, CN, CO, CR, CU, CZ, DE, DK, DM,
DO, DZ, EC, EE, EG, ES, FI, GB, GD, GE, GH, GM, GT,
HN, HR, HU, ID, IL, IN, IR, IS, JP, KE, KG, KN, KP, KR,
KZ, LA, LC, LK, LR, LS, LU, LY, MA, MD, ME, MG,
MK, MN, MW, MX, MY, MZ, NA, NG, NI, NO, NZ, OM,
PA, PE, PG, PH, PL, PT, QA, RO, RS, RU, RW, SA, SC,
SD, SE, SG, SK, SL, SM, ST, SV, SY, TH, TJ, TM, TN,
TR, TT, TZ, UA, UG, US, UZ, VC, VN, ZA, ZM, ZW.

- (84) Designated States (unless otherwise indicated, for every
kind of regional protection available): ARIPO (BW, GH,
GM, KE, LR, LS, MW, MZ, NA, RW, SD, SL, ST, SZ,
TZ, UG, ZM, ZW), Eurasian (AM, AZ, BY, KG, KZ, RU,
TJ, TM), European (AL, AT, BE, BG, CH, CY, CZ, DE,
DK, EE, ES, FI, FR, GB, GR, HR, HU, IE, IS, IT, LT, LU,
LV, MC, MK, MT, NL, NO, PL, PT, RO, RS, SE, SI, SK,
SM, TR), OAPI (BF, BJ, CF, CG, CI, CM, GA, GN, GQ,
GW, KM, ML, MR, NE, SN, TD, TG).

Published:

- with international search report (Art. 21(3))
- before the expiration of the time limit for amending the
claims and to be republished in the event of receipt of
amendments (Rule 48.2(h))

(54) Title: SNOW THROWER IMPELLER

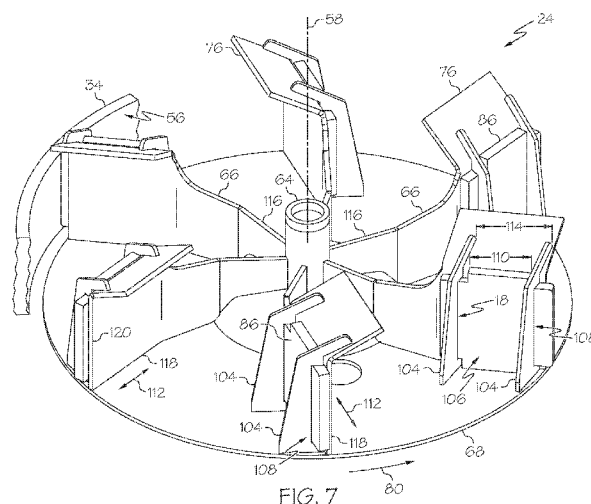

(57) Abstract: Provided is a snow thrower impeller assembly (24) that defines a mounting slot (84) for a wiper (70). The wiper includes a wiper portion (86) that slides into the mounting slot to mount the wiper to the impeller (54). The wiper contacts an interior wall (56) of an associated impeller housing during rotational operation of the impeller in order to limit a gap (74) between an impeller blade (66) and the interior wall. The wiper can move radially inward and outward to remain in contact with the interior wall without input from the operator. Another embodiment of the impeller assembly includes impeller blades with a first portion (116) and a second portion (118). The second portion extends at a non-zero angle from the first blade portion of the impeller blade. Methods of improving the efficiency of the snow thrower are also provided.

WO 2016/123211 A1

SNOW THROWER IMPELLER

CROSS REFERENCE TO RELATED APPLICATION

[0001] This application claims the priority benefit of U.S. Provisional Patent Application Serial No. 62/108,116 filed January 27, 2015.

BACKGROUND

1. Field of the Disclosure

[0002] This application relates generally to snow throwing power equipment, and more specifically to snow throwing power equipment including at least two stages, the final stage including an impeller with wipers.

2. Description of Related Art

[0003] Currently available powered snow throwers are generally provided with mechanisms configured to throw quantities of snow, ice, water, etc. after the quantities enter a housing at the front of the snow thrower. The mechanisms often include impellers located within an impeller housing. The impellers and the impeller housings are typically constructed of metal, and a gap is designed to exist between the impeller and the impeller housing to prevent contact between the two structures such as U.S. Patent No. 7,121,021. This gap allows snow, ice, and water to accumulate in the gap, decreasing the efficiency of the impeller.

[0004] Other snow throwers or material movers can include linear impeller blades having wipers attached to the impeller blades to lessen the accumulating material between the impeller and the impeller housing such as U.S. Patent No. 7,597,219. However, the wipers are fixed relative to the impeller blades and cannot account for imperfections in the impeller housing, wear on the wipers, etc. Accordingly, improvements to snow thrower impellers are desired.

SUMMARY

[0005] The following presents a simplified summary in order to provide a basic understanding of some example aspects of the disclosure. This summary is not an extensive overview. Moreover, this summary is not intended to identify critical elements of the disclosure nor delineate the scope of the disclosure. The sole purpose

of the summary is to present some concepts in simplified form as a prelude to the more detailed description that is presented later.

[0006] According to one aspect, the subject application involves an impeller assembly. The impeller assembly includes an impeller located within an associated impeller housing. The associated impeller housing defines an interior wall. The impeller includes a central axis of rotation and an outer circumference. The impeller defines a mounting slot. The impeller includes a hub located about the central axis of rotation and an impeller blade connected to the hub. The impeller blade extends from the hub toward the outer circumference. The impeller assembly also includes a wiper mounted adjacent the impeller blade. The wiper includes a wiper portion that slides into the mounting slot to mount the wiper to the impeller. The wiper contacts the interior wall of the associated impeller housing during rotational operation of the impeller in order to limit a gap between the impeller blade and the interior wall.

[0007] According to another aspect, the subject application involves an impeller assembly including an impeller located within an associated impeller housing. The associated impeller housing defines an interior wall. The impeller includes a central axis of rotation and an outer circumference. The impeller also includes a hub located about the central axis of rotation. The impeller further includes an impeller blade connected to the hub. The impeller blade includes a first blade portion and a second blade portion. The impeller blade extends from the hub toward the outer circumference. The second blade portion of the impeller blade extends at a non-zero angle from the first blade portion of the impeller blade.

[0008] According to another aspect, the subject application involves a method of improving an efficiency of a snow thrower impeller. The method includes the step of providing a multiple-stage snow thrower comprising an impeller assembly. The impeller assembly includes an impeller housing that defines an interior wall. The impeller assembly also includes an impeller located within the impeller housing. The impeller includes a central axis of rotation and an outer circumference, and the impeller defines a mounting slot. The impeller includes a hub located about the central axis of rotation and an impeller blade connected to the hub. The impeller blade extends from the hub toward the outer circumference. The impeller assembly also includes a wiper mounted adjacent the impeller blade. The wiper includes a wiper portion, and the wiper is mounted without the use of fasteners or tools. The

wiper contacts the interior wall of the impeller assembly during rotational operation of the impeller in order to limit a gap between the impeller blade and the interior wall. The method also includes the step of inserting the wiper into the mounting slot by hand and without the use of tools. The method further includes the step of operating the impeller by providing a rotational force to the impeller, wherein the wiper maintains contact with the interior wall during impeller rotation.

BRIEF DESCRIPTION OF THE DRAWINGS

[0009] The foregoing and other aspects of the present disclosure will become apparent to those skilled in the art to which the present disclosure relates upon reading the following description with reference to the accompanying drawings, in which:

[0010] FIG. 1 is a perspective view of a portion of an example snow thrower according to an aspect of the present disclosure;

[0011] FIG. 2 is an elevation side view of the portion of the snow thrower of FIG. 1 including an impeller assembly;

[0012] FIG. 3 is an elevation front view of the portion of the snow thrower of FIG. 1;

[0013] FIG. 4 is a top view of the impeller assembly of FIG. 2;

[0014] FIG. 5 is a side view of the impeller assembly of FIG. 2;

[0015] FIG. 6 is a perspective view of the impeller assembly of FIG. 2 showing a number of wipers in an outward-most position;

[0016] FIG. 7 is a perspective view of a second embodiment of an impeller assembly showing a second blade portion swept toward a direction of rotation of the impeller assembly;

[0017] FIG. 8 is similar to FIG. 7 showing the second blade portion swept away from a direction of rotation of the impeller assembly;

[0018] FIG. 9 is a perspective view of a wiper used on an impeller assembly of FIG. 1;

[0019] FIG. 10 shows deformation of a wiper by hand in order to mount the wiper to an impeller blade;

[0020] FIG. 11 is a detail view of the impeller assembly of FIG. 7 showing the wiper in a radially outward-most position;

[0021] FIG. 12 is a perspective view of a third embodiment of an impeller assembly showing four impeller blades and a wiper woven into each blade;

[0022] FIG. 13 is similar to FIG. 12 showing an impeller with three impeller blades;

[0023] FIG. 14 is a perspective view an example impeller blade from the impeller assembly of FIG. 12 or FIG. 13; and

[0024] FIG. 15 is a perspective view of an example wiper from the impeller assembly of FIG. 12 or FIG. 13.

DETAILED DESCRIPTION

[0025] Example embodiments that incorporate one or more aspects of the present disclosure are described and illustrated in the drawings. These illustrated examples are not intended to be a limitation on the present disclosure. For example, one or more aspects of the present disclosure can be utilized in other embodiments and even other types of devices. Moreover, certain terminology is used herein for convenience only and is not to be taken as a limitation on the present disclosure. Still further, in the drawings, the same reference numerals are employed for designating the same elements.

[0026] FIG. 1 shows a perspective view of a front portion of a powered snow thrower 20 including an impeller assembly 24 (best seen in FIG. 2) according to at least one aspect of the present disclosure. It should be understood by one of ordinary skill in the art that the snow thrower 20 may alternatively include a power supply such as a cord to receive electrical power, an internal combustion engine, a rechargeable battery, or any other commonly known power supplies. The snow thrower 20 can also include a pair of graspable handles (not shown) attached to the power supply that can be used by an operator to control the direction and movement of the snow thrower 20. The snow thrower 20 also includes tracks or a pair of wheels (not shown) attached to the power supply for allowing the snow thrower to roll along the ground while removing accumulated snow.

[0027] The snow thrower 20 is configured to remove piled-up snow and propels, or throws the snow from a chute 26 to a different location. The chute 26 is operatively connected to a housing 28 into which snow, ice, etc. enters the snow thrower 20 as the snow thrower 20 moves in a forward direction (represented by arrow 30). For the remainder of the disclosure, the snow thrower 20 will be shown

and discussed in the form of a multi-stage snow thrower having a first stage auger device driven on a shaft substantially perpendicular to the direction of travel of the snow thrower 20, a second stage auger device driven on a shaft substantially parallel with the forward direction 30 of the snow thrower 20, and a third stage impeller device. It is to be understood that the described impeller assembly 24 can also be used on snow throwers 20 having two stages, four stages, etc., with the final stage being the impeller assembly 24. Other examples of the snow thrower 20 can include an accelerator (not shown) that moves snow into the impeller housing 34.

[0028] As shown in FIGS. 1 and 2, the housing 28 is a generally semi-cylindrical, or C-shaped casing including an impeller housing 34 extending rearwardly from the central C-shaped portion, wherein the housing 28 is longitudinally oriented in a transverse direction relative to the forward direction 30 of movement of the snow thrower 20. The housing 28 includes an opening 36 into which snow enters the housing 28 and an outlet aperture 38 through which the snow is forced to exit the housing 28 into the impeller housing 34.

[0029] Turning to FIG. 2, in one example, a distal end of a longitudinal drive shaft 40 is connected to the power supply (not shown) and the opposing end of the longitudinal drive shaft 40 is operatively connected to a gear assembly 44 that is positioned within the housing 28.

[0030] The snow thrower 20 includes at least two augers 46, wherein at least one auger 46 is attached to each portion of a lateral drive shaft 48 extending from the gear assembly 44, as shown in FIGS. 1-4. In the illustrated exemplary embodiment, one (1) auger 46 is positioned on each of two portions of the lateral drive shaft 48 extending from the gear assembly 44. It should be understood by one of ordinary skill in the art that although the illustrated embodiment of a first stage assembly 50 includes only two augers 46, the first stage assembly 50 can include any number of augers 46 positioned adjacent to each side of the gear assembly 44 on the lateral drive shaft 48. The augers 46 can be removably connected to the longitudinal and lateral drive shafts 40, 48 by way of a connecting mechanism such as a nut-and-bolt, cotter pin, or the like. The augers 46 are configured to move snow axially along the lateral drive shaft 48, wherein the augers 46 located on opposing portions of the lateral drive shaft 48 relative to the gear assembly 44 are configured to move snow in an opposing manner relative to the augers 46 on the opposing portion of the lateral drive shaft 48. As such, the augers 46 are configured to move snow, ice and other

material toward the center of the housing 28, or toward the gear assembly 44 that is positioned at or near the center of the housing 28.

[0031] It should be understood by one of ordinary skill in the art that the augers 46 can be configured in a corkscrew or spiral shape or orientation relative to the drive shaft 40, 48 to which they are attached such that rotation of the augers 46 push snow along the axis of rotation of the respective drive shaft. For example, the augers 46 are configured to rotate and push or transport the snow in the direction from the side walls of the housing 28 toward the centrally-located gear assembly 44 and toward the impeller housing 34.

[0032] The snow thrower 20 includes the rotatable impeller assembly 24 operatively connected to the longitudinal drive shaft 40. The impeller assembly 24 includes an impeller 54 located within an impeller housing 34 which defines an interior wall 56, as shown in FIGS. 1-2 and 4. The impeller 54 is located on the longitudinal drive shaft 40 between the auger 46 and the power supply (not shown). The impeller 54 is configured to receive the snow from the auger 46, and through rotation of the impeller 54 about the longitudinal drive shaft 40 at a sufficient speed, the snow is expelled or centrifugally thrown through the chute 26 and away from the snow thrower 20. In one example, the impeller assembly 24 is removably attached to the longitudinal drive shaft 40 such that the impeller assembly 24 can be removed and replaced. The impeller assembly 24 can be attached to the longitudinal drive shaft 40 with any attachment mechanism such as nut-and-bolt, cotter pin, or the like.

[0033] In one example, the longitudinal drive shaft 40 is powered by the power supply such that the longitudinal drive shaft rotates between about 50 to about 1500 RPM. In one example, the impeller assembly 24 and the augers 46 are operatively connected to the longitudinal drive shaft 40 such that the impeller assembly 24 and the augers 46 rotate at substantially the same rotational velocity as the longitudinal drive shaft 40.

[0034] As shown in FIGS. 2 and 4, the impeller 54 includes a central axis of rotation (represented by point and/or line 58) and an outer circumference 60. The impeller 54 also includes a hub 64 located about the central axis of rotation 58. The hub 64 can provide a mounting point for the impeller 54 to be mounted to the longitudinal drive shaft 40. In one example, the impeller 54 is attached to the longitudinal drive shaft 40 by sliding the hub 64 over the outer surface of the

longitudinal drive shaft 40 and securing the impeller 54 to the drive shaft 40 by way of an attachment mechanism such as a nut-and-bolt, a cotter pin, or the like.

[0035] Turning to FIG. 4, the impeller 54 also includes an impeller blade 66 connected to the hub 64, and the impeller blade 66 extends from the hub 64 toward the outer circumference 60. In many cases, the impeller 54 includes a plurality of impeller blades 66 that extend radially outwardly from the hub 64. Each of the figures shows an impeller 54 including six (6) impeller blades, however, any number of impeller blades 66 can be included, including, but not limited to three, four, or five. In some cases, a greater number of impeller blades 66 (e.g., six), can lead to greater efficiencies, as snow and ice will spend less average time in the impeller housing 34.

[0036] While not required, the impeller 54 can also include a back plate 68. The hub 64 can be attached to the back plate 68 and located about the central axis of rotation 58. In the examples of the impeller 54 including the back plate 68, the impeller blade 66 can be connected to the hub 64 indirectly through the back plate 68 while not contacting the hub 64 directly. However, certain designs may include the impeller blades 66 directly connected to the hub 64 even when there is a back plate 68. In the examples with the back plate 68, the impeller blades 66 can extend from an interior location of the back plate 68 toward the outer circumference of the impeller 54 without contacting the hub 64.

[0037] The impeller assembly 24 also includes a wiper 70 mounted adjacent the impeller blade 66. In one example, the wiper 70 is composed of a flexible, resilient material, such as a rubber compound. For example, the wiper 70 can be composed of a rubber material including a fabric layer sandwiched within the rubber compound. The fabric layer can serve as reinforcement for the wiper structure. Any number of other flexible, resilient materials can be used to form the wiper 70.

[0038] Turning to FIG. 10, regardless of the material used to form the wiper 70, one example of the wiper includes a wiper that can be deformed from an original shape upon application of pressure from an operator's hand and return to the original shape upon removal of the application of pressure from the operator's hand. This enables the wiper 70 to slide into a mounting slot which will be described below to mount the wiper 70 to the impeller blade 66. As such, the wiper 70 can be configured to be mounted to the impeller blade 66 without the use of fasteners or tools; an operator can simply squeeze the wiper 70 to deform it, and then release the

squeeze force to enable the wiper 70 to return to its original shape and slide into the mounting slot.

[0039] The wiper 70 contacts the interior wall 56 of the impeller housing 34 during rotational operation of the impeller assembly 24 in order to limit and/or eliminate a gap 74 between the impeller blade 66 and the interior wall 56. Reduction and/or elimination of the gap 74 can lead to several benefits. For example, minimization of the gap 74 can lessen and/or eliminate quantities of snow, ice, etc. from accumulating in the annular space created by the gap 74, thereby reducing and/or eliminating recirculation of the material to be thrown by the snow thrower 20. This leads to greater efficiency of the snow thrower 20. Additionally, reduction and/or elimination of the gap 74 can lead to increased material throw distances for the snow thrower 20.

[0040] The impeller 54 can further include upper blade extensions 76 attached to the impeller blades 66. The upper blade extensions 76 can extend away from a top edge 78 of the impeller blade 66. The upper blade extensions 76 can generally extend axially away from the impeller blades 66, toward a direction of rotation 80, or a combination of these two directions. Inclusion of the upper blade extensions 76 can prevent snow, ice, water, etc. from leaving the impeller housing 34 through the outlet aperture 38 and returning to the housing 28 by acting as a rotating barrier to help keep the snow, ice, water, etc. within the impeller housing 34 prior to being thrown into the chute 26. In other words, the upper blade extensions 76 can act as “scoops” or “spoons” that help maintain the snow, ice, etc. in a path moving from the housing 28 to the chute 26. Additionally, the upper blade extensions 76 can also act as force concentration points which break-up larger chunks of snow and/or ice accumulations as the impeller rotates.

[0041] The impeller 54 defines a mounting slot 84, and the wiper 70 includes a wiper portion 86 that slides into the mounting slot 84 to mount the wiper 70 adjacent to the impeller blade 66. In one embodiment as shown in FIGS. 4-6, the upper blade extension 76 defines an upper mounting slot 88 (which is one example of the mounting slot 84) on a leading face side 90 of the impeller blade 66. The upper mounting slot 88 is oriented radially, or in a substantially radial orientation. The upper mounting slot 88 includes an upper mounting slot length 94. In some examples, the back plate 68 defines a lower mounting slot 96 generally opposing the upper mounting slot 88 defined by the upper blade extension 76. The lower mounting slot

96 includes a lower mounting slot length 98, which can be substantially equal to the upper mounting slot length 94. In this embodiment, the wiper portion 86 includes a radial section that is oriented radially, and the wiper portion 86 slides into the radial mounting slot 84 to mount the wiper 70 adjacent to the impeller blade 66. In this embodiment, the wiper 70 is located on the leading face side 90 of the impeller blade 66, and can be supported by the impeller blade 66 as it rotates and remains in contact with (or “wipes”) the interior wall 56 of the impeller housing 34. In this embodiment, the wiper 70 can be the same width or substantially the same width as the impeller blade 66 as measured in the axial direction.

[0042] In another embodiment as shown in FIGS. 7 and 8, the impeller 54 can also include a plurality of retainer plates 104 located on a trailing side 106 of the impeller blade 66. The retainer plates 104 can extend from the trailing side 106 of the impeller blade 66 to the back plate 68. The retainer plates 104 define a rear mounting slot 108 (which is one example of the mounting slot 84). The rear mounting slot 108 is oriented axially, or in a substantially axial orientation. In this embodiment, the wiper portion 86 is oriented axially, and the wiper portion 86 slides into the axially oriented rear mounting slot 108 to mount the wiper 70 adjacent to the impeller blade 66.

[0043] Returning to FIG. 10, the figure represents an operator’s hand applying a squeeze force to the wiper 70 to reduce the axial dimension in order to insert the wiper 70 into mounting slots 84 which will be oriented radially for the first embodiment. It is to be understood that the squeeze force will be applied in the transverse direction to mount the wiper 70 in the second embodiment that includes mounting slots 84 that are oriented axially.

[0044] In each of the above described embodiments, the construction of the impeller 54 and the wiper 70 enable the wiper 70 to move in a generally radial direction away from the hub 64 in order to maintain contact with the interior wall 56 of the impeller housing 34.

[0045] For example, in the first embodiment as shown in FIGS. 4-6, the upper mounting slot 88 includes an upper mounting slot length 94, and the wiper portion 86 includes a first wiper length 110. The upper mounting slot length 94 is greater than the first wiper length 110. Similarly, the lower mounting slot 96 includes a lower mounting slot length 98 that is greater than the first wiper length 110. The greater lengths of the mounting slots 94, 98 enable the wiper 70 to move in a

generally radial direction (represented by arrow 112) away from the hub 64 in order to maintain contact with the interior wall 56 of the impeller housing 34 while remaining mounted to the impeller blade 66. With the ability of the wiper 70 to move in the radial direction 112, centrifugal force created during rotation of the impeller 54 during normal operation of the snow thrower 20 will urge the wiper 70 radially outward until the wiper 70 contacts the interior wall 56 of the impeller housing 34.

[0046] In the second embodiment as shown in FIGS. 7-8, one of the retainer plates 104 is mounted a distance of a mounting length 114 from the other retainer plate 104, and the mounting length 114 is greater than the first wiper length 110. This difference in lengths 114, 110 enables the wiper 70 to move in a generally radial direction 112 away from the hub 64 in order to maintain contact with the interior wall 56.

[0047] FIGS. 4-6 show the first embodiment with the wiper 70 in the radially inward-most position. FIG. 11 shows the first embodiment with the wiper 70 in the radially outward-most position. FIG. 7 shows the second embodiment with the wiper 70 in the radially outward-most position while FIG. 8 shows the second embodiment in the radially inward-most position. Of course, the wiper 70 and impeller 54 can operate properly at any of the infinite wiper positions along the continuum between the inward-most and outward-most radial positions.

[0048] Enabling the wiper 70 to move radially can benefit the impeller 54 and the snow thrower 20 in multiple ways. In one example, rotation of the impeller 54 during normal operation may wear away an amount of the wiper 70 at the point of contact with the interior wall 56 of the impeller housing 34. As the wiper 70 wears, contact with the interior wall 56 can be maintained as the wiper 70 simply moves radially outward to compensate for the worn away wiper material.

[0049] In another example, the wiper 70 is not statically fixed to the impeller blade 66, and can thus move radially to contact the interior wall 56, regardless of the distance between the hub 64 and the interior wall 56. This enables the wiper 70 to automatically move without requiring an operator to manually move the wiper 70.

[0050] In yet another example, the interior wall 56 of the impeller housing 34 may include manufacturing imperfections such that the cross-section of the interior wall 56 is not perfectly circular. Even with potential inconsistencies in the radius of the interior wall 56, the wiper 70 will move radially out and radially in to maintain

contact with the interior wall 56 as the impeller 54 rotates. This constant contact helps ensure that the previously described benefits of the wipers 70 are maintained throughout the entire arc of rotation of the impeller 54.

[0051] In still yet another example, one step during assembly of the snow thrower 20, can include passing the impeller assembly 24 through the opening 36 from the housing 28 into the impeller housing 34 where the impeller assembly 24 can then be secured to the drive shaft 40. In some of those instances, the opening 36 can be of a smaller diameter than the diameter of the interior wall 56 of the impeller housing 34. However, the intent of the wipers 70 is to be in a position of the wider interior wall diameter to contact the interior wall 56. This would normally create a physical interference, preventing the step of passing the impeller assembly 24 through the opening 36. However, as the wipers 70 can be moved radially, the assembly step can include an operator moving the wipers 70 radially inward such that the diameter of the impeller 54 with the wipers 70 is less than the diameter of the opening 36. This eases the assembly process of the snow thrower 20. Then, during normal operation, centrifugal force will move the wipers to increase the effective diameter of the impeller 54 such that the wipers 70 contact the interior wall 56 of the impeller housing 34 during normal operation.

[0052] It is to be understood that additional mass within the wipers 70 can accentuate the effect of the centrifugal force pushing the wipers 70 into contact with the interior wall 56. As such, the wiper 70 can have various appendages or add-ons that increase the weight to improve the effectiveness of the wiper 70 contact with the interior wall 56. In one example, the wiper 70 can include a metal layer surrounded by rubber. However, appropriate care must be taken during design of this particular wiper such that the metal content of the wiper will never contact the interior wall 56, even after anticipated wear of the relatively soft wiper material. Metal-on-metal contact within the impeller housing can be detrimental to performance of the snow thrower 20.

[0053] In one example, the lengths of the mounting slots 94, 98 and the mounting length 114 and the lengths of the wiper portion 86 can be designed, calculated, and manufactured such that the wiper 70 does not reach the limit of its radially outward potential movement prior to the anticipated life cycle of the snow thrower 20, even when considering normal wear effects on the wiper 70. In another example, the wipers 70 can be replaced by new wipers 70 in the event that so much

material has worn away from the wiper 70 that contact is no longer maintained with the interior wall 56. In yet another example, the relatively soft material used for the wiper 70 may enable an operator to cut away a part of the wiper portion 86, enabling the wiper 70 to move farther outward radially to maintain contact with the interior wall 56. Other examples of wipers may include removable sections of the wiper portion 86, enabling the same effect of cutting away a portion of the wiper 70.

[0054] In one example, the impeller blade 66 can be substantially flat and straight, extending from the hub 64 along a radius of the impeller 54. In another example, as shown in FIGS. 4-8, the impeller blade 66 includes a first blade portion 116 and a second blade portion 118. The first blade portion 116 and the second blade portion 118 can be positioned such that the second blade portion 118 of the impeller blade 66 extends at a non-zero angle from the first blade portion 116 of the impeller blade 66. In other words, the first blade portion 116 and the second blade portion 118 form an angle that is not 0° or 180° . In yet another example, the impeller blade 66 can be formed in a curvilinear fashion rather than the segmented linear portions previously described. The curvilinear construction can be constructed such that the second blade portion 118 is simply a curved part of the impeller blade 66 that is closer to the outer circumference 60.

[0055] In some examples, as shown in FIGS. 4-7, the second blade portion 118 of the impeller blade 66 is positioned at an angle from the first blade portion 116 such that the second blade portion 118 extends toward a direction of rotation (as represented by arrow 80) of the impeller 54. This position may also be described as positioning the second blade portion 118 to be "swept toward" the direction of rotation 80 of the impeller 54. In this position, an edge 120 of the second blade portion 118 passes by a stationary point on the interior wall 56 prior to any other segment of the second blade portion 118 during rotation of the impeller 54. At times, it can be advantageous to orient the second blade portion 118 toward the direction of rotation 80, as the velocity of the collected snow, ice, water, etc. thrown by the impeller 54 can exceed the tip speed velocity of the impeller 54. This can lead to greater throw distances of snow, ice, water, etc. when compared to the throw distances developed by impellers having impeller blades that are not swept toward the direction of rotation of the impeller 54.

[0056] This increase in velocity is depicted in FIG. 4. A radius 124 of the impeller 54 is shown, and the magnitude of the angular velocity of a snow or ice

particle leaving the impeller blade 66 is represented by the length of the vector 126 which is equal to the tip velocity of the impeller blade 66. However, the swept forward orientation of the second blade portion 118 imparts another vector component to the particle velocity as represented by the length of the vector 128. The sum of the velocity vectors 126, 128 is represented by the vector 130 having a magnitude larger than the tip velocity of the impeller blade 66.

[0057] In other examples, as the one shown in FIG. 8, the second blade portion 118 of the impeller blade 66 is positioned at an angle from the first blade portion 116 such that the second blade portion 118 extends away from the direction of rotation 80 of the impeller 54. This position may also be described as orienting the second blade portion 118 to be “swept away” from the direction of rotation 80 of the impeller 54. At times, it can be advantageous to position the second blade portion 118 away from the direction of rotation 80, as this can increase the efficiency of the impeller.

[0058] In another example, each blade 46 includes a tip 50 that extends from the end of the blade 46 in a curved manner. The tips 50 are curved in the direction of rotation of the impeller 54. The curved tips 50 assist in maintaining contact between the snow and the blades 46 as the impeller 54 rotates, thereby preventing the snow from sliding past the ends of the blades 46 to the gap between the blades 46 and the impeller housing 34 before the snow is thrown into and from the chute 26. Preventing the snow from sliding past the end of the blades 46 results in less re-circulation of the snow within the impeller housing 34, thereby making the snow thrower 20 more efficient in expelling the snow. Whereas the augers 46 are configured to push snow axially along the axis of rotation of the auger 46, the impeller 54 is configured to drive or throw snow in a radial direction away from the axis of rotation of the impeller 54. The impeller 54 and the auger 46 immediately adjacent thereto are oriented and timed such that they rotate at the same angular velocity, wherein as the snow slides from the end of the flight 36 of the auger 46 toward the impeller 54, the impeller 54 is positioned such that the snow enters the gap between adjacent blades 46 of the impeller 54 so that re-circulation of the snow is reduced.

[0059] Turning to FIGS. 12 and 13, another embodiment of the impeller assembly 24 is shown. As shown in FIG. 12, the impeller 54 can include four (4) impeller blades 66. In one example, the back plate 68 can include a number of lobes

134 commensurate with the number of impeller blades 66. In other examples, the back plate 68 can be circular as shown in several of the previous figures. Similarly, as shown in FIG. 13, the impeller 54 can include three (3) impeller blades 66 and lobes 134. In some example snow throwers 20, the choice of the number of impeller blades 66 used on the impeller 54 can be determined using an anticipated flow rate of snow entering the impeller housing 34 (best seen in FIG. 2). For example, a greater number of impeller blades 66 can be more efficient when the snow thrower 20 is used for greater flow rates of snow entering the impeller housing 34.

[0060] Turning to FIG. 14, the impeller blade 66 can include at least one tab 136 that can be used to mount the impeller blade 66 to the back plate 68 through slots 138 (best seen in FIG. 12). In one example, the back plate 68 can include a number of slots and/or slot patterns that can accommodate various styles of impeller blades 66. Any suitable attachment method can be used to attach the impeller blades 66 to the back plate 68. Additionally, the impeller blade 66 can define a plurality of mounting slots 84. In one example, the mounting slots 84 are vertically oriented with two smaller mounting slots 140 located relatively close to the hub 64, and one larger mounting slot 144 located closer to the outer circumference of the impeller 54.

[0061] Turning to FIG. 15, a wiper 138 can be configured to interact with the impeller blade 66 of the embodiment shown in FIGS. 12 and 13. A first end portion 146 of the wiper 138 passes through one of the smaller mounting slots 140 and then through another smaller mounting slot 140 such that the wiper 138 is “woven” through the smaller mounting slots 140 and mounts the wiper 138 to the impeller 54. The first end portion 146 can include a shoulder 150 which can limit the length of the wiper 138 that can be woven into the impeller blade 66. The wiper 138 can be pulled tight by the operator pulling on the first end portion 146 in the direction of arrow 147 as shown in FIGS. 12 and 13. This woven feature can act as both a locking feature for the wiper 138 and a feature to prevent the first end portion 146 from slapping the impeller blade 66 during operation. Additionally, the wiper 138 is configured to be mounted to the impeller blade 66 without the need for tools, similar to the operation shown in FIG. 10.

[0062] Returning to FIG. 12, a second end portion 148 of the wiper 138 which is closer to the outer circumference 60 is configured to pass through the larger mounting slot 144. Similar to the first end portion 146, the second end portion 148 can include a shoulder 154 that contacts a portion of the impeller blade 66 at each end

of the larger mounting slot 144. This interaction provides a physical interference that prevents the wiper 138 from moving through the larger mounting slot 144 toward the outer circumference 60 beyond a desired distance. In some examples, there can be a benefit to limiting the distance that the wiper 138 extends beyond the outer circumference 60 of the impeller 54. For example, the wiper 138 can be used to limit the distance between the impeller blade 66 and the interior wall 56, but not touch the interior wall 56. In this way, the wiper 138 will likely not contact the outlet aperture 38 (also known as a blower cup in some instances) which can create an undesirable loud noise caused by the slapping of the wiper 138 as it contacts the outlet aperture 38 on each rotation.

[0063] It is to be noted that the impeller assemblies shown in FIGS. 12 and 13 include the wiper 138 mounted on the trailing side 106 of the impeller blade 66. This mounting location can provide the benefit of a relatively smooth surface for snow, ice, water, etc. to flow along the surface of the impeller blade 66 as it undergoes centrifugal force, propelling it outward along the face of the impeller blade 66. This is true for all of the embodiments in this disclosure that include the wiper mounted on the trailing side 106 of the impeller blade 66.

[0064] The description now turns to a method of improving an efficiency of a snow thrower impeller. The method includes the step of providing a multiple-stage snow thrower including the impeller assembly. The impeller assembly includes the impeller housing that defines the interior wall. The impeller assembly also includes the impeller located within the impeller housing. The impeller includes a central axis of rotation and an outer circumference while defining a mounting slot.

[0065] The impeller includes a hub located about the central axis of rotation and the impeller blade connected to the hub. The impeller blade extends from the hub toward the outer circumference. The impeller assembly also includes the wiper mounted adjacent the impeller blade. The wiper includes the wiper portion that enables insertion of the wiper portion into the mounting slot without the use of fasteners or tools. The wiper contacts the interior wall of the impeller assembly during rotational operation of the impeller in order to limit the gap between the impeller blade and the interior wall. The method also includes the step of inserting the wiper into the mounting slot by hand and without the use of tools. The method still further includes the step of operating the impeller by providing a rotational force

to the impeller, and the wiper maintains contact with the interior wall during impeller rotation.

[0066] While this disclosure has been written in conjunction with the specific embodiments described above, it is evident that many alternatives, combinations, modifications and variations are apparent to those skilled in the art. Accordingly, the described embodiments of this disclosure, as set forth above are intended to be illustrative only, and not in a limiting sense. Various changes can be made without departing from the spirit and scope of this disclosure. Combinations of the above embodiments and other embodiments will be apparent to those of skill in the art upon studying the above description and are intended to be embraced therein. Therefore, the scope of the present disclosure is defined by the appended claims, and all devices, processes, and methods that come within the meaning of the claims, either literally or by equivalence, are intended to be embraced therein. Furthermore, to the extent that the term “includes” is used in either the detailed description or the claims, such term is intended to be inclusive in a manner similar to the term “comprising” as “comprising” is interpreted when employed as a transitional word in a claim.

[0067] What is claimed is:

CLAIMS

1. An impeller assembly (24), said impeller assembly characterized by:
an impeller (54) located within an associated impeller housing (34), the associated impeller housing defines an interior wall (56), said impeller includes a central axis of rotation (58) and an outer circumference (60), said impeller defines a mounting slot (84), said impeller comprising:
a hub (64) located about said central axis of rotation;
an impeller blade (66) connected to said hub, wherein said impeller blade extends from said hub toward said outer circumference; and
a wiper (70) mounted adjacent said impeller blade, said wiper comprising a wiper portion (86) that slides into said mounting slot to mount said wiper to said impeller;
wherein said wiper contacts said interior wall of the associated impeller housing during rotational operation of said impeller in order to limit a gap (74) between said impeller blade and said interior wall.
2. The impeller assembly (24) according to claim 1, further characterized in that said wiper (70) is configured to be mounted without the use of fasteners or tools.
3. The impeller assembly (24) according to claims 1-2, further characterized in that said wiper (70) comprises a flexible, resilient material that can be deformed from an original shape upon application of pressure from an operator's hand and return to the original shape upon removal of the application of pressure from the operator's hand to fit into said mounting slot (84).
4. The impeller assembly (24) of claims 1-3, further characterized in that construction of said impeller and (54) said wiper (70) enable said wiper to move in a generally radial direction away from said hub (64) in order to maintain contact with said interior wall (56).
5. The impeller assembly (24) of claims 1-4, further characterized in that said wiper portion (86) is oriented radially and said mounting slot (84) is oriented radially.

6. The impeller assembly (24) of claims 1-4, further characterized in that said wiper portion (86) is oriented axially, and said mounting slot (108) is oriented axially.
7. The impeller assembly (24) of claims 1-6, further characterized in that said impeller assembly comprises a plurality of retainer plates (104) on a trailing side (106) of said impeller blade (66), wherein said retainer plates define said mounting slots (108).
8. The impeller assembly (24) of claim 7, further characterized in that said wiper portion (86) includes a first wiper length (110) and one of said retainer plates (104) is mounted a distance of a mounting length (94, 98) from the other of said retainer plates, wherein said mounting length is greater than said first wiper length thereby enabling said wiper (70) to move in a generally radial direction (112) away from said hub (64) in order to maintain contact with said interior wall (56).
9. The impeller assembly (24) of claims 1-8, further characterized in that said impeller assembly comprises a back plate (68), wherein said hub (64) is attached to said back plate located about said central axis of rotation (58).
10. The impeller assembly (24) of claim 9, further characterized in that said impeller blade (66) extends from an interior location of said back plate (68) toward said outer circumference, said impeller blade is connected to said hub (64) through said back plate.
11. The impeller assembly (24) according to claims 9-10, further characterized in that said impeller assembly comprises an upper blade extension (76) attached to said impeller blade (66), wherein said upper blade extension defines an upper mounting slot (88) on a leading face side (90) of said impeller blade.
12. The impeller assembly (24) according to claim 11, further characterized in that said wiper portion (86) includes a first wiper length (110) and said upper mounting slot (88) includes an upper mounting slot length (94) and wherein said upper mounting slot length is greater than said first wiper length, thereby enabling said wiper (70) to move in a generally radial direction (112) from said hub (64) in order to maintain contact with said interior wall (56).

13. The impeller assembly (24) according to claim 12, further characterized in that said back plate (68) defines a lower mounting slot (96) generally opposing said upper mounting slot (88) defined by said upper blade extension (76).

14. The impeller assembly (24) according to claim 13, further characterized in that said lower mounting slot (96) includes a lower mounting slot length (98) and wherein said lower mounting slot length is greater than said first wiper length (110), thereby enabling said wiper (70) to move in a generally radial direction (112) from said hub in order to maintain contact with said interior wall (56).

15. The impeller assembly (24) according to claims 1-14, further characterized in that said impeller assembly comprises a plurality of mounting slots (140), wherein an end portion (146) of said wiper (138) passes through one of said mounting slots and then passes through another of said mounting slots to mount said wiper to said impeller (54).

16. An impeller assembly (24), said impeller assembly characterized by:
an impeller (54) located within an associated impeller housing (34), the associated impeller housing comprises an interior wall (56), said impeller includes a central axis of rotation (58) and an outer circumference (60), said impeller comprising:

a hub (64) located about said central axis of rotation; and
an impeller blade (66) connected to said hub, said impeller blade comprising a first blade portion (116) and a second blade portion (118), wherein said impeller blade extends from said hub toward said outer circumference, wherein said second blade portion of said impeller blade extends at a non-zero angle from said first blade portion of said impeller blade.

17. The impeller assembly (24) of claim 16, further characterized in that said second blade portion (118) of said impeller blade (66) extends toward a direction of rotation (80) of said impeller (54).

18. The impeller assembly (24) of claim 16, further characterized in that said second blade portion (118) of said impeller blade (66) extends away from a direction of rotation (80) of said impeller (54).

19. A method of improving an efficiency of a snow thrower impeller (54) characterized by:

providing a multiple-stage snow thrower (20) comprising an impeller assembly (24), said impeller assembly comprising:

an impeller housing (34), said impeller housing defines an interior wall (56);
an impeller (54) located within said impeller housing, said impeller including a central axis of rotation (58) and an outer circumference (60), said impeller defines a mounting slot (84), said impeller comprising:

a hub (64) located about said central axis of rotation;

an impeller blade (66) connected to said hub, wherein said impeller blade extends from said hub toward said outer circumference; and

a wiper (70) mounted adjacent said impeller blade, said wiper comprising a wiper portion (86);

wherein said wiper is mounted without the use of fasteners or tools;

wherein said wiper contacts said interior wall of said impeller assembly during rotational operation of said impeller in order to limit a gap between said impeller blade and said interior wall;

inserting said wiper into said mounting slot by hand and without the use of tools;

operating said impeller by providing a rotational force to said impeller, wherein said wiper maintains contact with said interior wall during impeller rotation.

20. The method of claim 19, further characterized in that construction of said impeller (54) and said wiper (70) enable said wiper to move in a generally radial direction (112) away from said hub (64) in order to maintain contact with said interior wall (56).

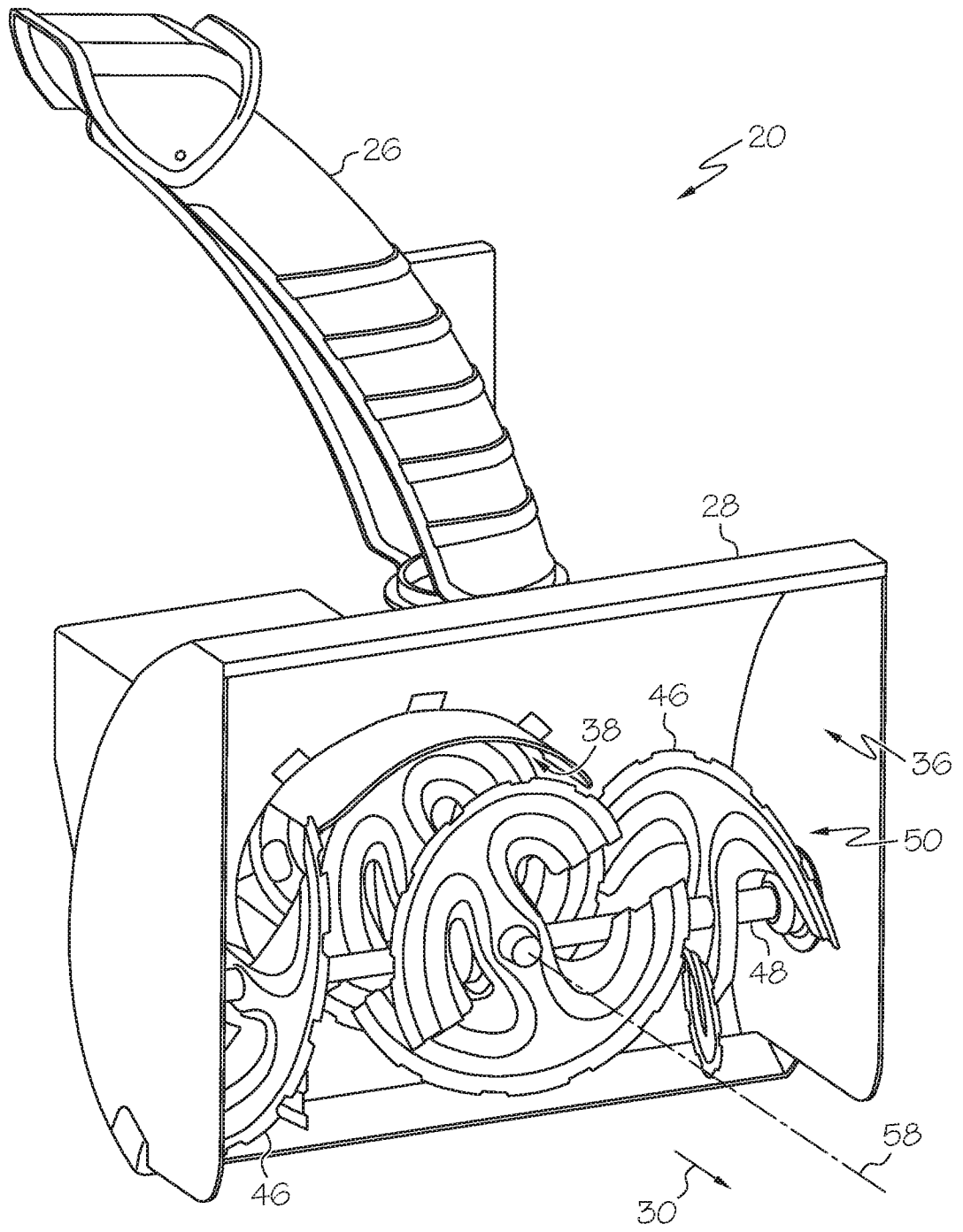
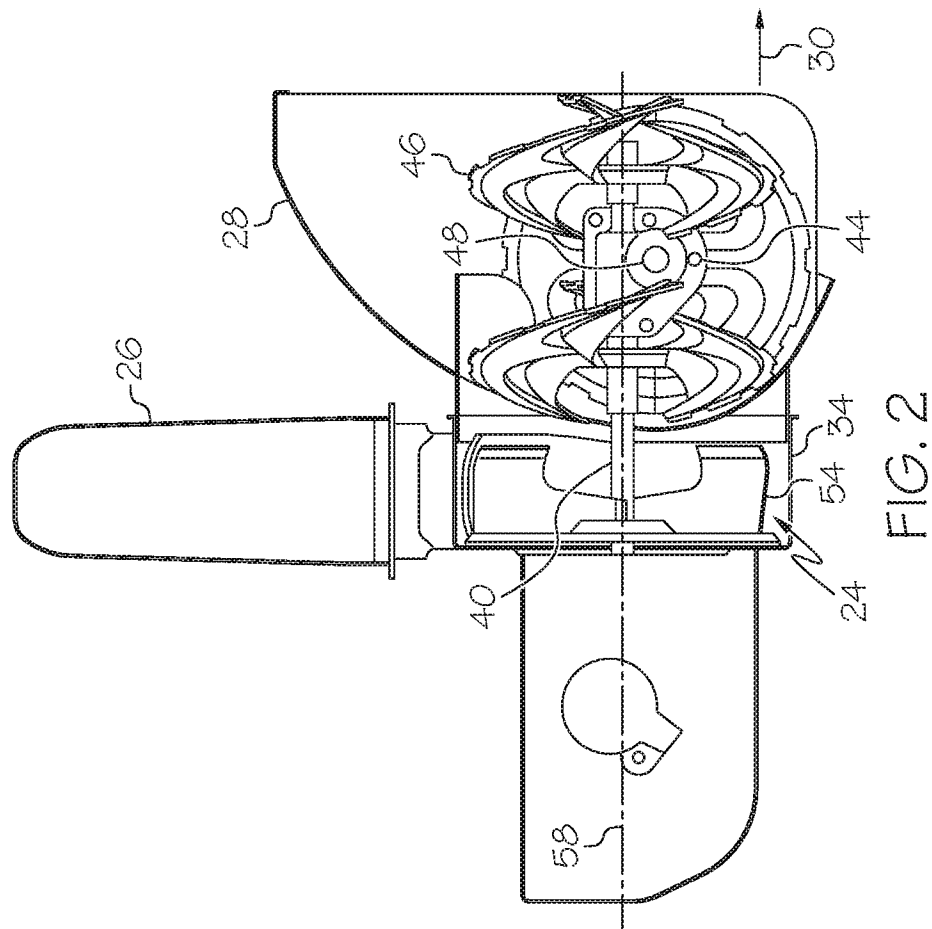
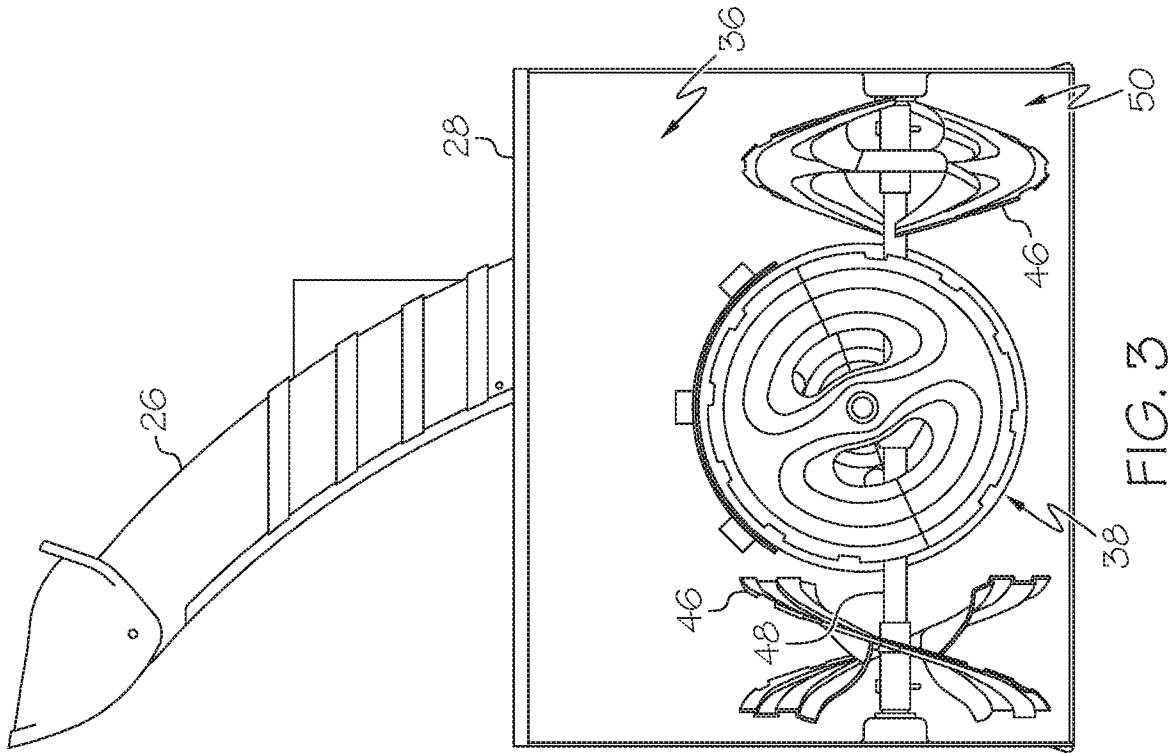

FIG. 1

2 / 11



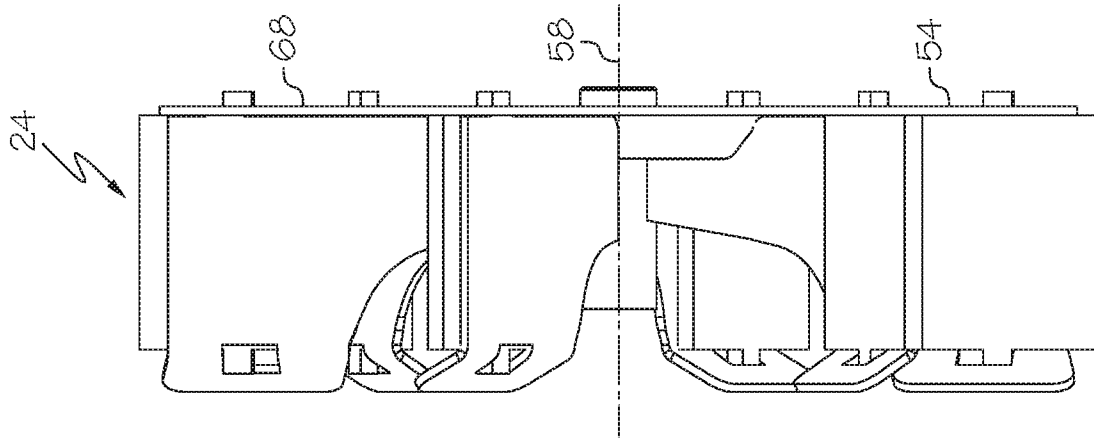

FIG. 5

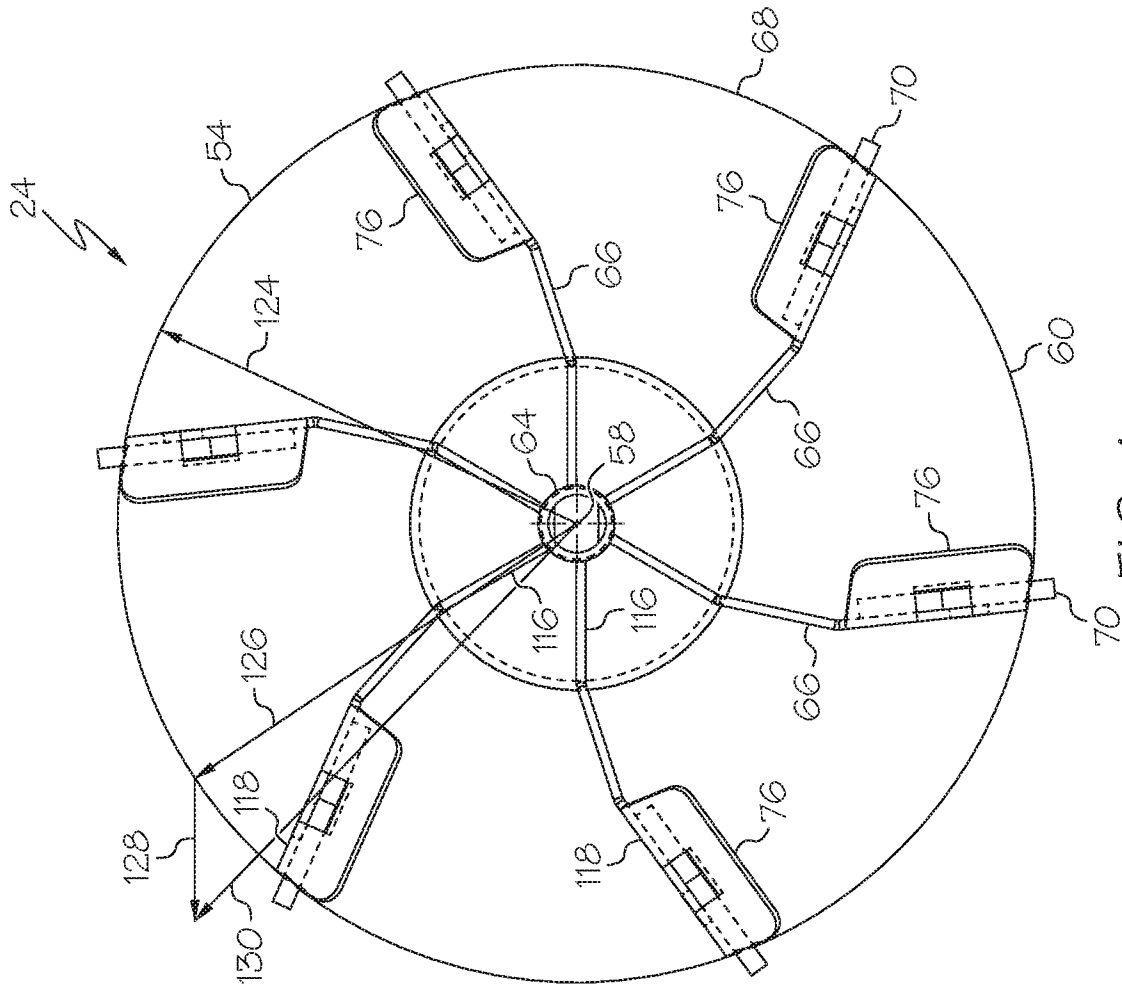

FIG. 4

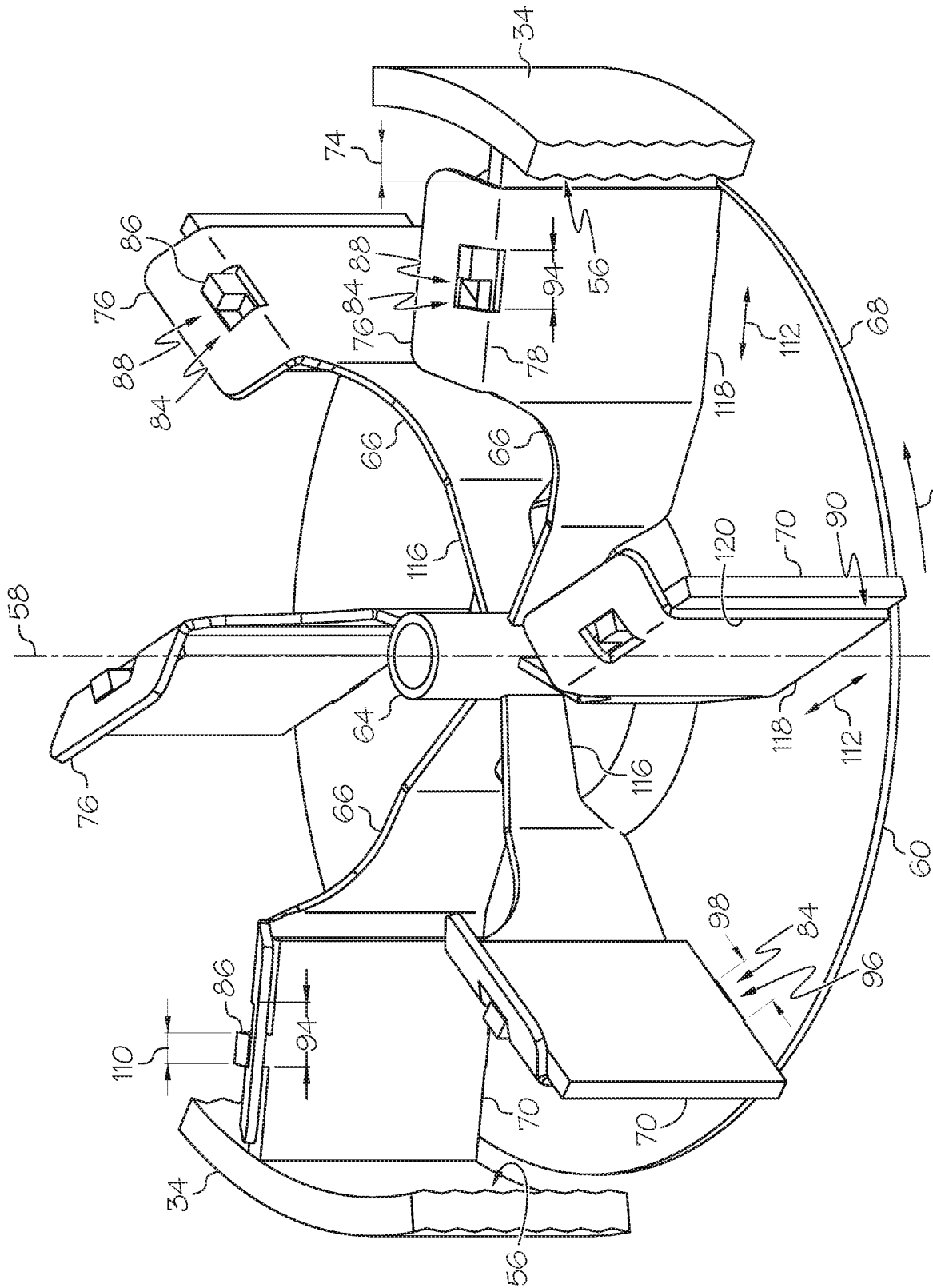

FIG. 6

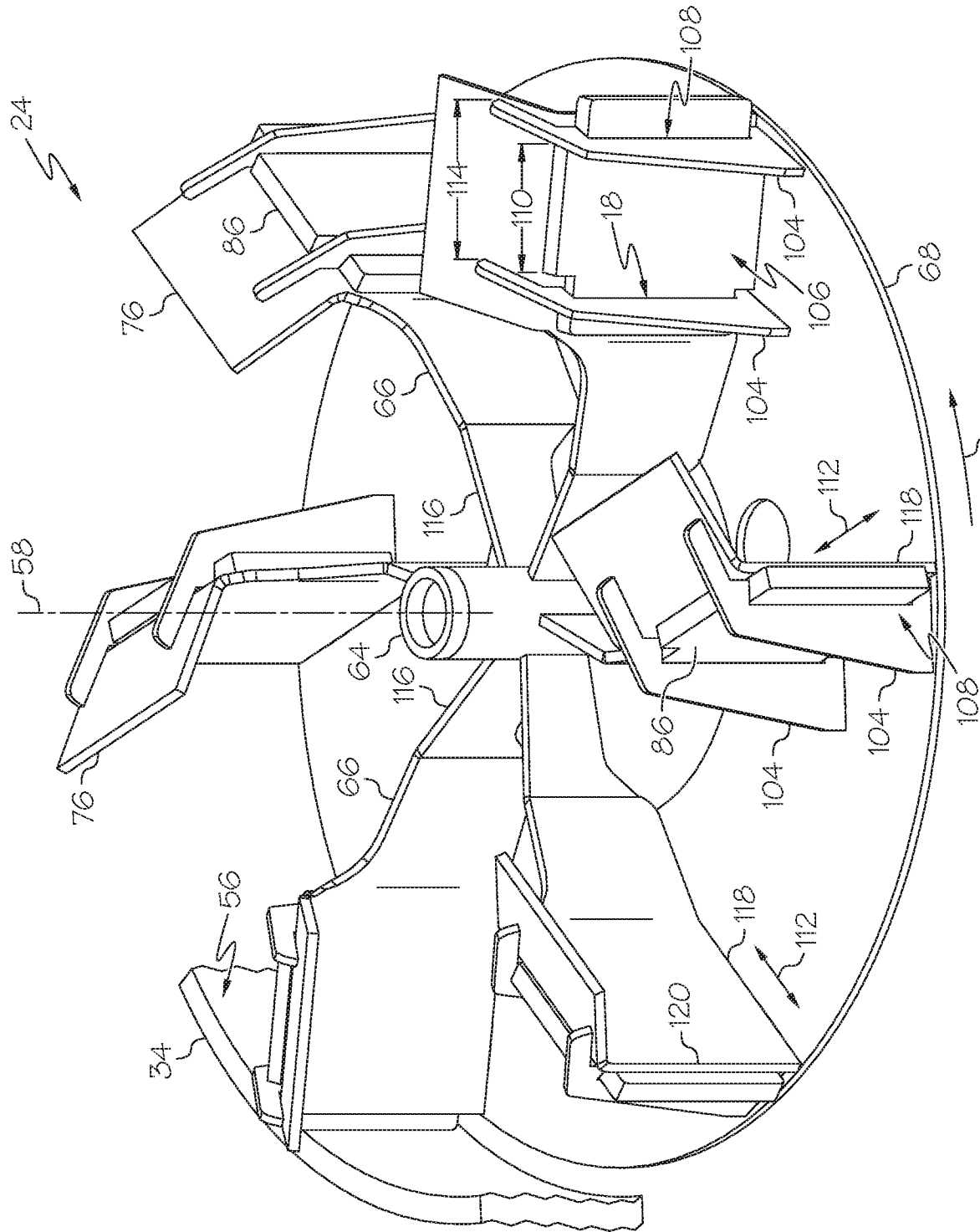

FIG. 7

7 / 11

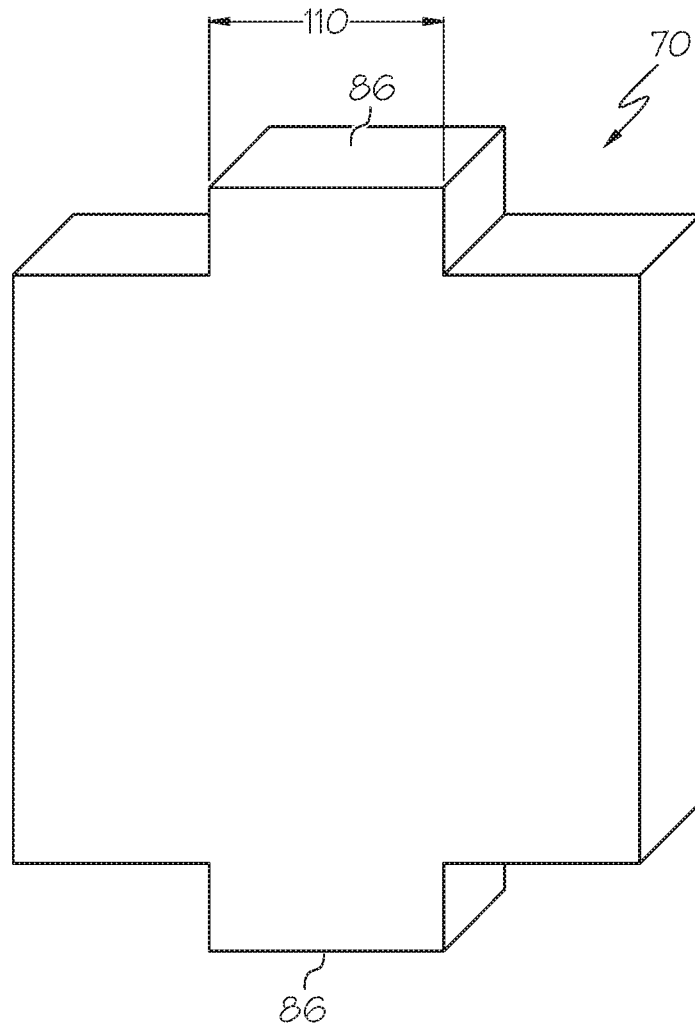

FIG. 9

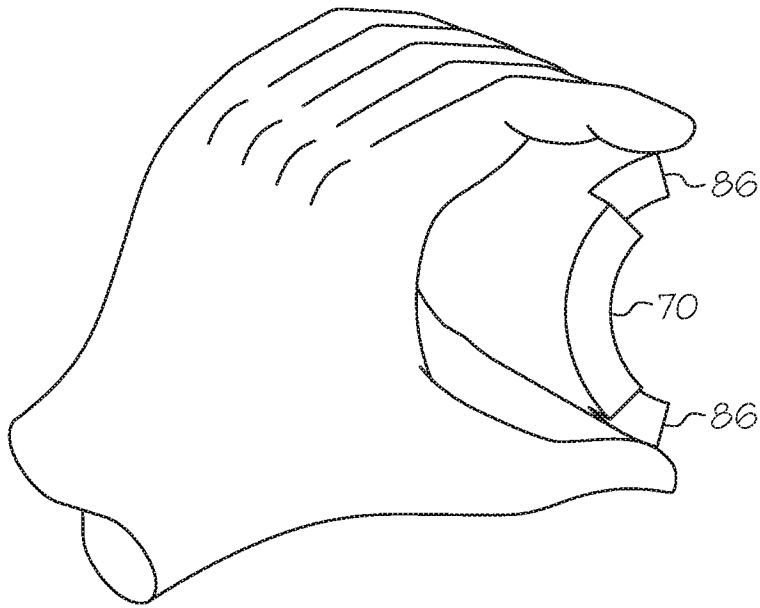

FIG. 10

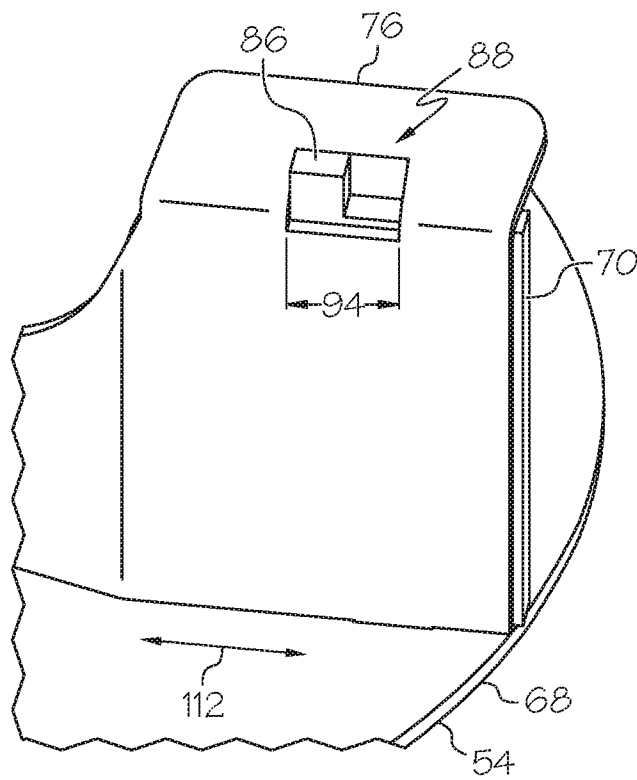

FIG. 11

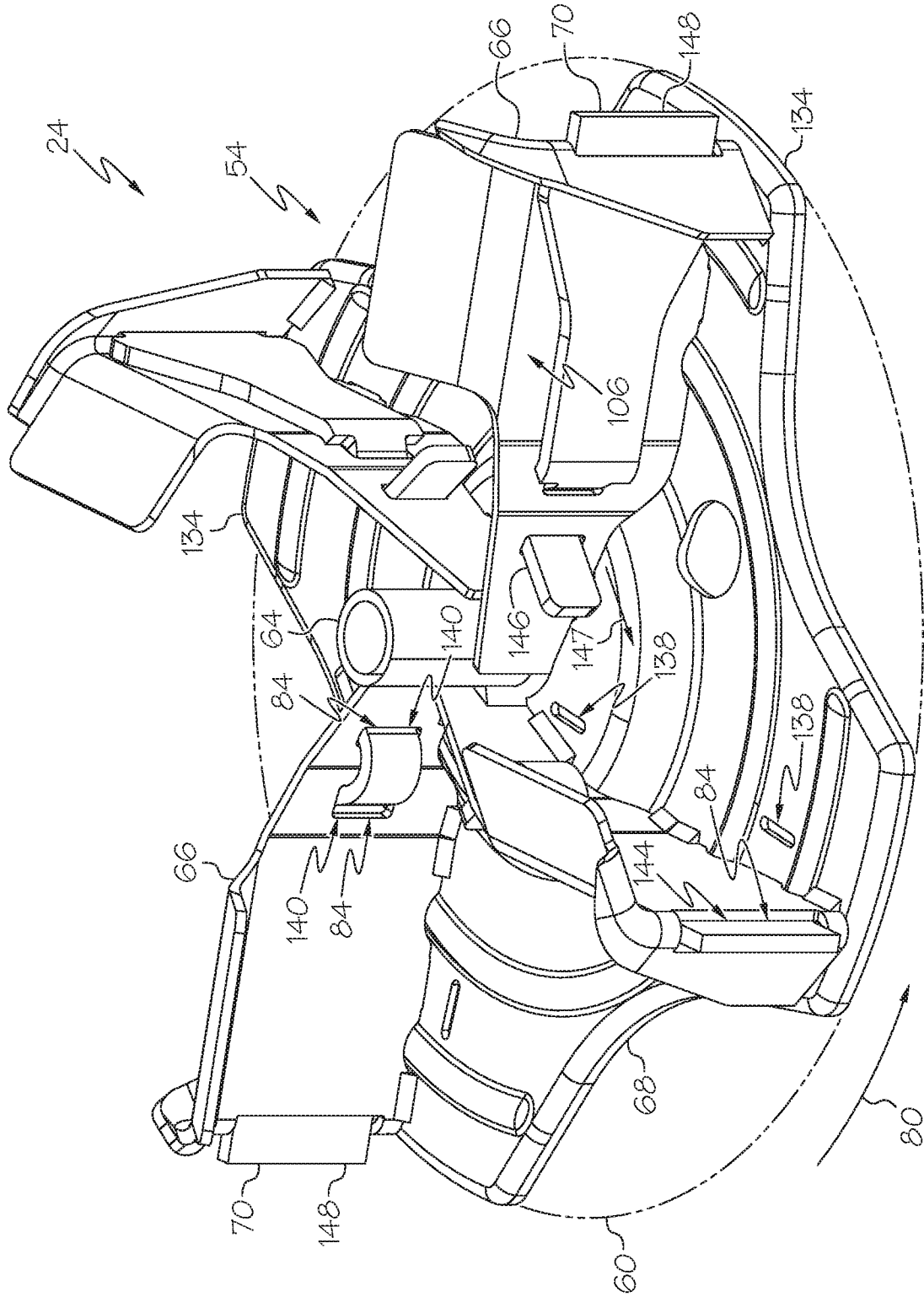

FIG. 12

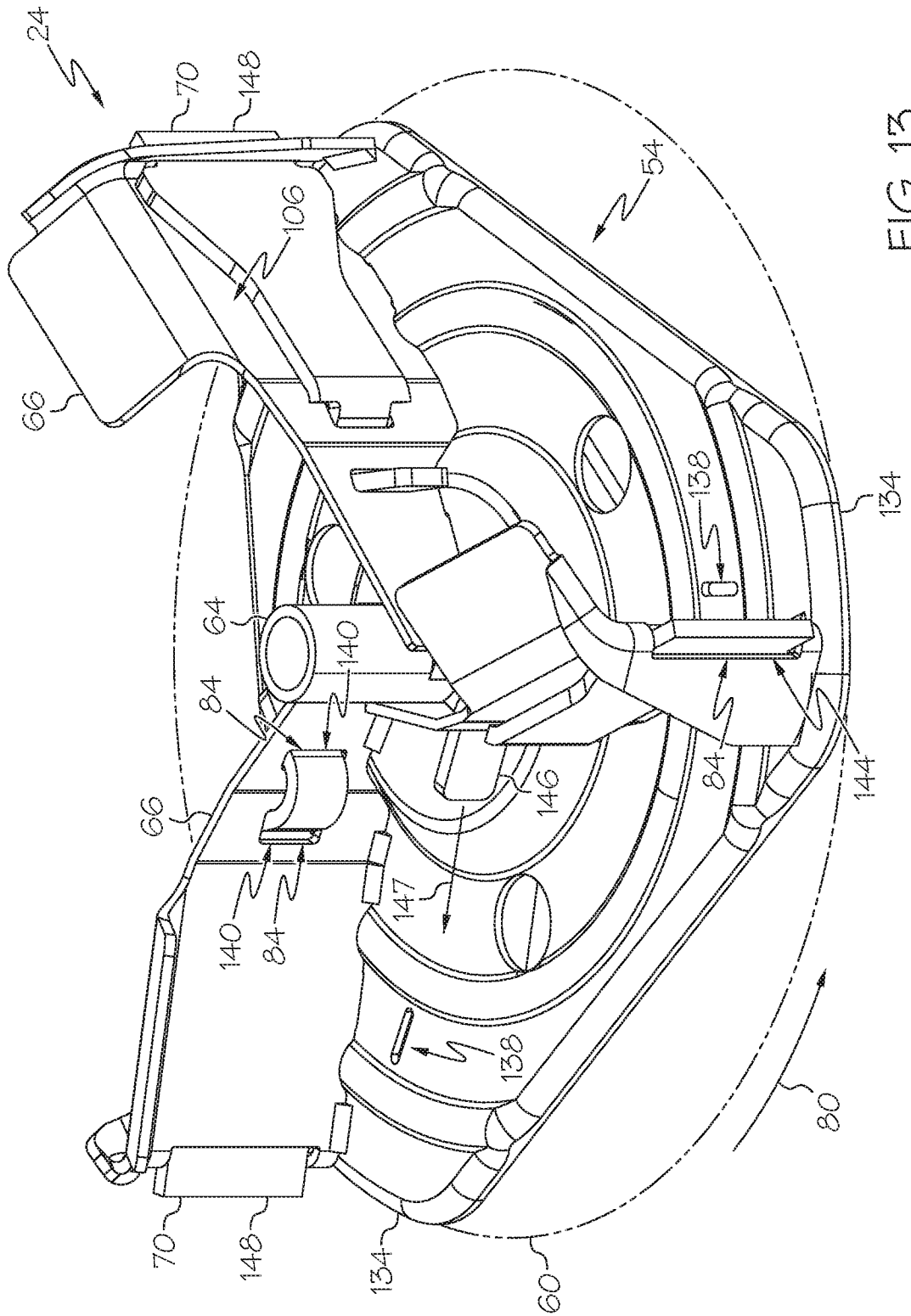
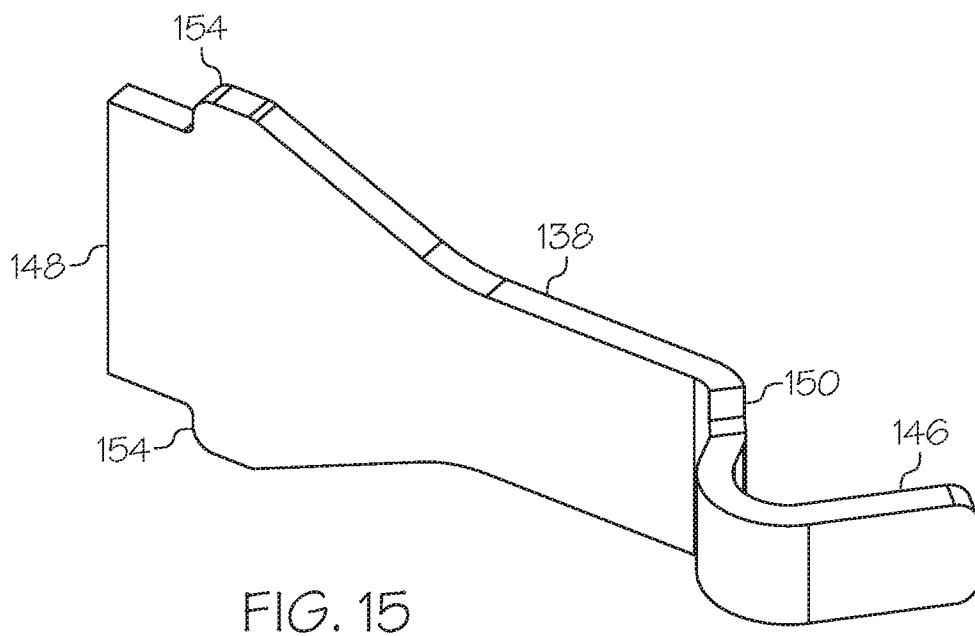
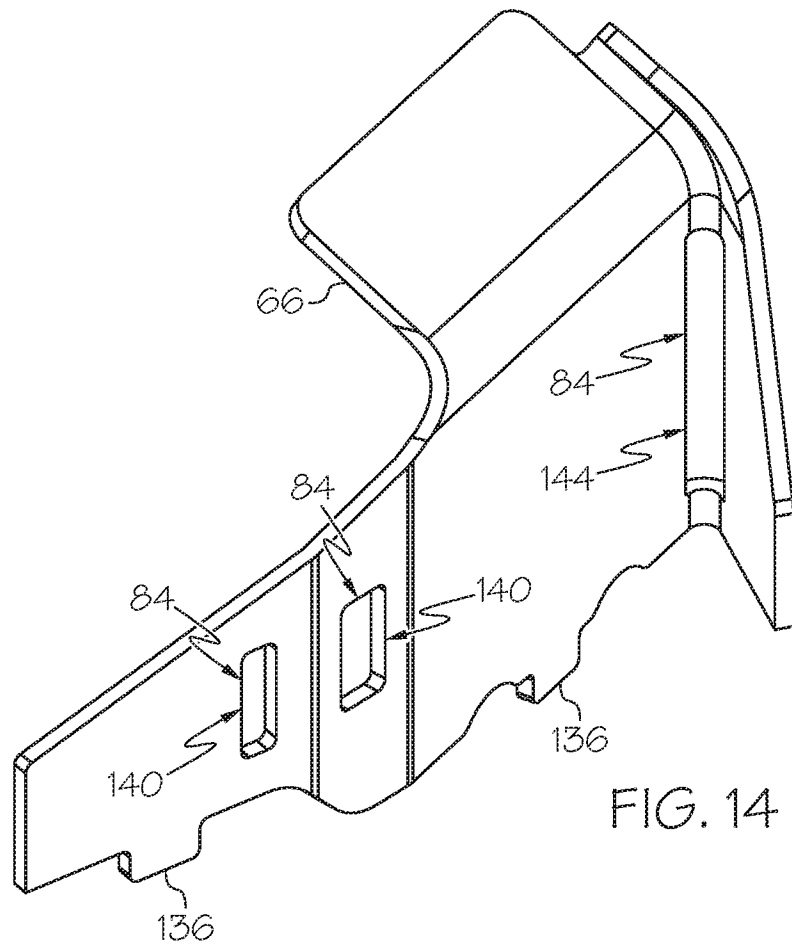

FIG. 13



INTERNATIONAL SEARCH REPORT

International application No PCT/US2016/015111

A. CLASSIFICATION OF SUBJECT MATTER
 INV. E01H5/04
 ADD.
 According to International Patent Classification (IPC) or to both national classification and IPC

B. FIELDS SEARCHED
 Minimum documentation searched (classification system followed by classification symbols)
 E01H F04D

Documentation searched other than minimum documentation to the extent that such documents are included in the fields searched

Electronic data base consulted during the international search (name of data base and, where practicable, search terms used)
 EPO-Internal

C. DOCUMENTS CONSIDERED TO BE RELEVANT

Category*	Citation of document, with indication, where appropriate, of the relevant passages	Relevant to claim No.
X A	US 3 151 784 A (TAILOR JOHN P) 6 October 1964 (1964-10-06) figure 3 -----	1-6,15, 19,20 8
X A	US 4 155 486 A (BROWN WINFRED E [US]) 22 May 1979 (1979-05-22) figure 2 -----	1-7,19, 20 8
A	WO 2010/095233 A1 (YAMAHA MOTOR POWER PRODUCTS KA [JP]; KANAZAWA ATSUSHI [JP]) 26 August 2010 (2010-08-26) abstract; figure 3 -----	1,19

Further documents are listed in the continuation of Box C. See patent family annex.

* Special categories of cited documents :

"A" document defining the general state of the art which is not considered to be of particular relevance	"T" later document published after the international filing date or priority date and not in conflict with the application but cited to understand the principle or theory underlying the invention
"E" earlier application or patent but published on or after the international filing date	"X" document of particular relevance; the claimed invention cannot be considered novel or cannot be considered to involve an inventive step when the document is taken alone
"L" document which may throw doubts on priority claim(s) or which is cited to establish the publication date of another citation or other special reason (as specified)	"Y" document of particular relevance; the claimed invention cannot be considered to involve an inventive step when the document is combined with one or more other such documents, such combination being obvious to a person skilled in the art
"O" document referring to an oral disclosure, use, exhibition or other means	"&" document member of the same patent family
"P" document published prior to the international filing date but later than the priority date claimed	

Date of the actual completion of the international search 21 March 2016	Date of mailing of the international search report 20/06/2016
--	--

Name and mailing address of the ISA/ European Patent Office, P.B. 5818 Patentlaan 2 NL - 2280 HV Rijswijk Tel. (+31-70) 340-2040, Fax: (+31-70) 340-3016	Authorized officer Saretta, Guido
--	--

INTERNATIONAL SEARCH REPORT

International application No.
PCT/US2016/015111

Box No. II Observations where certain claims were found unsearchable (Continuation of item 2 of first sheet)

This international search report has not been established in respect of certain claims under Article 17(2)(a) for the following reasons:

1. Claims Nos.:
because they relate to subject matter not required to be searched by this Authority, namely:

2. Claims Nos.:
because they relate to parts of the international application that do not comply with the prescribed requirements to such an extent that no meaningful international search can be carried out, specifically:

3. Claims Nos.:
because they are dependent claims and are not drafted in accordance with the second and third sentences of Rule 6.4(a).

Box No. III Observations where unity of invention is lacking (Continuation of item 3 of first sheet)

This International Searching Authority found multiple inventions in this international application, as follows:

see additional sheet

1. As all required additional search fees were timely paid by the applicant, this international search report covers all searchable claims.

2. As all searchable claims could be searched without effort justifying an additional fees, this Authority did not invite payment of additional fees.

3. As only some of the required additional search fees were timely paid by the applicant, this international search report covers only those claims for which fees were paid, specifically claims Nos.:

4. No required additional search fees were timely paid by the applicant. Consequently, this international search report is restricted to the invention first mentioned in the claims; it is covered by claims Nos.:

see additional sheet(s)

Remark on Protest

- The additional search fees were accompanied by the applicant's protest and, where applicable, the payment of a protest fee.
- The additional search fees were accompanied by the applicant's protest but the applicable protest fee was not paid within the time limit specified in the invitation.
- No protest accompanied the payment of additional search fees.

FURTHER INFORMATION CONTINUED FROM PCT/ISA/ 210

This International Searching Authority found multiple (groups of) inventions in this international application, as follows:

1. claims: 1-15, 19, 20

Assembly comprising a housing and an impeller, with a hub, a blade and a wiper, wherein the wiper contacts an interior wall of the housing during rotational operation of the impeller.

2. claims: 16-18

Assembly comprising a housing and an impeller, with a hub and a blade, the blade comprising a first portion extending from the hub and a second portion extending at a non-zero angle from the first portion.

INTERNATIONAL SEARCH REPORT

Information on patent family members

International application No

PCT/US2016/015111

Patent document cited in search report		Publication date	Patent family member(s)	Publication date
US 3151784	A	06-10-1964	NONE	

US 4155486	A	22-05-1979	NONE	

WO 2010095233	A1	26-08-2010	NONE	
