

REPUBLIC OF SOUTH AFRICA
PATENTS ACT, 1978

PUBLICATION PARTICULARS AND ABSTRACT

(Section 32(3)(a) - Regulations 22(i)(g) and 31)

OFFICIAL APPLICATION NO.			LODGING DATE		ACCEPTANCE DATE	
21	01	2002/0336	23	15 January 2002	43	24-7-2002

INTERNATIONAL CLASSIFICATION		NOT FOR PUBLICATION	
51	A61B	CLASSIFIED BY :	

FULL NAME(S) OF APPLICANT(S)

71	SYNTHESE AG CHUR
----	------------------

FULL NAME(S) OF INVENTOR(S)

72	FREI, Reto; HEHLI, Markus; DUDA, Georg
----	--

EARLIEST PRIORITY CLAIMED	COUNTRY	NUMBER	DATE
NOTE : The country must be indicated by its International Abbreviation - see Schedule 4 of the Regulations.	33 DE	31 299 13 994.8	32 11 August 1999

TITLE OF INVENTION

54	SURGICAL GUIDE BODY
----	---------------------

57	ABSTRACT (NOT MORE THAN 150 WORDS)	NUMBER OF PAGES	37
----	------------------------------------	-----------------	----

FOR ABSTRACT SEE THE NEXT SHEET



WO 01/12081 A1

(54) Title: SURGICAL GUIDE BODY

(54) Bezeichnung: CHIRURGISCHER FÜHRUNGSKÖRPER

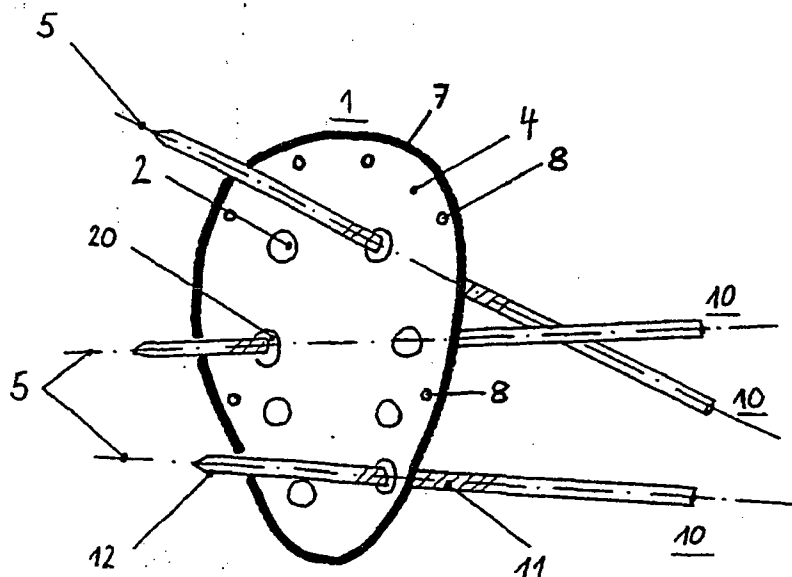

(57) Abstract: The invention relates to a surgical guide body (1) which is designed to receive longitudinal fixation elements (10) such as wires, nails, pegs or screws which are to be fixed to the bones. The inventive guide body comprises an upper side (3), a lower side (4) and at least three openings (2) connecting the upper side (3) to the lower side (4) of said guiding body. The centre point of said openings is not located on a straight line. The central axes (5) of at least two of the openings are skewed in relation to each other. The guide body (1) enables the fixation elements (10) to be inserted at various intersecting angles. The guide body (1) primarily prevents movement both towards the proximal and distal parts of the fixation elements (10) which extend within the spongiosa or intramedullar region.

[Fortsetzung auf der nächsten Seite]

1760/PCT

7.3.2000

English translation of the International Patent Application
5 No. PCT/CH00/00129 "Surgical guide body" in the name of
Synthes AG Chur

Surgical guide body

10 The invention relates to a guide body designed to receive
longitudinal fixation elements as claimed in the
precharacterising part of claim 1 and to fixation devices
including such a guide body as claimed in the
precharacterising parts of claims 15 and 24.

15

The guide body may have the function of an internal fixator
for osteosynthesis and may be used in the proximal part of
the humerus or in other regions of long bones situated
close to a joint.

20

A fan-like, corrugated guiding device designed to guide
Kirschner wires is known from US 5,476,467 BENOIST. This
arrangement suffers from the disadvantages that the
fixation elements (Kirschner wires) can only be passed
25 through the guide parallel to each other. In addition,
there is no possibility of using sutures to attach the
pieces or parts of fractured bone which cannot be reached
by Kirschner wires. Due to its corrugated structure, the
guiding device does not rest directly on the bone, which
30 superfluously makes it necessary to use wires of greater
length.

The invention is intended to provide a remedy for this. It is accordingly an object of the invention to create a guide body designed to receive longitudinal fixation elements to be anchored within the bone which makes it possible to insert fixation elements at various intersecting angles. The guide body primarily prevents the wires extending into the intramedullary region or the spongiosa from getting displaced either in the proximal or in the distal direction.

10

According to the invention, this object is achieved by means of a guide body which shows the features of claim 1 and of two fixation devices which show the features of claims 15 and 24.

15

The advantage achieved by the invention is that a minimally invasive surgical technique may be used and that the implant material to be inserted is reduced to a minimum. Due to the possibility of arranging the fixation elements in three dimensions, the guide body according to the invention is particularly suitable for osteosynthesis in cases of osteoporotic bone or bone struck by a disease. The stability of the osteosynthesis device is primarily achieved by the pegs or wires and their crosswise positioning within the bone. Due to the direct contact of the guide body with the bone, the parts of the wires to be inserted which are not in contact with the bone are reduced to a minimum. This makes it possible for the patient to put weight on the fracture site earlier, to use the injured limbs earlier and, ideally, to benefit from an accelerated healing process.

20
25
30

According to a preferred improvement of the invention, one of the openings of the guide body is provided with an internal screw thread so that fixation elements having an external screw thread may also be inserted.

5

The openings of the guide body suitably have a diameter of between 2 and 6 mm.

According to a preferred improvement of the invention, the
10 guide body is provided with a number of additional holes arranged in the edge portion of the guide body, so that it is possible, if necessary, to fix parts of fractured bone to the plate by means of sutures. The term 'edge portion' is to be understood here as referring to a zone not
15 exceeding 10 mm in width. These additional holes should suitably not have any sharp edges so as to prevent the sutures fixed therein from being damaged.

Suitably, the number of such additional holes is between 4 and 6, the hole diameter being between 1.5 and 2.5 mm.

20

According to a further preferred improvement of the invention, the guide body consists of a plurality of grids, preferably made of metal wire, which are stacked on one another and maintained in their relative position by a
25 frame, the superimposed meshes of the grids forming the openings. The Kirschner wires may be driven through the grid meshes at angles and in positions which are freely selectable and they are maintained in their relative positions by means of the wire grids stacked on one
30 another.

Preferably, the Kirschner wires are provided with a screw thread designed to engage with the wire grid so as to

prevent the wires from getting out of place. This improvement of the invention presents the advantage that the positions and the angles of the Kirschner wires are not predefined but may be freely selected according to the particularities of the fracture to be treated.

Preferably, 2 to 8 (typically 4 to 6) of such grids are stacked right on one another in order to achieve a minimal overall height of the implant. The mesh size of the grids preferably ranges between 1.5 and 2.0 mm and should generally be smaller than the diameter of the Kirschner wires which are used as fixation elements. The individual grids should be stacked in such a way that never two grids will have the same position (structure) relative to each other. The angle of twist between the individual grid layers will accordingly be defined by the number of grids used (e.g. 60 degrees with 6 grids). The wires forming the individual grids preferably have a thickness of between 0.2 and 0.6 mm.

The Kirschner wires used as fixation means are preferably provided with an external screw thread. At least part of the openings of the guide body should be provided with an internal screw thread corresponding to the external screw thread of the Kirschner wires. Preferably, the fixation element is provided with a headless rear end portion and has a uniform diameter over its entire length. On its front end portion, which may correspond to between ten and fifty percent of the total length, the fixation element is preferably provided with a non-threaded portion. The fixation element has a diameter ranging between 2 and 6 mm and the mesh size of the grids should be inferior to the diameter of the fixation element.

According to a preferred improvement of the invention, the fixation device including the guide body additionally comprises at least one hollow, cylindrical connecting piece provided with a concentric bore which is insertable into the openings of the guide body in such a way as to be in frictional or positive engagement therewith. The fixation element may be kept in place within the hollow, cylindrical connecting piece by means of press fit, force fit or friction.

In the following, the invention and improvements of the invention will be illustrated in greater detail with reference to the partially diagrammatic representations of several embodiments.

In the drawings:

Fig. 1 is a perspective representation of the guide body with Kirschner wires inserted therein;

Fig. 2 is a cross-sectional view of the guide body of Fig. 1 taken in the area of a Kirschner wire inserted therein;

Fig. 3 is a cross-sectional view of the guide body taken in the area of one of its openings including a threaded connecting piece insertable into said opening and a fixation means insertable into said connecting piece;

Fig. 4 is a cross-sectional view of the guide body taken in the area of one of its openings including a non-threaded connecting piece insertable into said

opening and a fixation means insertable into said connecting piece;

5 Fig. 5 is a perspective representation of a guide body consisting of a multilayer wire grid; and

Fig. 6 is a perspective representation of a guide body consisting of a multilayer wire grid and a lip for receiving a fastening screw.

10

The guide body shown in Fig. 1 consists of a flat or curved plate having a thickness of between 2 and 5 mm, made of metal materials suitable for implants or of plastic materials (including biodegradable plastic materials). The plate has a plurality of openings 2 realised in the form of bores which have a diameter of between 2 and 6 mm and which connect the top surface 3 with the bottom surface 4 of the guide body 1. The openings 2 are arranged in such a way that the centres of at least three of them are not situated on a straight line. The openings 2 serve for receiving surgical fixation elements 10 such as wires, nails, pegs or screws having a diameter of between 2 and 6 mm. In Fig. 1 these elements are Kirschner wires with an external screw thread 11 and a sharp front end 12. The central axes 5 of at least two of these openings 2 are skewed in relation to each other, so that the fixation means 10 may be three-dimensionally arranged. The central axes 5 of the openings 2 preferably form an angle of between 50 and 90 degrees relative to the plane of the plate-like guide body 1.

20

25

30 On the edge portion 7 of the guide body 1 six additional holes 8 are provided which have a diameter of 2 mm and serve for the fixation of sutures, as described below.

The bottom surface 4 of the guide body 1 is preferably adapted to the form of the bone surface to which it is to be applied in order to form a sufficiently large contact surface with the bone.

5

As shown in Fig. 2, the openings 2 shaped in the form of bores may be provided with an internal screw thread 6 which corresponds to the external screw thread 11 of the fixation means 10. Preferably, the fixation element 10 is provided with a headless rear end portion and thus has a uniform diameter over its entire length, which makes it possible to use conventionally shaped Kirschner wires. Furthermore, on its front end portion 12, which may correspond to between ten and fifty percent of the total length of the fixation element 10, said fixation element 10 is provided with a non-threaded portion. The screw thread is only necessary for the fastening of the fixation element 10 in the plate-like guide body 1, and not for its fixation in the bone.

Fig. 3 shows a preferred embodiment of a fixation device including a guide body 1 in which a hollow, cylindrical (or a hollow, conical) connecting piece 20 with a concentrical bore 21 is included which is insertable into the opening 2 in such a way as to be in frictional or positive engagement therewith. The connecting piece 20 may be inserted in a simple manner into the opening 2 where it will be retained by the force of friction, provided that it exactly fits the opening. It may, however, also be equipped with an external screw thread 22 which matches the internal screw thread 6 of the opening 2.

In this case, the fixation means 10, instead of being passed directly through the opening 2 may be passed through the concentrical bore 21 of the hollow, cylindrical

connecting piece 20. Inside the connecting piece 20, an internal screw thread 23 is provided which corresponds to the external screw thread 11 of the fixation means 10. The fixation means 10 may also be non-threaded and may be fastened within the guide body 1 merely by means of a radial clamping exerted by the connecting piece 20.

In another embodiment, shown in Fig. 4, the connecting piece 20 is realised in the form of a conical collet chuck or vice chuck which is insertable into a corresponding, conically shaped opening 2 of the guide body 1 in such a way as to be frictionally engaged, so that no screw threads are necessary.

The guide body 1 may be introduced into the patient's body through a minimal incision made for example in the region of the proximal humerus to which said guide body may be fastened by means of the fixation means 10. The additional use of bone cement as a reinforcement is not excluded. As the plate has a sufficient number of openings 2 as well as additional holes 8 located in the edge portion 7 of the guide body 1 the latter of which are specifically designed for fixing sutures thereto, these may serve for fastening bands to bone fragments of the humerus. The three-dimensional arrangement of the fixation means 10 prevents them from becoming loose, which results in a strongly improved overall stability of the fixation device.

In a further embodiment of the guide body 1, shown in Fig. 5 (realised here in the form of a guide plate), the fixation elements 10 are kept in place and stabilized in their respective angular positions by means of a multilayer mesh grid 31 held together by the frame 32. The fixation

elements 10 are driven directly through the multilayer grid 31. This may be done in any position all over the diameter defined by the individual openings 2. The lateral holes 34 arranged on the frame 32 may serve for fastening the guide body 1 by means of sutures.

The variant of the guide body 1 of Fig. 5 which is shown in Fig. 6 additionally comprises an elongate hole 33 in the form of a lip arranged on the frame 32 which might also be realised in the form of a normal, circularly cylindrical hole. It serves for receiving a screw (not shown in the drawing) by means of which the guide body 1 may be fastened to the bone before the fixation elements 10 are driven through the guide body 1 and sunk into the bone.

15

In the embodiments according to Figs. 5 and 6, the fixation elements 10 to be used (typically presenting the form of Kirschner wires) have an external screw thread in order to prevent them from being displaced.

Claims

1. A guide body (1) intended to receive longitudinal fixation elements (10) such as wires, nails, pegs or screws to be anchored within the bone, the guide body (1) being shaped in the form of a plate having a top surface (3), a bottom surface (4) intended for contact with the bone, and a number of openings (2) connecting the top surface (3) with the bottom surface (4) of the guide body (1),
- 5
- 10 **characterised in that**
- the openings (2) are arranged in such a way in the guide body (1) that at least two surgical fixation elements (10) may be inserted through the openings (2) and anchored within the bone in a skewed position relative to each
- 15 other.
2. A guide body (1) as claimed in claim 1, characterised in that the openings (2) are realised in the form of bores.
- 20 3. A guide body (1) as claimed in claim 1 or 2, characterised in that it is provided with at least three openings (2) which connect the top surface (3) with the bottom surface (4) of the guide body and the centres of which are not situated on a straight line.
- 25
4. A guide body (1) as claimed in any of the claims 1 to 3, characterised in that at least two of the openings (2) have central axes (5) which are skewed in relation to each other.
- 30
5. A guide body (1) as claimed in any of the claims 1 to 4, characterised in that at least one of the openings (2) is provided with an internal screw thread (6).

6. A guide body (1) as claimed in any of the claims 1 to 5, characterised in that the openings (2) have a diameter ranging between 2 and 6 mm.

5

7. A guide body (1) as claimed in any of the claims 1 to 6, characterised in that in the area of the edge portion (7) of the guide body (1) a number of additional holes (8) is included which preferably have a diameter smaller than that of the openings (2).

10

8. A guide body (1) as claimed in claim 7, characterised in that the number of additional holes (8) is between four and six.

15

9. A guide body (1) as claimed in claim 7 or 8, characterised in that the diameter of the additional holes (8) is between 1.5 and 2.5 mm.

20

10. A guide body (1) as claimed in any of the claims 1 to 9, characterised in that it consists of a plurality of grids (31) stacked on one another which are maintained in their relative positions by means of a frame (32) and the superimposed meshes of which form the openings (2).

25

11. A guide body (1) as claimed in claim 10, characterised in that the number n of the superimposed grids (31) is within a range of $2 < n < 8$, preferably $4 < n < 6$.

30

12. A guide body (1) as claimed in claim 10 or 11, characterised in that the mesh size of the grids (31) ranges between 1.5 and 2.0 mm.

13. A guide body (1) as claimed in any of the claims 10 to 12, characterised in that the individual grids (31) are in a twisted arrangement relative to one another.

5 14. A guide body (1) as claimed in any of the claims 10 to 13, characterised in that the wires forming the individual grids (31) have a thickness of between 0.2 and 0.6 mm.

15. A fixation device for bone surgery including a guide
10 body as claimed in any of the claims 1 to 14,

characterised in that

it comprises at least one fixation element (10).

16. A fixation device as claimed in claim 15, characterised
15 in that the fixation element (10) is provided with an external screw thread (11).

17. A fixation device as claimed in claim 16, characterised
in that at least part of the openings (2) are provided with
20 an internal screw thread (6) which corresponds to said external screw thread (11).

18. A fixation device as claimed in any of the claims 15 to
17, characterised in that the fixation element (10) is
25 provided with a headless rear end portion.

19. A fixation device as claimed in any of the claims 15 to
18, characterised in that the fixation element (10) has a
uniform diameter over its entire length.

30

20. A fixation device as claimed in any of the claims 15 to
19, characterised in that on its front end portion (12) the

fixation element (10) is provided with a non-threaded portion.

21. A fixation device as claimed in claim 20, characterised
5 in that said front end portion (12) corresponds to between
ten and fifty percent of the total length of the fixation
element (10).

22. A fixation device as claimed in any of the claims 15 to
10 21, characterised in that the fixation element (10) has a
diameter ranging between 2 and 6 mm.

23. A fixation device as claimed in any of the claims 15 to
15 22, characterised in that the mesh size of the grids (31)
is smaller than the diameter of the fixation element (10).

24. A fixation device for bone surgery including a guide
body (1) as claimed in any of the claims 1 to 14,
characterised in that

20 it includes at least one hollow, cylindrical connecting
piece (20) with a concentric bore (21) which is
insertable into the openings (2) of the guide body (1) in
such a way as to be in frictional or positive engagement
therewith.

25

25. A fixation device as claimed in claim 24 and in any of
the claims 15 to 23.

26. A fixation device as claimed in claim 24 or 25,
30 characterised in that the fixation element (10) may be kept
in place within the hollow, cylindrical connecting piece
(20) by means of press fit, force fit or friction.

Fig. 1 1/3

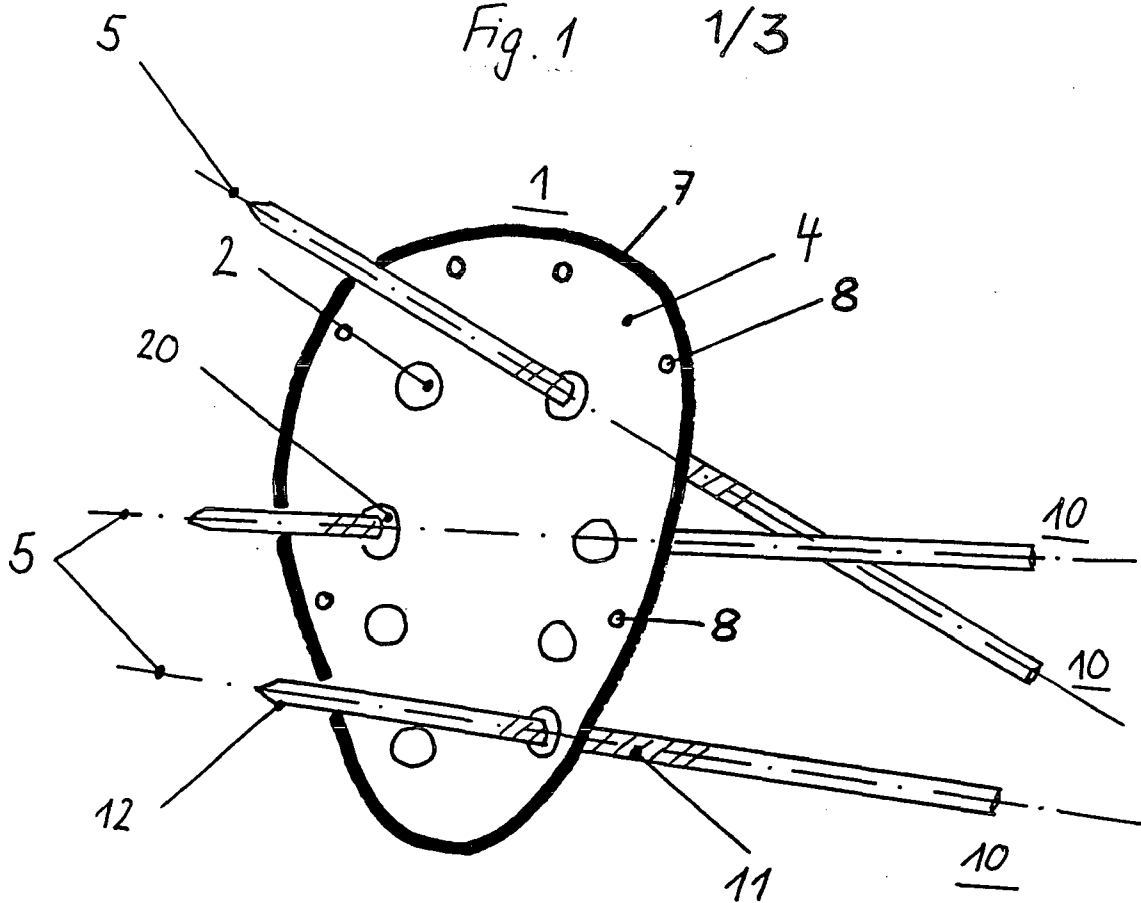
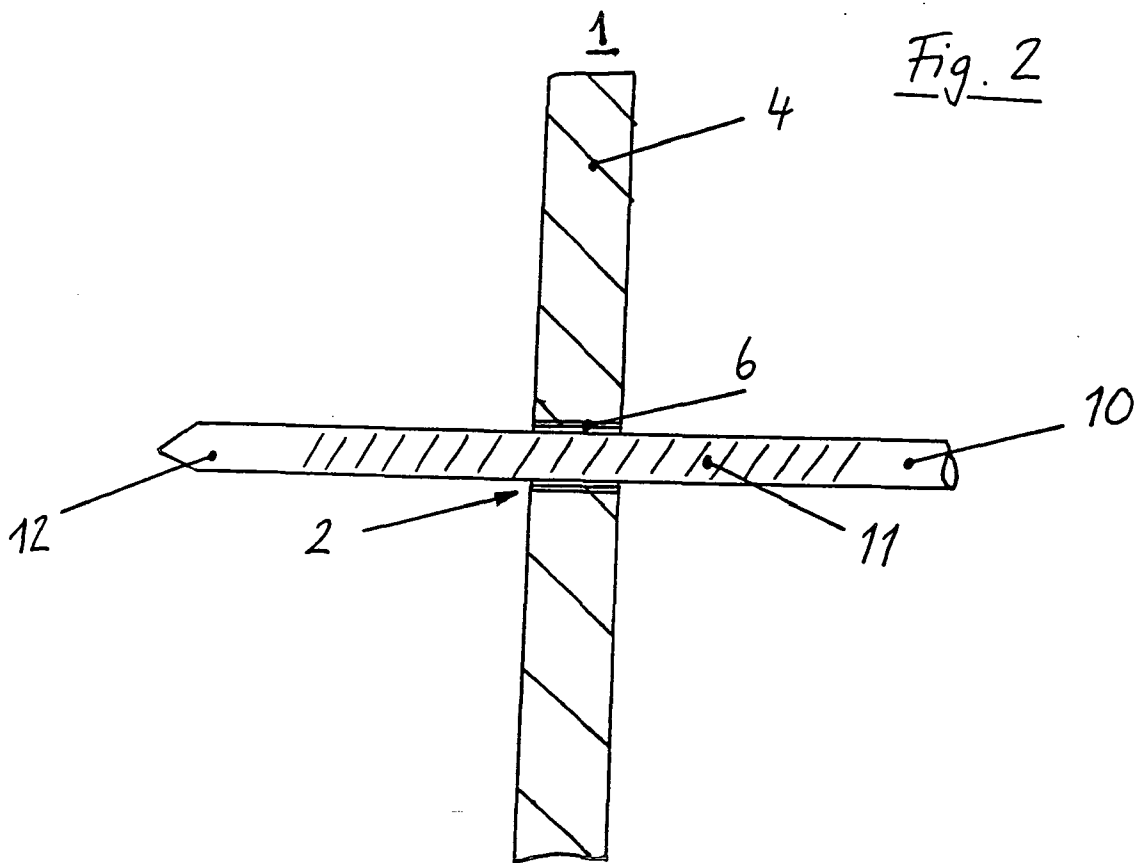

Fig. 2



2/3

Fig. 3

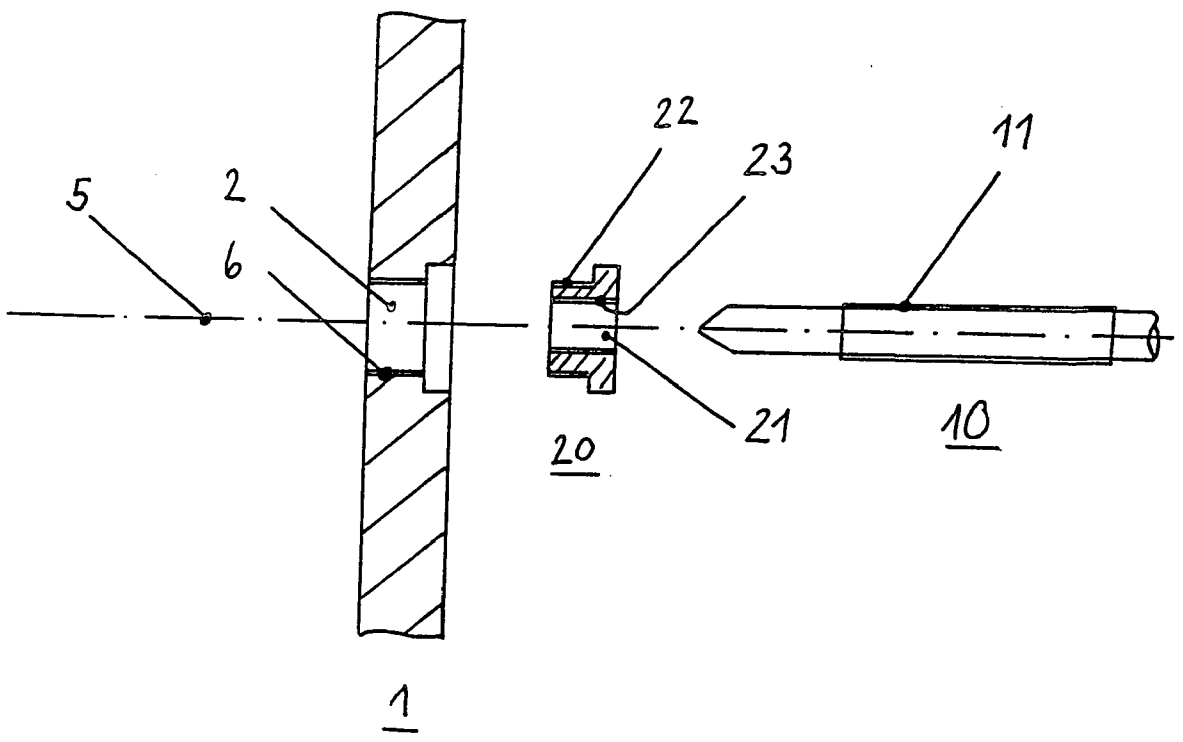

Fig. 4

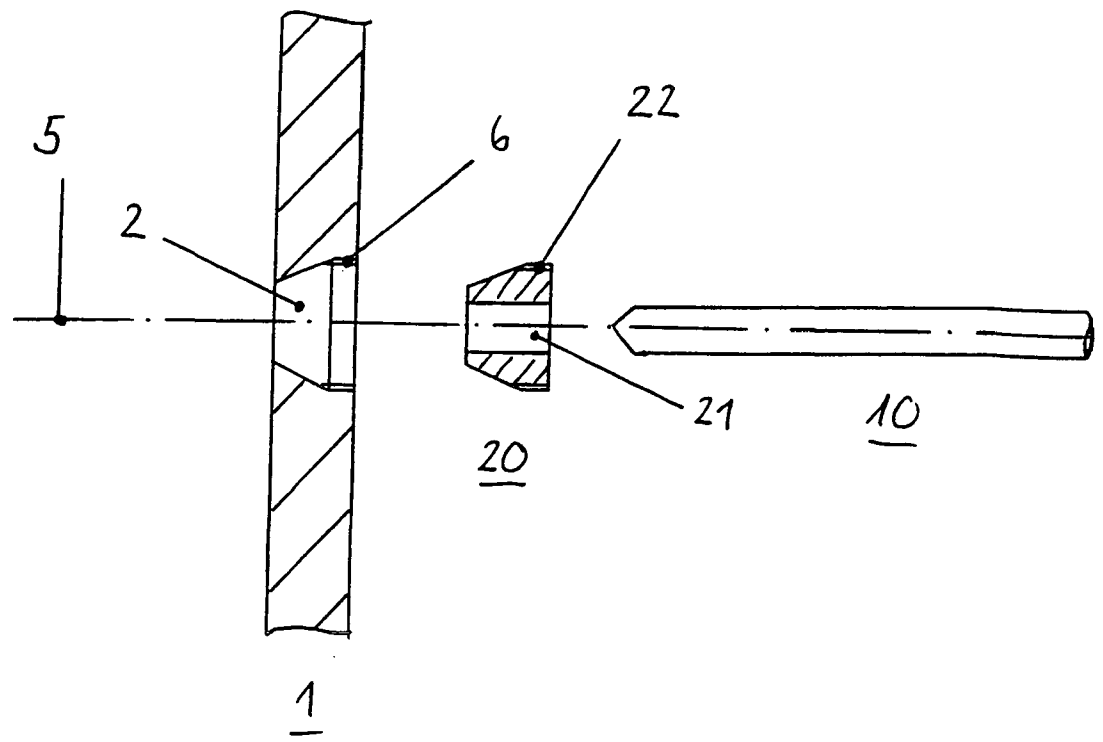

Fig. 6

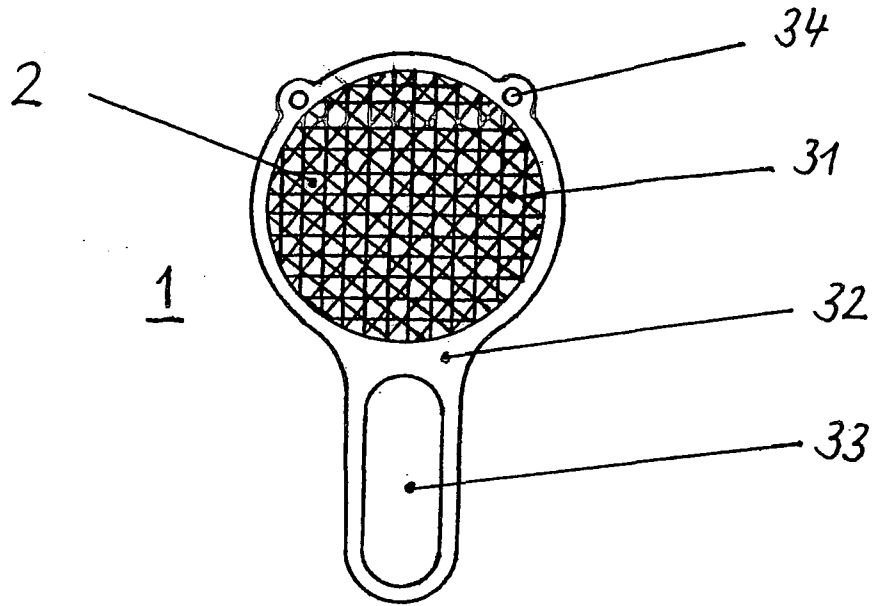

Fig. 5

