



AU9349554

**(12) PATENT ABRIDGMENT (11) Document No. AU-B-49554/93**  
**(19) AUSTRALIAN PATENT OFFICE (10) Acceptance No. 678998**

- (54) Title  
**COSMETIC COMPOSITION CONTAINING RETINOL**
- International Patent Classification(s)  
 (51)<sup>5</sup> **A61K 007/42 A61K 007/48**
- (21) Application No. : **49554/93** (22) Application Date : **30.08.93**
- (87) PCT Publication Number : **WO94/07462**
- (30) Priority Data
- (31) Number (32) Date (33) Country  
**9220670 30.09.92 GB UNITED KINGDOM**
- (43) Publication Date : **26.04.94**
- (44) Publication Date of Accepted Application : **19.06.97**
- (71) Applicant(s)  
**UNILEVER PLC**
- (72) Inventor(s)  
**CLIVE RODERICK HARDING; CAROLINE MARIAN LEE; IAN RICHARD SCOTT**
- (74) Attorney or Agent  
**UNILEVER AUSTRALIA LIMITED , B F Jones, Private Mailbag 2, EPPING NSW 2121**
- (56) Prior Art Documents  
**AU 48283/93**  
**US 5002760**  
**EP 297436**

## (57) Claim

1. A composition suitable for topical application to human skin in order to promote repair of photo-damaged skin and/or to reduce or prevent the damaging effects of ultra-violet light on skin, and/or to lighten the skin, which composition comprises:

i) an effective amount of from 0.01 to 10% by weight of retinol or a derivative thereof having the structure

(1)

:

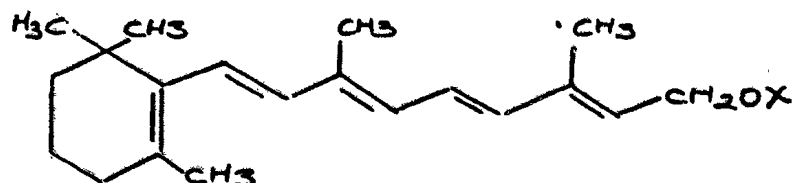

(1)

where X represents H or  $-COR^1$  where  $R^1$  represents a group chosen from branched or unbranched, alkyl or alkenyl

(11) AU-B-49554/93

-2-

(10) 678998

groups having an average of from 1 to 20 carbon atoms;

- ii) an effective amount of from 0.1 to 30% by weight of a dioic acid having the general structure (2)



where a is an integer of from 6 to 20

and b is an integer of from 8 to 40; and

- iii) a cosmetically acceptable vehicle.

OPI DATE 26/04/94 APPLN. ID 49554/93  
AOJP DATE 14/07/94 PCT NUMBER PCT/EP93/02341



AU9349554

INTERNATIONAL APPLICATION PUBLISHED UNDER THE PATENT COOPERATION TREATY (PCT)

<p>(51) International Patent Classification <sup>5</sup> : <b>A61K 7/48, 7/42</b></p>	<p><b>A1</b></p>	<p>(11) International Publication Number: <b>WO 94/07462</b> (43) International Publication Date: 14 April 1994 (14.04.94)</p>
<p>(21) International Application Number: PCT/EP93/02341 (22) International Filing Date: 30 August 1993 (30.08.93) (30) Priority data: 9220070.5 30 September 1992 (30.09.92) GB (71) Applicant (for AU BB CA GB IE LK MN MW NZ SD only): UNILEVER PLC [GB/GB]; Unilever House, Blackfriars, London EC4P 4BQ (GB). (71) Applicant (for all designated States except AU BB CA GB IE LK MN MW NZ SD): UNILEVER NV [GB/GB]; Weena 455, NL-3013 Al Rotterdam (GB). (72) Inventors: HARDING, Clive, Roderick ; 25 Rushmerer Way, Rushden, Northampton NN10 6YB (GB). LEE, Caroline, Marian ; 11 Crayton Road, Ampthill, Bedford MK45 2LE (GB). SCOTT, Ian, Richard ; 69 Arcadia Road, Allandale, NJ 07401 (US).</p>	<p>(74) Agent: TONGE, Robert, James; Unilever plc, Patent Division, Colworth House, Sharnbrook, Bedford MK44 1LQ (GB). (81) Designated States: AT, AU, BB, BG, BR, BY, CA, CH, CZ, DE, DK, ES, FI, GB, HU, JP, KP, KR, KZ, LK, LU, MG, MN, MW, NL, NO, NZ, PL, PT, RO, RU, SD, SE, SK, UA, VN, European patent (AT, BE, CH, DE, DK, ES, FR, GB, GR, IE, IT, LU, MC, NL, PT, SE), OAPI patent (BF, BJ, CF, CG, CI, CM, GA, GN, ML, MR, NE, SN, TD, TG). <b>Published</b> <i>With international search report.</i></p> <p><b>678998</b></p>	
<p>(54) Title: COSMETIC COMPOSITION CONTAINING RETINOL</p>		
<p>(57) Abstract</p> <p>A composition for topical application to human skin in order to promote the repair of photo-damaged skin and/or to reduce or prevent the damaging effects of ultra-violet light on skin and/or to lighten the skin comprising retinol or a derivative thereof and a dioic acid.</p>		

## COSMETIC COMPOSITION CONTAINING RETINOL

FIELD OF INVENTION

5 The invention relates to a composition for topical application to human skin in order to promote the repair of photo-damaged skin and/or to reduce or prevent the damaging effects of ultra-violet light on skin and/or to lighten the skin. The invention also relates to the use of such  
10 compositions in the repair of photo-damaged skin and in the prevention of damage to skin due to exposure to ultra-violet light.

BACKGROUND TO THE INVENTION

15 The treatment of human skin damaged due to exposure to ultra-violet light, ie photo-damaged, has been subject to much research effort in recent years, particularly with the realisation that skin cancer and other skin disorders can  
20 arise where the exposure to sunlight is excessive. This problem is even more serious with the depletion of the ozone layer which is believed to permit a higher level of ultra-violet radiation to reach the earth's surface.

25 Chronic exposure to sunlight results in multiple adverse effects on all structural elements of the skin. The clinical manifestation of these changes, collectively known as photoageing is lax, dry inelastic skin that is wrinkled and blotchy with a coarse, roughened texture.

30 Skin blotchiness or mottling (hyperpigmentation) is due to changes in the melanocytes within the population of epidermal cells. These pigment-producing cells, which unlike the keratinocytes remain at the base of the  
35 epidermis, lose their normal regulation process with ageing and produce excess pigment. This leads to the formation of dense perinuclear clumps of melanin in slowly turning-over

keratinocytes within the epidermis, and areas of hyperpigmentation or "age spots" develop.

5 In the therapy of such hyperpigmented skin, azelaic acid is known as a skin lightening agent which is effective by inhibiting the formation of melanin. Vitamin A acid (retinoic acid) is beneficial in hyperpigmentation problems (Bulengo-Ransby S M et al (1993) New England Journal of Medicine pp 1438-1443).

10

Also, by increasing cell turnover Vitamin A acid prevents accumulation of pigment within the more rapidly dividing and migrating keratinocytes. Vitamin A acid also enhances the pigment-reducing potential of conventional skin

15

The topical application of Vitamin A acid does however have a major drawback in that it is a skin irritant, and can accordingly damage the skin. Its recommended use for

20

example as a prescription drug in the treatment of acne involves careful control, such that excessive doses are avoided in order to restrict the side effects which can occur with skin. By the same token, the use of Vitamin A acid in the treatment or prevention of photo-damaged skin

25

We have now discovered that retinol or certain derivatives thereof, when combined with certain saturated or unsaturated dioic acids can be used effectively in the

30

repair of photo-damaged skin or the prevention of photo-damage to skin following exposure to ultra-violet light. This combination is also particularly useful in reducing hyperpigmentation of skin or to lighten the skin.

DEFINITION OF THE INVENTION

Accordingly, the invention provides a composition suitable for topical application to human skin in order to promote repair of photo-damaged skin and/or to reduce or prevent the damaging effects of ultra-violet light on skin, and/or to lighten the skin, which composition comprises:

- i) an effective amount of from 0.01 to 10% by weight of retinol or a derivative thereof having the structure (1):

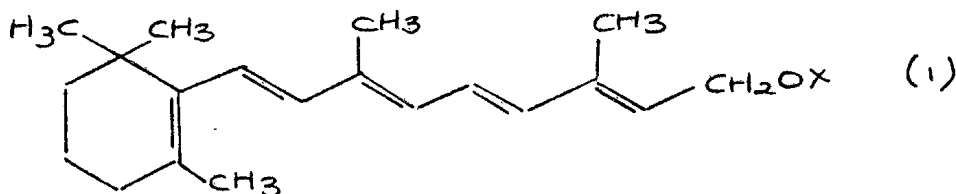

where X represents H or -COR<sup>1</sup> where R<sup>1</sup> represents a group chosen from branched or unbranched, alkyl or alkenyl groups having an average from 1 to 20 carbon atoms; and

- ii) an effective amount of from 0.1 to 30% by weight of a dioic acid having the general structure (2)



where a is an integer of from 6 to 20  
and b is an integer of from 8 to 40

The invention further provides a method of reducing or preventing the damaging effects of ultra-violet light on skin and/or of lightening the skin which method includes the topical application of composition comprising:

- i) an effective amount of from 0.01 to 10% by weight of retinol or a derivative thereof having the structure (1):

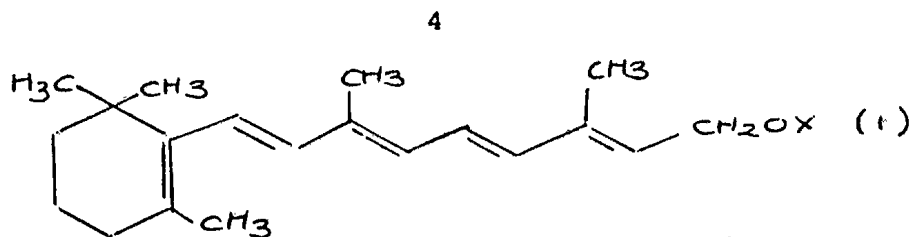

5 where X represents H or  $-\text{COR}^1$  where  $\text{R}^1$  represents a group chosen from branched or unbranched, alkyl or alkenyl groups having an average from 1 to 20 carbon atoms; and

10 ii) an effective amount of from 0.1 to 30% by weight of a dioic acid having the general structure (2)

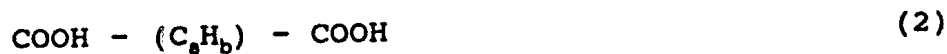

15 where a is an integer of from 6 to 20  
and b is an integer of from 8 to 40

#### DISCLOSURE OF THE INVENTION

20 The invention concerns a composition comprising retinol or a derivative thereof together with a dioic acid having the general structure (2) which together behave synergistically in reducing skin blotchiness and mottling due to hyperpigmentation. Furthermore, due to the rejuvenating  
25 influence of the retinol or its derivative on skin, there will be an overall improvement in skin texture with reduction in fine wrinkling and improved skin colour. Also, co-formulation with a sunscreen will enhance the photo-stability and activity of retinol or its derivative  
30 within the formulation and also prevent further actinic damage to all epidermal cells.

#### Retinol and derivatives thereof

35 The composition according to the invention comprises retinol or a derivative thereof having the structure (1).

In addition to retinol itself, examples of derivatives of retinol include:

5           Retinyl acetate  
          Retinyl butyrate  
          Retinyl propionate  
          Retinyl octanoate  
          Retinyl laurate  
          Retinyl palmitate  
10          Retinyl oleate  
          Retinyl linoleate

15          The amount of retinol, or a derivative thereof, present in the composition according to the invention is from 0.01 to 10% and preferably 0.05 to 5% by weight of the composition, most preferably 0.05 to 1% by weight of the composition.

20          Preferably the composition comprises retinol, most preferable the composition comprises the trans-isomer of retinol.

#### The Dioic Acid

25          The composition according to the invention also comprises a dioic acid having the general structure (2).

          The dioic acid is selected from  $C_8-C_{22}$  mono- and di-unsaturated dioic acids and  $C_8-C_{22}$  saturated dioic acids.

30          Preferably the dioic acid is selected from  $C_{9-18}$  saturated, mono- and di-unsaturated dioic acids and mixtures thereof.

35          The amount of dioic acid which is present in the composition according to the invention is from 0.1 to 30%, preferably from 1 to 25% by weight of the composition, even more preferably from 5 to 20% by weight of the composition.



$C_8$  -  $C_{16}$  saturated dioic acids are available commercially from chemical suppliers.

5  $C_{17}$  -  $C_{22}$  saturated or unsaturated dioic acids while not commercially available can be manufactured by fermentation using non-chain shortening Candida yeast  $\beta$ -oxidation mutants. Saturated or unsaturated hydrocarbons, aldehydes, alcohols or monocarboxylic acids are converted to the  
10 corresponding chain length dicarboxylic acid by the oxidative action of the mutant yeast. The production and isolation of  $\beta$ -oxidation mutant Candida yeasts and their use for the production of dicarboxylic acids by fermentation has been described in Casey J, Dobb R and Mycock G (1990), J Gen Microbiol, 136, 1197-1202; and  
15 Buhler M and Schindler J (1984) in Biotechnology, Volume 6, edited by Rehm H J and Reed G, Verlag Chemie, Weinheim, pp 229-385.

20 Furthermore we have discovered that  $C_8$  -  $C_{16}$  unsaturated dioic acids may be produced using the method disclosed in EP 341 796. Further detail of this production is provided below.

25 The unsaturated dioic acids are conveniently produced by biochemical oxidation of non-toxic levels of unsaturated fatty acids using a yeast propagated in a carbon substrate-containing growth medium.

30 Yeasts suitable for the purpose are disclosed in EP 0341796 and in Casey et al., (1990) Journal of General Microbiology 136, 1197-1202. Such strains (eg Candida cloacae 5GLA12, abbreviated to "LA12") exhibit no (or very low levels of) beta-oxidation activity.

35 Conveniently the yeasts are supplied with unsaturated fatty acids in the form of esters, preferably as triglyceride esters such as oil. Particularly suitable examples include

unsaturated oils such as sunflower oil and olive oil, treated to remove free fatty acids.

Preferably the oils used as starting materials are triglycerides in which the predominant unsaturated long chain fatty acid is a C<sub>18</sub> compound. Fermentation by yeast strains such as LA12 can result in the production of mixtures of chain-shortened, unsaturated dioic acids typically C<sub>8</sub> to C<sub>16</sub> compounds. These mixed products can be separated into fractions, for example by differential solvent extraction.

If one assumes that there is random removal of C<sub>2</sub> units during beta-oxidation, and that no isomerisation of the products occurs, the following products may be predicted to be formed when using oleic acid as a substrate:

cis-7-hexadecene dioic acid; cis-5-tetradecene dioic acid; cis-7-tetradecene dioic acid; cis-3-dodecene dioic acid; cis-5-dodecene dioic acid; cis-3-decene dioic acid; cis-5-decene dioic acid and cis-3-octene dioic acid.

From linoleic acid, the following products may be expected:

cis-6, 9-hexadecadiene dioic acid; cis-4, 7-hexadecadiene dioic acid; cis-5, 8-tetracadiene dioic acid; cis-4, 7-tetracadiene dioic acid; cis-3, 6-dodecadiene dioic acid; cis-2, 5-tetradecadiene dioic acid; cis-4, 7-dodecadiene dioic acid; cis-3, 6-decadiene dioic acid; cis-2, 5-decadiene dioic acid; cis-2, 5-dodecadiene dioic acid; cis-2, 5-octadiene dioic acid; cis-4-decene dioic acid and cis-2-octene dioic acid.

Likewise the predicted products using linolenic acid as a starting material are as follows:

cis-4, 7, 10-hexadecatriene dioic acid; cis-6, 9, 12-hexadecatriene dioic acid; cis-2, 5, 8-tetradecatriene dioic acid; cis-4, 7, 10-tetradecatriene dioic acid; cis-2, 5, 8-dodecatriene dioic acid; cis-3, 6-dodecadiene dioic acid; cis-2, 5, 8-decatriene dioic acid; cis-3, 6-decadiene dioic acid; cis-4-decene dioic acid; cis-2, 5-octadiene dioic acid; cis-4-octene dioic acid and cis-2-octene dioic acid.

10 There is a reason to believe that, in each case, a wider range of products may be formed than those predicted. This is because there is evidence to suggest that isomerism of these compounds does occur (Osmundsen & Hovik, 1988, Biochemical Society Transactions 16, 420-422).

15 Naturally, where trans-unsaturated compounds are the starting compounds, trans-unsaturated products will result.

20 Some of the products of these fermentations have been extensively characterised. For instance, nuclear magnetic resonance (NMR) spectroscopy has been used to determine the structure of the C<sub>12</sub> mono-unsaturated dioic acid derived from olive oil. The compound is substantially pure (ie no other isomeric forms are readily apparent) cis-5-dodecene  
25 dioic acid.

30 It is a highly preferred feature that the yeast employed for the process is not propagated under conditions of nitrogen limitation. Instead, the yeast is grown under conditions which are comparatively enriched for nitrogen, wherein alteration of pH affects the chain shortening  $\beta$ -oxidation activity of the organism.

35 Thus, it is found that the product profile of the fermentation process may conveniently be modified by alteration of the pH of the fermentation medium during the production of unsaturated dioic acids. In particular, it is possible to alter the relative concentrations of the

different lengths of dioic acid molecules in this way. For example, by reducing the pH from 7.5 to 7.1 during fermentation of olive oil, it is possible to increase the relative amount of the C<sub>12</sub> unsaturated dioic acid.

5

This is significant because certain fractions of the fermentation products may have especially advantageous properties for particular intended uses. For example, the C<sub>12</sub>-C<sub>14</sub> fraction obtained from the fermentation of olive oil is particularly active in inhibiting the growth of Propionibacterium acnes, whilst the C<sub>8</sub>-C<sub>10</sub> fraction obtained from the fermentation of sunflower oil is particularly active as a general anti-microbial agent. The different fractions of different products may be obtained from the culture medium by extracting with diethyl ether at different acidic pHs.

10

15

20

Specific example of novel unsaturated dioic acid production: Production of medium chain unsaturated dioic acids by fermentation

25

A beta-oxidation mutant of Candida cloacae produced by mutagenesis using nitrosoguanidine (mutant LA12, see EP0341796 and see also Casey et al, J Gen Microbiol (1990), 136, 1197-1202) was used to produce C<sub>8</sub>-C<sub>14</sub> unsaturated dioic acids from triglycerides such as olive oil and sunflower oil which contain high levels of unsaturated fatty acids.

30

A chemically defined medium was used as shown below:

35

Sucrose	20g/l	)	
(NH <sub>4</sub> ) <sub>2</sub> HPO <sub>4</sub>	6g/l	)	
KH <sub>2</sub> PO <sub>4</sub>	6.4g/l	)	
Na <sub>2</sub> SO <sub>4</sub>	1.5g/l	)	autoclave 20
Triglyceride	10-40ml/l	)	mins at 121°C
(eg olive oil or sunflower oil)		)	

10

	ZnSO <sub>4</sub> .7H <sub>2</sub> O	20mg/l	)	
	MnSO <sub>4</sub> .4H <sub>2</sub> O	20mg/l	)	
	FeSO <sub>4</sub> .7H <sub>2</sub> O	20mg/l	)	
	MgCl <sub>2</sub> .6H <sub>2</sub> O	2g/l	)	filter sterilise
5	Biotin	100mg/l	)	and add aseptically
	Pantothenate	6mg/l	)	when fermenter cool
	Thiamine	8mg/l	)	
	Nicotinic acid	30mg/l	)	
	Pyridoxine	20mg/l)		

10

The fermenter conditions were:

	Growth pH:	6.8	)	maintained by
	Production pH:	7.4-7.5	)	auto-addition of
15	Temperature:	30°C	)	10M NaOH
	Aeration:	0.1 v/v/m air		
	Impeller speed:	800-1000 rpm		
	Fermenter volume:	2.5L		
	Inoculum:	2%		
20	Fermenter type:	LSL fitted with foam breaker		

The medium (2.5l) was inoculated with 2% (v/v) of a 24 hr culture of Candida cloacae beta-oxidation mutant LA12 grown on yeast extract (5g/l/sucrose (10g/l), peptone 5g/l) medium. The culture was grown for 20 hr at pH 6.8 then 20 ml/l of oil was added and the pH increased to 7.4-7.6 to initiate production of the medium chain unsaturated dioic acids. The oil was either sunflower oil or silica-purified olive oil. During production of the dioic acids, the RQ (respiratory quotient) value fell to about 0.6. Aliquots (10-20ml) of fermenter broth were removed daily for lipid analysis and additional oil was added as required.

The fermentation was harvested when production ceased at 8-12 days.

35

Medium chain unsaturated dioic acids were isolated from fermenter broths by acidification to pH 6 with HCl then extraction with diethyl ether to isolate a C<sub>12</sub>-C<sub>14</sub> rich fraction. The broth was then further acidified with HCl to about pH 2.0 and further extracted with diethyl ether to isolate a C<sub>8</sub>-C<sub>10</sub> rich fraction. For isolation of the mixed acids the broth pH was decreased from 7.5 to about 2.0 in one step then extracted with diethyl ether. Solvent was removed from the dioic acid fractions by rotary evaporation.

#### Specific example of use of pH to alter dioic acid production profile

At a production pH of 7.4-7.6 the dominant species from oils (eg olive oil) containing C<sub>18</sub> unsaturated fatty acids is the C<sub>14</sub> unsaturated dioic acid.

However, if the production pH is decreased from 7.4-7.6 to around 7.1, the C<sub>12</sub> unsaturated dioic acid becomes the dominant species. Fermentation was performed as detailed in the above examples until fermentation day 8 when the pH was dropped to 7.1 resulting in 'turn-over' of the C<sub>14</sub> species and an increase in C<sub>12</sub> production.

#### The Cosmetically Acceptable Vehicle

The composition according to the invention also comprises a cosmetically acceptable vehicle to act as a diluent, dispersant or carrier for other materials present in the composition, so as to facilitate their distribution when the composition is applied to the skin.

Vehicles other than water can include liquid or solid emollients, solvents, humectants, thickeners and powders. Examples of each of these types of vehicle, which can be used singly or as mixtures of one or more vehicles, are as

follows:

Emollients, such as stearyl alcohol, glyceryl monoricinoleate, mink oil, cetyl alcohol, isopropyl isostearate, stearic acid, isobutyl palmitate, isocetyl stearate, oleyl alcohol, isopropyl laurate, hexyl laurate, decyl oleate, octadecan-2-ol, isocetyl alcohol, eicosanyl alcohol, behenyl alcohol, cetyl palmitate, silicone oils such as dimethylpolysiloxane, di-n-butyl sebacate, isopropyl myristate, isopropyl palmitate, isopropyl stearate, butyl stearate, polyethylene glycol, triethylene glycol, lanolin, cocoa butter, corn oil, cotton seed oil, olive oil, palm kernel oil, rapeseed oil, safflower seed oil, evening primrose oil, soybean oil, sunflower seed oil, avocado oil, sesame seed oil, coconut oil, arachis oil, castor oil, acetylated lanolin alcohols, petroleum jelly, mineral oil, butyl myristate, isostearic acid, palmitic acid, isopropyl linoleate, lauryl lactate, myristyl lactate, decyl oleate, myristyl myristate;

Propellants, such as air, propane, butane, isobutane, dimethyl ether, carbon dioxide, nitrous oxide;

Solvents, such as ethyl alcohol, isopropanol, acetone, ethylene glycol monoethyl ether, diethylene glycol monobutyl ether, diethylene glycol monoethyl ether;

Powders, such as chalk, talc, fuller's earth, kaolin, starch, gums, colloidal silica sodium polyacrylate, tetra alkyl and/or trialkyl aryl ammonium smectites, chemically modified magnesium aluminium silicate, organically modified montmorillonite clay, hydrated aluminium silicate, fumed silica, carboxyvinyl polymer, sodium carboxymethyl cellulose, ethylene glycol monostearate.

The cosmetically acceptable vehicle will usually form from 10 to 99.9%, preferably from 50 to 99% by weight of the

emulsion, and can, in the absence of other cosmetic adjuncts, form the balance of the emulsion.

Organic sunscreens

5

The composition of the invention optionally can comprise an organic sunscreen further to enhance the benefit of the composition in providing protection from the harmful effects of excessive exposure to sunlight.

10

Examples of suitable organic sunscreens, when required, include those set out in Table 1 below, and mixtures thereof.

15

TABLE 1

	CTFA Name	Trade Name	Supplier
20	Benzophenone-3	UVINUL M-40	BASF Chemical Co
	Benzophenone-4	UVINUL MS-40	BASF Chemical Co
	Benzophenone-8 DEA	SPECTRA-SORB UV-24	American Cyanamide
	Methoxycinnamate	BERNEL HYDRO	Bernal Chemical
25	Ethyl dihydroxy- propyl-PABA	AMERSCREEN P	Amerchol Corp
	Glyceryl PABA	NIPA GMPA	Nipa Labs
	Homosalate	KEMESTER HMS	Hunko Chemical
	Methyl anthranilate	SUNAROME UVA	Felton Worldwide
30	Octocrylene	UVINUL N-539	BASF Chemical Co
	Octyl dimethyl PABA	AMERSCOL	Amerchol Corp
	Octyl methoxy- cinnamate	PARSOL MCX	Bernal Chemical
	Octyl salicylate	SUNAROME WMO	Felton Worldwide
35	PABA	PABA	National Starch
	2-Phenyl- benzimidazole- -5-sulphonic acid	EUSOLEX 232	EM Industries



	TEA salicylate	SUNAROME W	Felton Worldwide
	3-(4-methylbenzy- lidene)-camphor	EUSOLEX 6300	Em Industries
	Benzophenone-1	UVINUL 400	BASF Chemical Co
5	Benzophenone-2	UVINUL D-50	BASF Chemical Co
	Benzophenone-6	UVINUL D-49	BASF Chemical Co
	Benzophenone-12	UVINUL 408	BASF Chemical Co
	4-Isopropyl dibenzoyl methane	EUSOLEX 8020	EM Industries
10	Butyl methoxy di- benzoyl methane	PARSOL 1789	Givaudan Corp
	Etocrylene	UVINUL N-35	BASF Chemical Co

15 The composition of the invention can accordingly comprise from 0.1 to 10%, preferably from 1 to 5% by weight of an organic sunscreen material.

#### Inorganic sunscreen

20 The composition according to the invention optionally can also comprise as a sunscreen ultrafine titanium dioxide in either of two forms, namely water-dispersible titanium dioxide and oil-dispersible titanium dioxide.

25 Water-dispersible titanium dioxide is ultrafine titanium dioxide, the particles of which are uncoated or which are coated with a material to impart a hydrophilic surface property to the particles. Examples of such materials include aluminium oxide and aluminium silicate.

30 Oil-dispersible titanium dioxide is ultrafine titanium dioxide, the particles of which exhibit a hydrophobic surface property, and which, for this purpose, can be coated with metal soaps such as aluminium stearate,  
35 aluminium laurate or zinc stearate, or with organosilicone compounds.

By "ultrafine titanium dioxide" is meant particles of titanium dioxide having an average particle size of less than 100nm, preferably from 10 to 40nm and most preferably from 15 to 25nm.

5

By topical application to the skin of a mixture of both water-dispersible ultrafine titanium dioxide and oil-dispersible ultrafine titanium dioxide, synergically enhanced protection of the skin against the harmful effects of both UV-A and UV-B rays is achievable.

10

It is believed that this unexpected benefit is due to the deposition of each type of titanium dioxide on different regions of the skin surface, water-dispersible titanium dioxide being preferentially retained by hydrophilic regions of the skin's surface, while oil-dispersible titanium dioxide is retained preferentially by hydrophobic regions of the skin's surface. The combined overall effect is that more efficient physical coverage of the skin's surface is attainable and this can be demonstrated by measurement of the Sun Protection Factor (SPF).

15

20

In order to achieve the enhanced, synergistic benefit, as herein described, the weight ratio of water-dispersible titanium dioxide to oil-dispersible titanium dioxide should be from 1:4 to 4:1, preferably from 1:2 to 2:1 and ideally about equal weight proportions.

25

The total amount of titanium dioxide that can optionally can be incorporated in the composition according to the invention is from 1 to 25%, preferably from 2 to 10% and ideally from 3 to 7% by weight of the composition.

30

Other Inorganic Sunscreens

The emulsion of the invention optionally can comprise an inorganic sunscreen in addition to ultrafine titanium dioxide as herein defined.

Examples of other inorganic sunscreens include:

zinc oxide, having an average particle size of  
from 1 to 300nm,

iron oxide, having an average particle size of  
from 1 to 300nm,

silica, such as fumed silica, having an average  
particle size of from 1 to 100nm.

It should be noted that silica, when used as an ingredient in the emulsion according to the invention can provide protection from infra-red radiation.

Other skin-whitening agents

Compositions according to the invention may also optionally comprise other skin whitening agents.

Examples of skin-lightening agents include:

L-ascorbic acid, and derivatives thereof  
Kojic acid, and derivatives thereof  
Hydroquinone  
Extract of placenta  
Arbutin  
Niacin  
Niacinamide, and  
Compounds having the structure (3)



where R<sup>1</sup> represents H, or an ether group represented by OR<sup>3</sup>,

10 R<sup>2</sup> and R<sup>3</sup> are the same or different and each represents a group chosen from branched or unbranched alkyl or alkenyl groups having an average of from 1 to 20 carbon atoms.

#### OPTIONAL SKIN BENEFIT MATERIALS AND COSMETIC ADJUNCTS

15 A particularly convenient form of the composition according to the invention is an emulsion, in which case an oil or oily material will normally be present, together with an emulsifier to provide either a water-in-oil emulsion or an  
20 oil-in-water emulsion, depending largely on the average hydrophilic-lipophilic balance (HLB) of the emulsifier employed.

#### Oil or oily material

25 The composition according to the invention can optionally comprise one or more oils or other materials having the properties of an oil.

30 Examples of suitable oils include mineral oil and vegetable oils, and oil materials, such as those already proposed herein as emollients. Other oils or oily materials include silicone oils, both volatile and non-volatile, such as polydimethyl siloxanes.

35 The oil or oily material, when present for the purposes for forming an emulsion, will normally form up to 90%, preferably from 10 to 80% by volume of the composition.

Emulsifier

The composition according to the invention can also optionally comprise one or more emulsifiers the choice of which will normally determine whether a water-in-oil or and oil-in-water emulsion is formed.

When a water-in-oil emulsion is required, the chosen emulsifier or emulsifiers should normally have an average HLB value of from 1 to 6. When an oil-in-water emulsion is required, a chosen emulsifier or emulsifiers should have an average HLB value of >6.

Examples of suitable emulsifiers are set below in Table 2 in which the chemical name of the emulsifiers is given together with an example of a trade name as commercially available, and the average HLB value.

Table 2

Chemical Name of Emulsifier	Trade Name	HLB Value
Sorbitan trioleate	Arlacel 85	1.8
Sorbitan tristearate	Span 65	2.1
Glycerol monooleate	Aldo MD	2.7
Glycerol monostearate	Atmul 84S	2.8
Glycerol monolaurate	Aldo MC	3.3
Sorbitan sesquioleate	Arlacel 83	3.7
Sorbitan monooleate	Arlacel 80	4.3
Sorbitan monostearate	Arlacel 60	4.7
Poloxyethylene (2) stearyl ether	Brij 72	4.9
Poloxyethylene sorbitol beeswax derivative	G-1702	5
PEG 200 dilaurate	Emerest 2622	6.3
Sorbitan monopalmitate	Arlacel 40	6.7

	Polyoxyethylene (3.5) nonyl phenol	Emulgen 903	7.8
	PEG 200 monostearate	Tegester PEG 200 MS	8.5
5	Sorbitan monolaurate	Arlacel 200	8.6
	PEG 400 dioleate	Tegester PEG 400-DO	8.8
	Polyoxyethylene (5) monostearate	Ethofat 60-16	9.0
10	Polyoxyethylene (4) sorbitan monostearate	Tween 61	9.6
	Polyoxyethylene (4) lauryl ether	Brij 30	9.7
	Polyoxyethylene (5) sorbitan monooleate	Tween 81	10.0
15	PEG 300 monooleate	Neutronyx 834	10.4
	Polyoxyethylene (20) sorbitan tristearate	Tween 65	10.5
	Polyoxyethylene (20) sorbitan trioleate	Tween 85	11.0
20	Polyoxyethylene (8) monostearate	Myrj 45	11.1
	PEG 400 monooleate	Emerest 2646	11.7
	PEG 400 monostearate	Tegester PEG 400	11.9
25	Polyoxyethylene 10 monooleate	Ethofat 0/20	12.2
	Polyoxyethylene (10) stearyl ether	Brij 76	12.4
	Polyoxyethylene (10) cetyl ether	Brij 56	12.9
30	Polyoxyethylene (9.3) octyl phenol	Triton X-100	13.0
	Polyoxyethylene (4) sorbitan monolaurate	Tween 21	13.3
35	PEG 600 monooleate	Emerest 2660	13.7
	PEG 1000 dilaurate	Kessco	13.9

	Polyoxyethylene sorbitol lanolin derivative	G-1441	14.0
	Polyoxyethylene (12) lauryl ether	Ethospense LA-12	14.4
5	PEG 1500 dioleate	Pegospense 1500	14.6
	Polyoxyethylene (14) laurate	Arosurf HFL-714	14.8
	Polyoxyethylene (20) sorbitan monostearate	Tween	14.9
10	Polyoxyethylene 20 sorbitan monooleate	Tween 80	15.0
	Polyoxyethylene (20) stearyl ether	Brij 78	15.3
	Polyoxyethylene (20) sorbitan monopalmitate	Tween 40	15.6
15	Polyoxyethylene (20) cetyl ether	Brij 58	15.7
	Polyoxyethylene (25) oxypropylene monostearate	G-2162	16.0
20	Polyoxyethylene (20) sorbitol monolaurate	Tween 20	16.7
	Polyoxyethylene (23) lauryl ether	Brij 35	16.9
25	Polyoxyethylene (50) monostearate	Myrj 53	17.9
	PEG 4000 monostearate	Pegospense 4000 MS	18.7

30

The foregoing list of emulsifiers is not intended to be limiting and merely exemplifies selected emulsifiers which are suitable for use in accordance with the invention.

35

It is to be understood that two or more emulsifiers can be employed if desired.

The amount of emulsifier or mixtures thereof, that optionally can be incorporated in the composition of the invention is from 1 to 50%, preferably from 2 to 20% and most preferably from 2 to 10% by weight of the composition.

5

Water

The composition of the invention can also comprise water, usually up to 80%, preferably from 5 to 80% by volume.

10

Silicone Surfactant

The composition of the invention can also optionally comprise a high molecular weight silicone surfactant which can also act as an emulsifier, in place of or in addition to the optional emulsifier(s) already mentioned.

15

The silicone surfactant is a high molecular weight polymer of dimethyl polysiloxane with polyoxyethylene and/or polyoxypropylene side chains having a molecular weight of from 10,000 to 50,000 and having the structure:

20

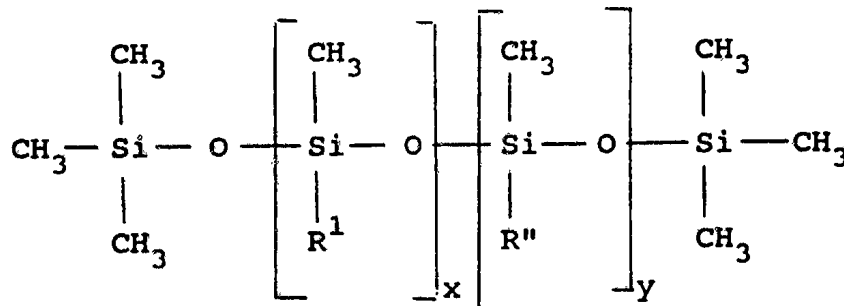

25

30

where the groups R' and R'' are each chosen from -H, C<sub>1-18</sub> alkyl and  
 $-\text{[CH}_2\text{CH}_2\text{O]}_c\text{[CH}_2\text{CHO]}_d\text{H}$   
 $\quad \quad \quad |$   
 $\quad \quad \quad \text{CH}_3$

35

c has a value of from 9 to 115,  
d has a value of from 0 to 50,



x has a value of from 133 to 673,  
y has a value of from 25 to 0.25.

5 Preferably, the dimethyl polysiloxane polymer is one in which:

10 c has a value of from 10 to 114  
d has a value of from 0 to 49  
x has a value of from 388 to 402  
y has a value of from 15 to 0.75

one of groups R' and R" being lauryl, and the other having a molecular weight of from 1000 to 5000.

15 A particularly preferred dimethyl polysiloxane polymer is one in which:

20 c has the value 14  
d has the value 13  
x has the value 249  
y has the value 1.25

25 The dimethyl polysiloxane polymer is conveniently provided as a dispersion in a volatile siloxane, the dispersion comprising, for example, from 1 to 20% by volume of the polymer and from 80 to 99% by volume of the volatile siloxane. Ideally, the dispersion consists of a 10% by volume of the polymer dispersed in the volatile siloxane.

30 Examples of the volatile siloxanes in which the polysiloxane polymer can be dispersed include polydimethyl siloxane (pentamer and/or hexamer).

35 A particularly preferred silicone surfactant is cyclomethicone and dimethicone copolyol, such as DC 3225C Formulation Aid available from DOW CORNING. Another is laurylmethicone copolyol, such as DC Q2-5200, also

available from Dow Corning.

The amount of silicone surfactant, when present in the composition will normally be up to 25%, preferably from 0.5  
5 to 15% by weight of the emulsion.

#### Other Cosmetic Adjuncts

10 Examples of conventional adjuncts which can optionally be employed include preservatives, such as para-hydroxy benzoate esters; antioxidants, such butylated hydroxytoluene; humectants, such as glycerol, sorbitol, 2-pyrrolidone-5-carboxylic acid, dibutylphthalate, gelatin, polyethylene glycol, such as PEG 200-600; buffers, such as  
15 lactic acid together with a base such as triethanolamine or sodium hydroxide; waxes, such as beeswax, ozokerite wax, paraffin wax; plant extracts, such as aloe vera, cornflower, witch hazel, elderflower, cucumber; thickeners; activity enhancers; colourants; and perfumes. Cosmetic  
20 adjuncts can form the balance of the composition.

#### Use of the Composition

25 The composition according to the invention is intended primarily as a skin-care product for topical application to human skin to repair photo-damaged skin and to prevent photo-damage to skin due to exposure to sunlight. In particular, the composition can be used to reduce skin blotchiness and mottling due to hyperpigmentation, to  
30 improve skin texture with reductions in fine wrinkling and otherwise to improve skin colour. In general, the composition, when topically applied to skin, is useful in the prevention and or treatment of actinic damage to all epidermal cells.

Test method - In vitro melanocyte cell culture

Pigment producing cells derived from a mammalian melanoma are grown in culture by standard methods. Preferred cell lines are B16 or S-91 cells, but other lines or primary mouse or human melanocytes can be used.

Melanoma cells are grown in cell culture medium such as RPMI 1640 (GIBCO) supplemented with fetal calf serum and glutamine to approximately 1/3 confluence. The active is dissolved in culture medium, the pH adjusted as required and sterile filtered. The solution is then added to the cells.

The cells are cultured for a further period of 4 days and the amount of melanin produced assayed by measuring the absorbance at 540 nm of the melanin released into the medium.

Cell viability is tested using neutral red (3-amino-7-dimethylamino-2-methyl phenazine hydrochloride) a water soluble vital dye which passes through the intact plasma membrane and becomes concentrated in lysosomes of viable cells. For any culture, the amount of dye taken up is proportional to the number of viable cells and agents that damage cell and lysosomal membranes inhibit dye incorporation.

The cells are incubated in 50  $\mu$ g/ml neutral red solution for 3 hours at 37°C in 5% CO<sub>2</sub> in air. The solution is aspirated, the cells washed once in saline and to them added a solvent (50% H<sub>2</sub>O, 49% ethanol, 1% acetic acid) to solubilise the dye. The amount of neutral red dye is quantified by measuring absorbance at 540 nm.

Results

The above procedure was used to assess the ability of compositions of dioic acids (at a range of concentrations) and retinol (at a range of concentrations) to reduce the amount of melanin produced without affecting cell viability.

These compositions were compared with compositions having retinol alone at a range of concentrations and dioic acids alone at a range of concentrations.

The results for both viability and melanin production were calculated as percentages of the control which contained medium alone. Results are given in Tables 3-7.

Results clearly show that dioic acids and retinol act synergistically to reduce melanin production. There were no effects on cell viability at these concentrations.

Table 3

Trans retinol (mM)	C <sub>9</sub> Dioic Acid (mM)			
	0	0.04	0.1	1.0
0	100	126±3.5	-	0±0.1
0.04	176±1.7	178±2.5	154±8.3	-
0.05	155±9.2	70±12.0	71±9.0	-

Table 4

Trans retinol (mM)	C <sub>12</sub> Dioic Acid (mM)			
	0	0.005	0.05	0.7
0	100	98±0.5	97±0.6	0±0.2
0.05	59±3.0	20±4.1	23±3.5	-

Table 5

Trans retinol (mM)	C <sub>12:1</sub> Dioic Acid and C <sub>14:1</sub> Dioic Acid (mM)			
	0	0.4	0.5	0.7
0	100	113±1.1	109±8.1	1.1±0.1
0.04	-	143±1.9	141±2.6	-
0.05	155±9.1	144±1.7	24±2.2	-

Table 6

Trans retinol (mM)	C <sub>18:2</sub> Dioic Acid (mM)			
	0	0.2	0.25	0.7
0	100	102±2.6	100±0.6	0±0.4
0.04	-	126±1.9	114±2.0	-
0.05	156±9.1	101±2.0	0±0.5	-

Table 7

Trans retinol (mM)	C <sub>18:1</sub> Dioic Acid (mM)			
	0	0.15	0.2	0.3
0	100	107±2.3	100±5.8	0.5±0.2
0.04	-	136±0.8	137±2.1	-
0.05	155±9.1	136±4.4	0±0.4	-

EXAMPLES

The invention is further illustrated by the following examples; in each formulation, the titanium dioxide employed was ultrafine titanium dioxide having a mean particle size of from 15 to 25nm.

Example 1

This example illustrates a lotion according to the invention.

5

	<u>Ingredient</u>	<u>% w/w</u>
	retinyl propionate	1
	azelaic acid	20
10	silicone surfactant	10
	volatile siloxane	14
	mineral oil	1.5
	titanium dioxide (water-dispersible)	2.5
	titanium dioxide (oil-dispersible)	2.5
15	2-hydroxyoctanoic acid	1
	2-hydroxypropanoic acid	5
	butylene glycol	10
	sodium chloride	2
	l-proline	0.1
20	neutralising agent	qs
	preservative	qs
	perfume	qs
	water	qs

Example 2

This example illustrates a fluid cream according to the invention.

5

	<u>Ingredient</u>	<u>% w/w</u>
	retinyl acetate	0.3
	C <sub>18</sub> mono-unsaturated dioic acid	20
10	volatile siloxane (DC 345)	8.2
	silicone surfactant (DC 3225C)	12
	petroleum jelly	0.5
	mineral oil	1.5
	Parsol MCX (octyl methoxycinnamate)	3
15	titanium dioxide (oil-dispersible)	2
	titanium dioxide (water-dispersible)	2
	sodium chloride	2
	butylene glycol	10
	l-proline	0.1
20	2-hydroxyoctanoic acid	1
	2-hydroxypropanoic acid	5
	neutralising agent	qs
	preservative	qs
	perfume	qs
25	water	qs

Example 3

This example illustrates a cream according to the invention.

5

	<u>Ingredient</u>	<u>% w/w</u>
	retinyl palmitate	1
	azelaic acid	15
10	volatile siloxane (DC 345 Fluid)	8.2
	silicone surfactant (DC 3225C)	12
	mineral oil	1.5
	petroleum jelly	0.5
	Parsol MCX (octyl methoxycinnamate)	1.5
15	titanium dioxide (oil-dispersible)	1.0
	titanium dioxide (water-dispersible)	1
	2-hydroxyoctanoic acid	1
	2-hydroxypropanoic acid	5
	sodium chloride	2
20	butylene glycol	10
	l-proline	0.1
	neutralising agent (aqueous phase to 4.5)	qs
	preservative	qs
	perfume	qs
25	water	to 100



Example 4

This example illustrates a lotion according to the invention.

5

	<u>Ingredient</u>	<u>% w/w</u>
	retinyl linoleate	0.5
	retinyl palmitate	0.5
10	C <sub>18</sub> di-unsaturated dioic acid	20
	silicone surfactant (DC 3225C)	10
	volatile siloxane (DC 345)	14
	mineral oil	1.5
	Parsol MCX	3
15	titanium dioxide (oil-dispersible)	2
	titanium dioxide (water-dispersible)	2
	butylene glycol	10
	sodium chloride	2
	l-proline	0.1
20	2-hydroxyoctanoic acid	1
	2-hydroxypropanoic acid	5
	neutralising agent	qs
	perfume	qs
	preservative	qs
25	water	qs

Example 5

This example illustrates a sunscreen cream in accordance with the invention.

5

	<u>Ingredient</u>	<u>% w/w</u>
	retinyl oleate	2
	retinyl acetate	1
10	C <sub>12</sub> mono-unsaturated dioic acid	10
	C <sub>14</sub> mono-unsaturated dioic acid	10
	Polyoxyethylene (2) stearyl alcohol	3
	Polyoxyethylene (21) stearyl alcohol	2
	cetyl alcohol	1.5
15	soft white paraffin	1.5
	silicone fluid 200	5
	liquid paraffin	8
	glycerin	2
	preservatives	0.5
20	titanium dioxide (water-dispersible)	2.5
	titanium dioxide (oil-dispersible)	2.5
	water	to 100

Example 6

This example also illustrates a sunscreen cream in accordance with the invention.

5

	<u>Ingredients</u>	<u>% w/w</u>
	retinyl acetate	0.2
	retinyl laurate	2
10	C <sub>14</sub> di-unsaturated dioic acid	20
	cetyl dimethicone copolyol )	
	cetyl dimethicone ) *	5
	polyglyceryl-3-oleate )	
	hexyl laurate )	
15	isopropyl myristate	13.5
	beeswax	3
	silicone fluid 200	5
	preservatives	0.5
	titanium dioxide (water-dispersible)	2.5
20	titanium dioxide (oil-dispersible)	2.5
	water	to 100

\* available is ABIL W508 ex Goldschmidt

Example 7

This example illustrates a lotion according to the invention.

	<u>Ingredient</u>	<u>% w/w</u>
	retinyl octanoate	2
	C <sub>14</sub> mono-unsaturated dioic acid	20
10	silicone surfactant	10
	volatile siloxane	14
	mineral oil	1.5
	ultrafine titanium dioxide (water-dispersible)	5
15	2-hydroxyoctanoic acid	1
	2-hydroxypropanoic acid	5
	butylene glycol	10
	sodium chloride	2
	amino acid	0.1
20	neutralising agent	qs
	preservative	qs
	perfume	qs
	water	qs

Example 8

This example illustrates a lotion according to the invention.

5	<u>Ingredient</u>	<u>% w/w</u>
	retinyl palmitate	2
	C <sub>22</sub> mono-unsaturated dioic acid	20
10	silicone surfactant	10
	volatile siloxane	14
	mineral oil	1.5
	ultrafine titanium dioxide (oil-dispersible)	5
15	2-hydroxyoctanoic acid	1
	2-hydroxypropanoic acid	5
	butylene glycol	10
	sodium chloride	2
	amino acid	0.1
20	neutralising agent	qs
	preservative	qs
	perfume	qs
	water	qs

Example 9

This example illustrates a lotion according to the invention.

5

<u>Ingredient</u>	<u>% w/w</u>
retinyl octanoate	1
retinyl linoleate	1
10 C <sub>8</sub> mono-unsaturated dioic acid	15
silicone surfactant	10
volatile siloxane	14
mineral oil	1.5
ultrafine titanium dioxide (water-dispersible)	2.5
15 ultrafine titanium dioxide (oil-dispersible)	2.50
2-hydroxyoctanoic acid	1
2-hydroxypropanoic acid	5
20 butylene glycol	10
sodium chloride	2
amino acid	0.1
neutralising agent	qs
preservative	qs
25 perfume	qs
water	qs

CLAIMS

1. A composition suitable for topical application to human skin in order to promote repair of photo-damaged skin and/or to reduce or prevent the damaging effects of ultra-violet light on skin, and/or to lighten the skin, which composition comprises:

i) an effective amount of from 0.01 to 10% by weight of retinol or a derivative thereof having the structure

(1)

:

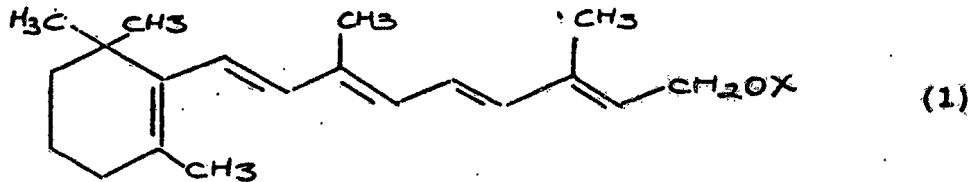

where X represents H or  $-\text{COR}^1$  where  $\text{R}^1$  represents a group chosen from branched or unbranched, alkyl or alkenyl groups having an average of from 1 to 20 carbon atoms;

ii) an effective amount of from 0.1 to 30% by weight of a dioic acid having the general structure (2)



where a is an integer of from 6 to 20 and b is an integer of from 8 to 40; and

iii) a cosmetically acceptable vehicle

2. A composition according to claim 1 wherein the amount of retinol or a derivative thereof having the structure (1) is from 0.05 to 5% by weight of the composition.



3. A composition according to any preceding claim wherein the amount of retinol or a derivative thereof having the structure (1) is from 0.05 to 1% by weight of the composition.

4. A composition according to any preceding claim wherein the amount of dioic acid is from 1 to 25% by weight of the composition.

5. A composition according to any preceding claim wherein the amount of dioic acid is from 5 to 20% by weight of the composition.

6. A composition according to any preceding claim wherein the dioic acid is selected from C<sub>9</sub> to C<sub>18</sub> saturated, mono- and di-unsaturated dioic acids and mixtures thereof.

7. A composition according to any preceding claim wherein the composition comprises trans-retinol.

8. Use of a composition according to any preceding claim in the repair of photo-damaged skin and/or in the prevention of damage to the skin due to exposure to ultraviolet light.

DATED 11 April 1997

SIGNED for and on behalf of UNILEVER PLC  
by Unilever Australia Limited

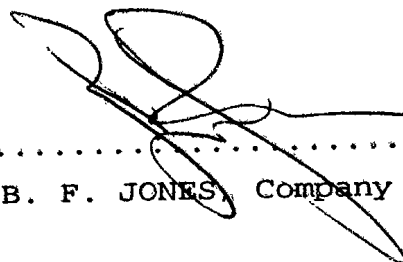

.....  
B. F. JONES, Company Secretary





INTERNATIONAL SEARCH REPORT

International Application No  
PCT/EP 93/02341

A. CLASSIFICATION OF SUBJECT MATTER  
IPC 5 A61K7/48 A61K7/42

According to International Patent Classification (IPC) or to both national classification and IPC

B. FIELDS SEARCHED

Minimum documentation searched (classification system followed by classification symbols)  
IPC 5 A61K

Documentation searched other than minimum documentation to the extent that such documents are included in the fields searched

Electronic data base consulted during the international search (name of data base and, where practical, search terms used)

C. DOCUMENTS CONSIDERED TO BE RELEVANT

Category *	Citation of document, with indication, where appropriate, of the relevant passages	Relevant to claim No.
Y	US,A,5 002 760 (P. K. KATZEV) 26 March 1991 see the whole document ---	1-9
Y	EP,A,0 297 436 (C. R. THORNFELDT) 4 January 1989 see the whole document ---	1-9
A	EP,A,0 229 654 (C. R. THORNFELDT) 22 July 1987 see the whole document ---	1-9
A	PATENT ABSTRACTS OF JAPAN vol. 16, no. 156 (C-930)16 April 1992 & JP,A,04 009 325 (SUNSTAR INC) 14 January 1992 see abstract -----	1-9

Further documents are listed in the continuation of box C.

Patent family members are listed in annex.

\* Special categories of cited documents :

- 'A' document defining the general state of the art which is not considered to be of particular relevance
- 'E' earlier document but published on or after the international filing date
- 'L' document which may throw doubts on priority claim(s) or which is cited to establish the publication date of another citation or other special reason (as specified)
- 'O' document referring to an oral disclosure, use, exhibition or other means
- 'P' document published prior to the international filing date but later than the priority date claimed

- 'T' later document published after the international filing date or priority date and not in conflict with the application but cited to understand the principle or theory underlying the invention
- 'X' document of particular relevance; the claimed invention cannot be considered novel or cannot be considered to involve an inventive step when the document is taken alone
- 'Y' document of particular relevance; the claimed invention cannot be considered to involve an inventive step when the document is combined with one or more other such documents, such combination being obvious to a person skilled in the art.
- '&' document member of the same patent family

Date of the actual completion of the international search

20 December 1993

Date of mailing of the international search report

24. 12. 93

Name and mailing address of the ISA

European Patent Office, P.B. 5818 Patentlaan 2  
NL - 2280 HV Rijswijk  
Tel. (+ 31-70) 340-2040, Fax 31 651 epo nl,  
Fax (+ 31-70) 340-3016

Authorized officer

Sierra Gonzalez, M

## INTERNATIONAL SEARCH REPORT

International application No.

PCT/EP 93/02341

**Box I Observations where certain claims were found unsearchable (Continuation of item 1 of first sheet)**

This international search report has not been established in respect of certain claims under Article 17(2)(a) for the following reasons:

1.  Claims Nos.:  
because they relate to subject matter not required to be searched by this Authority, namely:  
Remark: Although claim 9 is directed to a method of treatment of the human body the search has been carried out and based on the alleged effects of the composition.
2.  Claims Nos.:  
because they relate to parts of the international application that do not comply with the prescribed requirements to such an extent that no meaningful international search can be carried out, specifically:
3.  Claims Nos.:  
because they are dependent claims and are not drafted in accordance with the second and third sentences of Rule 6.4(a).

**Box II Observations where unity of invention is lacking (Continuation of item 2 of first sheet)**

This International Searching Authority found multiple inventions in this international application, as follows:

1.  As all required additional search fees were timely paid by the applicant, this international search report covers all searchable claims.
2.  As all searchable claims could be searched without effort justifying an additional fee, this Authority did not invite payment of any additional fee.
3.  As only some of the required additional search fees were timely paid by the applicant, this international search report covers only those claims for which fees were paid, specifically claims Nos.:
4.  No required additional search fees were timely paid by the applicant. Consequently, this international search report is restricted to the invention first mentioned in the claims; it is covered by claims Nos.:

Remark on Protest

- The additional search fees were accompanied by the applicant's protest.
- No protest accompanied the payment of additional search fees.

# INTERNATIONAL SEARCH REPORT

Information on patent family members

International Application No

PCT/EP 93/02341

Patent document cited in search report	Publication date	Patent family member(s)	Publication date
US-A-5002760	26-03-91	NONE	
EP-A-0297436	04-01-89	US-A- 4885282 JP-A- 1029308	05-12-89 31-01-89
EP-A-0229654	22-07-87	US-A- 4713394 JP-A- 62215522	15-12-87 22-09-87