



US00RE47551E

(19) **United States**
(12) **Reissued Patent**
Jackson

(10) **Patent Number:** **US RE47,551 E**
(45) **Date of Reissued Patent:** **Aug. 6, 2019**

(54) **POLYAXIAL BONE SCREW WITH SPHERICAL CAPTURE, COMPRESSION INSERT AND ALIGNMENT AND RETENTION STRUCTURES**

(58) **Field of Classification Search**
CPC A61B 17/7037; A61B 17/7038; A61B 17/7032
USPC 606/246, 250-253, 264-272, 300-309, 606/319
See application file for complete search history.

(71) Applicant: **Roger P. Jackson**, Prairie Village, KS (US)

(56) **References Cited**

(72) Inventor: **Roger P. Jackson**, Prairie Village, KS (US)

U.S. PATENT DOCUMENTS

(21) Appl. No.: **15/902,433**

791,548 A 6/1905 Fischer
1,300,275 A 4/1919 Johnson
(Continued)

(22) Filed: **Feb. 22, 2018**

FOREIGN PATENT DOCUMENTS

Related U.S. Patent Documents

Reissue of:

DE 3630863 3/1988
DE 373809 5/1989
(Continued)

(64) Patent No.: **9,414,863**
Issued: **Aug. 16, 2016**
Appl. No.: **13/507,822**
Filed: **Jul. 31, 2012**

OTHER PUBLICATIONS

U.S. Applications:

Brochure of Tyco/Healthcare/Surgical Dynamics on Spiral Radius 90D, Publication Date: Sep. 2001, pp. 1-8.
(Continued)

(63) Continuation of application No. 12/072,354, filed on Feb. 26, 2008, now Pat. No. 10,076,361, which is a continuation-in-part of application No. 11/126,965, filed on May 10, 2005, now Pat. No. 7,476,239, and a continuation-in-part of application No. 12/008,067, filed on Jan. 8, 2008, now Pat. No. 7,901,437, and a continuation-in-part of application No. 12/924,260, filed on Sep. 23, 2010, now Pat. No. 8,403,962, which is a continuation-in-part of application No. (Continued)

Primary Examiner — Beverly M Flanagan
(74) *Attorney, Agent, or Firm* — Polsinelli PC

(57) **ABSTRACT**

A polyaxial bone screw assembly includes a receiver, a shank, an articulation structure for retaining the shank in the receiver and a compression insert for engagement with a longitudinal connecting member such as a rod. The articulation structure includes substantially spherical convex and concave surfaces that slidably engage both shank and receiver surfaces to provide compound articulation between the receiver and the shank. The receiver includes inwardly directed spring tabs engaging the insert and prohibiting rotation of the insert within the receiver.

(51) **Int. Cl.**
A61B 17/70 (2006.01)

(52) **U.S. Cl.**
CPC **A61B 17/7037** (2013.01); **A61B 17/7032** (2013.01)

46 Claims, 9 Drawing Sheets

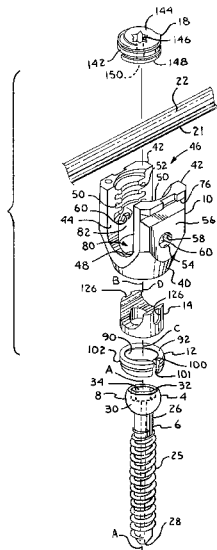

Related U.S. Application Data

11/385,957, filed on Mar. 21, 2006, now abandoned, which is a continuation-in-part of application No. 11/178,854, filed on Jul. 11, 2005, now Pat. No. 7,789,896.

- (60) Provisional application No. 60/905,472, filed on Mar. 7, 2007, provisional application No. 60/897,723, filed on Jan. 26, 2007, provisional application No. 60/655,239, filed on Feb. 22, 2005.

(56) References Cited

U.S. PATENT DOCUMENTS

1,330,673 A	2/1920	Anderson	5,022,791 A	6/1991	Isler
2,083,092 A	1/1936	Richer	5,026,373 A	6/1991	Ray et al.
2,201,087 A	5/1940	Hallowell	5,034,011 A	7/1991	Howland
2,239,352 A	4/1941	Cherry	5,056,492 A	10/1991	Banse
2,243,717 A	5/1941	Moreira	5,067,955 A	11/1991	Cotrel
2,295,314 A	9/1942	Whitney	5,073,074 A	12/1991	Corrigan et al.
2,346,346 A	4/1944	Anderson	5,092,635 A	3/1992	DeLange et al.
2,362,999 A	11/1944	Elmer	5,102,412 A	4/1992	Rogozinski
2,537,029 A	8/1946	Cambern	5,129,388 A	7/1992	Vignaud et al.
2,445,978 A	7/1948	Stellin	5,129,899 A	7/1992	Small et al.
2,531,892 A	11/1950	Reese	5,147,360 A	9/1992	Dubousset
2,531,896 A	11/1950	Reese	5,147,363 A	9/1992	Harle
2,532,815 A	12/1950	Kindsvatner	5,154,719 A	10/1992	Cotrel
2,553,337 A	5/1951	Shafer	5,176,483 A	1/1993	Baumann et al.
2,778,265 A	1/1957	Brown	5,176,678 A	1/1993	Tsou
2,813,450 A	11/1957	Dzus	5,176,680 A	1/1993	Vignaud et al.
2,969,250 A	1/1959	Kull	5,180,393 A	1/1993	Commarmond
2,877,681 A	3/1959	Brown	5,207,678 A	5/1993	Harms et al.
2,927,332 A	3/1960	Moore	5,217,497 A	6/1993	Mehdian
3,013,244 A	12/1961	Rudy	5,257,993 A	11/1993	Asher et al.
3,143,029 A	8/1964	Brown	5,261,907 A	11/1993	Vignaud et al.
D200,217 S	2/1965	Curtiss	5,261,912 A	11/1993	Frigg
3,236,275 A	2/1966	Smith	5,275,601 A	1/1994	Gogolewski et al.
3,370,341 A	2/1968	Allsop	5,282,707 A	2/1994	Palm
3,498,174 A	3/1970	Schuster et al.	5,282,863 A	2/1994	Burton
3,584,667 A	6/1971	Reiland	5,306,275 A	4/1994	Bryan
3,604,487 A	9/1971	Gilbert	5,312,404 A	5/1994	Asher et al.
3,640,416 A	2/1972	Temple	5,321,901 A	6/1994	Kelly
3,812,757 A	5/1974	Reiland	5,334,203 A	8/1994	Wagner
3,963,322 A	6/1976	Gryctko	5,346,493 A	9/1994	Stahurski et al.
4,033,139 A	7/1977	Frederick	5,354,299 A	10/1994	Coleman
4,041,939 A	8/1977	Hall	5,358,289 A	10/1994	Banker et al.
4,103,422 A	8/1978	Weiss	5,360,431 A	11/1994	Puno et al.
4,269,246 A	5/1981	Larson et al.	5,364,400 A	11/1994	Rego, Jr. et al.
4,369,769 A	1/1983	Edwards	5,375,823 A	12/1994	Navas
4,373,754 A	2/1983	Bollfrass et al.	5,382,248 A	1/1995	Jacobson et al.
4,448,191 A	5/1984	Rodnyansky et al.	5,385,583 A	1/1995	Cotrel
4,484,570 A	11/1984	Sutter et al.	5,387,212 A	2/1995	Yuan et al.
4,492,500 A	1/1985	Ewing	5,395,371 A	3/1995	Miller et al.
4,506,917 A	3/1985	Hansen Arne	5,415,661 A	5/1995	Holmes
4,577,448 A	3/1986	Howorth	5,423,816 A	6/1995	Lin
4,600,224 A	7/1986	Blose	5,427,418 A	6/1995	Watts
4,641,636 A	2/1987	Cotrel	5,429,639 A	7/1995	Judet
4,653,486 A	3/1987	Coker	5,443,467 A	8/1995	Biedermann et al.
4,703,954 A	11/1987	Ortloff et al.	5,466,237 A	11/1995	Byrd, III et al.
4,707,001 A	11/1987	Johnson	5,468,241 A	11/1995	Metz-Stavenhagen et al.
4,743,260 A	5/1988	Burton	5,474,551 A	12/1995	Finn et al.
4,748,260 A	5/1988	Marlett	5,474,555 A	12/1995	Puno et al.
4,759,672 A	7/1988	Nilsen et al.	5,476,462 A	12/1995	Allard et al.
4,763,644 A	8/1988	Webb	5,476,464 A	12/1995	Metz-Stavenhagen et al.
4,764,068 A	8/1988	Crispell	5,480,401 A	1/1996	Navas
4,790,297 A	12/1988	Luque	5,487,742 A	1/1996	Cotrel
4,805,602 A	2/1989	Puno et al.	5,489,307 A	2/1996	Kuslich et al.
4,815,453 A	3/1989	Cotrel	5,490,750 A	2/1996	Gundy
4,836,196 A	6/1989	Park et al.	5,496,321 A	3/1996	Puno et al.
4,838,264 A	6/1989	Bremer et al.	5,499,892 A	3/1996	Reed
4,850,775 A	7/1989	Lee	5,507,745 A	4/1996	Logroscino et al.
4,887,596 A	12/1989	Sherman	5,507,747 A	4/1996	Yuan et al.
4,946,458 A	8/1990	Harms et al.	5,540,688 A	7/1996	Navas
4,950,269 A	8/1990	Gaines, Jr.	5,545,165 A	8/1996	Biedermann et al.
5,005,562 A	4/1991	Cotrel	5,554,157 A	9/1996	Errico et al.
5,019,080 A	5/1991	Hemer	5,562,663 A	10/1996	Wisnewski et al.
			5,569,247 A	10/1996	Morrison
			5,569,251 A	10/1996	Baker et al.
			5,584,834 A	12/1996	Errico et al.
			5,586,984 A	12/1996	Errico et al.
			5,591,166 A	1/1997	Bernhardt et al.
			5,591,235 A	1/1997	Kuslich
			5,601,553 A	2/1997	Trebing et al.
			5,607,304 A	3/1997	Bailey et al.
			5,607,425 A	3/1997	Rogozinski
			5,607,426 A	3/1997	Ralph et al.
			5,607,428 A	3/1997	Lin
			5,611,800 A	3/1997	Davis et al.
			5,624,442 A	4/1997	Mellinger et al.
			5,628,740 A	5/1997	Mullane
			5,630,817 A	5/1997	Rokegem
			5,641,256 A	6/1997	Gundy
			5,643,260 A	7/1997	Doherty

(56)

References Cited

U.S. PATENT DOCUMENTS

5,643,261	A	7/1997	Schafer et al.	6,186,718	B1	2/2001	Fogard
5,647,873	A	7/1997	Errico et al.	6,187,005	B1	2/2001	Brace et al.
5,653,710	A	8/1997	Harle	6,193,719	B1	2/2001	Gournay et al.
5,662,652	A	9/1997	Schafer et al.	6,214,012	B1	4/2001	Karpman et al.
5,662,653	A	9/1997	Songer et al.	RE37,161	E	5/2001	Michelson et al.
5,669,909	A	9/1997	Zdeblick et al.	6,224,596	B1	5/2001	Jackson
5,669,911	A	9/1997	Errico et al.	6,224,598	B1	5/2001	Jackson
5,672,175	A	9/1997	Martin	6,235,034	B1	5/2001	Bray
5,672,176	A	9/1997	Biedermann et al.	6,241,730	B1	6/2001	Alby
5,681,319	A	10/1997	Biedermann et al.	6,248,105	B1	6/2001	Schlapfer et al.
5,683,390	A	11/1997	Metz-Stavenhagen et al.	6,254,146	B1	7/2001	Church
5,690,630	A	11/1997	Errico et al.	6,254,602	B1	7/2001	Justis
5,697,929	A	12/1997	Mellinger	6,261,039	B1	7/2001	Reed
5,711,709	A	1/1998	McCoy	6,267,764	B1	7/2001	Elberg
5,713,705	A	2/1998	Grunbichler	6,267,765	B1	7/2001	Taylor et al.
5,713,898	A	2/1998	Stucker et al.	6,273,888	B1	8/2001	Justis
5,716,356	A	2/1998	Biedermann et al.	6,280,442	B1	8/2001	Barker et al.
5,723,013	A	3/1998	Jeanson et al.	6,280,445	B1	8/2001	Morrison et al.
5,725,527	A	3/1998	Biedermann et al.	6,287,308	B1	9/2001	Betz et al.
5,725,528	A	3/1998	Errico et al.	6,287,311	B1	9/2001	Sherman et al.
5,728,098	A	3/1998	Sherman et al.	6,296,642	B1	10/2001	Morrison et al.
5,733,286	A	3/1998	Errico et al.	6,296,643	B1	10/2001	Hopf et al.
5,738,685	A	4/1998	Halm et al.	6,299,613	B1	10/2001	Ogilvie et al.
5,741,254	A	4/1998	Henry et al.	6,302,888	B1	10/2001	Mellinger et al.
5,752,957	A	5/1998	Ralph et al.	6,309,391	B1	10/2001	Crandall et al.
5,782,833	A	7/1998	Haider	6,315,564	B1	11/2001	Levisman
5,797,911	A	8/1998	Sherman et al.	6,322,108	B1	11/2001	Riesselmann et al.
5,800,435	A	9/1998	Errico et al.	6,331,179	B1	12/2001	Freid et al.
5,800,547	A	9/1998	Schafer et al.	6,349,794	B2	2/2002	Spencer
5,817,094	A	10/1998	Errico et al.	6,355,040	B1	3/2002	Richelsoph et al.
5,863,293	A	1/1999	Richelsoph	6,361,535	B2	3/2002	Jackson
5,873,878	A	2/1999	Harms et al.	RE37,665	E	4/2002	Ralph et al.
D407,302	S	3/1999	Lawson	6,368,321	B1	4/2002	Jackson
5,876,402	A	3/1999	Errico et al.	6,371,957	B1	4/2002	Amrein et al.
5,879,350	A	3/1999	Sherman et al.	6,375,657	B1	4/2002	Doubler et al.
5,879,351	A	3/1999	Viart	6,402,752	B2	6/2002	Schaffler-Wachter et al.
5,882,350	A	3/1999	Ralph et al.	6,402,757	B1	6/2002	Moore et al.
5,885,286	A	3/1999	Sherman et al.	6,432,109	B1	8/2002	Letendart et al.
5,891,145	A	4/1999	Morrison et al.	6,440,135	B2	8/2002	Orgay et al.
5,902,303	A	5/1999	Eckhof et al.	6,440,137	B1	8/2002	Horvath et al.
RE36,221	E	6/1999	Breard et al.	6,443,953	B1	9/2002	Perra et al.
5,910,142	A	6/1999	Tatar	6,451,021	B1	9/2002	Ralph et al.
5,938,663	A	8/1999	Petreto	6,454,772	B1	9/2002	Jackson
5,944,465	A	8/1999	Janitzki	6,471,703	B1	10/2002	Ashman
5,954,725	A	9/1999	Sherman et al.	6,471,705	B1	10/2002	Biedermann et al.
5,961,517	A	10/1999	Biedermann et al.	6,485,491	B1	11/2002	Farris et al.
5,964,760	A	10/1999	Richelsoph	6,485,492	B1	11/2002	Halm et al.
6,001,098	A	12/1999	Metz-Stavenhagen et al.	6,485,494	B1	11/2002	Haider
6,004,349	A	12/1999	Jackson	6,488,681	B2	12/2002	Martin et al.
6,010,503	A	1/2000	Richelsoph et al.	6,508,818	B2	1/2003	Steiner et al.
6,019,759	A	2/2000	Rogozinski	6,520,962	B1	2/2003	Taylor et al.
6,022,350	A	2/2000	Ganem	6,520,963	B1	2/2003	McKinley
6,053,078	A	4/2000	Parker	6,527,804	B1	3/2003	Gauchet et al.
6,053,917	A	4/2000	Sherman et al.	6,530,929	B1	3/2003	Jusis et al.
6,059,786	A	5/2000	Jackson	6,533,786	B1	3/2003	Needham et al.
6,063,090	A	5/2000	Schlapfer	6,540,749	B2	4/2003	Schafer et al.
6,074,391	A	6/2000	Metz-Stavenhagen et al.	6,547,790	B2	4/2003	Harkey, III et al.
6,077,262	A	6/2000	Schlapfer et al.	6,551,320	B2	4/2003	Liebermann
6,086,588	A	7/2000	Ameil et al.	6,551,323	B2	4/2003	Doubler et al.
6,090,110	A	7/2000	Metz-Stavenhagen	6,554,831	B1	4/2003	Rivard et al.
6,090,111	A	7/2000	Nichols	6,554,832	B2	4/2003	Shluzas
6,099,528	A	8/2000	Saurat	6,554,834	B1	4/2003	Crozet et al.
6,102,913	A	8/2000	Jackson	6,558,387	B2	5/2003	Errico et al.
6,110,172	A	8/2000	Jackson	6,562,040	B1	5/2003	Wagner
6,113,601	A	9/2000	Tatar	6,565,565	B1	5/2003	Yuan et al.
6,117,137	A	9/2000	Halm et al.	6,565,567	B1	5/2003	Haider
6,132,431	A	10/2000	Nilsson et al.	6,582,436	B2	6/2003	Schlapfer et al.
6,132,432	A	10/2000	Richelsoph	6,582,466	B1	6/2003	Gauchet
6,132,434	A	10/2000	Sherman et al.	6,585,740	B2	7/2003	Schlapfer et al.
6,136,002	A	10/2000	Shih et al.	6,595,992	B1	7/2003	Wagner et al.
6,139,550	A	10/2000	Michelson	6,595,993	B2	7/2003	Donno et al.
6,143,032	A	11/2000	Schafer et al.	6,602,255	B1	8/2003	Campbell
6,146,383	A	11/2000	Studer et al.	6,610,063	B2	8/2003	Kumar et al.
6,149,533	A	11/2000	Finn	6,613,050	B1	9/2003	Wagner et al.
6,183,472	B1	2/2001	Lutz	6,623,485	B2	9/2003	Doubler et al.
				6,626,907	B2	9/2003	Campbell et al.
				6,626,908	B2	9/2003	Cooper et al.
				6,635,059	B2	10/2003	Randall et al.
				6,648,885	B1	11/2003	Friesem

(56)

References Cited

U.S. PATENT DOCUMENTS

6,648,887	B2	11/2003	Ashman	7,022,122	B2	4/2006	Amrein et al.	
6,652,526	B1	11/2003	Arafiles	7,029,475	B2	4/2006	Panjabi	
6,652,765	B1	11/2003	Beaty	RE39,089	E	5/2006	Ralph et al.	
6,656,179	B1	12/2003	Schaefer et al.	7,066,062	B2	6/2006	Flesher	
6,656,181	B2	12/2003	Dixon et al.	7,066,937	B2	6/2006	Shluzas	
6,660,004	B2	12/2003	Barker et al.	7,081,116	B1	7/2006	Carly	
6,663,632	B1	12/2003	Frigg	7,083,621	B2	8/2006	Shaolian et al.	
6,663,635	B2	12/2003	Frigg et al.	7,087,057	B2	8/2006	Konieczynski et al.	
6,673,073	B1	1/2004	Schafer	7,090,674	B2	8/2006	Doubler et al.	
6,676,661	B1	1/2004	Martin Benlloch et al.	7,121,755	B2	10/2006	Schlapfer et al.	
6,679,833	B2	1/2004	Smith et al.	7,125,410	B2	10/2006	Freudiger	
6,682,529	B2	1/2004	Stahurski	7,125,426	B2	10/2006	Moumene et al.	
6,682,530	B2	1/2004	Dixon et al.	7,128,743	B2	10/2006	Metz-Stavenhagen	
6,689,133	B2	2/2004	Morrison et al.	7,137,985	B2	11/2006	Jahng	
6,689,134	B2	2/2004	Ralph et al.	7,141,051	B2	11/2006	Janowski et al.	
6,692,500	B2	2/2004	Reed	7,144,396	B2	12/2006	Shluzas	
6,695,843	B2	2/2004	Biedermann et al.	7,163,538	B2	1/2007	Altarac et al.	
6,695,851	B2	2/2004	Zdeblick et al.	7,163,539	B2	1/2007	Abdelgany et al.	
6,699,249	B2	3/2004	Schlapfer et al.	7,166,108	B2	1/2007	Mazda et al.	
6,706,045	B2	3/2004	Lin et al.	7,186,255	B2	3/2007	Baynham et al.	
6,712,818	B1	3/2004	Michelson	7,207,992	B2	4/2007	Ritland	
6,716,213	B2	4/2004	Shitoto	7,211,086	B2	5/2007	Biedermann et al.	
6,716,214	B1	4/2004	Jackson	7,211,087	B2	5/2007	Young	
6,716,247	B2	4/2004	Michelson	7,214,227	B2	5/2007	Colleran et al.	
6,723,100	B2	4/2004	Biedermann et al.	7,223,268	B2	5/2007	Biedermann	
6,726,689	B2	4/2004	Jackson	7,229,441	B2	6/2007	Trieu et al.	
6,730,093	B2	5/2004	Saint Martin	7,264,621	B2	9/2007	Coates et al.	
6,730,127	B2	5/2004	Michelson	7,270,665	B2	9/2007	Morrison et al.	
6,733,502	B2	5/2004	Altarac et al.	7,291,151	B2	11/2007	Alvarez	
6,736,816	B2	5/2004	Ritland	7,291,153	B2	11/2007	Glascott	
6,736,820	B2	5/2004	Biedermann et al.	7,294,128	B2	11/2007	Alleyne et al.	
6,740,086	B2	5/2004	Richelsoph	7,294,129	B2	11/2007	Hawkins et al.	
6,746,449	B2	6/2004	Jones et al.	7,306,603	B2	12/2007	Boehm, Jr. et al.	
6,755,829	B1	6/2004	Bono et al.	7,306,604	B2	12/2007	Carli	
6,755,835	B2	6/2004	Schultheiss et al.	7,306,606	B2	12/2007	Sasing	
6,755,836	B1	6/2004	Lewis	7,314,467	B2	1/2008	Howland	
6,761,723	B2	7/2004	Buttermann et al.	7,316,684	B1	1/2008	Baccelli et al.	
6,767,351	B2	7/2004	Orbay et al.	7,322,979	B2	1/2008	Crandall et al.	
6,770,075	B2	8/2004	Howland	7,335,201	B2	2/2008	Doubler et al.	
6,780,186	B2	8/2004	Errico et al.	7,335,202	B2	2/2008	Matthis et al.	
6,783,527	B2	8/2004	Drewry et al.	7,338,490	B2	3/2008	Ogilvie et al.	
6,790,209	B2	9/2004	Beale et al.	7,338,491	B2	3/2008	Baker et al.	
6,802,844	B2	10/2004	Ferree	7,445,627	B2*	11/2008	Hawkes et al.	A61B 17/7032 606/266
6,827,719	B2	12/2004	Ralph et al.	7,476,228	B2	1/2009	Abdou	
6,830,571	B2	12/2004	Lenke et al.	7,479,156	B2	1/2009	Lourdel et al.	
6,835,196	B2	12/2004	Biedermann et al.	7,491,218	B2	2/2009	Landry et al.	
6,837,889	B2	1/2005	Shluzas	7,491,221	B2	2/2009	David	
6,840,940	B2	1/2005	Ralph et al.	7,503,918	B2	3/2009	Baccelli et al.	
6,843,791	B2	1/2005	Serhan	7,503,924	B2	3/2009	Lee et al.	
6,858,031	B2	2/2005	Morrison et al.	7,524,323	B2	4/2009	Malandain	
6,869,432	B2	3/2005	Schlapfer et al.	7,527,640	B2	5/2009	Ziolo et al.	
6,869,433	B2*	3/2005	Glascott 606/308	7,530,992	B2	5/2009	Biedermann et al.	
6,872,208	B1	3/2005	McBride et al.	7,559,943	B2	7/2009	Mjuwid	
6,896,676	B2	5/2005	Zubok et al.	7,563,264	B2	7/2009	Landry et al.	
6,896,677	B1	5/2005	Lin	7,563,275	B2	7/2009	Falahee et al.	
6,932,817	B2	8/2005	Baynham et al.	7,569,061	B2	8/2009	Colleran	
6,932,820	B2	8/2005	Osman	7,569,068	B2	8/2009	Ramare	
6,945,972	B2	9/2005	Frigg et al.	7,572,280	B2	8/2009	Dickinson et al.	
6,953,462	B2	10/2005	Liebermann	7,575,587	B2	8/2009	Rezach et al.	
6,955,677	B2	10/2005	Dahners	7,588,575	B2	9/2009	Colleran et al.	
6,958,065	B2	10/2005	Ueyama et al.	7,588,588	B2	9/2009	Spitler et al.	
6,964,664	B2	11/2005	Freid et al.	7,588,593	B2	9/2009	Aferzon	
6,964,665	B2	11/2005	Thomas et al.	7,591,839	B2	9/2009	Biedermann et al.	
6,964,667	B2	11/2005	Shaolian et al.	7,601,166	B2	10/2009	Biedermann et al.	
6,966,910	B2	11/2005	Ritland	7,604,656	B2	10/2009	Shluzas	
6,974,460	B2	12/2005	Carbone et al.	7,611,518	B2	11/2009	Walder et al.	
6,979,334	B2	12/2005	Dalton	7,615,068	B2	11/2009	Timm et al.	
6,981,973	B2	1/2006	McKinley	7,621,941	B2	11/2009	Schlapfer et al.	
6,986,771	B2	1/2006	Paul et al.	7,625,394	B2	12/2009	Molz, IV et al.	
6,989,011	B2	1/2006	Paul et al.	7,641,674	B2	1/2010	Young	
6,991,632	B2	1/2006	Ritland	7,645,294	B2	1/2010	Kalfas et al.	
RE39,035	E	3/2006	Finn et al.	7,648,522	B2	1/2010	David	
7,008,424	B2	3/2006	Teitelbaum	2001/0001119	A1	5/2001	Lombardo	
7,018,378	B2	3/2006	Biedermann et al.	2001/0037111	A1	11/2001	Dixon et al.	
7,018,379	B2	3/2006	Drewry et al.	2002/0007184	A1	1/2002	Ogilvie et al.	
				2002/0013586	A1	1/2002	Justis et al.	
				2002/0026193	A1	2/2002	Barker et al.	
				2002/0035366	A1	3/2002	Walder et al.	

(56)		References Cited					
		U.S. PATENT DOCUMENTS					
2002/0045898	A1	4/2002	Freid et al.	2005/0070899	A1	3/2005	Doubler et al.
2002/0058942	A1	5/2002	Biedermann et al.	2005/0080415	A1	4/2005	Keyer et al.
2002/0072751	A1	6/2002	Jackson	2005/0085812	A1	4/2005	Sherman et al.
2002/0082602	A1	6/2002	Biedermann et al.	2005/0085815	A1	4/2005	Harms et al.
2002/0111626	A1	8/2002	Ralph et al.	2005/0085816	A1	4/2005	Michelson
2002/0133154	A1	9/2002	Saint Martin	2005/0096652	A1	5/2005	Burton
2002/0133158	A1	9/2002	Saint Martin	2005/0096653	A1	5/2005	Doubler
2002/0133159	A1	9/2002	Jackson	2005/0096654	A1	5/2005	Lin
2002/0143341	A1	10/2002	Biedermann	2005/0107788	A1	5/2005	Beaurain et al.
2002/0173789	A1	11/2002	Howland	2005/0113927	A1	5/2005	Malek
2002/0193795	A1	12/2002	Gertzbein et al.	2005/0124991	A1	6/2005	Jahng
2003/0004512	A1	1/2003	Farris et al.	2005/0131404	A1	6/2005	Mazda et al.
2003/0023240	A1	1/2003	Amrein et al.	2005/0131407	A1	6/2005	Sicvol et al.
2003/0023243	A1	1/2003	Biedermann et al.	2005/0131413	A1	6/2005	O'Driscoll et al.
2003/0028191	A1	2/2003	Shluzas	2005/0137597	A1	6/2005	Butler et al.
2003/0073996	A1	4/2003	Doubler et al.	2005/0143737	A1	6/2005	Pafford et al.
2003/0083657	A1	5/2003	Drewry et al.	2005/0143823	A1	6/2005	Boyd et al.
2003/0093078	A1	5/2003	Ritland	2005/0149020	A1	7/2005	Jahng
2003/0100896	A1	5/2003	Biedermann et al.	2005/0149023	A1	7/2005	Ritland
2003/0105460	A1	6/2003	Crandall et al.	2005/0154389	A1	7/2005	Selover et al.
2003/0109880	A1	6/2003	Shirado et al.	2005/0154390	A1	7/2005	Biedermann et al.
2003/0114852	A1	6/2003	Biedermann et al.	2005/0154391	A1	7/2005	Doherty et al.
2003/0125741	A1	7/2003	Biedermann et al.	2005/0159750	A1	7/2005	Doherty
2003/0149432	A1	8/2003	Frigg et al.	2005/0165400	A1	7/2005	Fernandez
2003/0153911	A1	8/2003	Shluzas	2005/0171540	A1	8/2005	Lim et al.
2003/0163133	A1	8/2003	Altarac et al.	2005/0171542	A1	8/2005	Biedermann et al.
2003/0171749	A1	9/2003	Le Couedic et al.	2005/0171543	A1	8/2005	Timm et al.
2003/0176862	A1	9/2003	Taylor et al.	2005/0177157	A1	8/2005	Jahng
2003/0191470	A1	10/2003	Ritland	2005/0182401	A1	8/2005	Timm et al.
2003/0199873	A1	10/2003	Richelsoph	2005/0182410	A1	8/2005	Jackson
2003/0208204	A1	11/2003	Bailey et al.	2005/0187548	A1	8/2005	Butler et al.
2003/0216735	A1	11/2003	Altarac et al.	2005/0187555	A1	8/2005	Biedermann et al.
2003/0220642	A1	11/2003	Freudiger	2005/0192580	A1	9/2005	Dalton
2003/0220643	A1	11/2003	Ferree	2005/0203511	A1	9/2005	Wilson-MacDonald et al.
2004/0002708	A1	1/2004	Ritland	2005/0203513	A1	9/2005	Jahng et al.
2004/0006342	A1	1/2004	Altarac et al.	2005/0203514	A1	9/2005	Jahng et al.
2004/0049189	A1	3/2004	Le Couedic et al.	2005/0203516	A1	9/2005	Biedermann et al.
2004/0049190	A1	3/2004	Biedermann et al.	2005/0203517	A1	9/2005	Jahng et al.
2004/0073215	A1	4/2004	Carli	2005/0203518	A1	9/2005	Biedermann et al.
2004/0078082	A1	4/2004	Lange	2005/0203519	A1	9/2005	Harms et al.
2004/0087949	A1	5/2004	Bono et al.	2005/0216001	A1	9/2005	David
2004/0087952	A1	5/2004	Borgstrom et al.	2005/0216003	A1	9/2005	Biedermann et al.
2004/0092934	A1	5/2004	Howland	2005/0228379	A1	10/2005	Jackson
2004/0097933	A1	5/2004	Lourdel et al.	2005/0228501	A1	10/2005	Miller et al.
			A61B 17/7032	2005/0234450	A1	10/2005	Barker
			606/266	2005/0234451	A1	10/2005	Markworth
				2005/0234452	A1	10/2005	Malandain
				2005/0234453	A1	10/2005	Shaolian et al.
				2005/0234454	A1	10/2005	Chin
				2005/0234456	A1	10/2005	Malandain
2004/0116929	A1	6/2004	Barker et al.	2005/0240181	A1	10/2005	Boomer et al.
2004/0138662	A1	7/2004	Landry et al.	2005/0240183	A1	10/2005	Vaughan
2004/0143265	A1	7/2004	Landry et al.	2005/0245930	A1	11/2005	Timm et al.
2004/0147928	A1	7/2004	Landry et al.	2005/0251137	A1	11/2005	Ball
2004/0147929	A1	7/2004	Biedermann et al.	2005/0251140	A1	11/2005	Shaolian et al.
2004/0153068	A1	8/2004	Janowski	2005/0251141	A1	11/2005	Frigg et al.
2004/0158247	A1	8/2004	Sitiso et al.	2005/0260058	A1	11/2005	Cassagne, III
2004/0162560	A1	8/2004	Raynor et al.	2005/0261685	A1	11/2005	Fortin et al.
2004/0172022	A1	9/2004	Landry et al.	2005/0261687	A1	11/2005	Garamszegi et al.
2004/0172032	A1	9/2004	Jackson	2005/0267470	A1	12/2005	McBride
2004/0176766	A1	9/2004	Shluzas	2005/0267471	A1	12/2005	Biedermann et al.
2004/0186473	A1	9/2004	Cournoyer et al.	2005/0267474	A1	12/2005	Dalton
2004/0193160	A1*	9/2004	Richelsoph	2005/0273099	A1	12/2005	Baccelli et al.
			A61B 17/7032	2005/0273101	A1	12/2005	Schumacher
			606/266	2005/0277919	A1	12/2005	Slivka et al.
				2005/0277922	A1	12/2005	Trieu et al.
				2005/0277923	A1	12/2005	Sweeney
				2005/0277925	A1	12/2005	Mujwid
				2005/0277927	A1	12/2005	Guenther et al.
				2005/0277928	A1	12/2005	Boschert
				2005/0283152	A1	12/2005	Lindemann et al.
				2005/0283157	A1	12/2005	Coates et al.
				2005/0283238	A1	12/2005	Reiley
				2005/0283244	A1	12/2005	Gordon et al.
				2005/0288669	A1	12/2005	Abdou
				2005/0288670	A1	12/2005	Panjabi
				2005/0288671	A1	12/2005	Yuan et al.
				2005/0288672	A1	12/2005	Ferree
				2005/0288673	A1	12/2005	Catbagan et al.

(56)

References Cited

U.S. PATENT DOCUMENTS

2006/0004357	A1	1/2006	Lee et al.	2006/0155278	A1	7/2006	Warnick
2006/0004359	A1	1/2006	Kramer et al.	2006/0161152	A1	7/2006	Ensign et al.
2006/0004360	A1	1/2006	Kramer et al.	2006/0167455	A1	7/2006	Clement et al.
2006/0004363	A1	1/2006	Brockmeyer et al.	2006/0173454	A1	8/2006	Spitler et al.
2006/0009767	A1	1/2006	Kiester	2006/0173456	A1	8/2006	Hawkes et al.
2006/0009768	A1	1/2006	Ritland	2006/0184171	A1	8/2006	Biedermann
2006/0009769	A1	1/2006	Lieberman	2006/0184180	A1	8/2006	Augustino
2006/0009770	A1	1/2006	Speirs et al.	2006/0189984	A1	8/2006	Fallin
2006/0009846	A1	1/2006	Trieu et al.	2006/0189985	A1	8/2006	Lewis
2006/0015099	A1	1/2006	Cannon et al.	2006/0195090	A1	8/2006	Suddaby
2006/0015104	A1	1/2006	Dalton	2006/0195093	A1	8/2006	Jahng
2006/0025767	A1	2/2006	Khalili	2006/0195098	A1	8/2006	Schumacher
2006/0025768	A1	2/2006	Iott et al.	2006/0200128	A1	9/2006	Mueller
2006/0025770	A1	2/2006	Schlapfer et al.	2006/0200130	A1	9/2006	Hawkins
2006/0025771	A1	2/2006	Jackson	2006/0200131	A1	9/2006	Chao et al.
2006/0036240	A1	2/2006	Colleran et al.	2006/0200149	A1	9/2006	Hoy et al.
2006/0036242	A1	2/2006	Nilsson et al.	2006/0212033	A1	9/2006	Rothman
2006/0036244	A1	2/2006	Spitler et al.	2006/0212034	A1	9/2006	Triplett et al.
2006/0036246	A1	2/2006	Carl et al.	2006/0217716	A1	9/2006	Baker et al.
2006/0036252	A1	2/2006	Baynham et al.	2006/0229608	A1	10/2006	Foster
2006/0036256	A1	2/2006	Carl et al.	2006/0229609	A1	10/2006	Wang
2006/0036259	A1	2/2006	Carl et al.	2006/0229612	A1	10/2006	Rothman
2006/0036323	A1	2/2006	Carl et al.	2006/0229613	A1	10/2006	Timm
2006/0036324	A1	2/2006	Sachs et al.	2006/0229614	A1	10/2006	Foley et al.
2006/0041259	A1	2/2006	Paul et al.	2006/0229615	A1	10/2006	Abdou
2006/0052780	A1	3/2006	Errico et al.	2006/0235389	A1	10/2006	Albert et al.
2006/0052783	A1	3/2006	Dant et al.	2006/0235392	A1	10/2006	Hammer et al.
2006/0052784	A1	3/2006	Dant et al.	2006/0235393	A1	10/2006	Bono et al.
2006/0052786	A1	3/2006	Dant et al.	2006/0241593	A1	10/2006	Sherman et al.
2006/0058788	A1	3/2006	Hammer et al.	2006/0241595	A1	10/2006	Molz, IV et al.
2006/0058790	A1	3/2006	Carl et al.	2006/0241599	A1	10/2006	Konieczynski et al.
2006/0064090	A1	3/2006	Park	2006/0241600	A1	10/2006	Ensign et al.
2006/0064091	A1	3/2006	Ludwig et al.	2006/0241769	A1	10/2006	Gordon
2006/0064092	A1	3/2006	Howland	2006/0241771	A1	10/2006	Gordon
2006/0069390	A1	3/2006	Frigg	2006/0247624	A1	11/2006	Banouskou et al.
2006/0074419	A1	4/2006	Taylor et al.	2006/0247631	A1	11/2006	Ahn et al.
2006/0079894	A1	4/2006	Colleran et al.	2006/0247632	A1	11/2006	Winslow
2006/0079895	A1	4/2006	McLeer	2006/0247633	A1	11/2006	Winslow
2006/0079896	A1	4/2006	Kwak et al.	2006/0247635	A1	11/2006	Gordon
2006/0079898	A1	4/2006	Ainsworth	2006/0247636	A1	11/2006	Yuan et al.
2006/0079899	A1	4/2006	Ritland	2006/0247637	A1	11/2006	Colleran
2006/0084981	A1	4/2006	Shluzas	2006/0247779	A1	11/2006	Gordon et al.
2006/0084982	A1	4/2006	Kim	2006/0264933	A1	11/2006	Baker et al.
2006/0084983	A1	4/2006	Kim	2006/0264936	A1	11/2006	Partin et al.
2006/0084984	A1	4/2006	Kim	2006/0264937	A1	11/2006	White
2006/0084985	A1	4/2006	Kim	2006/0264940	A1	11/2006	Hartmann
2006/0084987	A1	4/2006	Kim	2006/0271051	A1	11/2006	Berrevoets et al.
2006/0084988	A1	4/2006	Kim	2006/0276787	A1	12/2006	Zubok et al.
2006/0084989	A1	4/2006	Dickinson et al.	2006/0276789	A1	12/2006	Jackson
2006/0084991	A1	4/2006	Borgstrom	2006/0276791	A1	12/2006	Shluzas
2006/0084993	A1	4/2006	Landry et al.	2006/0276792	A1	12/2006	Ensign et al.
2006/0084995	A1	4/2006	Biedermann et al.	2006/0282074	A1	12/2006	Renaud et al.
2006/0085069	A1	4/2006	Kim	2006/0282075	A1	12/2006	Labrom
2006/0089643	A1	4/2006	Mujwid	2006/0282076	A1	12/2006	Labrom
2006/0089644	A1	4/2006	Felix	2006/0282077	A1	12/2006	Labrom
2006/0095037	A1	5/2006	Jones et al.	2006/0282078	A1	12/2006	Labrom
2006/0100621	A1	5/2006	Jackson	2006/0282079	A1	12/2006	Labrom
2006/0106380	A1	5/2006	Colleran et al.	2006/0282080	A1	12/2006	Albert
2006/0106381	A1	5/2006	Ferree	2006/0293657	A1	12/2006	Hartmann
2006/0106383	A1	5/2006	Biedermann et al.	2006/0293659	A1	12/2006	Alvarez
2006/0116677	A1	6/2006	Burd et al.	2006/0293663	A1	12/2006	Walkenhorst
2006/0122599	A1	6/2006	Drewry	2006/0293665	A1	12/2006	Shluzas
2006/0129147	A1	6/2006	Biedermann et al.	2006/0293666	A1	12/2006	Matthis et al.
2006/0129149	A1	6/2006	Iott et al.	2007/0005062	A1	1/2007	Lange
2006/0129239	A1	6/2006	Kwak	2007/0005063	A1	1/2007	Bruneau
2006/0142758	A1	6/2006	Petit	2007/0005137	A1	1/2007	Kwak
2006/0142760	A1	6/2006	McDonnell	2007/0016188	A1	1/2007	Boehm, Jr. et al.
2006/0142761	A1	6/2006	Landry et al.	2007/0016190	A1	1/2007	Martinez
2006/0149228	A1	7/2006	Schlapfer	2007/0016193	A1	1/2007	Ritland
2006/0149229	A1	7/2006	Kwak	2007/0016198	A1	1/2007	Boehm, Jr. et al.
2006/0149232	A1	7/2006	Sasing	2007/0016200	A1	1/2007	Jackson
2006/0149238	A1	7/2006	Sherman et al.	2007/0021750	A1	1/2007	Shluzas et al.
2006/0149241	A1	7/2006	Richelsof et al.	2007/0043355	A1	2/2007	Bette et al.
2006/0149244	A1	7/2006	Amrein et al.	2007/0043356	A1	2/2007	Timm
2006/0155277	A1	7/2006	Metz-Stavenhagen	2007/0043357	A1	2/2007	Kirschman
				2007/0043358	A1	2/2007	Molz, IV et al.
				2007/0043359	A1	2/2007	Altarac et al.
				2007/0043364	A1	2/2007	Cawley et al.
				2007/0049933	A1	3/2007	Ahn et al.

(56)		References Cited					
		U.S. PATENT DOCUMENTS					
2007/0049936	A1	3/2007	Colleran	2007/0233094	A1	10/2007	Colleran et al.
2007/0055235	A1	3/2007	Janowski et al.	2007/0233095	A1	10/2007	Schlaepfer
2007/0055238	A1	3/2007	Biedermann et al.	2007/0250061	A1	10/2007	Chin et al.
2007/0055239	A1	3/2007	Sweeney et al.	2007/0260246	A1	11/2007	Biedermann
2007/0055240	A1	3/2007	Matthis et al.	2007/0270806	A1	11/2007	Foley et al.
2007/0055241	A1	3/2007	Matthis et al.	2007/0270807	A1	11/2007	Armstrong et al.
2007/0055242	A1	3/2007	Bailly	2007/0270810	A1	11/2007	Sanders
2007/0055244	A1	3/2007	Jackson	2007/0270813	A1	11/2007	Garamszegi
2007/0055247	A1	3/2007	Jahng	2007/0270815	A1	11/2007	Johnson et al.
2007/0073289	A1	3/2007	Kwak	2007/0270830	A1	11/2007	Morrison
2007/0073291	A1	3/2007	Cordaro et al.	2007/0270831	A1	11/2007	Dewey et al.
2007/0073293	A1	3/2007	Martz	2007/0270832	A1	11/2007	Moore
2007/0078460	A1	4/2007	Frigg et al.	2007/0270835	A1	11/2007	Wisnewski
2007/0078461	A1	4/2007	Shluzas	2007/0270839	A1*	11/2007	Jeon et al. A61B 17/7032 606/328
2007/0083199	A1	4/2007	Baccelli	2007/0288004	A1	12/2007	Alvarez
2007/0088357	A1	4/2007	Johnson et al.	2008/0009862	A1	1/2008	Hoffman
2007/0088359	A1	4/2007	Woods et al.	2008/0009864	A1	1/2008	Forton et al.
2007/0093813	A1	4/2007	Callahan et al.	2008/0015578	A1	1/2008	Erickson et al.
2007/0093814	A1	4/2007	Callahan, II et al.	2008/0015579	A1	1/2008	Whipple
2007/0093815	A1	4/2007	Callahan, II et al.	2008/0015580	A1	1/2008	Chao
2007/0093817	A1	4/2007	Barrus et al.	2008/0015584	A1	1/2008	Richelsoph
2007/0093818	A1	4/2007	Biedermann et al.	2008/0015586	A1	1/2008	Krishna et al.
2007/0093819	A1	4/2007	Albert	2008/0021454	A1	1/2008	Chao et al.
2007/0093826	A1	4/2007	Hawkes et al.	2008/0021455	A1	1/2008	Chao et al.
2007/0093827	A1	4/2007	Warnick	2008/0021462	A1	1/2008	Trieu
2007/0093831	A1	4/2007	Abdelgany et al.	2008/0021464	A1	1/2008	Morin et al.
2007/0100341	A1	5/2007	Reglos et al.	2008/0021473	A1	1/2008	Butler et al.
2007/0118117	A1	5/2007	Altarac et al.	2008/0027432	A1	1/2008	Strauss et al.
2007/0118118	A1	5/2007	Kwak et al.	2008/0039838	A1	2/2008	Landry et al.
2007/0118119	A1	5/2007	Hestad	2008/0039843	A1	2/2008	Abdou
2007/0118122	A1	5/2007	Butler et al.	2008/0045951	A1	2/2008	Fanger et al.
2007/0118123	A1	5/2007	Strausbaugh et al.	2008/0045955	A1	2/2008	Berrevoets et al.
2007/0118124	A1	5/2007	Biedermann et al.	2008/0045957	A1	2/2008	Landry et al.
2007/0123862	A1	5/2007	Warnick	2008/0051780	A1	2/2008	Vaidya et al.
2007/0123864	A1	5/2007	Walder et al.	2008/0058811	A1	3/2008	Alleyne et al.
2007/0123865	A1	5/2007	Schlapfer et al.	2008/0058812	A1	3/2008	Zehnder
2007/0123866	A1	5/2007	Gerbec et al.	2008/0065073	A1	3/2008	Perriello et al.
2007/0123867	A1	5/2007	Kirschman	2008/0065075	A1	3/2008	Dant
2007/0123870	A1	5/2007	Jeon et al.	2008/0065077	A1	3/2008	Ferree
2007/0123871	A1	5/2007	Jahng	2008/0071273	A1	3/2008	Hawkes et al.
2007/0129729	A1	6/2007	Petit et al.	2008/0071274	A1	3/2008	Enisgn
2007/0135815	A1	6/2007	Gerbec et al.	2008/0071277	A1	3/2008	Warnick
2007/0161986	A1	7/2007	Levy	2008/0077139	A1	3/2008	Landry et al.
2007/0161991	A1	7/2007	Altarac et al.	2008/0086131	A1	4/2008	Daly et al.
2007/0161994	A1	7/2007	Lowrey et al.	2008/0086132	A1	4/2008	Biedermann et al.
2007/0161995	A1	7/2007	Trautwein et al.	2008/0097441	A1	4/2008	Hayes et al.
2007/0161996	A1	7/2007	Biedermann et al.	2008/0097457	A1	4/2008	Warnick
2007/0161997	A1	7/2007	Thramann et al.	2008/0108992	A1	5/2008	Barry et al.
2007/0161999	A1	7/2007	Biedermann et al.	2008/0119858	A1	5/2008	Potash
2007/0167948	A1	7/2007	Abdou	2008/0140075	A1	6/2008	Ensign et al.
2007/0167949	A1	7/2007	Altarac et al.	2008/0161859	A1	7/2008	Nilsson
2007/0173818	A1	7/2007	Hestad et al.	2008/0161863	A1	7/2008	Arnold et al.
2007/0173819	A1	7/2007	Sandlin	2008/0177321	A1	7/2008	Drewry et al.
2007/0173820	A1	7/2007	Trieu	2008/0177322	A1	7/2008	Davis et al.
2007/0173822	A1	7/2007	Bruneau et al.	2008/0177332	A1	7/2008	Reiley et al.
2007/0173828	A1	7/2007	Firkins et al.	2008/0183215	A1	7/2008	Altarac et al.
2007/0173832	A1	7/2007	Tebbe et al.	2008/0183223	A1	7/2008	Jeon et al.
2007/0191839	A1	8/2007	Justis et al.	2008/0195159	A1	8/2008	Kloss et al.
2007/0191841	A1	8/2007	Justis et al.	2008/0200956	A1	8/2008	Beckwith et al.
2007/0191846	A1	8/2007	Bruneau et al.	2008/0215095	A1	9/2008	Biedermann et al.
2007/0198014	A1	8/2007	Graf et al.	2008/0228229	A1	9/2008	Walder et al.
2007/0208344	A1	9/2007	Young	2008/0234734	A1	9/2008	Walder et al.
2007/0213720	A1	9/2007	Gordon et al.	2008/0234756	A1	9/2008	Sutcliffe et al.
2007/0225707	A1	9/2007	Wisnewski et al.	2008/0234759	A1	9/2008	Marino
2007/0225708	A1	9/2007	Biedermann et al.	2008/0249570	A1	10/2008	Carson et al.
2007/0225710	A1	9/2007	Jahng et al.	2008/0262548	A1	10/2008	Lange et al.
2007/0225711	A1	9/2007	Ensign	2008/0262556	A1	10/2008	Jacofsky et al.
2007/0233073	A1	10/2007	Wisnewski et al.	2008/0269742	A1	10/2008	Levy et al.
2007/0233075	A1	10/2007	Dawson	2008/0269809	A1	10/2008	Garamszegi
2007/0233078	A1	10/2007	Justis et al.	2008/0287994	A1	11/2008	Perez-Cruet et al.
2007/0233080	A1	10/2007	Na et al.	2008/0288002	A1	11/2008	Crall et al.
2007/0233085	A1	10/2007	Biedermann et al.	2008/0306528	A1	12/2008	Winslow et al.
2007/0233086	A1	10/2007	Harms et al.	2008/0306533	A1	12/2008	Winslow et al.
2007/0233087	A1	10/2007	Schlapfer	2008/0306539	A1	12/2008	Cain et al.
2007/0233092	A1	10/2007	Falahee	2008/0312655	A1	12/2008	Kirschman et al.
				2008/0312692	A1	12/2008	Brennan et al.
				2008/0312696	A1	12/2008	Battlers et al.
				2008/0312701	A1	12/2008	Batters et al.

(56)

References Cited

FOREIGN PATENT DOCUMENTS

U.S. PATENT DOCUMENTS			FOREIGN PATENT DOCUMENTS		
			DE	9202745	4/1992
			DE	4425392	11/1995
			DE	19507141	9/1996
			DE	19509331	9/1996
			DE	29806563	7/1998
			DE	28910798	12/1999
			DE	29810798	12/1999
			DE	19951145	5/2001
			DE	10157969	2/2003
			EP	0195455	9/1986
			EP	0172130	2/1987
			EP	0276153	7/1988
			EP	0465158	1/1992
			EP	0667127	8/1995
			EP	0677277	10/1995
			EP	0885598	12/1998
			EP	1090595	4/2001
			EP	1121902	8/2001
			EP	1190678	3/2002
			EP	1210914	6/2002
			EP	1277444	1/2003
			EP	1449486	8/2004
			EP	1570795	9/2005
			EP	1579816	9/2005
			EP	1634537	3/2006
			EP	1925263	5/2008
			FR	2467312	4/1981
			FR	2717370	9/1995
			FR	2718946	10/1995
			FR	2729291	7/1996
			FR	2796545	1/2001
			FR	2799949	4/2001
			FR	2856578	6/2003
			FR	2865373	1/2004
			FR	2865375	1/2004
			FR	2865377	1/2004
			FR	2857850	4/2004
			FR	2865378	10/2004
			FR	2925288	6/2009
			GB	203508	9/1923
			GB	2082709	3/1982
			GB	2140523	11/1984
			GB	9202745.8	4/1992
			GB	2365345	2/2002
			GB	2382304	5/2003
			JP	9-504727	5/1997
			JP	2000325358	3/2000
			SU	371359	8/1973
			WO	WO92/03100	3/1992
			WO	WO94/10927	5/1994
			WO	WO94/10944	5/1994
			WO	WO94/26191	11/1994
			WO	WO95/01132	1/1995
			WO	WO95/35067	12/1995
			WO	WO96/06576	3/1996
			WO	WO96/28118	9/1996
			WO	WO97/14366	4/1997
			WO	WO98/32386	7/1998
			WO	WO01/45576	6/2001
			WO	WO01/49191	7/2001
			WO	WO02/054966	7/2002
			WO	WO02/102259	12/2002
			WO	WO03/026523	4/2003
			WO	WO03/068088	8/2003
			WO	WO2004/021900	3/2004
			WO	WO2004/041100	5/2004
			WO	WO2004/075778	9/2004
			WO	WO2004/089245	10/2004
			WO	WO2004/107997	12/2004
			WO	WO2005/000136	1/2005
			WO	WO2005/000137	1/2005
			WO	WO2005/020829	3/2005
			WO	WO2005/065374	7/2005
			WO	WO2005/065375	7/2005
			WO	WO2005/072632	8/2005
			WO	WO2005/082262	9/2005
			WO	WO2005/099400	10/2005

(56)

References Cited

FOREIGN PATENT DOCUMENTS

WO	WO2005/104969	11/2005
WO	WO2006/005198	1/2006
WO	WO2006/012088	2/2006
WO	WO2006/017616	2/2006
WO	WO2006/028537	3/2006
WO	WO2006/119241	11/2006
WO	WO2007/118045	10/2007
WO	WO2007/124222	11/2007
WO	WO2007/0124249	11/2007
WO	WO2007/124249	11/2007
WO	WO2007/0130835	11/2007
WO	WO2007/130840	11/2007
WO	WO2007/130941	11/2007
WO	WO2008/088731	7/2008
WO	WO2009/015100	1/2009

OTHER PUBLICATIONS

Spine, Lipcott, Williams & Wilkins, Inc. vol. 24, No. 15, p. 1495.
EBI Omega 21 Brochure, EBI Spine Systems, pub. 1999.

Claris Instrumentation Brochure, G Med, pub. 1997.
VLS System Variable Locking Screw Brochure, Interpore Cross International, 1999.
CD Horizon M8 Multi Axial Screw Spinal System Brochure, Medtronic Sofamor Danek, no publish date.
Contour Spinal System Brochure, Ortho Development, no publish date.
Xia Spinal System Brochure, Stryker Howmedica Osteonics, no publish date.
The Rod Plate System Brochure, Stryker Howmedica Osteonics, pub. Oct. 1999.
Silhouette Spinal Fixation System Brochure, Sulzer Medica Spine—Tech, no publish date.
SDRS Surgical Dynamics Rod System Brochure, Surgical Dynamics, pub. 1998-99.
Versalok Low Back Fixation System Brochure, Wright Medical Technology, Inc., pub. 1997.
The Strength of Innovation Advertisement, Blackstone Medical Inc., no publish date.
The Moss Miami 6.0mm System Advertisement, author unknown, no publish date.

* cited by examiner

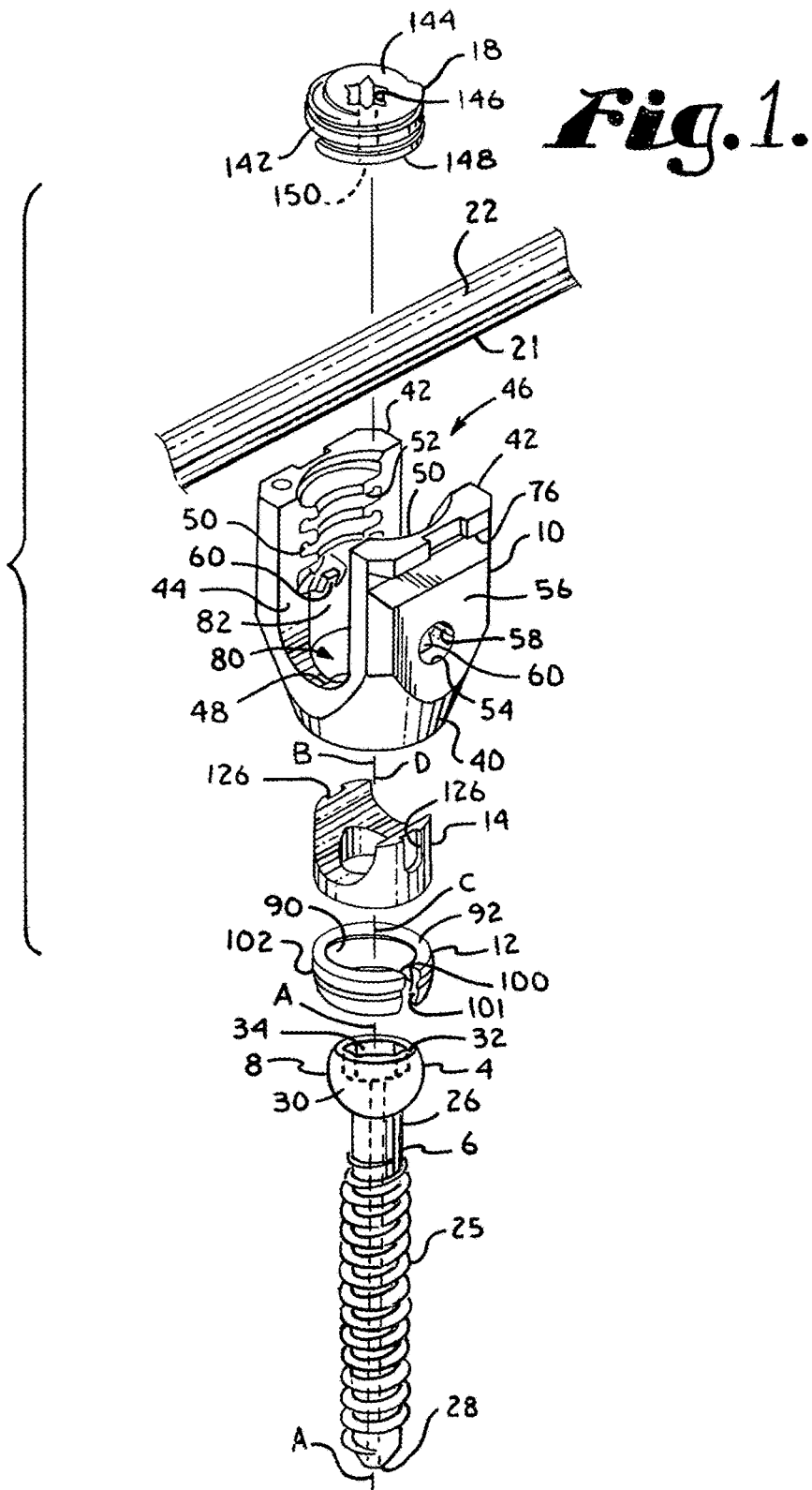

Fig. 5.

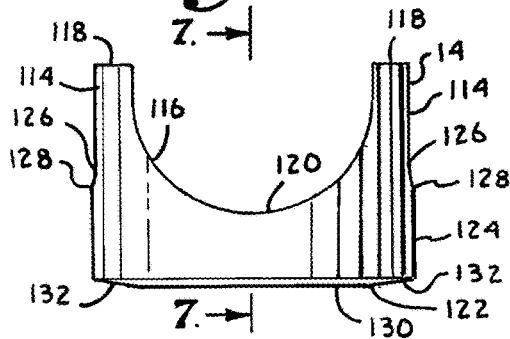

Fig. 7.

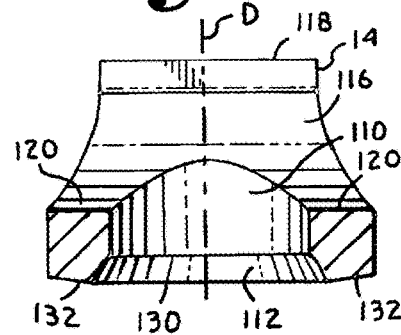

Fig. 6.

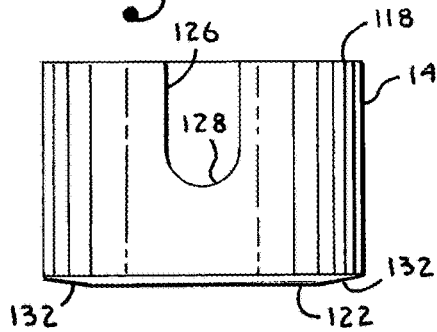

Fig. 8.

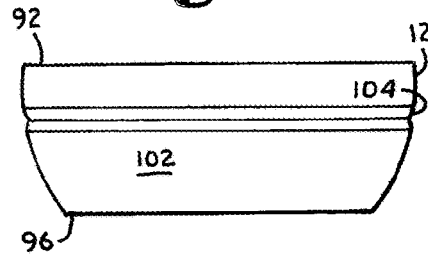

Fig. 9.

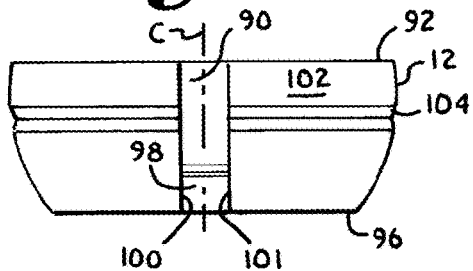
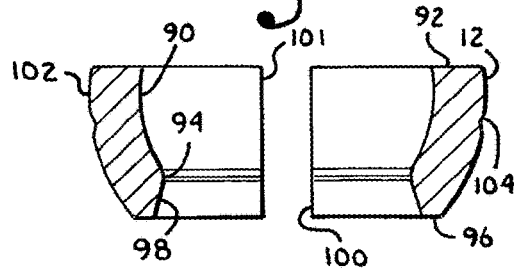

Fig. 10.



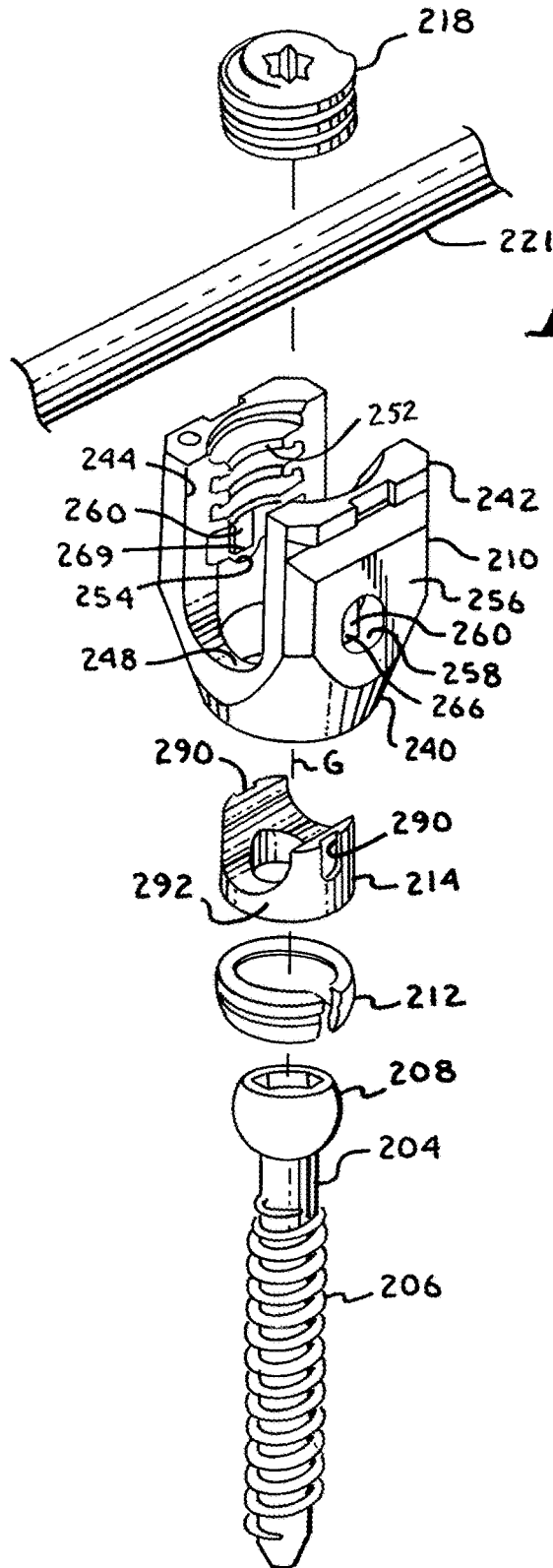

Fig. 11.

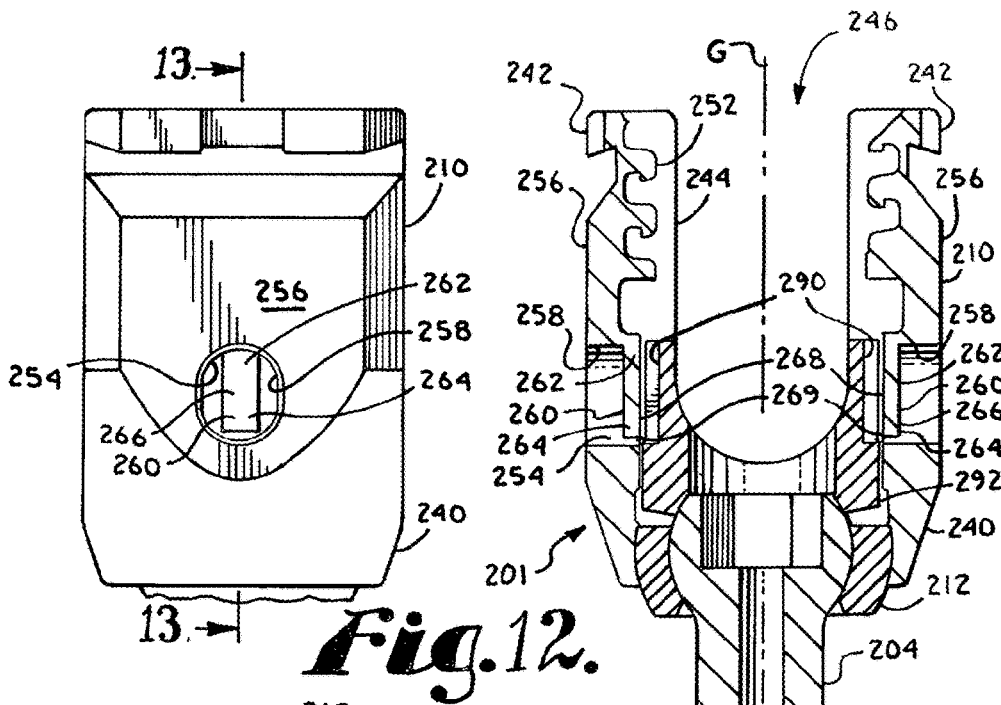

Fig. 12.

Fig. 13.

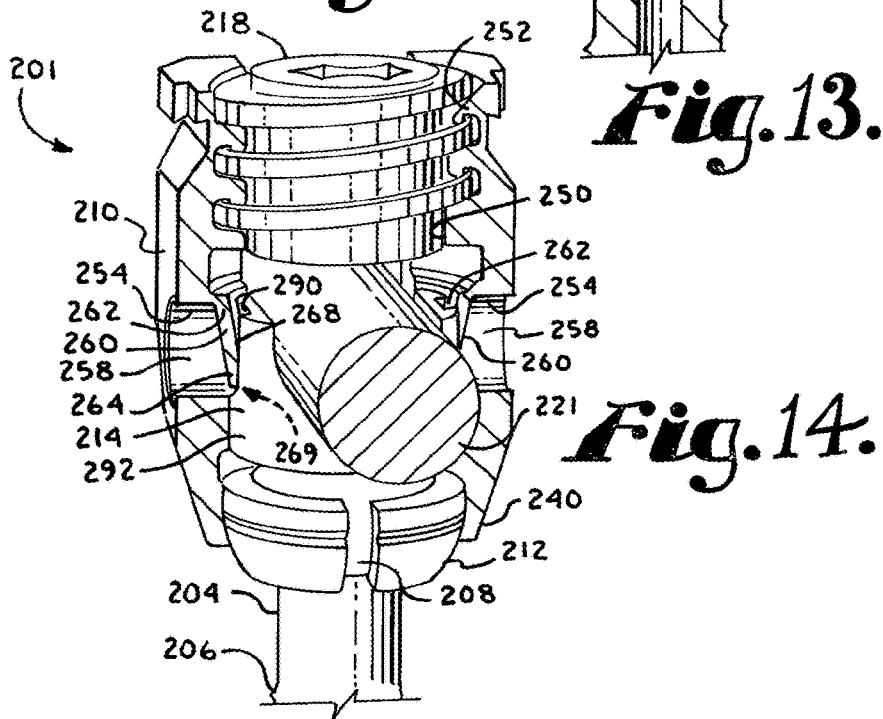
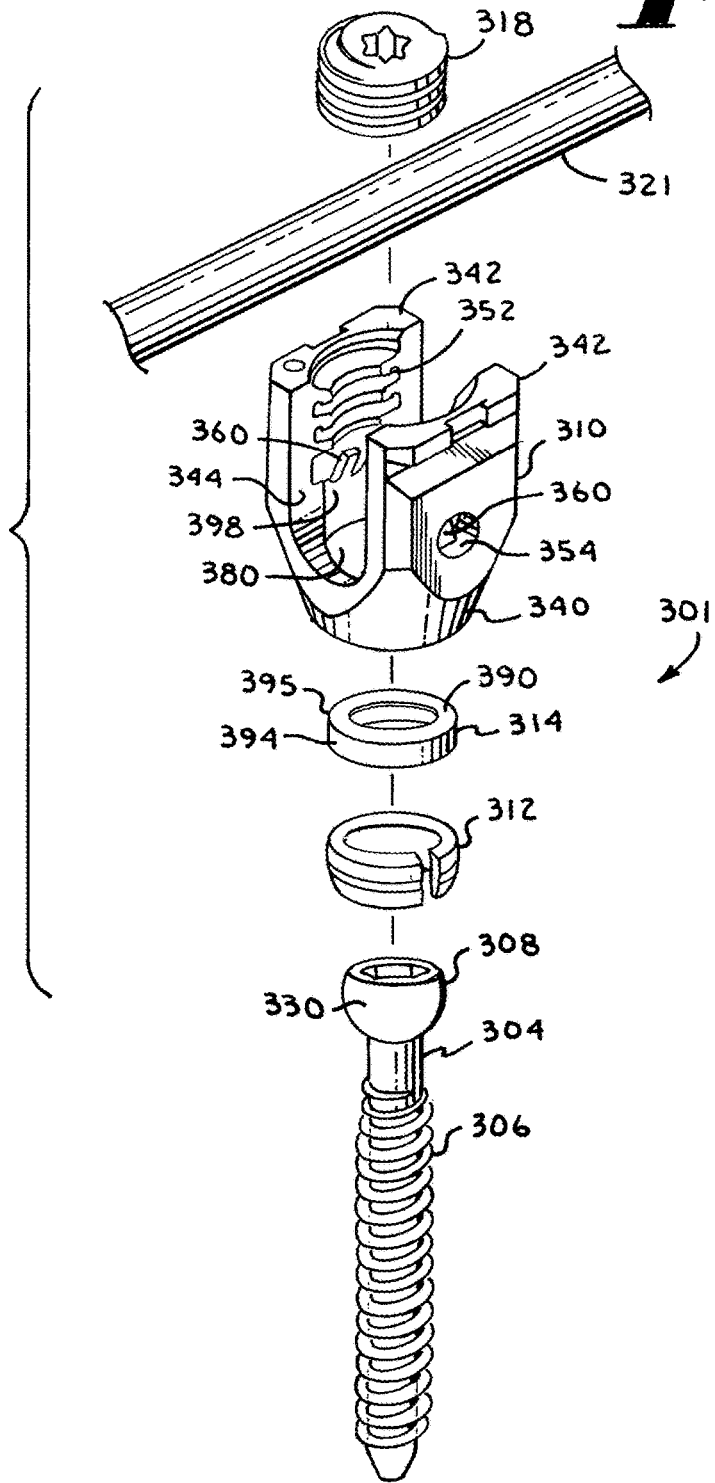

Fig. 14.

Fig. 15.



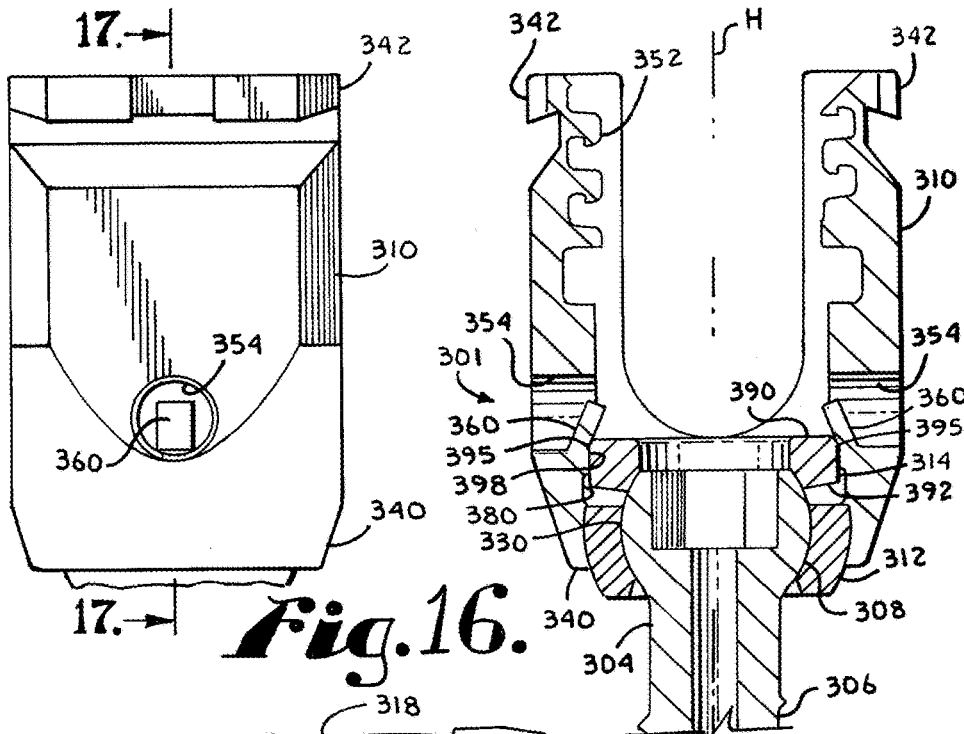

Fig. 16.

Fig. 17.

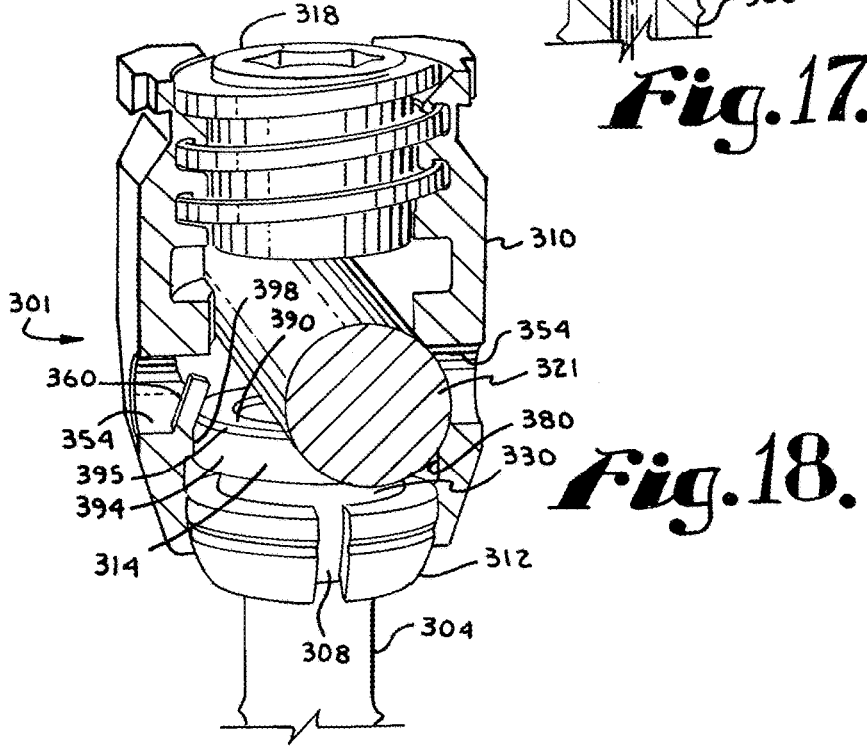

Fig. 18.

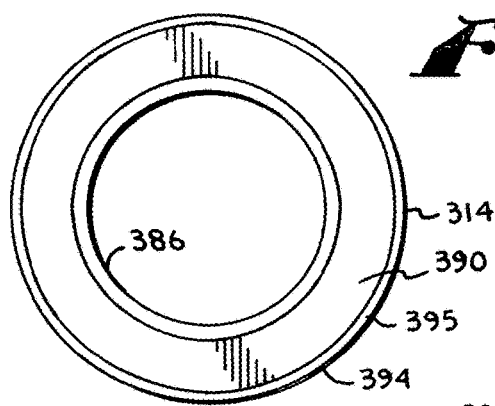

Fig. 19.

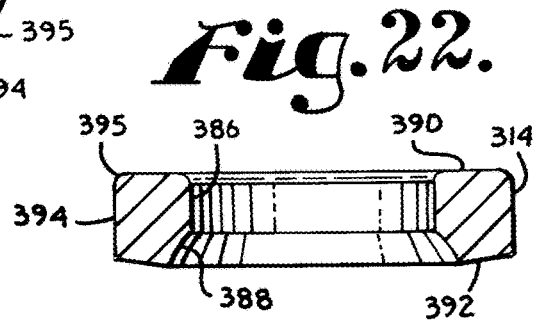

Fig. 22.

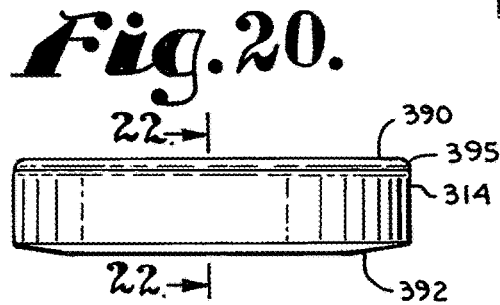

Fig. 20.

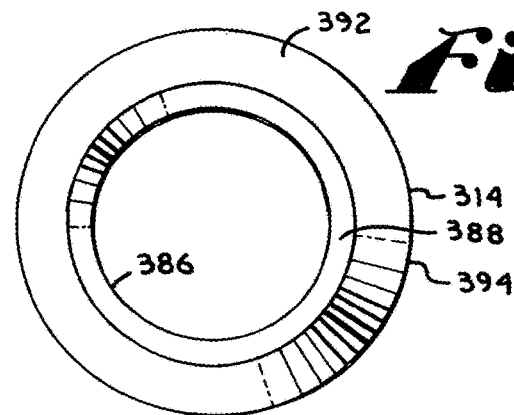

Fig. 21.

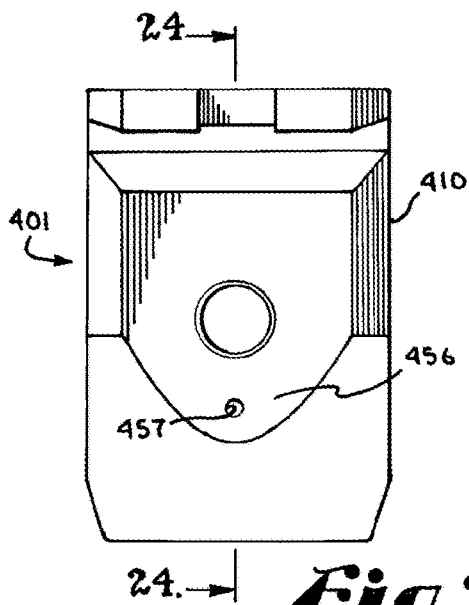

Fig. 23.

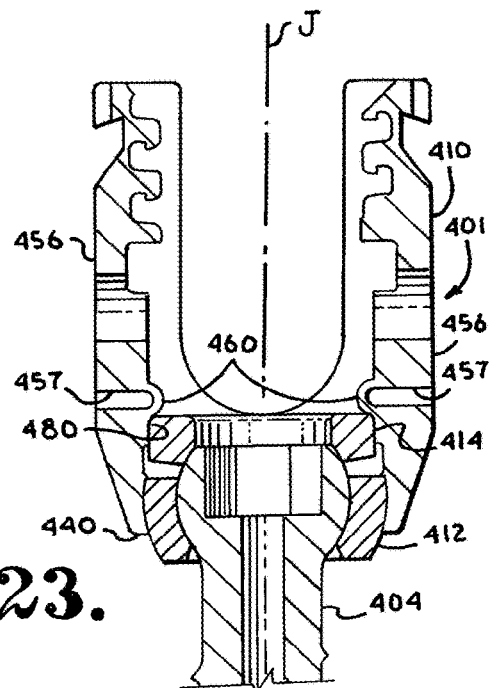
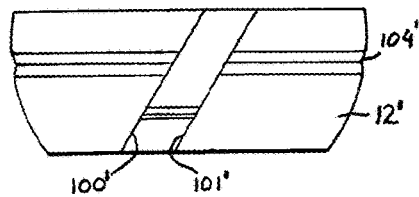

Fig. 24.

Fig. 25.



**POLYAXIAL BONE SCREW WITH
SPHERICAL CAPTURE, COMPRESSION
INSERT AND ALIGNMENT AND
RETENTION STRUCTURES**

Matter enclosed in heavy brackets [] appears in the original patent but forms no part of this reissue specification; matter printed in italics indicates the additions made by reissue; a claim printed with strikethrough indicates that the claim was canceled, disclaimed, or held invalid by a prior post-patent action or proceeding.

This application Ser. No. 15/902,433, filed on Feb. 22, 2018, is one of two reissue applications of U.S. Pat. No. 9,414,863, with the other reissue application being application Ser. No. 15/902,535 also filed on Feb. 22, 2018.

CROSS REFERENCE TO RELATED
APPLICATIONS

This application is a continuation of U.S. patent Ser. No. 12/072,354, filed Feb. 26, 2008 that claimed the benefit of U.S. Provisional Application No. 60/905,472 filed Mar. 7, 2007, both of which is incorporated by reference herein. U.S. patent Ser. No. 12/072,354 was also a continuation-in-part of U.S. patent application Ser. No. 11/126,965 filed May 10, 2005 which is incorporated by reference herein. U.S. patent Ser. No. 12/072,354 was also a continuation-in-part of U.S. patent application Ser. No. 12/008,067 filed Jan. 8, 2008 that claimed the benefit of U.S. Provisional Application No. 60/897,723 filed Jan. 26, 2007, all of which are incorporated by reference herein. This application is also a continuation-in-part of U.S. patent application Ser. No. 12/924,260, now U.S. Pat. No. 8,403,962, filed Sep. 23, 2010 that was a continuation-in-part of U.S. patent application Ser. No. 11/385,957, filed Mar. 21, 2006, that was a continuation-in-part of U.S. patent application Ser. No. 11/178,854 filed Jul. 11, 2005, now U.S. Pat. No. 7,789,896, that claimed the benefit of U.S. Provisional Application No. 60/655,239 filed Feb. 22, 2005.

BACKGROUND OF THE INVENTION

The present invention is directed to polyaxial bone screws for use in bone surgery, particularly spinal surgery, and particularly to capture structures and inserts for such screws.

Bone screws are utilized in many types of spinal surgery in order to secure various implants to vertebrae along the spinal column for the purpose of stabilizing and/or adjusting spinal alignment. Although both closed-ended and open-ended bone screws are known, open-ended screws are particularly well suited for connections to rods and connector arms, because such rods or arms do not need to be passed through a closed bore, but rather can be laid or urged into an open channel within a receiver or head of such a screw.

Typical open-ended bone screws include a threaded shank with a pair of parallel projecting branches or arms which form a yoke with a U-shaped slot or channel to receive a rod. Hooks and other types of connectors, as are used in spinal fixation techniques, may also include open ends for receiving rods or portions of other structure.

A common mechanism for providing vertebral support is to implant bone screws into certain bones which then in turn support a longitudinal structure such as a rod, or are supported by such a rod. Bone screws of this type may have a

fixed head or receiver relative to a shank thereof. In the fixed bone screws, the rod receiver head cannot be moved relative to the shank and the rod must be favorably positioned in order for it to be placed within the receiver head. This is sometimes very difficult or impossible to do. Therefore, polyaxial bone screws are commonly preferred.

Open-ended polyaxial bone screws allow rotation of the head or receiver about the shank until a desired rotational position of the head is achieved relative to the shank. Thereafter, a rod can be inserted into the head or receiver and eventually the receiver is locked or fixed in a particular position relative to the shank.

During the rod implantation process it is desirable to utilize bone screws or other bone anchors that have components that remain within the bone screw and further remain properly aligned during what is sometimes a very lengthy, difficult procedure. For example, some bone screws desirably include compression inserts or other parts that are designed to securely and fully engage surface portions of a rod or other longitudinal connecting member.

SUMMARY OF THE INVENTION

A polyaxial bone screw assembly according to the invention includes a shank having an upper portion and a body for fixation to a bone; a head or receiver defining an open channel; an articulation structure for retaining the shank upper portion within the receiver; and at least one compression insert. The articulation structure is disposed between the receiver and the shank upper portion and is slidably mated to both the upper portion and the receiver, allowing for compound articulation of the shank with respect to the receiver. The receiver includes structure cooperating with the compression insert that retain such insert in a desired position and alignment within the receiver. Illustrated embodiments include spring tabs that project into the receiver cavity either upwardly or downwardly and into grooves or slots and/or flat surfaces formed in or on the insert.

OBJECTS AND ADVANTAGES OF THE
INVENTION

Therefore, objects of the present invention include: providing an improved spinal implant assembly for implantation into vertebrae of a patient; providing such an assembly that includes an open longitudinal connecting member receiver, a shank pivotally connected to the rod receiving member, a rod or other longitudinal connecting member, and in some instances, an aligned pressure insert disposed between the shank and the rod; providing such an assembly that has a low profile after final installation; and providing such an assembly that is easy to use, especially adapted for the intended use thereof and wherein the implant assembly components are comparatively inexpensive to produce.

Other objects and advantages of this invention will become apparent from the following description taken in conjunction with the accompanying drawings wherein are set forth, by way of illustration and example, certain embodiments of this invention.

The drawings constitute a part of this specification and include exemplary embodiments of the present invention and illustrate various objects and features thereof.

BRIEF DESCRIPTION OF THE DRAWINGS

FIG. 1 is an enlarged exploded perspective view of a bone screw assembly according to the invention including a

3

shank, a retainer, a compression insert and a receiver and shown with a cooperating longitudinal connecting member and a cooperating closure top.

FIG. 2 is an enlarged and partial side elevational view of the bone screw assembly of FIG. 1.

FIG. 3 is an enlarged and partial cross-sectional view taken along the line 3-3 of FIG. 2.

FIG. 4 is an enlarged and partial perspective view of the bone screw assembly of FIG. 1 with portions broken away to show the detail thereof.

FIG. 5 is an enlarged front elevational view of the compression insert of FIG. 1.

FIG. 6 is an enlarged side elevational view of the compression insert of FIG. 1.

FIG. 7 is a cross-sectional view taken along the line 7-7 of FIG. 5.

FIG. 8 is an enlarged front elevational view of the retainer of FIG. 1.

FIG. 9 is an enlarged rear elevational view of the retainer of FIG. 1.

FIG. 10 is an enlarged front elevational view, similar to FIG. 8 with portions broken away to show the detail thereof.

FIG. 11 is an enlarged exploded perspective view of a second embodiment of a bone screw assembly according to the invention including a shank, a retainer, a compression insert and a receiver and shown with a cooperating longitudinal connecting member and a cooperating closure top.

FIG. 12 is an enlarged and partial side elevational view of the bone screw assembly of FIG. 11.

FIG. 13 is an enlarged and partial cross-sectional view taken along the line 13-13 of FIG. 12.

FIG. 14 is an enlarged and partial perspective view of the bone screw assembly of FIG. 11 with portions broken away to show the detail thereof.

FIG. 15 is an enlarged exploded perspective view of a third embodiment of a bone screw assembly according to the invention including a shank, a retainer, a compression insert and a receiver and shown with a cooperating longitudinal connecting member and a cooperating closure top.

FIG. 16 is an enlarged and partial side elevational view of the bone screw assembly of FIG. 15.

FIG. 17 is an enlarged and partial cross-sectional view taken along the line 17-17 of FIG. 16.

FIG. 18 is an enlarged and partial perspective view of the bone screw assembly of FIG. 15 with portions broken away to show the detail thereof.

FIG. 19 is an enlarged top plan view of the compression insert of FIG. 15.

FIG. 20 is an enlarged front elevational view of the compression insert of FIG. 15.

FIG. 21 is an enlarged bottom plan view of the compression insert of FIG. 15.

FIG. 22 is a cross-sectional view taken along the line 22-22 of FIG. 20.

FIG. 23 is an enlarged and partial side elevational view of a fourth embodiment of a bone screw assembly according to the invention.

FIG. 24 is an enlarged and partial cross-sectional view taken along the line 24-24 of FIG. 23 showing a shank, a retainer, a compression insert and a receiver of the assembly of FIG. 23.

FIG. 25 is an enlarged rear elevational view of an alternative embodiment of the retainer of FIG. 1 shown in FIG. 9.

4

the disclosed embodiments are merely exemplary of the invention, which may be embodied in various forms. Therefore, specific structural and functional details disclosed herein are not to be interpreted as limiting, but merely as a basis for the claims and as a representative basis for teaching one skilled in the art to variously employ the present invention in virtually any appropriately detailed structure. It is also noted that any reference to the words top, bottom, up and down, and the like, in this application refers to the alignment shown in the various drawings, as well as the normal connotations applied to such devices, and is not intended to restrict positioning of the bone attachment structures in actual use.

With reference to FIGS. 1-10, the reference numeral 1 generally designates a polyaxial bone screw assembly according to the present invention. The assembly 1 includes a shank 4 that further includes a body 6 integral with an upper portion or capture structure 8; a head or receiver 10; a retainer 12 illustrated as an open collar-like retaining and articulating structure; and a compression insert 14. The shank 4, head or receiver 10, retainer 12 and insert 14 are assembled prior to implantation of the shank body 6 into a vertebra 15.

FIG. 1 also shows a closure structure or top 18 for capturing a longitudinal connecting member within the head or receiver 10, such as a rod 21 having an outer cylindrical surface 22. Upon installation, which will be described in detail below, the closure top 18 presses against the rod 21 that in turn presses against the insert 14 that presses against the shank upper portion 8 which presses the retainer 12 into fixed frictional contact with the receiver 10, so as to fix the rod 21 relative to the bone screw 1 and thus to adjacent vertebrae. The receiver 10 and shank 4 cooperate in such a manner that the receiver 10 and shank 4 can be secured at any of a plurality of angles, articulations or rotational alignments relative to one another and within a selected range of angles both from side to side and from front to rear, to enable flexible or articulated engagement of the receiver 10 with the shank 4 until both are locked or fixed relative to each other.

The bone screw shank 4, best illustrated in FIGS. 1 and 3, is elongate, with the shank body 6 having a helically wound bone implantable thread 25 extending from near a neck 26 located adjacent to the upper portion 8 to near a tip 28 of the body 6 and extending radially outwardly therefrom. During use, the body 6 utilizing the thread 25 for gripping and advancement is implanted into a vertebra (not shown) leading with the tip 28 and driven down into the vertebra with an installation or driving tool (not shown), so as to be implanted in the vertebra to near the neck 26. The shank 4 has an elongate axis of rotation generally identified by the reference letter A.

The neck 26 extends axially upwardly from the shank body 6. Further extending axially from the neck 26 is the shank upper portion or capture structure 8 that provides a connective or capture apparatus disposed at a distance from the thread 25 and thus at a distance from the vertebra (not shown) when the body 6 is implanted in such vertebra. The shank upper portion 8 is configured for connecting the shank 4 to the receiver 10 and capturing the shank 4 in the receiver 10. The shank upper portion 8 has an outer, convex and substantially spherical surface 30 that extends outwardly and upwardly from the neck 26 and terminates at a top 32. The illustrated top 32 is substantially planar and disposed perpendicular to the axis A. The spherical surface 30 has an outer radius configured for sliding cooperation and ultimate frictional mating with a concave surface of the retainer 12

DETAILED DESCRIPTION OF THE INVENTION

As required, detailed embodiments of the present invention are disclosed herein; however, it is to be understood that

that has a substantially similar radius. The spherical surface 30 is smooth, but it is foreseen that such surface may include a roughened or textured surface or surface finish, or may be scored, knurled, or the like, for enhancing frictional engagement with the retainer 12. A counter sunk drive feature 34 is formed in the top 32 (shown as a hexagonal aperture). In operation, a driving tool (not shown) engages the feature 34 for driving the shank body 6 into bone. The drive feature 34 may take a variety of tool-engaging forms and may include one or more apertures or imprints of various shapes, such as a pair of spaced apart apertures or a multi-lobular aperture, such as those sold under the trademark TORX or the like. It is foreseen that in some embodiments, the bone screw shank upper portion may have an external tool engagement structure.

The illustrated shank 4 is cannulated, having a small central bore 35 extending an entire length of the shank 4 along the axis A, coaxial with the threaded body 6. The bore 35 has a first circular opening at the shank tip 28 and a second circular opening at the drive feature 34. The bore 35 provides a passage through the shank 4 interior for a length of wire (not shown) inserted into a vertebra (not shown) prior to the insertion of the shank body 6, the wire providing a guide for insertion of the shank body 6 into the vertebra.

To provide a biologically active interface with the bone, the threaded shank body 6 may be coated, perforated, made porous or otherwise treated. The treatment may include, but is not limited to a plasma spray coating or other type of coating of a metal or, for example, a calcium phosphate; or a roughening, perforation or indentation in the shank surface, such as by sputtering, sand blasting or acid etching, that allows for bony ingrowth or ongrowth. Certain metal coatings act as a scaffold for bone ingrowth. Bio-ceramic calcium phosphate coatings include, but are not limited to: alpha-tri-calcium phosphate and beta-tri-calcium phosphate ($\text{Ca}_3(\text{PO}_4)_2$), tetra-calcium phosphate ($\text{Ca}_4\text{P}_2\text{O}_9$), amorphous calcium phosphate and hydroxyapatite ($\text{Ca}_{10}(\text{PO}_4)_6(\text{OH})_2$). Coating with hydroxyapatite, for example, is desirable as hydroxyapatite is chemically similar to bone with respect to mineral content and has been identified as being bioactive and thus not only supportive of bone ingrowth, but actively taking part in bone bonding.

With reference to FIGS. 1-4, the receiver 10 has a generally U-shaped appearance with a discontinuous partially cylindrical and partially spherical inner profile and a partially curved and partially faceted outer profile. The receiver has an axis of rotation B that is shown in FIG. 1 as being aligned with and the same as the axis of rotation A of the shank 4, such orientation being desirable during assembly of the receiver 10 with the shank 4, the retainer 12 and the insert 14. After the receiver 10 is pivotally attached to the shank 4, and the assembly 1 is implanted in a vertebra (not shown), the axis B is typically disposed at an angle with respect to the axis A.

The receiver 10 includes a base 40 integral with a pair of opposed upstanding arms 42 forming a cradle and defining a U-shaped channel 44 between the arms 42 with an upper opening 46 and a lower seat 48, the channel 44 having a width for receiving the rod 21, for operably snugly receiving the rod 21 between the arms 42. Each of the arms 42 has an interior surface 50 that defines the inner cylindrical profile and includes a partial helically wound guide and advancement structure 52. In the illustrated embodiment, the guide and advancement structure 52 is a partial helically wound interlocking flangeform configured to mate under rotation with a similar structure on the closure structure 18, as described more fully below. However, it is foreseen that the

guide and advancement structure 52 could alternatively be a square-shaped thread, a buttress thread, a reverse angle thread or other thread like or non-thread like helically wound discontinuous advancement structure for operably guiding under rotation and advancing the closure structure 18 downward between the arms 42, as well as eventual torquing when the closure structure 18 abuts against the rod 21.

An opposed pair of tool receiving and engaging apertures 54 are formed on outer surfaces 56 of the arms 42. A pair of substantially cylindrical inner surfaces 58 define the apertures 54, with a portion of each of the apertures 54 extending through the arms 42 as best illustrated in FIG. 2. With particular reference to FIGS. 3 and 4, a pair of tabs 60, each having a lower end or body portion 62 integral with a respective arm 42 at a lower portion of one of the cylindrical surfaces 58, and an upper end 64 extending upwardly and inwardly from the respective lower body portion 62, the tab 60 generally directed towards the guide and advancement structure 52 of the respective arm 42 and also toward the axis B. As shown in FIGS. 1, 3 and 4, an operational orientation of each of the tabs 60 is angled toward the axis B with an inner surface 68 or edge 69 of the upper end 64 in sliding engagement with a slot in the cooperating insert 14 as will be described in greater detail below. The tabs 60 are typically initially disposed parallel to the axis B and then a tool (not shown) is inserted into the aperture 54 from the outside surface 56 and engages and pushes a surface 66 of the tab 60 and bends the tab 60 inwardly in a direction toward the axis B until the tab 60 is at the illustrated desired angular position. Such bending of the tabs 60 may be performed either prior to or after assembly of the receiver 10 with the insert 14, the shank 4 and the retainer 12. It is also foreseen that the tabs 60 may be machined or otherwise pre-fabricated to be angled or directed toward the axis B as is shown in the drawing figures. The illustrated tabs 60 are resilient, having a spring-like nature. Thus, when operatively cooperating with the insert 14, the tabs 60 bias against the insert 14, holding such insert in a desired position and yet the tabs 60 are flexible enough to allow a user to make desired adjustments of the position of the insert 14 within the receiver 10.

Each of the illustrated receiver arms 42 also includes a V-shaped or undercut tool engagement groove 76, formed on outer surfaces thereof which may be used for holding the receiver 10 with a holding tool (not shown) having projections that are received within the grooves 76 during implantation of the shank body 6 and/or during subsequent installation of the rod 21 or other longitudinal connecting member and the closure structure 18. It is foreseen that tool receiving grooves or apertures may be configured in a variety of shapes and sizes and be disposed at other locations on the receiver arms 42.

Communicating with the U-shaped channel 44 of the receiver 10 is a chamber or cavity 80 defined in part by a substantially cylindrical upper portion 82 and by a lower inner substantially spherical seating surface 84 of the base 40. The upper portion 82 is located below the guide and advancement structures 52 and may include one or more cylindrical surfaces for sliding cooperation with an insert or inserts. As illustrated in FIG. 3, the cylindrical upper portion 82 may include a lower section or portion 85 having a larger diameter than a remainder of the portion 82, the portion 85 located adjacent to the spherical seat 84 and providing clearance for movement of the retainer 12, including an expanding or spreading movement thereof during attachment with the shank upper portion 8 and for swiveling the

retainer 12 to a desired orientation after assembly of the bone screw 1. The apertures 54 and the tabs 60 communicate with the cylindrical upper portion 82. The seating surface 84 is near or adjacent to the cylindrical portion 82. The seating surface 84 is sized and shaped for slidable mating and eventual frictional engagement with the retainer 12, as described more fully below. The cavity 80 opens into the U-shaped channel 44 and also to a lower neck 86 defining a bore or circular opening that communicates with a lower exterior 88 of the base 40. The circular neck 86 is coaxially aligned with the rotational axis B of the receiver 10. The neck 86 is sized and shaped to be smaller than an outer radial dimension of the open, uncompressed retainer 12, as will be discussed further below, so as to form a restriction at the location of the neck relative to the retainer 12, to prevent the uncompressed retainer 12 from passing from the cavity 80 and out to the lower exterior 88 of the receiver 10 when the retainer 12 is seated and loaded.

With reference to FIGS. 1, 3, 4 and 8-10, the partially spherical and discontinuous or open retainer 12 that both retains and articulates is used to hold the spherically surfaced 30 upper portion 8 of the shank 4 within the receiver 10 and is also independently slidably and pivotally engageable with both the shank upper portion 8 at the surface 30 and the receiver 10 at the seating surface 84. The retainer 12 has an operational central axis C that may be the same or different from the axis A associated with the shank 4, or the axis B associated with the receiver 10 when the shank upper portion 8 and the retainer 12 are installed within the receiver 10. The retainer 12 has a central channel or through bore substantially defined by a discontinuous inner partially spherical surface 90. The surface 90 extends from a substantially planar annular top 92 to an inner neck 94 disposed near a substantially planar annular bottom surface 96. An inner chamfer 98 runs between the neck 94 and the bottom surface 96. The inner spherical surface 90 has a radius sized and shaped to cooperate with a radius of the substantially spherical surface 30 of the shank upper portion 8 such that the surface 90 slidingly and pivotally mates with the spherical surface 30. The surface 90 may include a roughening or surface finish to aid in frictional contact between the surface 90 and the surface 30, once a desired angle of articulation of the shank 4 with respect to the retainer 12 and also with respect to the receiver 10 is reached.

The resilient retainer 12 includes first and second end surfaces, 100 and 101 disposed in spaced relation to one another and a discontinuous outer partially spherically shaped surface 102. Both end surfaces 100 and 101 are disposed substantially perpendicular to the top surface 92 and the bottom surface 96. A width of the space between the surfaces 100 and 101 is determined to provide adequate space for the retainer 12 to be pinched, with the surfaces 100 and 101 compressed toward one another to an almost touching or touching configuration, to an extent that the compressed retainer 12 is up or bottom loadable into the receiver cavity 80 being received within the lower neck 86 opening of the receiver 10 while mounted on the neck 26 of the bone screw shank body 6. After passing through the bore defined by the lower neck 86 of the receiver 10 simultaneously with the shank upper portion 8, the retainer 12 expands or springs back to an original uncompressed, rounded or collar-like configuration of FIG. 1 once in the cavity 80. The retainer 12 is then expanded about the shank upper portion spherical surface 30 as will be described in greater detail below. Then, once the resilient structure 12 returns to an original form, but now surrounding the spherical structure 30, the engaged structures 8 and 12 are movable together

within the cavity 80 at the spherical seat 84 to a variety of positions in which the surface 102 of the retainer 12 is in slidable mating engagement with the seating surface 84 of the receiver 10.

The illustrated embodiment of the retainer 12 shows the surfaces 100 and 101 as substantially parallel and vertical, however, in other embodiments according to the invention, such as the retainer 12' shown in FIG. 25, opposing surfaces 100' and 101' are oriented obliquely or at a slight angle with respect to top and bottom surfaces thereof, advantageously allowing for the surfaces 100' and 101' to slide and ride up upon one another during assembly with the other components of the assembly 1, allowing for greater compression of the retainer 12' without increasing the space between the surfaces 100' and 101' when the retainer 12' is in an uncompressed state. Depending upon the amount of compression desired during loading of the retainer 12' into the receiver 10, the oblique angle may be modified. The retainer 12' is otherwise identical or substantially similar to the retainer 12 in form and function. Furthermore, the illustrated embodiment 12 and 12' include an outer groove 104 and 104', respectively, that may be needed in some instances for clearance within the receiver 10 when the retainer 12 or 12' is expanded about the spherical surface 30 of the shank upper portion 8. Also, other embodiments according to the invention, particularly smaller bone screw assemblies, may include retainers small enough to top load into the receiver channel upper opening 46, rather than loading through the receiver neck 86.

With reference to FIGS. 1, 3 and 4, the compression member or insert 14 is sized and shaped to be received by and uploaded into the receiver 10 at the lower neck 86. In operation, the insert 14 is disposed between the rod 21 and the upper portion 8 of the bone screw 4 as illustrated for example in FIGS. 3 and 4. When the closure structure 18 presses upon the rod 21, the rod 21 operatively presses upon the insert 14 that in turn presses upon the shank upper portion 8 that in turn presses against the retainer 12 that in turn presses against the seating surface 84 of the receiver 10, resulting in ultimate frictional engagement and locking of the angular position of the bone screw shank 4 with respect to the receiver 10. The compression insert 14 has an operational central axis D that is the same as the central axis B of the receiver 10.

With particular reference to FIGS. 5-7, the compression insert 14 has a central channel or through bore substantially defined by an inner cylindrical surface 110 and an inner partially spherical surface 112, both having the central axis D. The compression insert 14 through bore is sized and shaped to receive a driving tool (not shown) therethrough that engages the shank drive feature 34 when the shank body 6 is driven into bone. The surface 112 is sized and shaped to cooperate with the spherical surface 30 of the shank upper portion 8 such that the surface 112 slidingly and pivotally mates with the spherical surface 30. The surface 112 may include a roughening or surface finish to aid in frictional contact between the surface 112 and the surface 30, once a desired angle of articulation of the shank 4 with respect to the retainer 12 and the receiver 10 is reached.

The compression insert 14 also includes a pair of arms 114 with a U-shaped surface or saddle 116 formed therebetween. The saddle 116 defines a U-shaped channel that communicates with the bore defined by the cylindrical surface 110 and the spherical surface 112. The curved surface or saddle 116 is sized and shaped to closely receive the cylindrical rod 21. With reference to the axis D, the saddle 116 extends from top surfaces 118 of the arms to a curved lower seat 120 near a

bottom surface 122 of the insert 114. In operation, the lower seat 129 (as well as a substantial portion of a remainder of the saddle 116) frictionally engages the surface 22 of the rod 21.

A base having a cylindrical surface 124 is disposed between the saddle 116 and the bottom surface 122. The cylindrical surface 124 also extends about the arms 114. Formed in the surface 124 and located centrally with respect to each arm 114 is a shallow groove 126. Each groove 126 is U-shaped and runs from the respective top surface 118 to a curved bottom 128 located approximately centrally between the top surface 118 and the bottom surface 122. The grooves 126 are sized and shaped to cooperate with the tabs 60 of the receiver 10 as will be described in greater detail below. Thus, although the grooves 126 may be of any shape, the grooves 126 preferably are elongate, running parallel to the axis D and have a width that receives the respective tab 60 within such groove. The bottom surface 122 includes a substantially planar and annular central portion 130 disposed perpendicular to the axis D. The bottom portion 130 extends about the bore defined by the inner spherical surface 112. The bottom surface 122 further includes an outer planar and annular surface portion 132 disposed at an angle with respect to the surface portion 130. The surface portion 132 angles upwardly (toward the top surfaces 118) and outwardly (away from the axis D) from the surface 130. As shown in FIG. 3, the surface portion 132 provides clearance for articulated movement of the retainer 12 and the bone screw shank 4.

The compression or pressure insert 14 ultimately seats on the shank upper portion 8 and is disposed substantially in the upper cylindrical portion 82 of the cavity 80, with the tabs 60 holding the insert 14 in desired alignment with respect to the rod 21 as will be described in greater detail below. In operation, the insert 14 extends at least partially in the channel 44 such that the saddle 116 surface substantially contacts and engages the outer surface 22 of the rod 21 when such rod is placed in the receiver 10 and the closure structure or top 18 is tightened therein.

With reference to FIGS. 1 and 4, the closure structure or closure top 18 can be any of a variety of different types of closure structures for use in conjunction with the present invention with suitable mating structure on the upstanding arms 42. In the embodiment shown, the closure top 18 is rotatably received between the spaced arms 42, but could be a slide-in closure structure. The illustrated closure structure 18 is substantially cylindrical and includes an outer helically wound guide and advancement structure 142 in the form of a flange form that operably joins with the guide and advancement structure 52 disposed on the arms 42 of the receiver 10. The flange form utilized in accordance with the present invention may take a variety of forms, including those described in Applicant's U.S. Pat. No. 6,726,689, which is incorporated herein by reference. It is also foreseen that according to the invention the closure structure guide and advancement structure could alternatively be a buttress thread, a square thread, a reverse angle thread or other thread like or non-thread like helically wound advancement structure for operably guiding under rotation and advancing the closure structure 18 downward between the arms 42 and having such a nature as to resist splaying of the arms 42 when the closure structure 18 is advanced into the U-shaped channel 44. The illustrated closure structure 18 also includes a top surface 144 with an internal drive 146 in the form of an aperture that may be a hex drive, or as illustrated, a star-shaped internal drive, for example, sold under the trademark TORX or other internal drives such as slotted,

tri-wing, spanner, two or more apertures of various shapes, and the like. A driving tool (not shown) sized and shaped for engagement with the internal drive 146 is used for both rotatable engagement and, if needed, disengagement of the closure 18 from the receiver arms 42. It is also foreseen that the closure structure 18 may alternatively include a break-off head designed to allow such a head to break from a base of the closure at a preselected torque, for example, 70 to 140 inch pounds. Such a closure structure would also include a base having an internal drive to be used for closure removal. A bottom surface 148 of the closure may be planar or include a point, points, a rim or roughening for engagement with the surface 22 of the rod 21. The illustrated closure top 18 further includes a cannulation through bore 150 extending along a central axis thereof and through the top surface 144 and the bottom surface 148. Such a through bore provides a passage through the closure 18 interior for a length of wire (not shown) inserted therein to provide a guide for insertion of the closure top into the receiver arms 42.

Prior to the polyaxial bone screw assembly 1 being placed in use according to the invention the tabs 60 of the receiver 10 are preferably bent inwardly toward the axis B as shown in FIGS. 1, 2 and 4. This is accomplished by inserting an elongate tool (not shown) into each of the tooling apertures 54 and pressing the respective tab 60 inwardly toward the axis B until the tab end 64 is disposed at least partially within the upper cylindrical portion 82 of the cavity 80. It is noted that alternatively, in some embodiments according to the invention, the tabs 60 are bent inwardly toward the axis B after the pressure insert 14 is located in the cylindrical portion 82 of the cavity 80. For example, if the insert 14 is top loaded through the opening 46 of the receiver 10, it may be desirable to first load the insert 14 into the receiver, align the grooves 126 with the tabs 60 and then press the tabs 60 until such tabs come into frictional engagement with surfaces of the receiver 14 disposed within the shallow grooves 126.

Also prior to the polyaxial bone screw assembly 1 being placed in use according to the invention, the retainer 12 is first inserted about the neck 26 of the shank body 6 by inserting the shank tip 28 into the retainer 12 through bore defined by the inner surface 90 and feeding the shank body 6 therethrough until the retainer 12 is located at the neck 26. Alternatively, in certain embodiments, the retainer 12 is placed near the neck 26 and the end surfaces 100 and 101 are pulled away from one another and pressed against and about the neck 26 until the surfaces 100 and 101 expand around the neck 26 and then spring back into an original or first position with the inner surface 90 disposed adjacent to the neck 26 and the top surface 92 facing toward the spherical surface 30 of the shank upper portion 8.

In the illustrated embodiment, prior to inserting the shank 4 and connected retainer 12 into the receiver 10, the compression insert 14 is up or bottom loaded into the receiver 10 through the lower neck 86 with the saddle 116 facing the neck 86 and the arms 114 aligned with the tabs 60. The insert 14 is then moved upwardly through the lower seat 84 of the receiver 10 and into the cylindrical portion 82 of the cavity 80. As the insert 14 is moved upwardly into the cylindrical portion 82, each of the tabs 60 are received in a groove 126. The tabs 60 press against the insert 14 at the grooves 126, allowing for some upward and downward adjustment of the insert 14. However, rotation of the insert 14 about the axis B is prohibited by the tabs 60 abutting against surfaces forming the grooves 126. Surfaces defining the lower curved portion 128 of the grooves 126 also prohibit the tabs 60 from

11

sliding along the outer cylindrical surface 124 of the insert 14, thus resisting upward movement of the insert 14 out of the receiver 10.

In certain embodiments, it may be desirable to place the compression insert 14 on the shank upper portion 8 with the spherical surface 112 seated on the surface 30 of the shank upper portion 8 and then upload the insert 14 simultaneously with the shank upper portion 8 and the retainer 12. The upper portion 8 and the connected retainer 12 are simultaneously up or bottom-loaded into the receiver cavity 80 by inserting the upper portion 8 through the lower neck 86 and into the cavity 80 lower seat portion 84 and manually compressing the retainer 12 by pinching the surfaces 100 and 101 toward one another and inserting the neck 26 and the compressed retainer 12 into the bore formed by the lower neck 86 of the receiver 10. After the retainer 12 moves beyond the neck 86, the compressive force is removed and the retainer 12 resiliently springs back and returns to the original ring-like or collar-like orientation, capturing the shank upper portion 8 within the receiver 10. Then, the shank body 6 is pulled downwardly away from the base 40 of the receiver 10, forcing the retainer 12 to temporarily expand as the retainer 12 moves along the spherical surface 30 of the shank upper portion 8 with the end surfaces 100 and 101 moving away from one another. Such an expansion of the retainer 12 allows the spherical surface 30 to slide or snap into the retainer 12 with the spherical surfaces 30 and 90 becoming aligned and the shank upper portion 8 ultimately in sliding cooperation with the inner surface 90 of the retainer 12. The retainer 12 thus resiliently returns to the original ring-link orientation, with the spherical surface 90 capturing the shank upper portion 8 at the spherical surface 30, but allowing for pivotal movement or articulation of the shank upper portion 8 with respect to the retainer 12. Once the retainer 12 returns to the original orientation, both the connected structures 8 and 12 drop down to a seated position at the spherical surface 84 of the receiver 10, with the retainer 12 being independently slidable with respect to both the shank upper portion 8 and the receiver 10, forming a multi- or compound articulation or joint between the shank 4 and the receiver 10. The compression insert 14 may then be pressed downwardly and into full contact with the surface 30.

The retainer 12 and the attached shank upper portion 8 may then be manipulated into a substantially coaxial position with the insert 14 in readiness for bone implantation. The assembly 1 is typically screwed into a bone, such as a vertebra (not shown), by rotation of the shank 4 using a driving tool (not shown) that operably drives and rotates the shank 4 by engagement thereof with the drive feature 34.

Typically, the receiver 10, the compression or pressure insert 14, and the retainer 12 are assembled on the shank 4 before inserting the shank body 6 into a vertebra. However, in certain circumstances, such as when a small bone screw is utilized and the retainer is top loadable, the shank body 6 can be first partially implanted with the shank upper portion 8 extending proud to allow assembly with the receiver 10, followed by assembly with a top loaded retainer 12 and a top loaded compression insert 14. Then the shank body 6 can be further driven into the vertebra.

The vertebra (not shown) may be pre-drilled to minimize stressing the bone and have a guide wire (not shown) inserted to provide a guide for the placement and angle of the shank 4 with respect to the vertebra. A further tap hole may be made using a tap with the guide wire as a guide. Then, the bone screw assembly 1 or the solitary shank 4, is threaded onto the guide wire utilizing the cannulation bore

12

35 by first threading the wire into the opening at the bottom 28 and then out of the top opening at the drive feature 34. The shank 4 is then driven into the vertebra using the wire as a placement guide. It is foreseen that the bone screw assemblies 1, the rod 21 (also having a central lumen in some embodiments) and the closure top 18 can be inserted in a percutaneous or minimally invasive surgical manner, utilizing guide wires.

With reference to FIG. 4, the rod 21 is eventually positioned in an open or percutaneous manner in cooperation with the at least two bone screw assemblies 1. Alignment of the rod surface 22 with the saddle 116 of the insert 14 is initially provided and then maintained by pressure placed at the insert grooves 126 by the tabs 60. A closure structure 18 is then inserted into and advanced between the arms 42 of each of the bone screw assemblies 1. The closure structure 18 is rotated, using a tool engaged with the inner drive 146 until a selected pressure is reached at which point the rod 21 engages the saddle 116 and the rod is urged toward, but not in contact with the lower seat 48 of the receiver 10 that defines the U-shaped channel 44. For example, about 80 to about 120 inch pounds pressure may be required for fixing each bone screw shank 7 with respect to the receiver 10.

As each closure structure 18 rotates and moves downwardly into the respective receiver 10, the bottom surface 148 presses against the rod surface 22, biasing the rod into engagement with the compression insert 14 that operably produces a frictional engagement between the insert surface 112 and the shank surface 30 and also urges the shank upper portion 8 toward the retainer 12 and, in turn, the structure 12 in a direction toward the base 40 of the receiver 10, so as to frictionally seat the spherical surface 30 against the inner spherical surface 90 of the retainer 12 and the outer spherical surface 102 of the retainer 12 against the internal spherical seating surface 84 of the receiver 10, also fixing the shank 4 and the retainer 12 in a selected, rigid position relative to the receiver 10. At this time it is also possible for the retainer 12 to expand somewhat for an even tighter fit in the receiver cavity lower seat 84.

If removal of the rod 21 from any of the bone screw assemblies 1 is necessary, or if it is desired to release the rod 21 at a particular location, disassembly is accomplished by using the driving tool (not shown) that mates with the internal drive 146 on the closure structure 18 to rotate and remove the closure structure 18 from the cooperating receiver 10. Disassembly is then accomplished in reverse order to the procedure described previously herein for assembly.

With reference to FIGS. 11-14, an alternative bone screw assembly of the invention, generally 201 includes a shank 204 that further includes a body 206 integral with an upper portion or capture structure 208; a head or receiver 210; a retainer 212 illustrated as an open collar-like retaining and articulating structure; and a compression insert 214. The shank 204, the retainer 212 and the insert 214 are identical or substantially similar to the respective shank 4, retainer 12 and insert 14 previously described herein. The assembly 201 also cooperates with the rod 221 and a closure top 218 that are the same or similar to the respective rod 21 and closure top 18 previously described herein. The receiver 210 is substantially similar to the receiver 10 with the exception of the orientation of spring tabs 260 that are otherwise substantially similar to the tabs 60 previously described herein with respect to the assembly 1. Similar to the previous discussion with respect to the assembly 1, the tabs 260 of the receiver 210, like the tabs 60 of the receiver 10, press against shallow grooves formed on an outside surface of the insert

214, keeping a saddle or curved surface of the insert 212 in a desired alignment to receive and ultimately frictionally engage the rod 221 along a substantial surface of the saddle. The insert may also have a flat outer surface instead of shallow grooves.

Because the illustrated assembly 201 only differs from the assembly 1 with respect to the tabs 260 of the receiver 210, only relevant portions of the receiver 210 will be described in greater detail here: The receiver 210 includes a base 240 integral with a pair of opposed upstanding arms 242 forming a cradle and defining a U-shaped channel 244 between the arms 242 with an upper opening 246 and a lower seat 248, the channel 244 having a width for receiving the rod 221, for operably receiving the rod 221 between the arms 242. Each of the arms 242 has an interior surface 250 that defines the inner cylindrical profile disposed about a central axis G and includes a partial helically wound guide and advancement structure 252. In the illustrated embodiment, the guide and advancement structure 252 is a partial helically wound interlocking flangeform configured to mate under rotation with a similar structure on the closure structure 218. However, it is foreseen that the guide and advancement structure 252 could alternatively be a square-shaped thread, a buttress thread, a reverse angle thread or other thread like or non-thread like helically wound discontinuous advancement structure for operably guiding under rotation and advancing the closure structure 218 downward between the arms 242, as well as eventual torquing when the closure structure 218 abuts against the rod 221.

An opposed pair of tool receiving and engaging apertures 254 are formed on outer surfaces 256 of the arms 242. A pair of substantially cylindrical inner surfaces 258 define the apertures 254, with a portion of each of the apertures 254 extending through the arms 242 as best illustrated in FIG. 12. With particular reference to FIGS. 11, 13 and 14, the pair of tabs 260, each having an upper end or body portion 262 integral with a respective arm 242 at an upper portion of one of the cylindrical surfaces 258, and a lower end 264 extending downwardly and eventually inwardly from the respective upper body portion 262 toward the central axis G of the receiver 210. As shown in FIG. 14, an operational orientation of each of the tabs 260 is angled toward the central axis G of the receiver with an inner surface 268 or edge 269 of the lower end 264 in sliding engagement with a slot 290 in the cooperating insert 214. As illustrated in FIGS. 11 and 13, the tabs 260 are typically initially disposed parallel to the central axis of the receiver 210. In the illustrated embodiment, the pressure insert 214, retainer 212 and bone screw shank 204 are first bottom loaded (or may be top loaded) into the receiver 210 in a manner as previously described herein with respect to the assembly 1 and then a tool (not shown) is inserted into each aperture 254 from the outside surface 256 and engages and pushes a surface 266 of the tab 260 and bends the tab 260 inwardly in a direction toward the receiver central axis G until the tab 260 is at the illustrated desired angular position. Such bending of the tabs 260 may also be performed prior to assembly of the receiver 210 with the insert 214, shank 204 and retainer 212. In such an arrangement, the insert 214 may be uploaded or downloaded into the receiver 210 with the saddle portion thereof in alignment with the tabs 260. After the insert 214 is in a desired axial position, the insert 214 is rotated about the axis G with the tabs 260 being manipulated to press against the surface 292. The insert 214 is rotated about the central axis G until the tabs 260 snap into the grooves or depressions 290 (or engage flat surfaces).

It is foreseen that in another embodiment according to the invention, the insert 214 is sized and shaped for top loading into the opening 246 of the receiver 210 and the tabs 260 are bent inwardly toward the axis G prior to assembly of the receiver 210 with the insert 214 and the other bone screw components. During assembly, after the insert 214 is lowered into the receiver 210 and moved past the guide and advancement structure 252, the outer surface 292 presses against the tabs 260, moving the tabs 260 outwardly and away from one another. Then, when the edges 269 of the tabs 260 come into contact with the surface of the grooves 290, the resilient tabs 260 snap into such grooves, maintaining alignment of the insert 214 and resisting any rotational movement of the insert 214 as the insert 214 is lowered into place over the upper portion 208 of the bone screw shank 204.

It is also foreseen that the tabs 260 may be machined or otherwise pre-fabricated to be angled or directed toward the receiver central axis G. As indicated above, the illustrated tabs 260 are resilient, having a spring-like nature. Thus, when operatively cooperating with the insert 214, the tabs 260 bias against the insert 214, holding such insert in a desired position. However, the tabs 260 are flexible enough to allow a user to make desired upward and downward adjustments of the position of the insert 214 within the receiver 210 with respect to the axis G.

With reference to FIGS. 15-21, a third embodiment of a bone screw assembly of the invention, generally 301 includes a shank 304 that further includes a body 306 integral with an upper portion or capture structure 308; a head or receiver 310; a retainer 312 illustrated as an open collar-like retaining and articulating structure; and a compression insert 314. The shank 304, the receiver 310 and the retainer 312 are substantially similar to the respective shank 4, receiver 10 and retainer 12 previously described herein with respect to the assembly 1. The receiver 310 is sized and proportioned slightly differently than the receiver 12 to cooperate with the insert 314. However, the receiver 310 otherwise includes the same component parts previously described herein with respect to the receiver 10. In particular, the receiver 310 includes a central axis H, a base 340, arms 342, a U-shaped channel 344, an interior surface with a guide and advancement structure 352, a pair of opposed apertures 354 upwardly and inwardly extending spring tabs 360, and an inner cavity 380 identical or substantially similar to the respective central axis B, base 40, arms 42, U-shaped channel 44, interior surface with a guide and advancement structure 52, apertures 54, upwardly and inwardly extending spring tabs 60 and inner cavity 80 of the receiver 10 of the assembly 1. The assembly 301 also cooperates with the rod 321 and a closure top 318 that are the same or similar to the respective rod 21 and closure top 18 previously described herein.

The compression or pressure insert 314 functions substantially similarly to the insert 14 previously described herein; however the insert 314 is of a different shape than the insert 14 and thus shall be described in detail herein.

The compression insert 314 is sized and shaped to be received by and uploaded into the receiver 310 at an opening into the cavity 380 at the base 340. In operation, the insert 314 is disposed between the rod 321 and the upper portion 308 of the bone screw shank 304. When the closure structure 318 presses upon the rod 321, the rod operatively presses upon the compression member 314 that in turn presses on the shank upper portion 308, but unlike the assemblies 1 and 101, the member 314 does not include a saddle. Therefore, rotational alignment of the rod 321 with the insert 314 is not

necessary. However, because of the compact cylindrical shape of the insert **314**, there is a possibility of the insert **314** becoming dislodged from a remainder of the assembly and undesirably moving up into the U-shaped channel **344** and out of the top of the receiver **310**. Therefore, the receiver **310** equipped with spring tabs **360** prohibit undesirable upward movement of the insert **314** out of the receiver **310**.

With particular reference to FIGS. **19-21**, the compression insert **314** has an operational central axis that is the same as the central axis **H** of the receiver **310**. The compression insert **314** has a central channel or through bore substantially defined by an inner cylindrical surface **386** and an inner partially spherical surface **388**. The insert through bore is sized and shaped to receive a driving tool (not shown) therethrough that engages a shank internal drive feature formed in the upper portion **308** when the shank is driven into bone. The surface **388** is sized and shaped to cooperate and mate with the spherical surface **330** of the shank upper portion **308** such that the surface **388** slidingly and pivotally mates with the spherical surface **330**. The surface **388** may include a roughening or surface finish to aid in frictional contact between the surface **388** and the surface **330**, once a desired angle of articulation of the shank **304** with respect to the retainer **312** and the receiver **310** is reached.

The compression insert **314** also includes a substantially planar top surface **390**, a bottom surface **392** and an outer cylindrical surface **394**. An outer angled surface or chamfer **395** is disposed between and connects the top surface **390** with the outer cylindrical surface **394**. The cylindrical surface **394** is sized to be received within the cavity **380** of the receiver **310** and slidingly mate with a cylindrical inner surface **398** partially defining the cavity **380**. The inner surface **398** is disposed directly below and adjacent to the spring tabs **360**. Thus, the compression insert **314** ultimately seats on the shank upper portion **308** and is disposed at least partially in the channel **344** such that the compression insert **314** top surface **390** substantially contacts the rod **321** when the rod is placed in the receiver **310** and the closure structure **318** is tightened therein. With particular reference to FIG. **17**, similar to the bottom surface **132** of the previously described insert **14**, the bottom surface **392** of the insert **314** is sloped or angled to provide clearance for pivoting movement of the shank upper portion **308** and the retainer **312**.

In operation, the tabs **360** may be bent inwardly toward the axis **H** before or after insertion of the insert **314** into the cavity **380**, either by top or bottom loading. Preferably, the tabs **360** are initially bent inwardly toward the axis **H**, followed by bottom loading of the insert **314** into the cavity **380** at the cavity opening at the base **340**. The shank **304** and the retainer **312** are then bottom loaded in a manner similar to what has been previously described herein with respect to the assembly **1**. As best illustrated in FIG. **18**, the tabs **360** engage the insert **314** at or near the chamfer **395**, prohibiting further upward movement of the insert **314** into a remainder of the cavity **380**. Eventually, the rod **321** and the closure top **318** are assembled with the receiver **310** in the manner described previously herein with respect to the receiver **10**, rod **21** and closure top **18**.

With reference to FIGS. **23** and **24**, in a fourth embodiment according to the invention, generally **401**, a receiver **410** is substantially identical to the receiver **310** of the assembly **301** with the exception that the spring tabs **360** are removed and replaced with a deformable material portion **460**. The assembly **401** otherwise includes a shank **404**, a retainer **412** and a compression insert **414** identical or substantially similar to the shank **304**, retainer **312** and compression insert **314** previously described herein with

respect to the assembly **301**. Formed on outside surfaces **456** of the receiver **410** are a pair of opposed apertures **457**. Each deformable portion or wall **460** partially defines the respective aperture **457**. A tool (not shown) is inserted into the aperture and is pressed against the deformable portion **460**, causing the portion **460** to extend into a cavity **480** of the receiver **410** in a direction towards a central axis **J**. Similar to the spring tabs **360**, the now deformed wall portions **460** abut against and prohibit upward movement of the insert **414** and thus desirably retain the insert **414** in the cavity **480**. If, as illustrated, the insert **414** is uploadable into the cavity **480** from an opening in the base **440** thereof, the portions **480** are preferably deformed prior to insertion of the insert **414** into the receiver **410**. It is foreseen that in downloaded embodiments, the portions **480** may be deformed after downloading of the insert **414** into the cavity **480**.

It is to be understood that while certain forms of the present invention have been illustrated and described herein, it is not to be limited to the specific forms or arrangement of parts described and shown.

What is claimed and desired to be secured by Letters Patent is as follows:

1. A polyaxial bone screw assembly comprising:

- a) a bone screw shank having an upper portion;
- b) a receiver having a cavity, the bone screw upper portion being receivable in the cavity;
- c) a retaining and articulating structure receivable in the cavity between the shank upper portion and the receiver, the retaining and articulating structure being unattached to both the shank and the receiver so as to be freely movable relative to both the shank and the receiver during positioning of the shank relative to the receiver;
- d) a compression insert disposed in the receiver during final positioning of the shank to lock the shank in place, the insert having a depression formed in an outer surface thereof and having a mating surface exclusively frictionally engageable with the bone screw upper portion, wherein the insert is spaced from the retaining and articulating structure; and
- e) resilient structure extending from the receiver and biasing against the compression insert at the depression thereof, the resilient structure resisting rotational movement of the compression insert within the receiver to maintain a desired alignment of the insert with the receiver, while allowing for upward and downward movement of the insert with respect to the receiver.

2. The assembly of claim **1** wherein the compression insert mating surface is concave and the bone screw upper portion is convex.

3. The assembly of claim **1** wherein the shank upper portion has a convex surface and the retaining and articulating structure has a concave surface in slidable mating engagement with the convex surface.

4. The assembly of claim **3** wherein the concave and convex surfaces are substantially spherical.

5. The assembly of claim **1** wherein the retaining and articulating structure has a convex surface and the receiver has a concave surface in slidable mating engagement with the convex surface.

6. The assembly of claim **5** wherein the concave and convex surfaces are substantially spherical.

7. The assembly of claim **1** wherein the shank upper portion has a tool engagement formation formed thereon adapted for non-slip engagement by a tool for driving the bone screw shank into bone.

17

8. The assembly of claim 7 wherein the tool engagement formation is a substantially hex shaped inner drive.

9. The assembly of claim 1 wherein the retaining and articulating structure is sized and shaped to be at least one of top-loadable and bottom-loadable into the receiver.

10. The assembly of claim 1 wherein the retaining and articulating structure further comprises first and second spaced ends, the retaining and articulating structure being compressible and [expandible] *expandable* with the first and second ends being movable toward and away from one another.

11. The assembly of claim 10 wherein the retaining and articulating structure has a central axis, the first and second ends each being substantially planar surfaces running substantially parallel to the axis.

12. The assembly of claim 10 wherein the retaining and articulating structure has a central axis, the first and second ends each being substantially planar surfaces running at an angle oblique to the axis.

13. The assembly of claim 1 wherein the bone screw shank is cannulated.

14. The assembly of claim 1 wherein

a) the bone screw shank has a body for fixation to bone, the shank body being integral with the shank upper portion; and

b) the assembly further comprising a closure structure insertable into the receiver, the closure structure for operably urging the insert into frictional engagement with the bone screw shank upper portion and moving the shank in a direction to frictionally lock the position of the retaining and articulating structure with respect to the shank upper portion and the receiver, thereby locking the shank body in a selected angle with respect to the receiver.

15. The assembly of claim 14 wherein:

(a) the receiver has upstanding spaced arms defining an open channel, the arms having guide and advancement structures on an inside surface thereof; and

(b) the closure structure is sized and shaped to be positionable between the arms for closing the channel, the closure structure having a closure guide and advancement structure for rotatably mating with the guide and advancement structures on the arms, biasing the closure structure upon advancement rotation against a longitudinal connecting member disposed in the channel.

16. The assembly of claim 1 wherein the resilient structure is a pair of opposed spring tabs attached to the receiver and extending toward a central axis of the receiver.

17. The assembly of claim 16 wherein the spring tabs are integral with the receiver.

18. The assembly of claim 16 wherein the spring tabs are directed upwardly toward a top opening of the receiver.

19. The assembly of claim 16 wherein the spring tabs are directed downwardly toward a base of the receiver.

20. The assembly of claim 1 wherein the insert depression is a shallow groove.

21. The assembly of claim 1 wherein the insert depression is a flat surface.

22. The assembly of claim 1 wherein the insert is one of top and bottom loaded.

23. In a polyaxial bone screw assembly for surgical implantation and including a shank and a threaded body for inserting into a bone and a receiver having a channel for receiving a longitudinal connecting member within the channel, the improvement wherein:

18

a) the shank has a first curvate surface at an upper end thereof and is pivotally engaged with an interior surface of the receiver; and further comprising:

b) an articulation structure located between the shank upper end and the receiver, the articulation structure having a second curvate surface and an opposed third curvate surface, the articulation structure being in slidable engagement with receiver at the second curvate surface, the articulation structure third curvate surface being in slidable engagement with the shank upper end first curvate surface, the articulation structure being freely movable relative to both the shank and the receiver during positioning of the shank relative to the receiver;

c) a compression insert having a fourth curvate surface in slidable engagement with the shank first curvate surface, the insert being spaced from the articulating structure, and the insert having a depression formed in an outer surface thereof; and

d) resilient structure extending from the receiver and biasing against the compression insert at the depression thereof, the resilient structure resisting rotational movement of the compression insert within the receiver to maintain a desired alignment of the insert with the receiver, while allowing for upward and downward movement of the insert with respect to the receiver.

24. The improvement of claim 23 wherein the shank upper end has a tool engagement formation formed thereon adapted for non-slip engagement by a tool for driving the bone screw shank into bone.

25. The improvement of claim 23 wherein the articulation structure is sized and shaped to be at least one of top-loadable and bottom-loadable into the receiver.

26. The improvement of claim 23 wherein the articulation structure further comprises first and second spaced ends, the articulation structure being compressible and [expandible] *expandable* with the first and second ends being movable toward and away from one another.

27. The improvement of claim 23 wherein the resilient structure is a pair of opposed spring tabs integral with the receiver and extending toward a central axis of the receiver.

28. The improvement of claim 27 wherein the opposed spring tabs face downwardly.

29. The improvement of claim 27 wherein the opposed spring tabs face upwardly.

30. In a bone screw assembly having a receiver pivotally connected to a bone screw shank, the receiver having an opening for receiving a longitudinal connecting member and a compression insert disposed in the receiver for frictional engagement with the longitudinal connection member and having a depression formed in an outer surface thereof, the improvement comprising:

a) resilient structure extending from the receiver and biasing against the compression insert at the depression thereof, the resilient structure resisting rotational movement of the compression insert within the receiver to maintain a desired alignment of the insert with the receiver, while allowing for upward and downward movement of the insert with respect to the receiver; and

b) an articulation structure disposed between the bone screw shank and the receiver, the articulation structure having a first curvate wall in sliding engagement with the receiver and a second curvate wall in sliding engagement with the bone screw shank.

31. The improvement of claim 30 wherein the resilient structure is a pair of opposed spring tabs attached to the receiver and extending toward a central axis of the receiver.

19

32. The improvement of claim 31 wherein the opposed spring tabs face downwardly.

33. The improvement of claim 31 wherein the opposed spring tabs face upwardly.

34. The improvement of claim 30 wherein the insert depression is a shallow groove.

35. The improvement of claim 30 wherein the insert depression is a flat surface.

36. The improvement of claim 30 wherein the articulation structure further comprises first and second spaced ends, the articulation structure being compressible and [expandable] *expandable* with the first and second ends being movable toward and away from one another.

37. The improvement of claim 30 wherein the articulation structure is freely movable relative to both the shank and the receiver during positioning of the shank relative to the receiver.

[38. In a bone screw assembly having a receiver pivotally connected to a bone screw shank, the shank having a lower portion attachable to a bone and an upper head portion, the receiver having an opening for receiving a longitudinal connecting member, the assembly also having a compression insert disposed in the receiver for frictional engagement with the longitudinal connecting member and the shank upper head portion, the improvement wherein the receiver comprises:

a resilient structure integral with the receiver, the structure having a surface projecting inwardly and facing downwardly into the receiver in a direction towards the shank; the structure biasing against the compression insert, holding the insert within the receiver and downwardly against the shank upper head portion, and resisting rotational movement of the insert to maintain a desired alignment of the insert with the receiver, while allowing for upward and downward movement of the insert with respect to the receiver.]

[39. The improvement of claim 38 wherein the resilient structure is a first resilient structure; and further comprising a second resilient structure integral with the receiver and located opposite the first resilient structure, the second resilient structure also projecting inwardly and facing downwardly into the receiver in a direction towards the shank.]

[40. In a bone screw assembly having a receiver pivotally connected to a bone screw shank, the shank having a lower portion attachable to a bone and an upper head portion, the receiver having an opening for receiving a longitudinal connecting member, the assembly also having a compression insert disposed in the receiver for frictional engagement with the longitudinal connecting member and the shank upper head portion, the improvement wherein the receiver comprises:

a resilient structure integral with the receiver, the structure having a surface projecting inwardly and facing upwardly into the receiver in a direction towards the shank; the structure biasing against the compression insert, holding the insert within the receiver and downwardly against the shank upper head portion, and resisting rotational movement of the insert to maintain a desired alignment of the insert with the receiver, while allowing for upward and downward movement of the insert with respect to the receiver.]

[41. The improvement of claim 40, wherein the resilient structure is a first resilient structure; and further comprising a second resilient structure integral with the receiver and located opposite the first resilient structure, the second resilient structure also projecting inwardly and facing upwardly into the receiver in a direction towards the shank.]

20

42. In a bone screw assembly having a receiver pivotally connected to a bone screw shank, the receiver having an opening for receiving a longitudinal connecting member and a compression insert disposed in the receiver for frictional engagement with the longitudinal connection member, the improvement comprising:

- a) resilient structure extending from the receiver and biasing against the compression insert at a depression formed in a surface of the insert, the resilient structure resisting rotational movement of the compression insert within the receiver to maintain a desired alignment of the insert with the receiver, while allowing for upward and downward movement of the insert with respect to the receiver; and
- b) an articulation structure disposed between the bone screw shank and the receiver, the articulation structure having a first curvate wall in sliding engagement with the receiver and a second curvate wall in sliding engagement with the bone screw shank; and
- c) the compression insert comprising a top and bottom portion having a bottom surface and a through-bore with an opening on the bottom surface sized and shaped to mate with an upper portion of the bone screw shank.

43. The improvement of claim 42, wherein the top portion of the through-bore is cylindrical shaped, and the bottom portion of the through-bore is sized and shaped to mate with the upper portion of the bone screw shank.

44. A polyaxial bone screw assembly comprising:

- a) a bone screw shank having an upper portion with a top surface;
- b) a receiver having an internal cavity with an integral spherical seating surface adjacent a lower opening, the bone screw upper portion receivable in the cavity through the opening;
- c) a retaining and articulating structure receivable in the cavity and positioned below the top surface of the shank and between the shank upper portion and the receiver, the retaining and articulating structure having an outer spherical surface for seating against the receiver seating surface and being unattached to both the shank and the receiver so as to be freely movable relative to both the shank and the receiver during positioning of the shank relative to the receiver;
- d) a compression insert disposed in the receiver during final positioning of the shank to lock the shank in place, the insert having a lower first mating surface frictionally engageable with the bone screw upper portion and an upper second mating surface to engage a rod; and
- e) resilient structure extending from the receiver and biasing against the compression insert at a depression formed in a surface of the insert, the resilient structure resisting rotational movement of the compression insert within the receiver to maintain a desired alignment of the insert with the receiver, while allowing for upward and downward movement of the insert with respect to the receiver.

45. *The polyaxial bone screw assembly of claim 44, wherein the receiver internal cavity further comprises an expansion portion above the spherical seating surface, the expansion portion being configured to allow the retaining and articulating structure to expand therein around the shank upper portion during loading of the bone screw shank through the lower opening, and to then snap around the shank upper portion with an inner spherical surface of the retaining and articulating structure in sliding cooperation with an outer spherical surface of the shank upper portion.*

21

46. The polyaxial bone screw assembly of claim 45, further comprising an outer groove formed into the outer spherical surface of the retaining and articulating structure to provide additional clearance for the expansion of the retaining and articulating structure within the expansion portion of the receiver internal cavity.

47. The assembly of claim 1, wherein the receiver cavity further comprises an expansion portion above a spherical seating surface, the expansion portion being configured to allow the retaining and articulating structure to expand therein around the shank upper portion during loading of the bone screw shank into the receiver, and to then snap around the shank upper portion with an inner spherical surface of the retaining and articulating structure in sliding cooperation with an outer spherical surface of the shank upper portion.

48. The assembly of claim 47, further comprising an outer groove formed into the outer spherical surface of the retain-

22

ing and articulating structure to provide additional clearance for the expansion of the retaining and articulating structure within the expansion portion of the receiver cavity.

49. The improvement of claim 23, wherein the receiver further comprises an expansion portion above the receiver interior surface, the expansion portion being configured to allow the articulation structure to expand therein around the shank upper end during loading of the shank into the receiver and to then snap around the shank upper end with the articulation structure third curvate surface entering into slidable engagement with the shank upper end first curvate surface.

50. The improvement of claim 49, further comprising an outer groove formed into the articulation structure second curvate surface to provide additional clearance for the expansion of the articulation structure within the receiver expansion portion.

* * * * *