



(19) **United States**

(12) **Patent Application Publication**

Mori et al.

(10) **Pub. No.: US 2003/0040696 A1**

(43) **Pub. Date: Feb. 27, 2003**

(54) **APPARATUS AND METHOD FOR IN VIVO DELIVERY OF THERAPEUTIC AGENTS**

(75) Inventors: **Kenji Mori**, San Diego, CA (US); **Iwao Nozawa**, Carlsbad, CA (US); **Shuji Sato**, Kashiwa (JP)

Correspondence Address:  
**FISH & RICHARDSON, PC**  
**4350 LA JOLLA VILLAGE DRIVE**  
**SUITE 500**  
**SAN DIEGO, CA 92122 (US)**

(73) Assignee: **Hisamitsu Pharmaceutical Company, Inc.**

(21) Appl. No.: **10/274,626**

(22) Filed: **Oct. 18, 2002**

**Related U.S. Application Data**

(60) Division of application No. 09/186,564, filed on Nov. 4, 1998, now Pat. No. 6,490,482, which is a continuation-in-part of application No. 08/964,872, filed on Nov. 5, 1997.

(30) **Foreign Application Priority Data**

Apr. 27, 1998 (JP)..... 9144/0852

**Publication Classification**

(51) **Int. Cl.<sup>7</sup>** ..... **A61N 1/30**  
(52) **U.S. Cl.** ..... **604/20**

(57) **ABSTRACT**

Electroporation electrodes are laminated to a permeable membrane to form an electrode membrane. Such an electrode membrane is useful for a continuous controlled delivery of a therapeutic agent through the skin or mucosa, when placed in direct contact with the skin or mucosa and by application of electric field pulses at specified intervals. An electrode membrane can be assembled such that it incorporates an iontophoretic electrode in the same device. This device can be jointly utilized for electroporation and iontophoretic drug delivery through the skin and mucosal membrane.

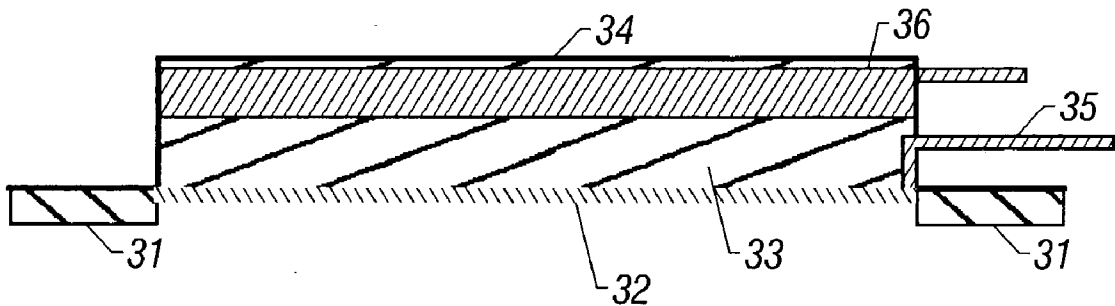

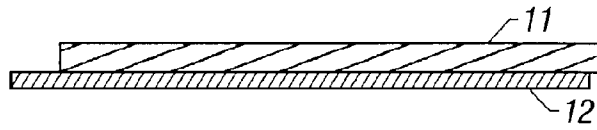

FIG. 1

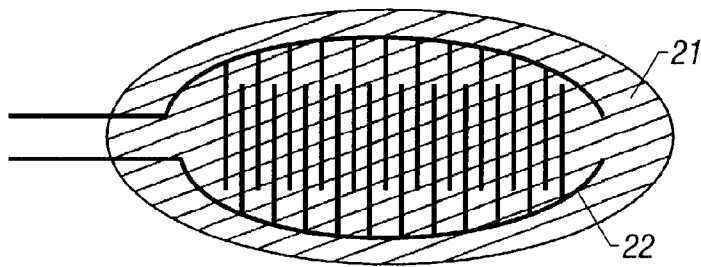

FIG. 2

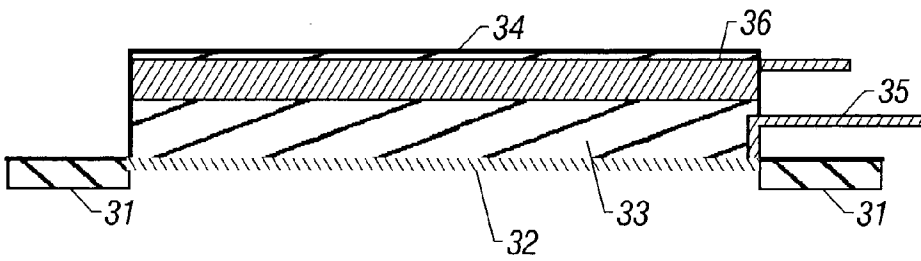

FIG. 3

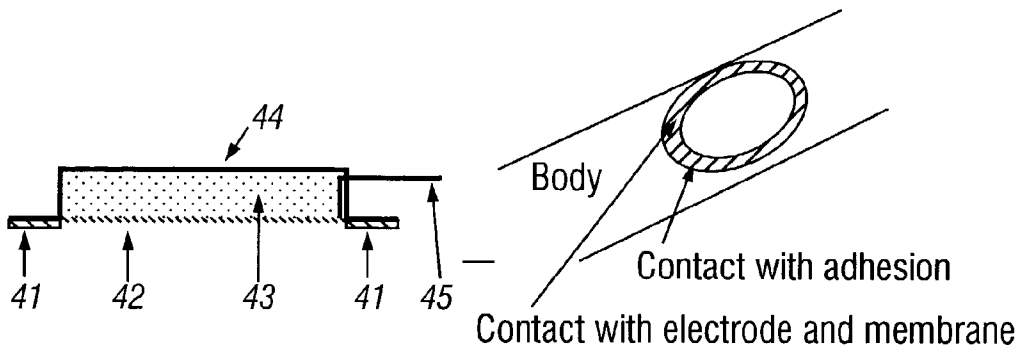

FIG. 4A

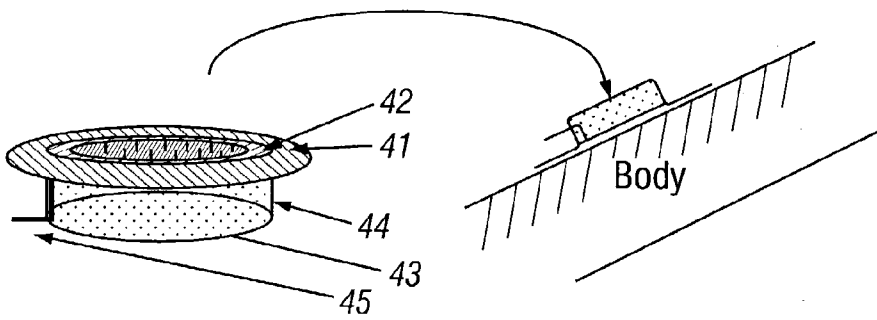

FIG. 4B

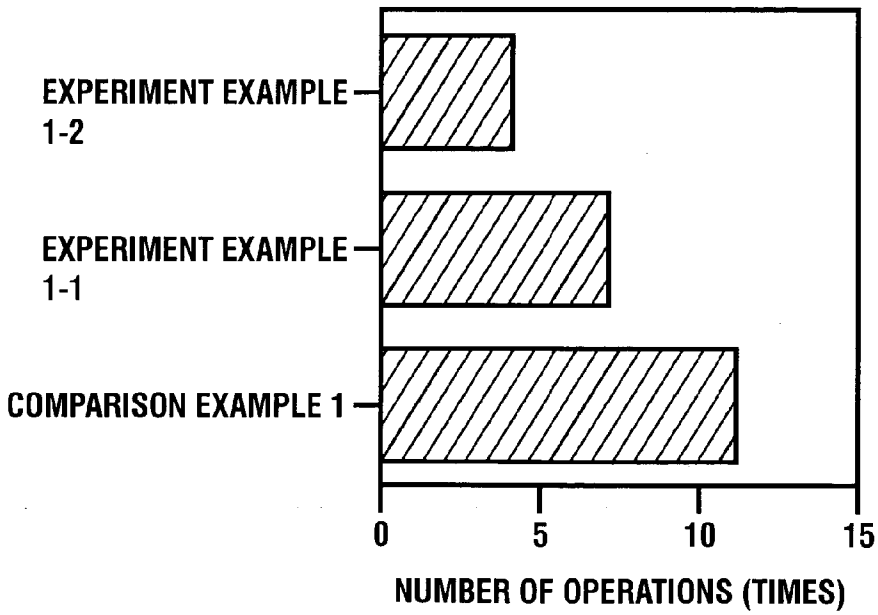

FIG. 5

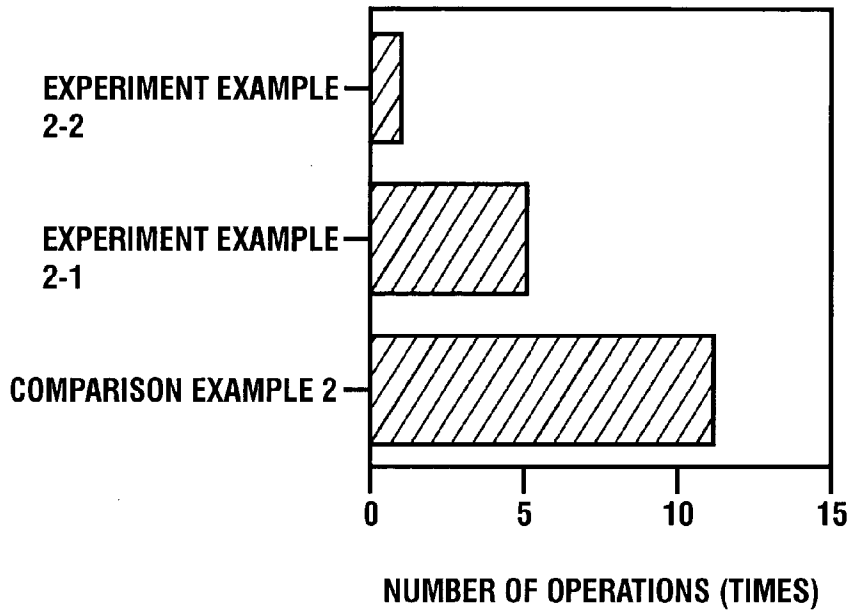

FIG. 6

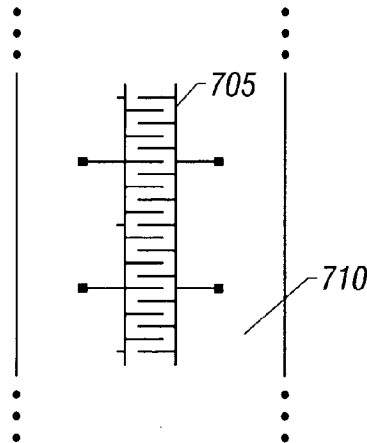
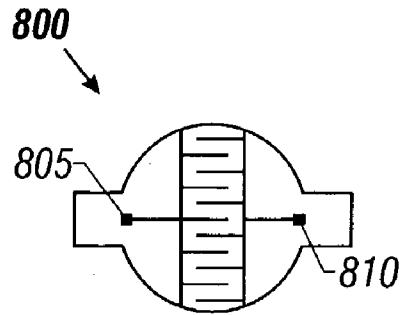
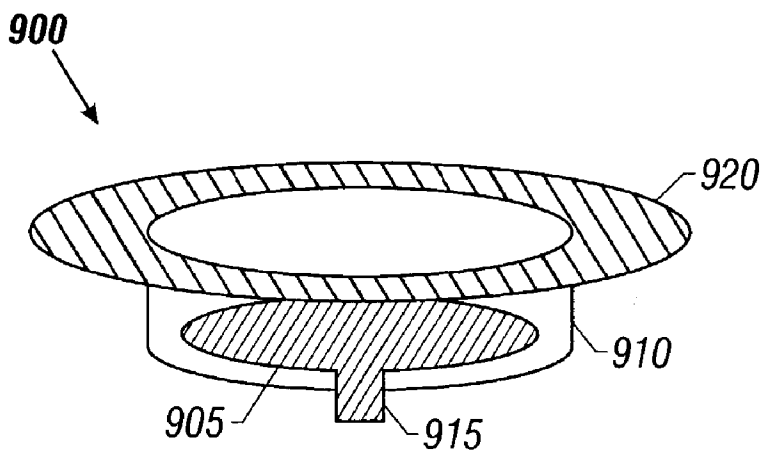

FIG. 7



**FIG. 8**



**FIG. 9**

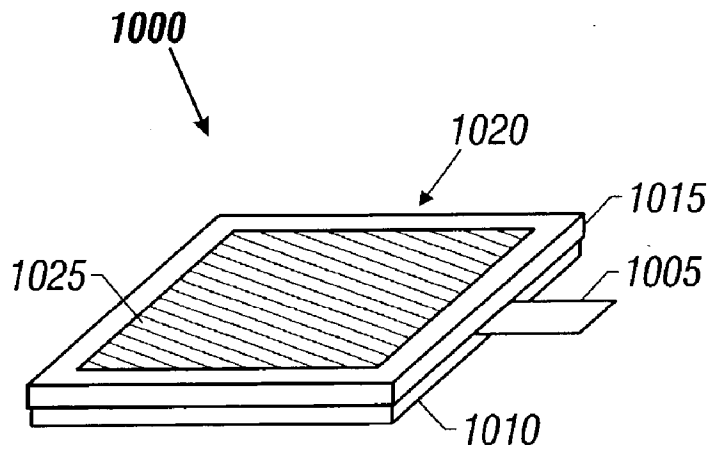

**FIG. 10A**

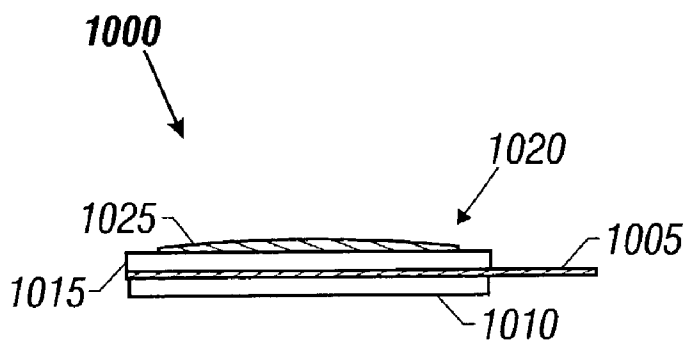

**FIG. 10B**

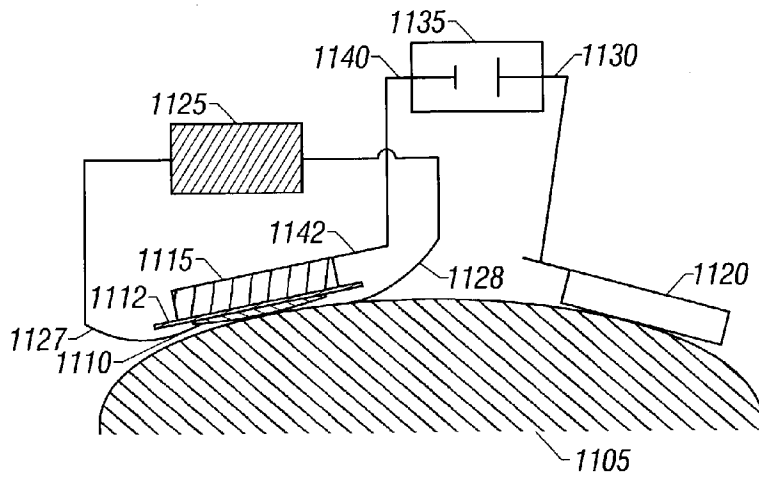

FIG. 11

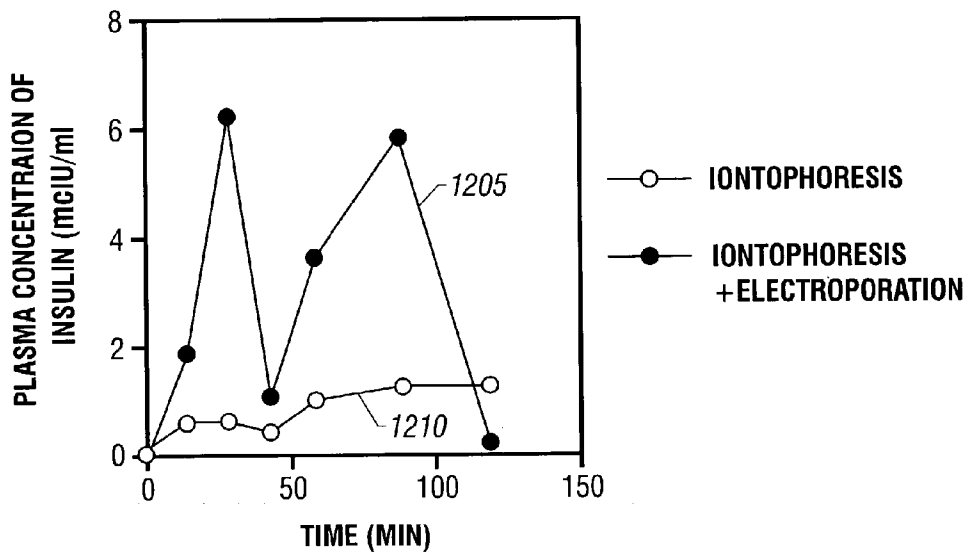

FIG. 12

## APPARATUS AND METHOD FOR IN VIVO DELIVERY OF THERAPEUTIC AGENTS

[0001] This is a continuation-in-part of U.S. application Ser. No. 08/964,872, filed Nov. 5, 1997 (pending).

### TECHNICAL FIELD

[0002] The invention relates to delivery of therapeutic agents, and more particularly to a method and apparatus for in vivo delivery of therapeutic agents through the skin or mucosa using an electromotive force such as electroporation or iontophoresis.

### BACKGROUND INFORMATION

[0003] Electroporation, which includes electropermealization, involves the creation of aqueous pathways in lipid bilayer membranes by the application of a brief electric field pulse. Electroporation has found wide-spread application in molecular biology and in transgenics as a method of introducing DNA or other material to a cell by momentarily charging the cell with a high voltage. In recent years, this technique has also been applied to the delivery of therapeutic agents through skin or mucosa. A pore or opening is created in the skin or mucosa by an electric field created by the positive and negative differential between two electrodes. This reversible path or route (pore) created using electroporation increases the membrane (skin, mucosa) penetration of a substance. However, there have been problems in placing electrodes and establishing the proper relationship between the position of the electrodes.

[0004] In addition, multiple administrations have required multiple applications of electrodes and therapeutic agents, entailing repeated affixing and removing of electrodes, thereby irritating the site tissue. Similarly, delivery of therapeutic agents over a long period of time or multiple applications of voltage have required multiple alternating applications of electrodes and therapeutic agents. In constructing an actual device, difficulties have arisen in containing the therapeutic agents on the surface of the electrodes and in placing the surface containing therapeutic agents and the surface of the electrodes in direct contact with the skin. Thus, conventional devices which use electroporation have unresolved problems.

[0005] It is known that it is possible to further increase the permeation of therapeutic agents using electroporation and iontophoresis jointly. Iontophoresis uses electrical current to activate and to modulate the diffusion of a charged molecule across a biological membrane, such as the skin, in a manner similar to passive diffusion under a concentration gradient, but at a facilitated rate. In general, iontophoresis technology uses an electrical potential or current across a semipermeable barrier using an iontophoretic electrode pair, an iontophoretic electrode (anode or cathode) and a counter electrode. To jointly use electroporation and iontophoresis, an iontophoretic electrode must be placed in the same compartment (in the same device) as an electroporation electrode pair. While there are examples of in vitro experiments using electroporation and iontophoresis jointly, conventional techniques have not been able to create a device which can practically jointly use both types of electrodes.

[0006] Accordingly the inventor has determined that it would be desirable to have a method or device which would provide the following capabilities not provided by conventional techniques:

[0007] (1) simple administration of therapeutic agents using an electroporation electrode pair via skin or mucosa;

[0008] (2) application of electrodes for long periods of time and application of voltage multiple times without requiring multiple applications and removals of electrodes;

[0009] (3) simultaneous application of electric field pulses for electroporation and a pharmaceutical composition containing a therapeutic agent; and

[0010] (4) joint utilization of electroporation and iontophoretic electrodes.

[0011] The present invention provides such capabilities.

### SUMMARY

[0012] A permeable membrane which is porous and is used to support electrodes for electroporation is useful for substantially continuous controlled delivery of a therapeutic agent through the skin or mucosa, when placed in direct contact with the skin or mucosa and by application of electric field pulses at specified intervals. The electroporation electrodes can be affixed to this porous membrane to form an electrode membrane. In addition, an electrode membrane can be assembled such that it can incorporate an iontophoretic electrode in the same device. This device can be jointly utilized for electroporation and iontophoresis. In addition, a device which has this kind of electrode membrane is practically useful and easily manufactured.

### DESCRIPTION OF DRAWINGS

[0013] FIG. 1 shows a side view of a device according to a first embodiment of the invention.

[0014] FIG. 2 shows a planar view of a device according to a first embodiment of the invention.

[0015] FIG. 3 shows a third embodiment of the invention which can jointly use electroporation and iontophoresis.

[0016] FIG. 4 shows a second embodiment of the invention.

[0017] FIG. 5 is a chart showing a comparison of numbers of operations from three different applications of electroporation (Experiment Example 1-2, Experiment Example 1-1, Comparison 1).

[0018] FIG. 6 is a chart showing a comparison of numbers of operations from applications of joint uses of electroporation and iontophoresis (Experiment Example 2-2, Experiment Example 2-1, Comparison 2).

[0019] FIG. 7 shows a membrane strip according to the invention.

[0020] FIG. 8 shows an electrode membrane according to the invention.

[0021] FIG. 9 shows a pharmaceutical device or "donor device" for administering a therapeutic agent.

[0022] FIGS. 10A and 10B are perspective and side views, respectively, of an iontophoretic reference electrode.

[0023] FIG. 11 illustrates an in vivo percutaneous absorption experiment to measure the absorption of insulin.



[0024] FIG. 12 shows the concentration of insulin in the plasma obtained from a rat versus time.

[0025] Like reference numbers and designations in the various Drawings indicate like elements.

#### DETAILED DESCRIPTION

[0026] The structure and operational parameters of preferred embodiments of the invention will be explained below making references to the Drawings. FIGS. 1 and 2 show a device according to one embodiment of the invention. FIG. 1 is a side view of the device. FIG. 2 is a planar view of the same device shown in FIG. 1. An agent permeable membrane 11, 21 (in FIGS. 1 and 2, respectively) is preferably a porous membrane. A contact electrode pair for electroporation 12, 22 is affixed to the agent permeable membrane 11, 21, such that the device of the first embodiment forms an electrode membrane. The contact electrode pair 12, 22 is shown with two comb-like electrodes in an interdigitated pattern (though the electrodes do not contact one another), but the invention is not limited to that form. A portion of the contact electrode pair 12, 22 is shown as protruding from the membrane 11, 21. However, the contact electrode pair 12, 22 can also be entirely embedded in the agent permeable membrane. This protruding portion of the contact electrode pair is a terminal for connecting the contact electrode pair 12, 22 to a power supply device (not shown).

[0027] The materials used to construct the membrane 11, 21 supporting the contact electrode pair 12, 22 are not particularly limited, but can be selected (e.g., heuristically) as desirable depending upon the type of therapeutic agent to be administered or the nature of the pharmaceutical composition containing a therapeutic agent. For example, when a watersoluble pharmaceutical composition or therapeutic agent is used, a hydrophilic membrane which does not have limited membrane permeability for that pharmaceutical composition is selected. If a lipid-soluble pharmaceutical composition or therapeutic agent is used, it would be desirable to use a hydrophobic membrane which does not have limited membrane permeability for that pharmaceutical composition. Similarly, it is desirable to use a porous membrane having pores which do not hamper the delivery of a therapeutic agent or pharmaceutical compositions being administered. A pore size of about 0.01  $\mu\text{m}$  to 10  $\mu\text{m}$  is preferred, and about 0.1 to 5  $\mu\text{m}$  is more preferred in order to retain the pharmaceutical composition in the device, prevent leakage, and maintain a desirable drug permeation rate through the membrane. For example, the materials used for the membrane in various embodiments include, but are not limited to, porous or foam substances such as nylon, polyvinylidene fluoride, cellulose, nitro cellulose, polycarbonate, polysulfone, polyethylene, polypropylene, non-woven fabric, gauze, woven fabric, paper, cotton, polyethylene foam, polypropylene foam, polyvinyl acetate foam, polyurethane foam, polyamide foam, and polyurethane foam. These materials and chemical modifications and treatments thereof are provided as examples but the materials covered by the invention are not limited to these.

[0028] Examples of methods of affixation for the contact electrode pair 12, 22 and the above-described supporting membrane 11, 21 include, but are not limited to, adhesion, printing, vapor deposition, and plating. Of these methods,

printing is especially desirable because it can be easily controlled by techniques such as using a pattern or screen printing a form. Adhesion is also desirable as a simple method of integration.

[0029] The contact electrode pair 12, 22 is a pair of anode and cathode electrodes which are affixed on the permeable membrane 11, 21. It is desirable to have the distance between the two electrodes small in order to generate high voltage efficiency. However, there is the possibility of short circuits in the membrane 11, 21. Considering factors such as efficiency in applying electric pulses, simplicity of affixation, and accuracy of affixation, the distance will vary depending upon the affixation method used. In general, about 10  $\mu\text{m}$  to 1 cm is preferable, about 50  $\mu\text{m}$  to 5  $\mu\text{m}$  is more preferred, and about 100  $\mu\text{m}$  to 2  $\mu\text{m}$  is yet more preferred.

[0030] The contact electrode pair 12, 22 is made from materials which are or can be made electrically conductive such as carbon, platinum, gold, titanium, aluminum, nickel, steel, silver, silver chloride, copper, copper chloride, or an alloy of one of these. Carbon, silver, and silver chloride are preferred because of their advantages for printing.

[0031] In use, the electrode membrane of the first embodiment is applied to a site of administration, preferably the skin or mucosa. A therapeutic agent is then applied to the, agent permeable membrane. The porous nature of the agent permeable membrane brings the therapeutic agent into contact with the skin. An electric signal is applied utilizing electroporation such that the therapeutic agent is delivered through the skin. Alternately, the therapeutic agent could be pre-impregnated into the agent permeable membrane prior to application to the site of administration.

[0032] A second embodiment of the invention, as shown in FIG. 4, is a device for electroporation integrating the above-described electrode membrane. An adhesion layer 41 includes an adhesive for keeping the device in contact with skin or mucosa. An electrode membrane for electroporation 42, as described above and shown in FIGS. 1 and 2, is on a lower portion of the device. A pharmaceutical composition layer 43 contains a therapeutic agent to be administered. A casing 44 forms a reservoir which contains the pharmaceutical composition layer 43. A contact electrode terminal 45 for connecting a contact electrode pair (within the electrode membrane 42; see the contact electrode pair 12, 22 in FIGS. 1 and 2) to a power supply device (not shown) protrudes from the casing 44.

[0033] In use, a device according to the second embodiment is applied to a site of administration, held in place by the adhesive. The reservoir may already contain the pharmaceutical composition or the pharmaceutical composition may be added after application. Similar to the first embodiment, the pharmaceutical composition or therapeutic agent come into contact with the site of administration by permeating the agent permeable membrane. The therapeutic agent is delivered by applying an electric signal to the contact electrodes utilizing electroporation.

[0034] A third embodiment of the invention, as shown in FIG. 3, is a device which can jointly use electroporation and iontophoresis. An adhesion layer 31 includes an adhesive for keeping the device in contact with skin or mucosa. An electrode membrane for electroporation 32, as described

above and shown in **FIGS. 1 and 2**, is on a lower portion of the device. A pharmaceutical composition layer **33** contains a therapeutic agent to be administered. A casing **34** forms a reservoir which contains the pharmaceutical composition layer **33**. A contact electrode terminal **35** for connecting a contact electrode pair (within **32**; the contact electrode pair **12, 22** in **FIGS. 1 and 2**) to a power supply device (not shown) protrudes from the casing **34**. The above components are similar to those of the second embodiment shown in **FIG. 4**. However, the third embodiment also has an iontophoretic electrode (anode or cathode) **36** for iontophoresis located between the electrode membrane **32** and the casing **34**. A counter electrode (not shown) which is opposite to the iontophoretic electrode (i.e., if the iontophoretic electrode **36** is an anode, the counter electrode is a cathode) is also attached to the skin or mucosa to complete an electrical circuit for iontophoresis.

**[0035]** In use, a device according to the third embodiment is applied to a site of administration, held in place by the adhesive. The reservoir may already contain the pharmaceutical composition or the pharmaceutical composition may be added after application. Similar to the first embodiment, the pharmaceutical composition or therapeutic agent come into contact with the site of administration by permeating the agent permeable membrane. The therapeutic agent is delivered by applying an electric signal to the contact electrodes and another electric signal to the iontophoretic electrode thus utilizing electroporation and iontophoresis jointly.

**[0036]** The casing **34, 44** (in **FIGS. 3 and 4**, respectively) is preferably made from materials such that the casing **34, 44** is elastically deformable (i.e., flexible yet shape-retentive) and water-resistant. For example, polymers such as polyvinylidene chloride, polyvinyl chloride, polyurethane, polyester, polystyrene, poly acryl, polyamide, polyoxymethylene, polyphenylenesulfuramide, polyamide, polyimide, polyacrylonitrile, polyetherketon polyethersulfone, polysulfone, etherimide, polybutadiene, and isoprene or copolymers of these materials may be used, though the invention is not limited to them. The casing preferably is made from the above materials which are in a film form (e.g., a backing film) or have been manufactured into a shape. The thickness is not especially limited, but a thickness of about 5 to 250  $\mu\text{m}$  provides desirable shape-retention and flexibility.

**[0037]** The administered pharmaceutical composition delivered by the device includes any composition which would have a desired biological effect. The composition is contained in the pharmaceutical composition layer **33, 43** and preferably includes but is not limited to, in addition to a base component (such as a therapeutic agent), electrolytes, absorption accelerants, stabilizers, pH buffers, thickeners, detergents, emulsifiers, ion exchange resins, ion exchange membranes, or nonwoven fabrics.

**[0038]** The casing **35, 45** and electrode membrane **32, 42** are preferably sealed using a process such as heat sealing.

**[0039]** When an iontophoretic electrode **36** (anode or cathode) is integrated, the iontophoretic electrode **36** may be a polarized electrode made from materials such as carbon, platinum, gold, or titanium or an unpolarized electrode, but an unpolarized electrode is more preferred. An unpolarized anode electrode preferably includes silver or copper, but silver is more preferred. An unpolarized cathode electrode

preferably includes silver chloride or copper chloride, but silver chloride is more preferred.

**[0040]** For electroporation, an electric signal is applied to the contact electrode pair such that a voltage differential is created preferably ranging from about 10 to 2000 V/cm. About 50 to 1000 V/cm is more preferred and about 50 to 500 V/cm is yet more preferred. A recommended pattern of applying the electric signal is one such as exponential logarithmic wave forms or square wave forms, but is not limited to those. The electric signal for electroporation is preferably applied one or more times.

**[0041]** For iontophoresis, an electric signal is applied to the iontophoretic electrode pair (the iontophoretic electrode **36** of **FIG. 3** and the counter electrode), preferably as a pulsed current signal from about 0.01 to 10 mA, and more preferably about 0.01 to 5 mA. A voltage differential is created preferably from about 0.1 to 50 V, more preferably about 1 to 30 V, and yet more preferably about 3 to 15 V. The pulsed current signal has a pulse frequency of pulse depolarization preferably about 100 Hz to 1000 KHz, more preferably about 1 to 500 KHz, and yet more preferably about 10 to 300 KHz. The pulsed current signal has a duty cycle with an ON/OFF ratio preferably about 1 to 99%, more preferably about 10 to 80%, and yet more preferably about 15 to 50%. Waveforms for applying electric current, direct current, pulse, and pulse depolarization, can be freely set.

**[0042]** As described above, the pharmaceutical composition preferably includes a therapeutic agent (such as a biologically active substance) to achieve the desired therapeutic effect upon delivery (e.g., to ameliorate some disorder). The therapeutic agents used in the present invention are not restricted in type. Examples include, but are not limited to: analgesics such as morphine, fentanyl, pethidine, codeine, buprenorphine, butorphanol, etazocine, or pentazocine; peptides/proteins such as insulin, calcitonin, calcitonin gene-related peptide, vasopressin, desmopressin, prorelin (TRH), adrenocorticotrophic hormone (ACTH), luteinizing hormone releasing hormone (LH-RH), growth hormone releasing hormone (GRH), nerve growth factor (NGF) or other releasing factors, angiotensin, parathyroid hormone (PTH), thyroid-stimulating hormone (TSH, thyrotropin), follicle stimulating hormone (FSH), luteinizing hormone (LH), prolactin, serum gonadotrophin, human chorionic gonadotrophin (HCG), human menopausal gonadotrophin (HMG), human growth hormone, somatostatin, somatomedin, glucagon, oxytocin, gastrin, secretin, endorphin, enkephalin, endothelin, cholecystokinin, neurotensin, interferon, interleukin, transferrin, erythropoietin (EPO), superoxide dismutase (SOD), granulocyte colony stimulating factor (G-CSF), vasoactive intestinal peptide (VIP), muramyl dipeptide, urogastrone, or human atrial natriuretic peptide (h-ANP); tranquilizers such as carbamazepine, chlorpromazine, diazepam, or nitrazepam; antineoplastic drugs such as bleomycin, doxorubicin, 5-fluorouracil, or mitomycin cardiotonics such as digitalis, digoxin, or digitoxin; sex hormones such as estradiol or testosterone; or hypotensive drugs such as reserpine or clonidine. Furthermore, antisense DNA and oligonucleotides such as triple helix-forming oligonucleotide can also be used.

**[0043]** Using the techniques described above, the present invention effectively delivers a therapeutic agent via the skin or mucosa. In conventional electroporation electrodes, typi-

cally an electrode pair was attached to a film which was not permeable to substances. Medicinal solution was applied to a site such as skin. The electrode film was then placed over the site and electric field pulses applied. In cases where multiple administrations were necessary, the procedure had to be repeated. It could not be done in one application. When jointly using iontophoresis, after applying medicinal solution to an administration site, the site was covered by an electrode film. After electroporation was performed, the electrode film was removed. An electrode for iontophoresis was then applied to the site and an electric current for iontophoresis was applied. It was necessary to perform each step of this operation. When electroporation was again to be applied, the process was repeated. The process could not be completed in one physical application of electrodes.

[0044] The present invention not only permits only one application of a device including an electrode membrane to administer a therapeutic agent, but also continuous administration has been made possible. Even when jointly using iontophoresis, only a single affixation of a device integrating an electrode membrane (for electroporation) and an electrode for iontophoresis is necessary. Furthermore, when affixing the electrodes, electroporation and iontophoresis are not limited to a single application. Accordingly, by using a device according to the present invention as described above, a device is provided which enables electroporation alone or electroporation in conjunction with iontophoresis and can be used for multiple applications over extended periods of time. The present invention can be used broadly throughout the medical field in the administration of therapeutic agents.

[0045] Examples of implementations of the present invention are given below to illustrate the use and efficacy of the present invention, but the present invention is not limited to the forms described below.

[0046] In Experiment Example 1, ease of administration is compared when sodium benzoate is administered using a prior art electrode pair, using an electrode membrane of the present invention, and using a device created using an electrode membrane of the present invention. Compliance was compared using the number of operations as an indicator.

[0047] In Experiment Example 1-1, an electrode membrane of the present invention was used. An electrode membrane was created by laminating a silver electrode pair on a Durapore SVLP™ membrane (made by Millipore™; pore diameter=3.0 μm) (the same configuration as shown in FIGS. 1 and 2). Adhesive was applied to the outer circumference thereon, and the electrode membrane was affixed to the skin. Medicine (an aqueous solution of sodium benzoate, 100 mg/ml) on the electrode membrane was administered at 200 μl every hour for three hours (a total of 600 μl). Each time the medicinal solution was administered an electric field pulse of 200 V/cm was applied from an electroporation power supply device (made by BTX™). The number of operations was counted.

[0048] In Experiment Example 1-2, a device including an electrode membrane of the present invention was used. A device as shown in FIG. 4 was created using an electrode membrane as described in Experiment Example 1-1. 600 μl of medicinal solution were contained within the device. The device containing this electrode membrane was affixed to

the skin and every hour an electric field pulse of 200 V/cm was applied from an electroporation power supply device (made by BTX™). The number of operations was counted.

[0049] In Comparison Example 1, a prior art electrode film was used. A presently marketed electrode film was used (BT454-2P™ by BTX™). A medicinal solution (an aqueous solution of sodium benzoate, 100 mg/ml) was applied to the skin and then that area was covered by the electrode film. An electric field pulse of 200 V/cm was applied from an electroporation power supply (made by BTX™). These operations were repeated three times, and the number of operations was counted.

[0050] The results of Experiment Example 1 are shown in FIG. 5. Using an electrode membrane of the present invention (Experiment Example 1-1) required a total of seven operations: (1) affixing the electrodes; (2) applying the medicinal solution; (3) applying voltage; then after waiting one hour, (4) applying the medicinal solution; (5) applying voltage; then after waiting one hour, (6) applying the medicinal solution; and (7) applying voltage.

[0051] Applying a device including an electrode membrane of the present invention (Experiment Example 1-2) required a total of four operations: (1) affixing the device; (2) applying voltage; then after waiting one hour, (3) applying voltage; and then after waiting one hour, (4) applying voltage.

[0052] Using a prior art electrode film and administering it using conventional methods (Comparison Example 1) required a total of eleven operations: (1) applying the medicinal solution; (2) affixing the electrodes; (3) applying voltage; then after waiting one hour, (4) peeling off the electrodes; (5) applying the medicinal solution; (6) affixing the electrodes; (7) applying voltage; then after waiting one hour, (8) peeling off the electrodes; (9) applying the medicinal solution; (10) affixing the electrodes; and (11) applying voltage.

[0053] As shown by the number of operations above, administration becomes simpler using an electrode membrane of the present invention. When practical application is considered, when patients administer therapeutic agents at home, the administration form of Comparison Example 1 is not practical. On the other hand, patients can easily perform the administration at home using a device such as the one in Experiment Example 1-2.

[0054] In Experiment Example 2, ease of administration is compared when electroporation and iontophoresis are jointly used in administering lidocaine hydrochloride using an electrode membrane of the present invention and using a conventional electrode film. Compliance was compared using the number of operations as an indicator.

[0055] In Experiment Example 2-1, 200 μl of an aqueous solution of lidocaine hydrochloride (5%) were added to a device including a presently marketed electrode for iontophoresis (tansQ™ by Iomed™). The device was created by integrating the iontophoretic electrode and the electrode membrane created in Experiment Example 1-1 according to the present invention as shown in FIG. 3. This device, as well as a counter electrode (tansQ™ by Iomed™) were applied to the skin. The electrode pair for iontophoresis (the positive electrode is on the medicinal side at the site of administration, the negative electrode is the counter elec-

trode) was connected to an iontophoresis power supply device. The electroporation electrode pair was connected to an electroporation power supply device. 200 V/cm was applied from the electroporation power supply device, and then 0.1 mA/cm<sup>2</sup> was applied from the iontophoresis power supply device for one hour. After one hour, 200 V/cm was again applied from the electroporation power supply device, and then 0.1 mA/cm<sup>2</sup> was again applied from the iontophoresis power supply device for one hour under the same conditions. The number of operations was counted.

[0056] In Experiment Example 2-2, a similar operation as in Experiment Example 2-1 was performed. However, initially the start and stop times for application of electric signals for iontophoresis and electroporation application times were set in a timer and so were performed automatically. The number of operations was counted.

[0057] In Comparison Example 2, 200  $\mu$ l of an aqueous solution of lidocaine hydrochloride (5%) were added to a presently marketed device including an electrode for iontophoresis (tansQ™ by Iomed™). Upon the skin, electroporation was applied using a conventional electrode pair (at 200 V/cm). The iontophoresis device containing lidocaine was applied to the skin and electric current was applied for one hour. After one hour, electroporation was applied, and then once again iontophoresis was applied for one hour. The number of operations was counted.

[0058] The results of Experiment Example 2 are shown in FIG. 6. Experiment Example 2-1 required a total of five operations: (1) affixing the device; (2) applying electroporation voltage; (3) applying iontophoresis electrical current; (4) applying electroporation voltage; and (5) applying iontophoresis electrical current.

[0059] In Experiment Example 2-2, because the application of electroporation voltage and iontophoresis electrical current of Experiment Example 2-1 was able to be performed automatically using a timer, the number of operations was reduced leaving only a single operation to perform (affixing the device).

[0060] By contrast, Comparison Example 2 required a total of eleven operations: (1) affixing the electrode film; (2) applying electroporation voltage; (3) removing the electroporation electrodes; (4) affixing the iontophoresis device containing lidocaine; (5) applying iontophoresis electrical current; (6) removing the iontophoresis device containing lidocaine; (7) affixing the electrode film; (8) applying electroporation voltage; (9) removing the electroporation electrodes; (10) affixing the iontophoresis device containing lidocaine; (11) applying iontophoresis electrical current.

[0061] The efficacy of promoting absorption of therapeutic agents through the skin and mucosa using electroporation has been discussed above. In Experiment Example 3, the effect of electroporation on insulin absorption using an electrode membrane in accordance with the present invention with insulin has been studied and is described below.

[0062] To prepare an electroporation electrode, carbon ink 705 was imprinted into a porous membrane 710 of polyvinylidene fluoride (such as, Milipore: Hydrophilic Durapore, Pore size 5.0 microns) forming a membrane strip 700, as shown in FIG. 7. Before conducting the experiment, a portion of the resulting membrane strip was cut in the form of an electrode membrane 800, as shown in FIG. 8, with a

positive electrode connection 805 and a negative electrode connection 810 protruding from either side.

[0063] FIG. 9 shows a pharmaceutical device or "donor device" for administering a therapeutic agent. To prepare the donor device, an electrode cup 900 was formed by adding a silver/silver chloride electrode 905 to a cup 910, as shown in FIG. 9. A terminal 915 of the electrode 905 protrudes from the side of the cup 910 to provide a connection for an iontophoretic generator (not shown). The cup 910 has a rim 920 to support an attached membrane, as described below. Agar powder was suspended in water. This suspension was heated approximately to 70° C. in order to melt the agar and form an aqueous solution of 1.5% agar. The solution was poured into the electrode cup 900 and the agar solution was hardened at room temperature. This electrode cup including the agar gel is the donor device.

[0064] FIGS. 10A and 10B are perspective and side views, respectively, of an iontophoretic reference electrode 1000. To prepare the iontophoretic reference electrode 1000, a silver electrode 1005 was placed on a polyethylene terephthalate film 1010. A layer of polyurethane 1015 was used to delineate the edge of the silver electrode 1005, forming a compartment 1020 on the electrode. The walls of the compartment 1020 form a depression for containing a liquid. A previously prepared aqueous solution 1025 of 12% polyvinyl alcohol and including sodium chloride was poured into the compartment 1020. The solution 1025 was hardened into a gel at -80° C.

[0065] An appropriate dosage of insulin was estimated by weight in a silicon coated tube. Phosphoric acid, acetic acid, and boric acid (each at a concentration of approximately 1/25M) were combined. This mixture was added to the insulin. The mixture was vortexed for a few seconds to dissolve the insulin. An aqueous solution of 4% bovine serum albumin and an aqueous solution of 28% urea were added to the mixture. An aqueous solution of sodium hydroxide (approximately 2M) was added to the mixture to adjust the pH to approximately 7.0. The final concentration of insulin in this solution was approximately 500 IU/ml (where 1 mg is about 28 IU). This solution is referred to as a "donor solution".

[0066] FIG. 11 illustrates an in vivo percutaneous absorption experiment to measure the absorption of insulin. The abdomen of an SD rat 1105 (7 weeks old) was shaved. The electrode membrane 1110 was attached along the rim 1112 of the donor device 1115, contacting the agar gel in the electrode cup. Approximately 40  $\mu$ l of the donor solution including insulin was placed on the opposite side of the electrode membrane 1110 from the agar gel. The electrode membrane 1110 and attached donor device 1115 were placed on the rat 1105 such that the donor solution on the electrode membrane 1110 was in direct contact with the shaved portion of the rat 1105. The iontophoretic reference electrode 1120 was also placed on another part of the shaved portion of the rat 1105. Cords from an electroporation pulse generator 1125 were clamped to the positive and negative electrode connections 1127, 1128, respectively, of the electrode membrane 1110. The reference electrode 1120 was connected to a positive terminal 1130 of an iontophoretic generator 1135. A negative terminal 1140 of the iontophoretic generator 1135 was connected to the silver/silver chloride electrode terminal 1142 of the donor device 1115.

[0067] Immediately after starting the experiment, approximately 200 V from the electroporation generator **1125** were applied for 10 msec./pulse for about 15 minutes (approximately 693 pulses). Approximately 0.4 mA of direct current was simultaneously applied from the iontophoretic generator **1135**. Thus, both iontophoresis and electroporation were applied for this first 15 minutes. Thereafter, only iontophoretic application continued for an additional period of approximately 45 minutes. Over the course of time, blood was drawn from the jugular vein of the rat **1105**. After Heparin processing, the plasma was analyzed with an ELISA kit, a DSL Human Insulin kit for measuring human insulin.

[0068] In Comparative Example 3, a similar process is followed as in Experiment Example 3, but in Comparative Example 3 only iontophoresis was used. The preparation of the donor device, the iontophoresis reference electrode, the donor solution, and the plasma analysis was similar to that of Experiment Example 3.

[0069] In Comparative Example 3, the measurement of absorption was similar to that of Experiment Example 3. The configuration of components is similar to that shown in FIG. **11**, although Comparison Example 3 did not use electroporation and so did not include an electrode membrane, electroporation generator, or electrical connections for electroporation.

[0070] The abdomen of an SD rat (7 weeks old) was shaved. A porous membrane was attached along the rim of the donor device, contacting the agar gel in the electrode cup. Approximately 40  $\mu$ l of the donor solution including insulin was placed on the opposite side of the porous membrane from the agar gel. The porous membrane and attached donor device was placed on the rat such that the donor solution on the porous membrane was in direct contact with the shaved portion of the rat. The iontophoretic reference electrode was also placed on another part of the shaved portion of the rat. The reference electrode was connected to a positive terminal of an iontophoretic generator. A negative terminal of the iontophoretic generator was connected to the silver/silver chloride electrode terminal of the donor device. Approximately 0.4 mA of direct current was applied from the iontophoretic generator. Iontophoretic application continued for a period of approximately 60 minutes. Over the course of time, blood was drawn from the jugular vein of the rat. After Heparin processing, the plasma was analyzed with an ELISA kit, a DSL Human Insulin kit for measuring human insulin.

[0071] FIG. **12** shows the concentration of insulin in the plasma obtained from the rat versus time, from both Experiment Example 3 and Comparison Example 3. Curve **1205** shows the concentration resulting from the application of iontophoresis and electroporation according to the present invention. Curve **1210** shows the concentration resulting from applying iontophoresis alone. This chart shows that by using iontophoresis and electroporation as described in Experiment Example 3, the amount of insulin absorbed was approximately 811 micro-IU/ml-minute, shown by the area under curve **1205** for 0 to 120 minutes. In contrast, the amount of insulin absorbed using the technique described in Comparison Example 3 (where the electrode membrane of the present invention is not used) was approximately 208 micro-IU/ml-minute, about one-fourth of the results of Experiment Example 3.

[0072] In making these calculations, before placing the membrane and donor device on the rat, the background concentration of insulin in the rat's plasma was first measured. The concentration for each time point was determined by subtracting this background concentration from the measured concentration for that time point.

[0073] These examples clearly show that an electrode membrane utilizing both electroporation and iontophoresis according to the present invention to administer therapeutic agents such as insulin is effective. In addition, the improvement in administration by using both electroporation and iontophoresis shows that this technique and device can be more effective than using iontophoresis alone. The results Of Experiment Example 3 and Comparison Example 3 clearly show that the permeable electrode membrane device including both electroporation and iontophoretic electrodes is more effective in delivering therapeutic agents, such as insulin, than iontophoresis alone.

[0074] As described above, the device of the present invention integrates both the electrode membrane for electroporation and the electrode for iontophoresis into a single device, making it possible to have a device which jointly uses electroporation and iontophoresis. Previously existing technology relating to combined application of electroporation and iontophoresis typically required multiple applications, such as by applying an electroporation electrode, removing the electrode, and then applying an iontophoretic electrode to the same site. This process was not generally practical. Using the present invention, it is not necessary to remove the electroporation electrodes from the site of application each time a therapeutic agent is administered. With one application of an electrode membrane, multiple administrations of therapeutic agents and continuous administration of therapeutic agents over long periods of time are possible. Thus, the present invention provides simultaneous application of iontophoresis and electroporation from a single device without multiple applications.

[0075] A number of embodiments of the present invention have been described. Nevertheless, it will be understood that various modifications may be made without departing from the spirit and scope of the invention. Accordingly, other embodiments are within scope of the following claims.

What is claimed is:

1. A device for administering a therapeutic agent, including an agent permeable membrane having a pair of contact electrodes, such that when the device is contacted to a site of administration, the agent permeable membrane directly contacts the site of administration.
2. The device of claim 1 where the agent permeable membrane has pores with a diameter from about 0.01  $\mu$ m to 10  $\mu$ m.
3. The device of claim 2 where the agent permeable membrane has pores with a diameter from about 0.1  $\mu$ m to 5  $\mu$ m.
4. The device of claim 1 where the agent permeable membrane is made from one or more materials which have a permeability matched to permeation characteristics of the therapeutic agent.
5. The device of claim 1 where the agent permeable membrane is selected from the group consisting of: nylon, polyvinylidene fluoride, cellulose, nitro cellulose, polycarbonate, polysulfone, polyethylene, polypropylene, non-

woven fabric, gauze, woven fabric, paper, cotton, polyethylene foam, polypropylene foam, polyvinyl acetate foam, polyurethane foam, polyamide foam, and polyurethane foam.

6. The device of claim 1 where the contact electrodes are from about 10  $\mu\text{m}$  to 1 cm apart.

7. The device of claim 6 where the contact electrodes are from about 50  $\mu\text{m}$  to 5 mm apart.

8. The device of claim 7 where the contact electrodes are from about 100  $\mu\text{m}$  to 2 mm apart.

9. The device of claim 1 where the contact electrodes are made from a metal or a semiconductor.

10. The device of claim 1 where the contact electrodes are made from carbon, silver, or silver chloride.

11. The device of claim 1 which further includes a casing attached to the agent permeable membrane.

12. The device of claim 11 where the casing is attached to the agent permeable membrane such that a reservoir is formed between the casing and the agent permeable membrane.

13. The device of claim 12 which is adapted for application to skin or mucosa.

14. The device of claim 12 where the casing is made from a material that is elastically deformable.

15. The device of claim 12 where the casing is made from a material that is water-resistant.

16. The device of claim 12 where the casing is made from a polymer or copolymer.

17. The device of claim 12 where the casing is made from at least one material selected from the group consisting of: polyvinylidene chloride, polyvinyl chloride, polyurethane, polyester, polystyrene, polyacryl, polyamide, polyoxymethylene, polyphenylenesulfonamide, polyamide, polyimide, polyacrylonitrile, polyetherketone, polyethersulfone, polysulfone, etherimide, polybutadiene, and isoprene.

18. The device of claim 12 where the casing is from about 5 to 250  $\mu\text{m}$  thick.

19. The device of claim 12 which further includes a pharmaceutical composition having a therapeutic agent where the pharmaceutical composition is contained in the reservoir.

20. The device of claim 19 where the pharmaceutical composition further includes one or more substances selected from the group consisting of: an electrolyte, an absorption accelerant, a stabilizer, a pH buffer, a thickener, a detergent, an emulsifier, an ion exchange resin, an ion exchange membrane, or a nonwoven fabric.

21. The device of claim 12 where the reservoir includes an iontophoretic electrode.

22. The device of claim 21 where the iontophoretic electrode is a polarized electrode made from a material selected from the group consisting of: carbon, platinum, gold, or titanium.

23. The device of claim 21 where the iontophoretic electrode is an unpolarized electrode.

24. The device of claim 23 where the iontophoretic electrode is an anode electrode which includes copper.

25. The device of claim 23 where the iontophoretic electrode is an anode electrode which includes silver.

26. The device of claim 23 where the iontophoretic electrode is a cathode electrode which includes copper chloride.

27. The device of claim 23 where the iontophoretic electrode is a cathode electrode which includes silver chloride.

28. The device of claim 1 where the therapeutic agent is one or more agents selected from the group consisting of: an analgesic, a peptide/protein, a tranquilizer, an antineoplastic drug, a cardiotonic, a hormone, a hypotensive drug, and a polynucleotide.

29. The device of claim 1 which further includes an adhesion layer upon the agent permeable membrane which contacts the site of administration.

30. The device of claim 12 where the casing is sealed to the agent permeable membrane using heat sealing.

31. An electrode membrane device including:

(a) an adhesive layer,

(b) an agent permeable membrane attached to the adhesive layer,

(c) a first electrode affixed to the agent permeable membrane,

(d) a therapeutic agent,

(e) a pharmaceutical composition including one or more non-biologically active substances and the therapeutic agent,

(f) a casing which forms a reservoir between the agent permeable membrane and the casing where the reservoir contains the pharmaceutical composition, and

(g) a second electrode affixed to the casing.

32. A method of in vivo administration of a therapeutic agent including the following steps:

(a) contacting a device which includes an agent permeable membrane having a pair of contact electrodes to a site of administration, such that the agent permeable membrane directly contacts the site of administration,

(b) applying a therapeutic agent to the agent permeable membrane, and

(c) applying an electric signal to the contact electrodes.

33. The method of claim 32 where the contact electrodes are for electroporation.

34. The method of claim 33 where the electric signal creates a voltage differential from about 10 to 2000 V/cm between the contact electrodes.

35. The method of claim 34 where the voltage differential is from about 50 to 1000 V/cm.

36. The method of claim 35 where the voltage differential is from about 50 to 500 V/cm.

37. The method of claim 33 where the electric signal is applied in a square wave form to the contact electrodes.

38. The method of claim 33 where the electric signal is applied in an exponential logarithmic wave form to the contact electrodes.

39. A method of in vivo administration of a therapeutic agent including the following steps:

(a) contacting a device which includes an agent permeable membrane having a pair of contact electrodes to a site of administration such that the agent permeable membrane directly contacts the site of administration, a casing attached to the agent permeable membrane forming a reservoir, a pharmaceutical composition including the therapeutic agent where the pharmaceutical composition is contained in the reservoir, an iontophoretic electrode which is located in the reservoir;

(b) contacting a counter electrode to a second site;  
(c) applying a first electric signal to the contact electrodes;  
and

(d) applying a second electric signal to the iontophoretic electrode.

**40.** The method of claim 39 where the second electric signal is a pulsed current signal from about 0.01 to 10 mA.

**41.** The method of claim 40 where the pulsed current signal is from about 0.01 to 5 mA.

**42.** The method of claim 39 where the second electric signal creates a voltage differential from about 0.1 to 50 V between the iontophoretic electrode and the counter electrode.

**43.** The method of claim 42 where the voltage differential is from about 1 to 30 V.

**44.** The method of claim 43 where the voltage differential is from about 3 to 15 V.

**45.** The method of claim 39 where the second electric signal is a pulse depolarization signal at a pulse frequency from about 100 Hz to 1000 KHz.

**46.** The method of claim 45 where the pulse frequency is from about 1 to 500 KHz.

**47.** The method of claim 46 where the pulse frequency is from about 10 KHz to 300 KHz.

**48.** The method of claim 39 where the second electric signal has a duty cycle with an ON/OFF ratio between about 1 and 99%.

**49.** The method of claim 48 where the duty cycle is between about 10 and 80%.

**50.** The method of claim 49 where the duty cycle is between about 15 and 50%.

**51.** The device of claim 19 where the therapeutic agent is one or more agents selected from the group consisting of: an analgesic, a peptide/protein, a tranquilizer, an antineoplastic drug, a cardiogenic, a hormone, a hypotensive drug, and a polynucleotide.

**52.** The device of claim 12 which further includes an adhesion layer upon the agent permeable membrane which contacts the site of administration.

**53.** A device for administering a therapeutic agent, comprising:

an electrode cup, including an electrode and a rim; and

an electrode membrane attached to the rim of the electrode cup, including a permeable membrane and a pair of electrodes imprinted into the permeable membrane.

**54.** The device of claim 53 where the electrode in the electrode cup is connected to an iontophoretic generator.

**55.** The device of claim 53 where the electrodes in the electrode membrane are connected to an electroporation generator.

\* \* \* \* \*