



US00D396308S

United States Patent [19]
Hägglund

[11] **Patent Number:** **Des. 396,308**

[45] **Date of Patent:** ****Jul. 21, 1998**

[54] **RAIL COMPONENT**

[76] **Inventor:** **Ruben Hägglund**, Lilla Hanåsa, S-579
92 Högsby, Sweden

[**] **Term:** **14 Years**

[21] **Appl. No.:** **38,331**

[22] **Filed:** **May 3, 1995**

[30] **Foreign Application Priority Data**

Nov. 10, 1994 [SE] Sweden 94-2302

[51] **LOC (6) Cl.** **25-01**

[52] **U.S. Cl.** **D25/164**

[58] **Field of Search** D25/38, 41-44,
D25/119-124, 164; 52/730.3, 730.4, 730.5,
731.2, 731.3, 732.1, 732.2; 256/59, 65

[56] **References Cited**

U.S. PATENT DOCUMENTS

D. 9,891	4/1877	Starr, Jr.	D25/122
D. 27,394	7/1897	Horton	D25/121
D. 336,345	6/1993	Fasth et al.	D25/122
D. 361,139	8/1995	Nomura	D25/122
1,129,040	2/1915	McLure	D25/120
3,686,810	8/1972	Allen	52/731.2

FOREIGN PATENT DOCUMENTS

2372376	6/1978	France	52/730.4
524199	9/1957	Italy	52/732.1

Primary Examiner—Doris Clark
Attorney, Agent, or Firm—Laff, Whitesel, Conte & Saret,
Ltd.

[57] **CLAIM**

The ornamental design for a rail component, as shown and described.

DESCRIPTION

FIG. 1 is a perspective view of a rail component;
FIG. 2 is an elevational view of one end of the rail component of FIG. 1;
FIG. 3 is an elevational view of an opposite end of the rail component of FIG. 1;
FIG. 4 is an elevational view of one side of the rail component of FIG. 1;
FIG. 5 is an elevational view of the other side of the rail component of FIG. 1;
FIG. 6 is a top plan view of the rail component of FIG. 1; and
FIG. 7 is a bottom plan view of the rail component of FIG. 1.

1 Claim, 3 Drawing Sheets

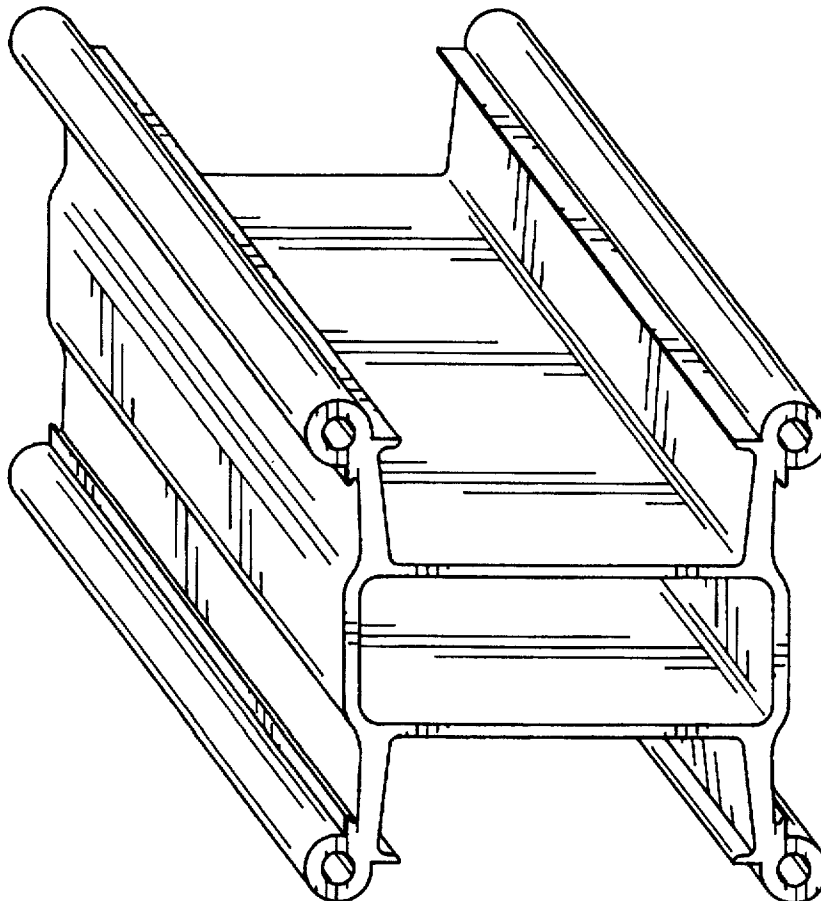

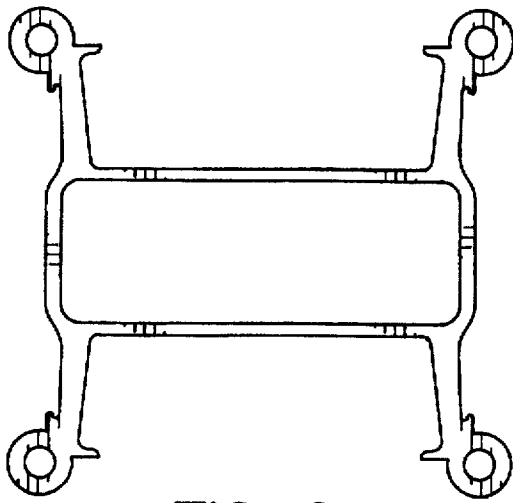

FIG. 2

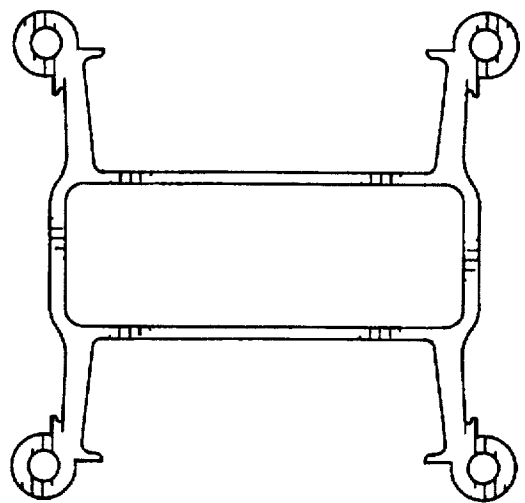

FIG. 3

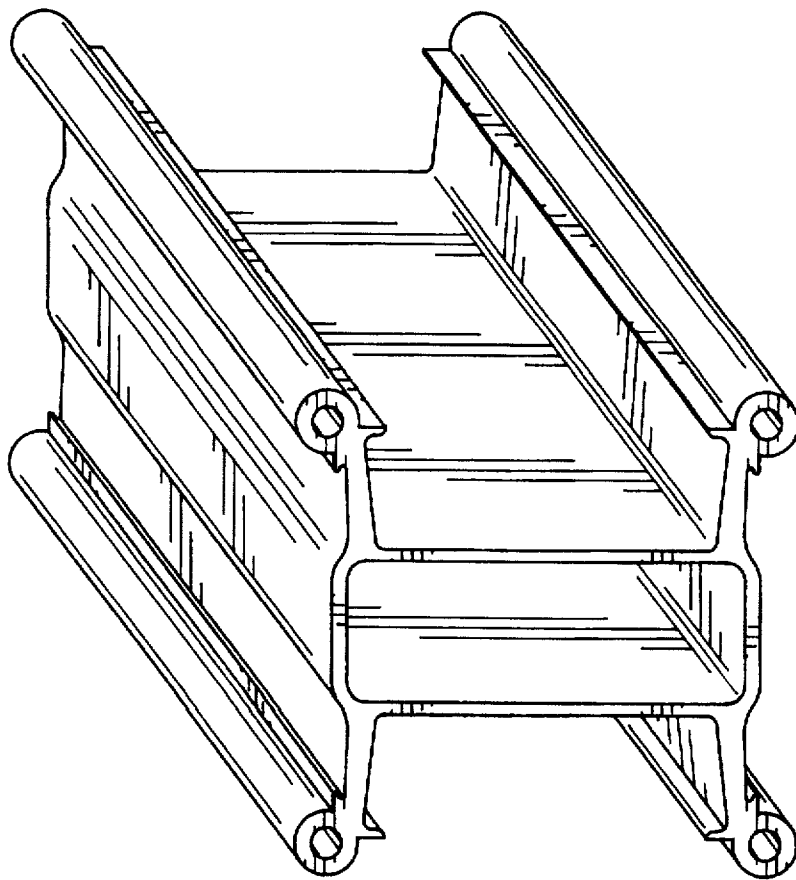

FIG. 1

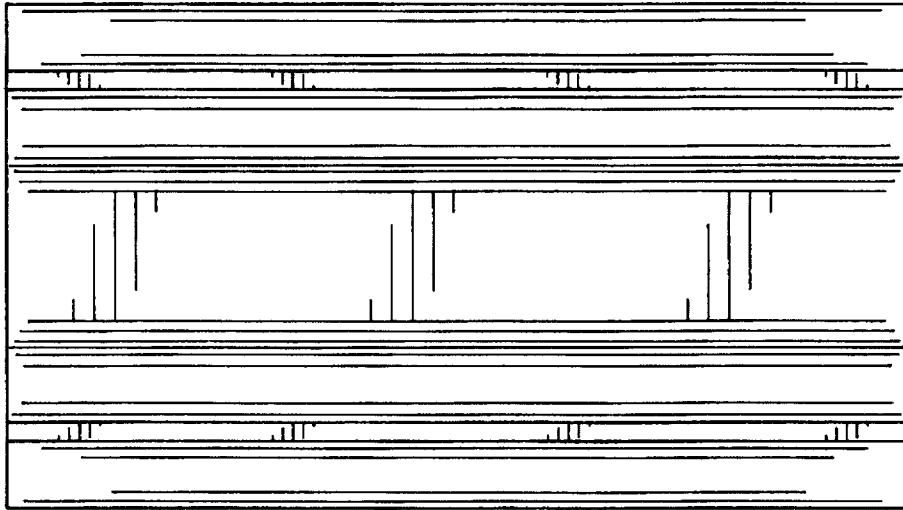

FIG. 4

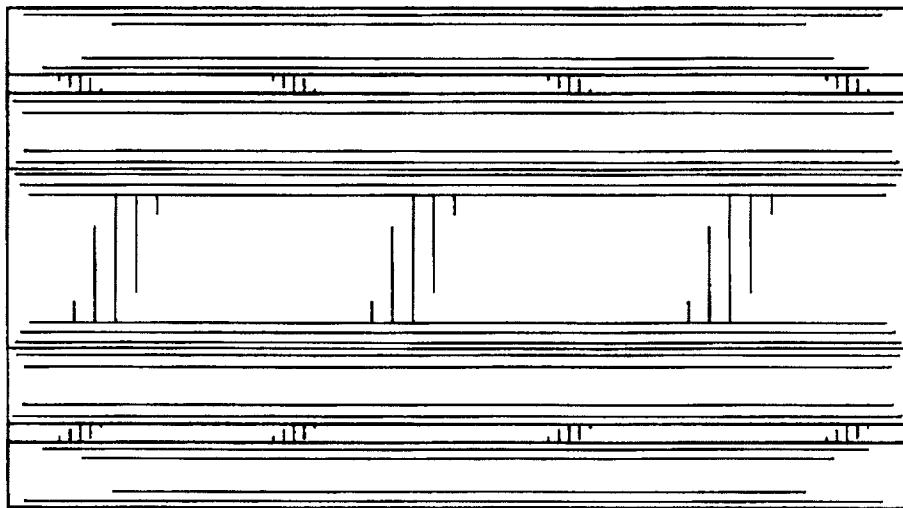

FIG. 5

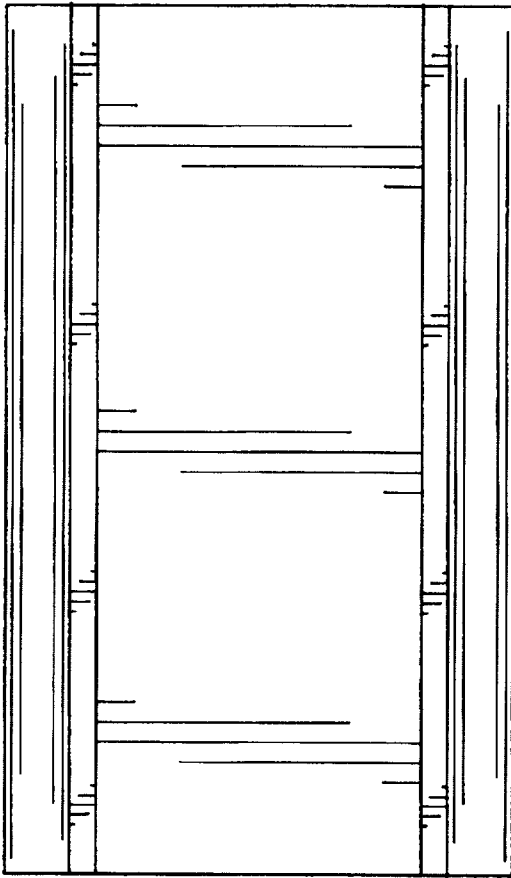

FIG. 6

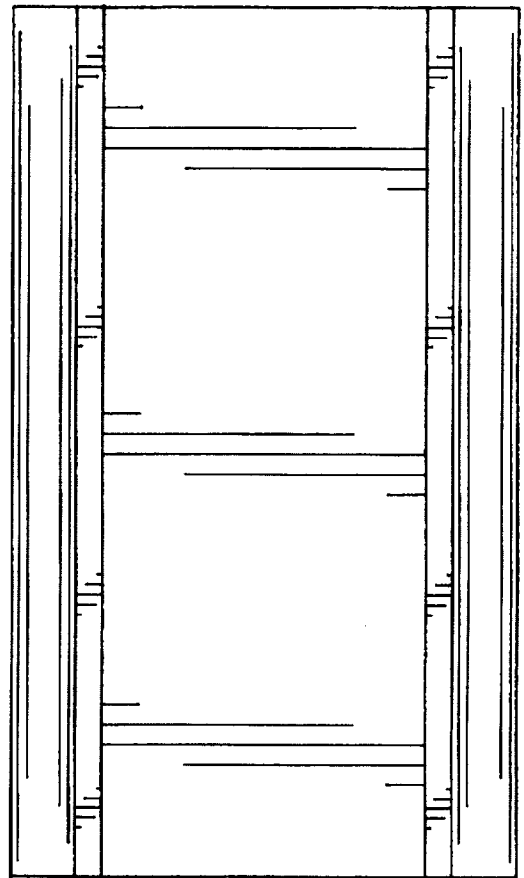

FIG. 7