

(19) World Intellectual Property Organization  
International Bureau



(43) International Publication Date  
23 January 2003 (23.01.2003)

PCT

(10) International Publication Number  
**WO 03/007342 A2**

- (51) International Patent Classification<sup>7</sup>: **H01L 2/00**
- (21) International Application Number: PCT/US02/22375
- (22) International Filing Date: 9 July 2002 (09.07.2002)
- (25) Filing Language: English
- (26) Publication Language: English
- (30) Priority Data:  
09/905,218 13 July 2001 (13.07.2001) US
- (71) Applicant: **TRU-SI TECHNOLOGIES, INC.** [US/US];  
657 N. Pastoria Avenue, Sunnyvale, CA 94086 (US).
- (72) Inventors: **BERGER, Alexander, J.**; 810 Rorke Way,  
Palo Alto, CA 94003 (US). **KRETZ, Frank, E.**; 2052  
Kimbarlin Place, Santa Clara, CA 95051 (US).
- (74) Agents: **SHENKER, Michael** et al.; Skjerven Morrill  
LLP, 25 Metro Drive, Suite 700, San Jose, CA 95110 (US).
- (84) Designated States (*regional*): European patent (AT, BE,  
BG, CH, CY, CZ, DE, DK, EE, ES, FI, FR, GB, GR, IE, IT,  
LU, MC, NL, PT, SE, SK, TR).

**Published:**  
— without international search report and to be republished  
upon receipt of that report

*For two-letter codes and other abbreviations, refer to the "Guidance Notes on Codes and Abbreviations" appearing at the beginning of each regular issue of the PCT Gazette.*



(54) Title: ALIGNMENT OF SEMICONDUCTOR WAFERS AND OTHER ARTICLES

(57) Abstract: A wafer or some other article is aligned while being held by an end-effector.

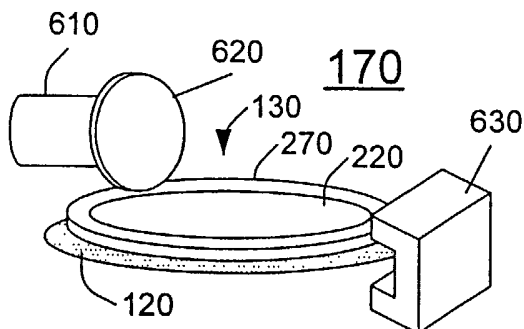

WO 03/007342 A2

## ALIGNMENT OF SEMICONDUCTOR WAFERS AND OTHER ARTICLES

## BACKGROUND OF THE INVENTION

5 The present invention relates to alignment of semiconductor wafers and other articles.

Fabrication of integrated circuits from a semiconductor wafer involves many processing steps, and the wafer may have to be aligned as it goes from one step to the next. For example, before a wafer is diced, it has to be attached to an adhesive film stretched over a frame, which requires accurate alignment of the wafer to the frame.

10 Alignment is performed using a piece of equipment called aligner. A robot picks up the wafer and places it on the aligner. The aligner adjusts the position of the wafer in the horizontal plane to cause the center of the wafer to occupy a predetermined position. Then the aligner rotates the wafer to place the wafer into some predetermined rotational orientation, i.e. with some feature (a notch or a flat) on the wafer's circumference in a

15 predetermined position. Then the robot picks up the wafer again and carries the wafer to a target station for the next processing step.

## SUMMARY

Some embodiments of the present invention eliminate the need to use an aligner. The wafer is aligned while held by the robot. The wafer processing becomes faster and

20 more economical, and throughput is increased. Also, the wafer damage is reduced due to elimination of the wafer transfer to and from the aligner. In addition, the wafer position is more precise at the target station because the positioning errors involved in the robot picking up the wafer from the aligner are eliminated.

The invention is not limited by the embodiments and advantages described above,

25 but is defined by the appended claims.

## BRIEF DESCRIPTION OF THE DRAWINGS

Fig. 1 is a block diagram illustrating a wafer processing system according to one embodiment of the present invention.

Figs. 2, 3 are perspective views of a robot's end effector according to one

30 embodiment of the present invention.

Fig. 4 is a perspective and cross sectional view of a portion of the end effector of Figs. 2, 3.

Fig. 5 is a cross sectional view of the end effector of Figs. 2, 3.

Fig. 6 is a perspective view illustrating an alignment operation according to one embodiment of the present invention.

Figs. 7-9 are top views illustrating an alignment operation according to one embodiment of the present invention.

Fig. 10 is a perspective view illustrating an alignment operation according to one embodiment of the present invention.

## 10 DESCRIPTION OF PREFERRED EMBODIMENTS

In Fig. 1, a semiconductor wafer 120 is being transported from a station 121 to a station 122 by a robot 124. The wafer is being held by the robot's end effector 130 attached to the robot's arm 134. Arm 134 is attached to a robot body 124B which itself may include a number of moving arms. In one example, end effector 130 is attached to a robot of type GBY7S available from Genmark Automation of Sunnyvale, California. The robot is controlled by its computer 140, which in turn may receive commands from, and send information to, a programmable logic controller (PLC) 150. Computer 140 and PLC 150 are controlled by software of the present invention. The invention is not limited to any particular robot or robot control mechanism.

Stations 121, 122 can be any stations involved in wafer storage or processing. Examples include wafer storage cassettes, horizontal wafer shipment containers ("pods"), etch and deposition equipment, film frame machines that attach adhesive film frames to wafers, dicing equipment. Before the wafer is placed on station 122, it is aligned at station 170. Alignment involves adjusting the XY position and the rotational orientation of the wafer relative to end effector 130. See e.g. the following U.S. patents: 6,164,894; 5,456,179; 5,452,078. The wafer is aligned in end effector 130. Alignment station 170 does not need a wafer holder or a platform to hold the wafer. The end effector does not need to release the wafer to perform the alignment.

Fig. 2 is a perspective view showing a top and a side of one embodiment of end effector 130. Fig. 3 shows the same side and the bottom. Fig. 4 shows a vertical cross section of a portion of the end effector along a line IV-IV in Fig. 2. Fig. 5 shows how a vertical cross-section might look along a line V-V in Fig. 2 (Fig. 5 is not an accurate

representation of some features as noted below). Figs. 6-10 illustrate a wafer alignment operation at station 170.

In the embodiment of Figs. 2-5, the end effector is a non-contact type. It holds the wafer with gas vortices emitted from openings 210 (Figs. 3, 5) in its flat bottom surface. Only a few of the openings are labeled in the drawings. Gas vortex end effectors are described in U.S. patent no. 6,095,582 issued August 1, 2000 to Siniaguine et al. and incorporated herein by reference. See also U.S. patent application no. 09/632,236 filed August 4, 2000 by S. Casarotti et al.; U.S. patent application no. 09/633,086 filed August 4, 2000 by S. Kao; U.S. patent application no. 09/877,366 entitled "Article Holders that Use Gas Vortices to Hold an Article in a Desired Position", filed June 8, 2001 by S. Kao. The end effector of Figs. 2-5 has a body 220 made of a top plate 220T and a bottom plate 220B. A number of vortex chucks 230 (Fig. 5) are positioned in a hollow region between the two plates. Each opening 210 is an opening of one such chuck. (Fig. 5 does not accurately represent the chucks' position.) A tangential passage 232 in the chuck's cylindrical sidewall enters the chuck tangentially to the sidewall. Gas supplied under pressure through a passage in arm 134 and an opening 240 enters the chucks through passages 232. The chucks' sidewalls shape the gas flow in each chuck into a vortex. The vortices exit through openings 210 and create an attraction force that draws the wafer towards the body 220. At the same time, the gas creates a cushion that prevents the wafer from touching the body 220.

Top plate 220T has a central portion 250 (Fig. 4) and a peripheral portion 260. Peripheral portion 260 extends sidewise from the bottom of central portion 250 and forms a horizontal shelf surrounding the central portion 250. A ring 270 rotates around the end effector's body 220. Ring 270 has a horizontal portion 270H which slides over the shelf 260. Teflon strip or strips 280 (Fig. 4) are attached to the top surface of shelf 260 and/or the bottom surface of the ring's horizontal portion 270H to reduce friction between the ring 270 and the shelf 260. Vertical portion 270V of ring 270 surrounds the end effector body 220.

Spring steel plates 310 are attached to the top surface of central portion 250 with bolts 320 (Fig. 2). Bolts 320 are inserted into holes 322 (Fig. 4) each of which passes through central portion 250 and terminates inside bottom plate 220B. Each plate 310 physically contacts the top surface of the ring's horizontal portion 270H. The friction between plates 310 and the ring's horizontal portion 270H prevents the ring from rotating uncontrollably around body 220 but allows the ring to be rotated at alignment station 170.

Ring 270 has outward protrusions 330. A pad 340 (Figs. 3,5) is attached to the bottom surface of each outward protrusion. Wafer 120 is pressed against these pads 340 when drawn to the end effector by the gas vortices or other forces (depending on the type of the end effector). The friction between the pads and the wafer prevents the wafer from unintentionally sliding horizontally relative to the end effector. This friction also causes the wafer to rotate when the ring 270 is rotationally driven at alignment station 170.

At station 170, the wafer is moved in the end effector to cause the center of the wafer to coincide with the center of the end effector (we will refer to this stage as "XY positioning"). Then the wafer is rotated in the end effector to align the wafer rotationally. The XY positioning involves techniques similar to those described in U.S. patent application attorney docket no. M-11881 US, entitled "Article Holders and Article Positioning Methods", filed by A.J. Berger and F.E. Kretz on the same day as the present application and incorporated herein by reference. The XY positioning involves the robot pushing the wafer against an object or objects. The wafer slides on pads 340 without the end effector losing hold of the wafer. One embodiment is illustrated in Figs. 6-9. Fig. 6 is a perspective view, and Figs. 7-9 are top views. Here the objects against which the wafer is pushed are two sets of vertical pins. One set of pins consists of pins 510.1, 510.2, 510.3, 510.4 ("pins 510"). The other set consists of pins 520.1, 520.2, 520.3, 520.4 ("pins 520"). Pins 510, 520 are mounted on a support plate 530. Pins 510 are positioned along a circle 540 (Fig. 7) of the same radius as wafer 120. Pins 520 are positioned along a circle 550 of the same radius as wafer 120. Pins 510.1, 510.2 are symmetric to pins 510.4, 510.3 with respect to a horizontal axis 560. Pins 520.1, 520.2 are symmetric to pins 520.4, 520.3 with respect to the same axis 560.

If wafers may have notches or flats, the pins are positioned so that any two of the pins are farther apart than the maximum lateral dimension of the notch or flat. (This is just an exemplary implementation which does not limit the invention. In other embodiments, the pins may be positioned closer to each other than the length of a flat for example.)

As shown in Figs. 6, 7, the end effector brings the wafer 120 to station 170 with the wafer above the pins 510, 520, and the end effector lowers the wafer so that the wafer is positioned between the pins, without touching the pins. The end effector's center CE is positioned at a predetermined point on axis 560. The wafer's center CW may be shifted relative to the end effector's center CE due to a positioning error. The maximum error is determined by a particular application, and may be a function of maximum positioning

errors at source station 121. We will assume, for the sake of illustration, that the maximum positioning error  $E_{max}$  of the wafer in the end effector at the stage of Fig. 6, i.e. the maximum distance between the centers CE and CW, is 1.25 mm. The wafer is positioned so that it does not touch the pins 510, 520 when the error is not more than  
5 1.25 mm.

As shown in Fig. 8, the end effector moves to the left along axis 560 to bring the wafer in contact with pins 510. The pins push the wafer into the circle 540. The wafer slides on the end effector pads 310 and changes its position relative to the end effector until the wafer position coincides with circle 540. In this position, the wafer contacts all  
10 of pins 510, or it may contact three of pins 510 with the fourth pin being against the wafer's notch or flat. To insure that the wafer becomes positioned in circle 540, the center CE of the end effector is moved to the left of the center of circle 540 by the distance  $E_{max} = 1.25$  mm or more, for example, 25 to 51 mm. (In Fig. 7, the center of circle 540 coincides with the center CW of wafer 120.)

As shown in Fig. 9, the end effector now moves to the right along axis 560. The end effector's center CE moves along the axis into the center of circle 550. Wafer 120 comes in contact with at least three of pins 520. Pins 520 steer the wafer into circle 550 as the wafer slides on pads 310. Now the wafer's center CW coincides with the end effector's center CE.  
15

As shown in Fig. 10, station 170 also includes a motor 610 (e.g. a computer controlled stepper or servo motor) which rotates a wheel 620. After the stage of Fig. 9, the end effector moves into a position in which an edge of wheel 620 physically contacts the top surface of the ring's horizontal portion 270H, causing the ring to rotate. A sensor 630 scans the edge of the rotating wafer 120 and provides signals to the computer (not  
20 shown) controlling the motor 610. The signals indicate whether the sensor has detected a notch, a flat, or some other alignment mark on the wafer. Responding to these signals, the computer controls the motor 610 to position the wafer into a desired rotational orientation relative to the end effector. Suitable sensors and motor control algorithms are described, for example, in U.S. patents 6,164,894 (issued December 26, 2000), 5,456,179  
25 (issued August 13, 1996), 5,452,078 (issued September 19, 1995), all incorporated herein  
30 by reference.

When the alignment has been completed, the end effector places the wafer on destination station 122 (Fig. 1).

The invention is not limited to any particular number of pins 510, 520, or their positioning. The pins do not have to be positioned symmetrically with respect to any axis. Also, article 120 and end effector 130 do not have to be round or symmetric. The pins can be replaced by other objects, vertical or otherwise, as described in the  
5 aforementioned U.S. patent application attorney docket no. M-11881. Either pins 510 or pins 520 can be omitted in some embodiments. The invention is not limited to any particular positioning of pins 510, 520, motor 610 or sensor 630 relative to each other. The sensor may be positioned close to the motor, below the motor for example.

In some embodiments, the XY positioning operations of Figs. 6-9 are omitted if  
10 the XY positioning errors are within the allowable tolerances.

The invention is not limited to any particular alignment mechanism at station 170. For example, motor 610 can be coupled to end effector 130 using some other coupling means than wheel 620. Sensor 630 may be a through-beam type, a retroreflective type, a CCD camera, or some other type, known or to be invented.

In some embodiments, station 170 is part of robot 124 or destination station 122. For example, sensor 630, motor 610, and/or wheel 620 can be attached to the end effector or some other part of the robot.

Spring steel plates 310 allow ring 270 and wafer 120 to move up relative to end effector body 220 if the end effector presses the wafer against some surface at station  
20 122. The surface may be that of a sticky tape, e.g. a dicing tape. See the aforementioned U.S. patent application no. 09/632,236 filed August 4, 2000 by S. Casarotti et al., entitled "Detection and Handling of Semiconductor Wafers and Wafer-Like Objects", incorporated herein by reference. Spring steel plates 310 allow the ring and the wafer to yield when the wafer is pressed against the surface, so wafer damage is avoided. The  
25 invention is not limited to any particular number or position of plates 310. Plates 310 can be made of a material other than spring steel, or can be omitted.

The invention is not limited to any particular structures or materials. For example, strips 280 (Fig. 4) can be made of something other than Teflon, or may be omitted or replaced with other friction reducing devices (e.g. bearings). Outward  
30 protrusions 330 on ring 270 can be omitted. Pads 340 can be positioned elsewhere on the ring's bottom surface. The invention is not limited to the presence of shelf 260 in the end effector's body, or to any particular shape of the end effector, or any particular coupling between the end effector body 220 and ring 270. Ring 270 may be replaced with some other rotational member, for example, a half-ring or a number of rotational arms

extending from arm 134. The ring or other member need not surround the body 220. The ring may be positioned under the body. In some embodiments, ring 270 is omitted. The entire end effector 130 is rotatable on arm 134 around a vertical axis passing through the end effector and/or the center of the wafer. The end effector may be a non-vortex  
5 type. For example, the end effector may hold the wafer with a non-vortex gas flow using the Bernoulli effect. The end effector may be of a vacuum type. If the end effector has a rotatable ring 270, gas inlets for creating the vacuum may be located on the bottom of ring 270. The end effector may also hold the wafer with electrostatic or magnetic forces, with a mechanical clamp, or by other means, known or to be invented. The wafer may be  
10 positioned above the end effector. Non-horizontal positioning of the wafer and the end effector is within the scope of the invention.

The invention is not limited to semiconductor wafers. Article 120 may include a stack of wafers bonded together to provide vertical integrated circuits. See U.S. patent no. 6,184,060 issued February 6, 2001 to O. Siniaguine and incorporated herein by  
15 reference. The article may include a combination of semiconductor and non-semiconductor wafers. See U.S. patent application no. 09/791,977 filed on February 22, 2001 by O. Siniaguine and incorporated herein by reference. In other embodiments, the article is a flat-panel display or some other type extending generally along a plane.

The invention is not limited to end effector article holders. Holder 130 may be a  
20 hand-held article holder. A human operator may align the wafer in the end effector by pushing and rotating the wafer with the operator's hand. The operator's hand may push the wafer or the ring 270 or both. Holder 130 may also be part of non-electronically-controlled equipment. Other embodiments and variations are within the scope of the invention, as defined by the appended claims.



## CLAIMS

1. An article alignment method comprising:  
holding an article with an article holder; and  
rotating at least a portion of the article holder around an axis passing through the  
5 article to rotate the article relative to the article holder while the holder is holding the  
article.
2. The method of Claim 1 wherein holding the article comprises pressing the  
article against the holder; and  
rotating at least a portion of the article holder comprises rotating at least a portion  
10 against which the article is pressed.
3. The method of Claim 2 wherein the article holder comprises one or more  
openings through which one or more gas flows are emitted towards the article to attract  
the article to the holder; and  
the article is pressed against one or more protrusions on the holder.
- 15 4. The method of Claim 2 wherein the article is pressed against one or more  
protrusions on the holder; and  
the method further comprises pushing the article against one or more objects to  
cause the article to slide on the one or more protrusions while the holder is holding the  
article.
- 20 5. The method of Claim 1 further comprising transporting the article holder,  
with the article in the holder, to a rotary drive;  
wherein the rotating operation comprises coupling the drive to the article holder to  
transfer a rotary motion of the drive to the article.
6. The method of Claim 5 wherein coupling the drive to the article holder  
25 comprises coupling the drive to a rotational member of the article holder, the rotational  
member physically contacting the article and coupling the rotary motion of the drive to  
the article.
7. A method for article handling, the method comprising:  
picking up an article with an article holder;  
30 sensing, with a sensor, the article's rotational orientation relative to an axis  
passing through the article, and if the rotational orientation is different from a  
predetermined orientation, then rotating the article to place the article into the  
predetermined orientation, wherein the sensing and rotating operations are performed  
while the article is held by the holder.

8. The method of Claim 7 wherein holding the article comprises pressing the article against the holder; and

rotating the article comprises rotating at least a portion of the article holder against which portion the article is pressed.

5 9. The method of Claim 8 wherein the article holder comprises one or more openings through which one or more gas vortices are emitted towards the article to develop an attraction force attracting the article to the holder; and

the article is pressed by the attraction force against one or more protrusions on the holder.

10 10. The method of Claim 8 wherein the article is pressed against one or more protrusions on the holder; and

the method further comprises pushing the article against one or more objects to cause the article to slide on the one or more protrusions while the holder is holding the article.

15 11. The method of Claim 7 further comprising transporting the article holder, with the article in the holder, to a rotary drive;

wherein the rotating operation comprises coupling the drive to the article holder to transfer a rotary motion of the drive to the article.

20 12. The method of Claim 11 wherein coupling the drive to the article holder comprises coupling the drive to a rotational member of the article holder, the rotational member physically contacting the article and coupling the rotary motion of the drive to the article.

25 13. A robot end effector comprising a member rotational relative to the end effector, to allow an article held in the end effector to rotate around an axis passing through the article.

14. The end effector of Claim 13 wherein the end effector further comprises: a body to which the member is coupled and around which the member is rotational; and

30 a device for pressing the article against the member when the end effector is holding the article.

15. The end effector of Claim 14 wherein the device comprises a vortex chuck to emit a gas vortex towards the article.

16. The end effector of Claim 15 wherein the vortex chuck is mounted in the body.

17. A robot end effector comprising a mechanism for holding an article and rotating the article around an axis passing through the end effector.

18. The end effector of Claim 17 wherein the end effector further comprises:  
a body to which the member is coupled and around which the member is  
5 rotational; and  
a device for pressing the article against the member when the end effector is holding the article.

19. The end effector of Claim 17 wherein the device comprises a vortex chuck to emit a gas vortex towards the article.

10 20. The end effector of Claim 19 wherein the vortex chuck is mounted in the body.

21. A computer system programmed to control an article holder and a motor for rotating at least a portion of the article holder to perform the operations of Claim 1.

15 22. A computer readable medium comprising computer instructions to control an article holder and a motor for rotating at least a portion of the article holder to perform the operations of Claim 1.

23. A computer system programmed to control an article holder and a motor for rotating at least a portion of the article holder to perform the operations of Claim 8.

20 24. A computer readable medium comprising computer instructions to control an article holder and a motor for rotating at least a portion of the article holder to perform the operations of Claim 8.

1/7

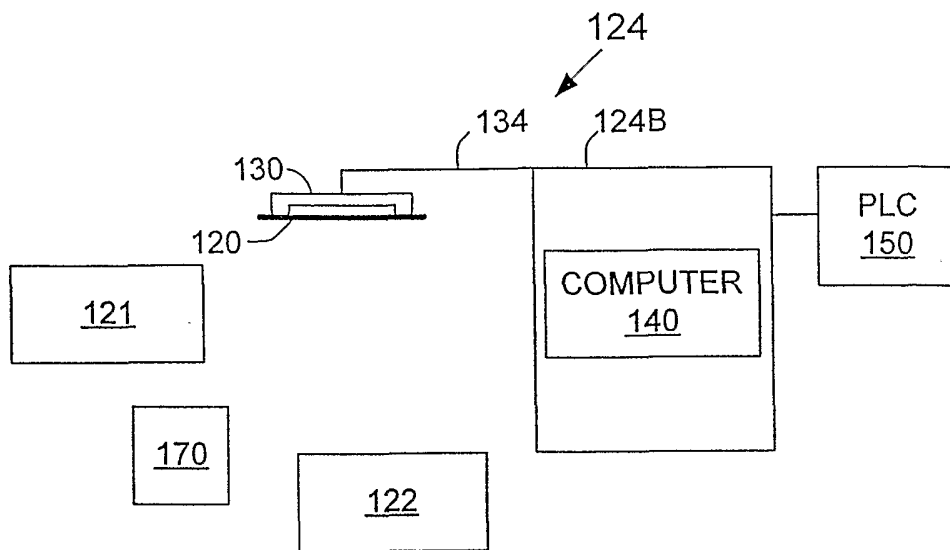

FIG. 1

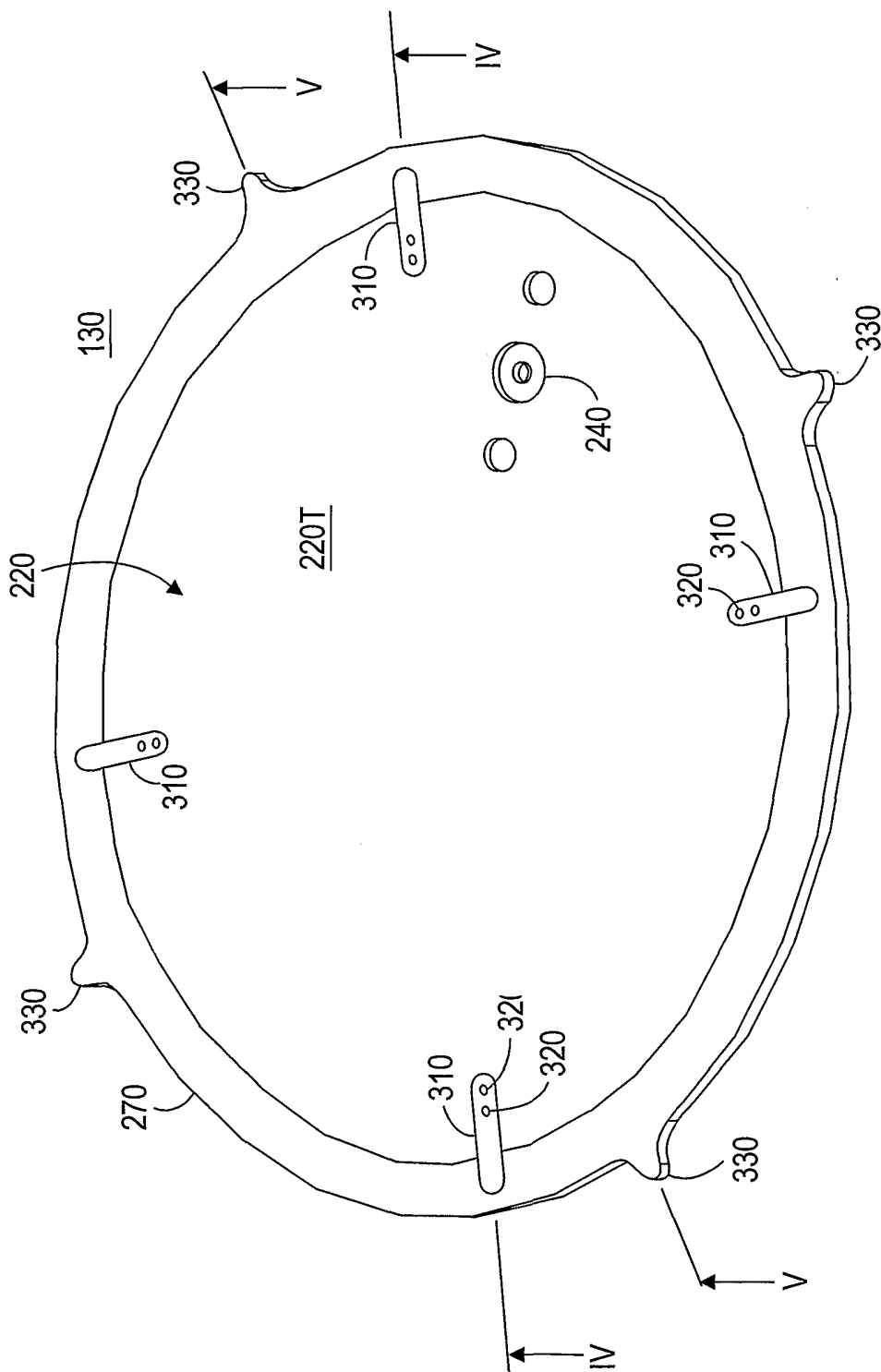

FIG. 2

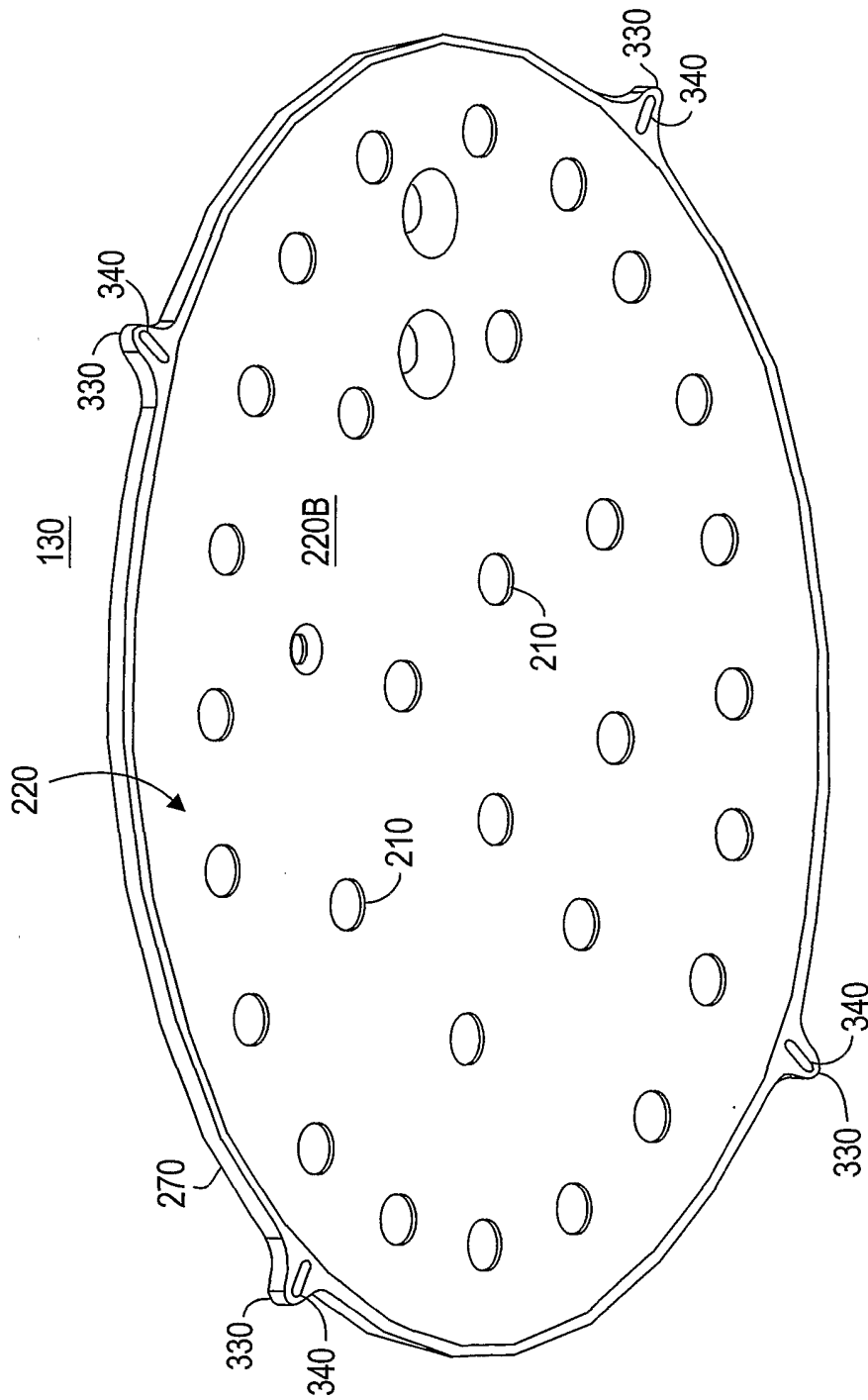

FIG. 3

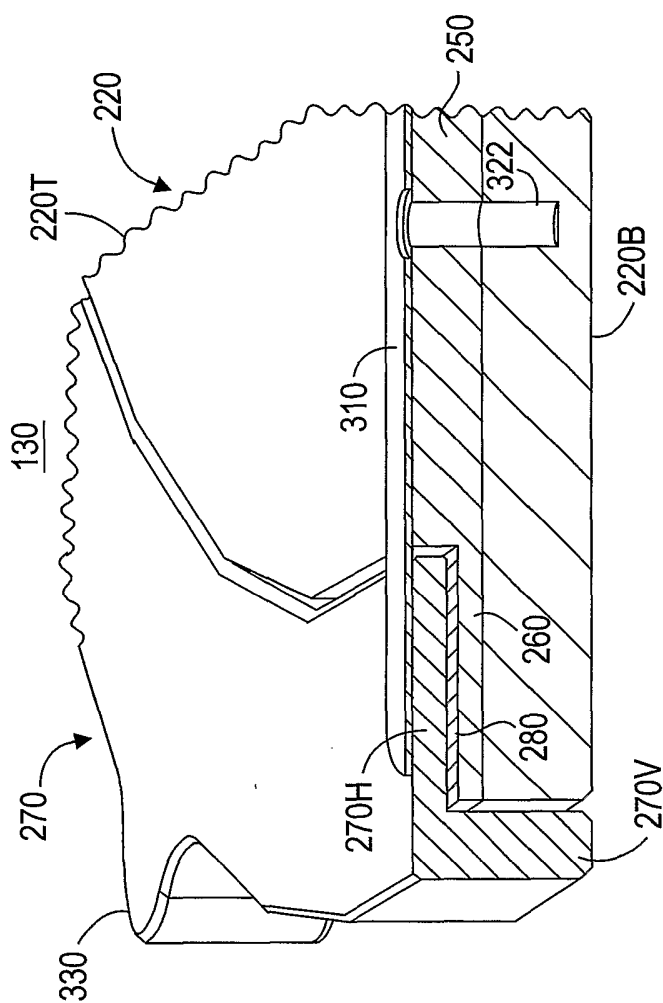

FIG. 4

5/7

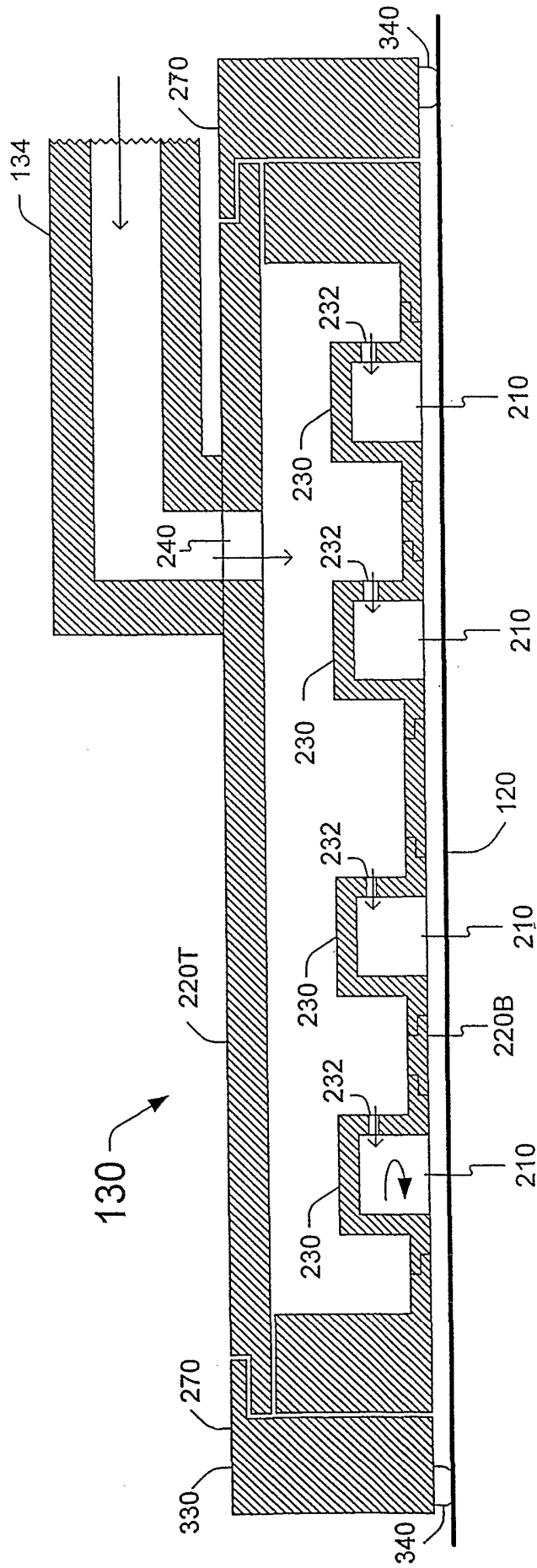

FIG. 5



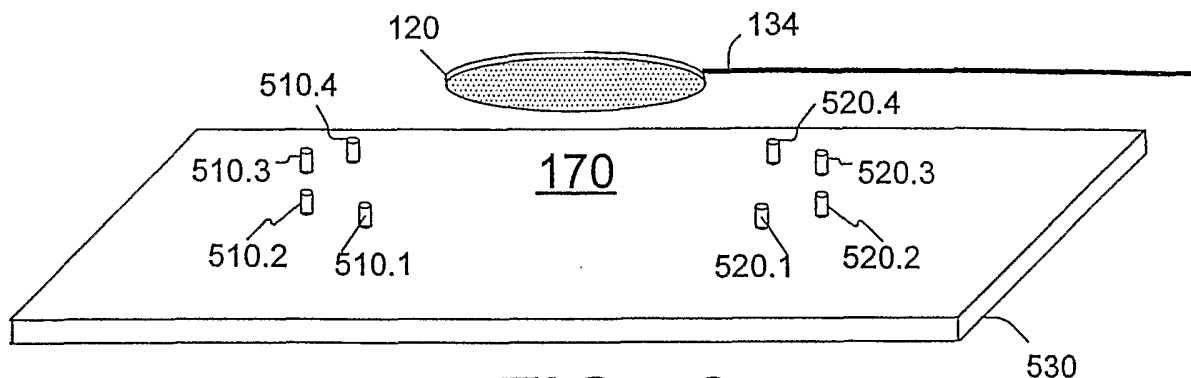

FIG. 6

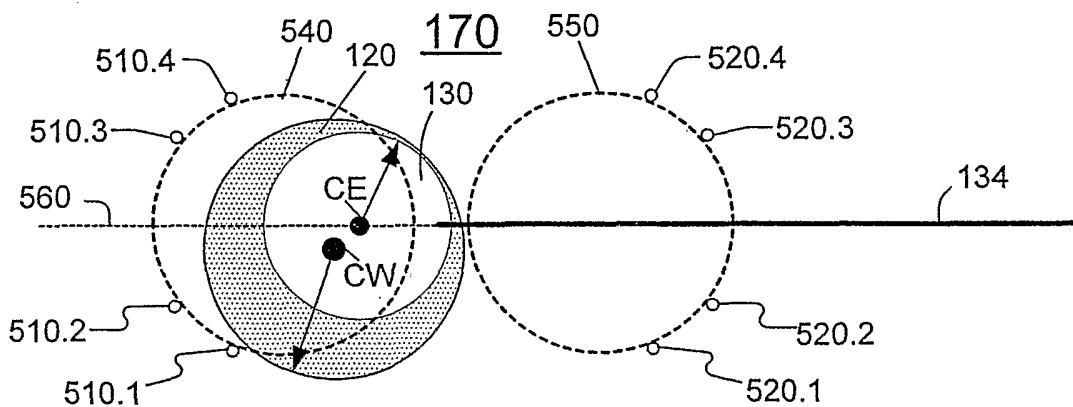

FIG. 7

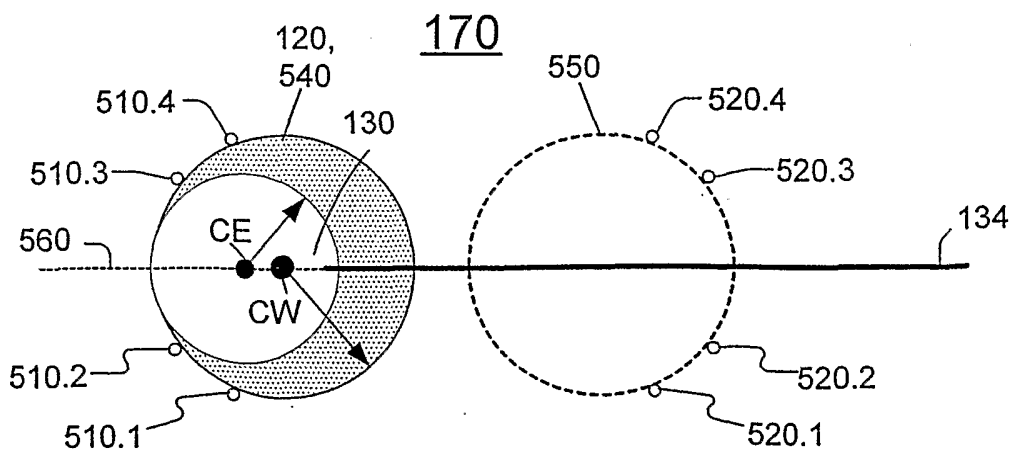

FIG. 8

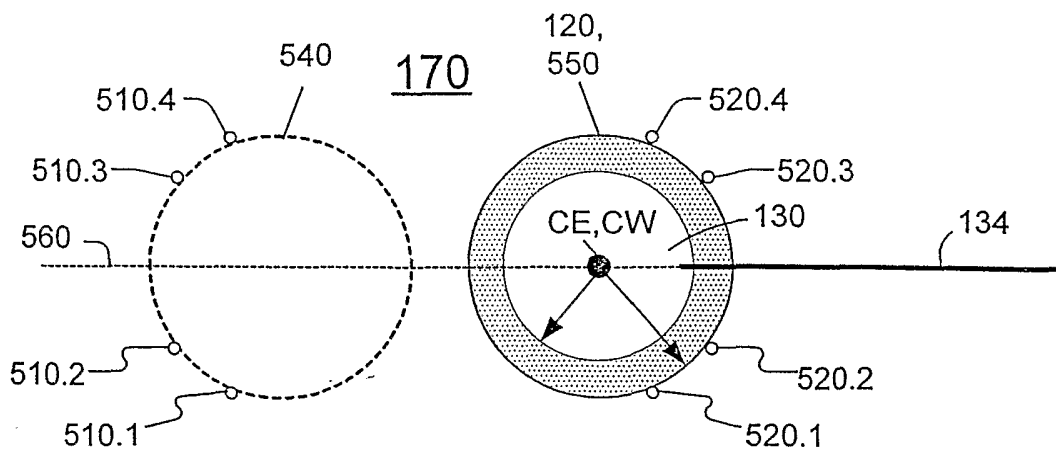

FIG. 9

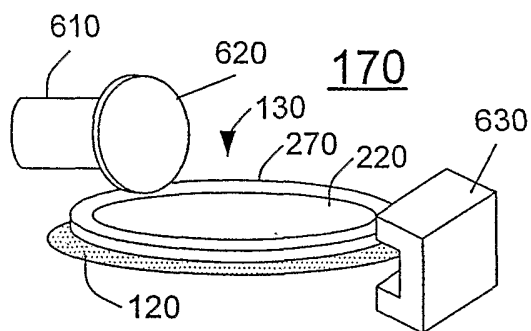

FIG. 10