

(19) World Intellectual Property
Organization
International Bureau



(43) International Publication Date
23 June 2005 (23.06.2005)

PCT

(10) International Publication Number
WO 2005/055860 A1

- (51) International Patent Classification⁷: **A61C 8/00**, A61L 27/06
- (21) International Application Number:
PCT/SE2004/001806
- (22) International Filing Date: 6 December 2004 (06.12.2004)
- (25) Filing Language: English
- (26) Publication Language: English
- (30) Priority Data:
0303323-0 11 December 2003 (11.12.2003) SE
- (71) Applicant (for all designated States except US): **NOBEL BIOCARE AB (PULB)** [SE/SE]; Box 5190, S-402 26 Göteborg (SE).
- (72) Inventor; and
- (75) Inventor/Applicant (for US only): **HALL, Jan** [SE/SE]; Stabbegatan 2A, S-402 26 Göteborg (SE).
- (74) Agent: **OLSSON, Gunnar**; Nobel Biocare AB (publ), Box 5190, S-402 26 Göteborg (SE).
- (81) Designated States (unless otherwise indicated, for every kind of national protection available): AE, AG, AL, AM, AT, AU, AZ, BA, BB, BG, BR, BW, BY, BZ, CA, CH, CN, CO, CR, CU, CZ, DE, DK, DM, DZ, EC, EE, EG, ES, FI, GB, GD, GE, GH, GM, HR, HU, ID, IL, IN, IS, JP, KE, KG, KP, KR, KZ, LC, LK, LR, LS, LT, LU, LV, MA, MD, MG, MK, MN, MW, MX, MZ, NA, NI, NO, NZ, OM, PG, PH, PL, PT, RO, RU, SC, SD, SE, SG, SK, SL, SY, TJ, TM, TN, TR, TT, TZ, UA, UG, US, UZ, VC, VN, YU, ZA, ZM, ZW.
- (84) Designated States (unless otherwise indicated, for every kind of regional protection available): ARIPO (BW, GH, GM, KE, LS, MW, MZ, NA, SD, SL, SZ, TZ, UG, ZM, ZW), Eurasian (AM, AZ, BY, KG, KZ, MD, RU, TJ, TM), European (AT, BE, BG, CH, CY, CZ, DE, DK, EE, ES, FI, FR, GB, GR, HU, IE, IS, IT, LT, LU, MC, NL, PL, PT, RO, SE, SI, SK, TR), OAPI (BF, BJ, CF, CG, CI, CM, GA, GN, GQ, GW, ML, MR, NE, SN, TD, TG).
- Published:
— with international search report

[Continued on next page]

(54) Title: ARRANGEMENT WITH AN IMPLANT AND/OR A UNIT BELONGING TO SAID IMPLANT, AND METHOD FOR PRODUCTION OF THE IMPLANT AND/OR UNIT

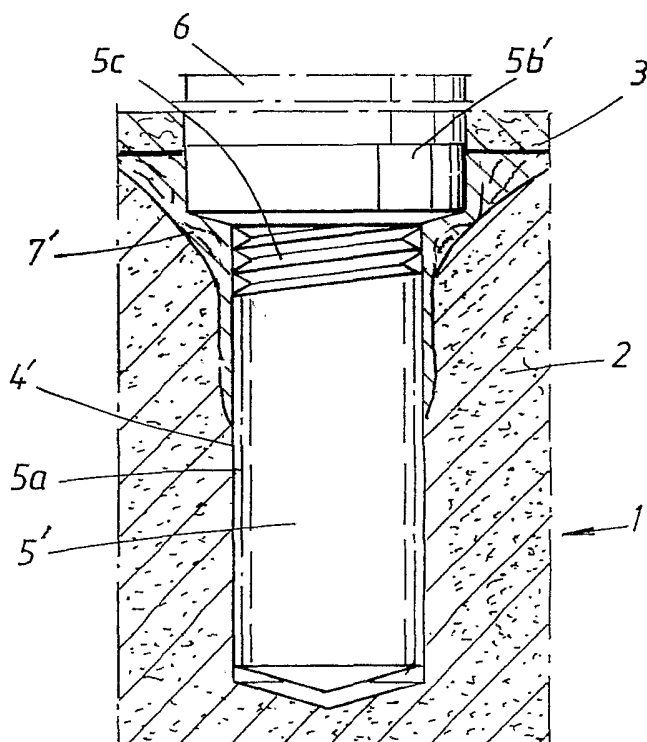

(57) Abstract: An implant (5, 13) and/or a unit (9), e.g. spacer sleeve, belonging to said implant is/are intended to extend through a hole (4') formed in a jaw bone (2) and through soft tissue (3) belonging to the jaw bone and to comprise one or more outer layers of principally titanium dioxide. Each layer consists of crystalline titanium dioxide which largely or completely assumes the anatase phase. The invention also relates to a method for production of such a dental implant (5, 13) and/or of a unit (9) belonging to it, which has one or more outer layers of titanium dioxide. The method is an anodic oxidation method in which the part or parts bearing the outer layer(s) is/are applied to electrolyte under voltage, e.g. comprising sulfuric acid and phosphoric acid, and the voltage (U) and the dwell time of the part or parts in the electrolyte are chosen such that titanium dioxide, largely or completely assuming the crystalline anatase phase, is formed. Excellent bone guidance and soft tissue integration can be achieved in this way.

WO 2005/055860 A1



For two-letter codes and other abbreviations, refer to the "Guidance Notes on Codes and Abbreviations" appearing at the beginning of each regular issue of the PCT Gazette.

Arrangement with an implant and/or a unit belonging to said implant, and method for production of the implant and/or unit

5 The present invention relates to an arrangement with an implant and/or a unit, e.g. spacer sleeve, belonging to said implant, which are intended to extend through a hole formed in a jaw bone and through soft tissue of the jaw bone and to comprise one or more outer layers
10 of titanium dioxide. The invention also relates to a method for production of the implant and/or unit.

Implants and spacer sleeves, or units passing through soft tissue, and methods for production of implants and
15 such units in the dental field are already well known on the market and from descriptions in the patent literature and the general literature. Most of the known implants and units are designed in line with a general attempt to achieve good implantation results at
20 reasonable costs. There is therefore a general need to obtain, between the implant and the jaw bone and between the part of the implant and/or unit extending through the soft tissue and the soft tissue, a good and also esthetically satisfactory integration which does
25 not tend to degenerate after a period of implantation. The same Applicant as the one filing the present patent application has also submitted, inter alia, Swedish patent application 0301149-1, in which excellent integration was made possible between jaw bone and
30 implant. Reference is also made to the patent applications filed at the same time as the present one, namely SE 03322-0 and SE 03324-8.

There is, however, a need for even better implants and
35 units and for methods for production of implants and units. Thus, for example, it is important that bone growth can be improved and accelerated in connection with implants. There is an evident need for short fitting times, and it is more difficult for patients

- 2 -

and dental personnel to accept long and protracted treatment periods. It is also important to achieve a good esthetic result in the long term, and also good integration of the upper parts of the implant or unit with respect to the jaw bone and soft tissue.

The object of the present invention is to solve these problems, inter alia, and it makes use of the knowledge that titanium dioxide can be arranged on the outer surface or outer surfaces of the implant. In a preferred embodiment, the application will be effected by means of so-called anodic oxidation, based on known methods according to Swedish patents 99019474-7 and 0001202-1. However, this known oxidation method has not been proposed to function in the crystalline range. Reference is also made to JP 2000116673 ad JP 11033106, Kokubo et al., relating to implant material which can be used in the crystalline range, but in principle outside the dental field.

The feature which can be regarded as characterizing an arrangement according to the invention is that each of the layers mentioned in the introduction will consist of crystalline titanium dioxide which largely or completely assumes the anatase phase.

In further developments of the inventive concept, the anatase phase is present in a proportion of 70 - 100% in one or more layers. The layers can also have a mean thickness in the thickness range of 0.05 - 10 μm , preferably 0.5 - 10 μm . In one embodiment, a large part or all of the outer surface or outer surfaces of the implant or of the unit is provided with the crystalline titanium oxide largely or completely assuming the anatase phase. In this way, the titanium dioxide layer according to the invention will stimulate excellent bone guidance and soft tissue integration. The crystalline titanium dioxide can be supplemented with another type of substance stimulating bone growth, e.g.

- 3 -

BMP (bone morphogenetic protein). Further embodiments of the novel implant are set out in the attached dependent claims concerning the implant.

5 The feature which can principally be regarded as characterizing the novel method is that it comprises an anodic oxidation procedure. In this method, the part or parts bearing said outer layer or outer layers are applied to a liquid or electrolyte under voltage, e.g.
10 sulphuric acid and phosphoric acid. The electrolyte composition and the voltage and the dwell time of the actual part or parts of the implant in the liquid are chosen so that titanium dioxide, largely or completely assuming the anatase phase, is formed. Different
15 electrolyte compositions are associated with different voltages.

In one embodiment, the voltage is chosen with values between 100 and 270 volts. At lower voltages, the
20 titanium dioxide layer becomes amorphous, and at higher voltages the quantity of rutile in the titanium dioxide layer increases.

By means of what has been proposed above, an excellent
25 and effective bone growth function is obtained which is advantageous both from the point of view of strong growth of bone and from the point of view of time (rapid growth). The layer or layers also provide the possibility of effective soft tissue integration at the
30 part or portion that can be placed against or extend through the soft tissue. The implant production is highly advantageous because methods and procedures already known per se can be used. No modifications are needed to the actual implant or unit structure, and
35 they can be distributed and handled in the manner already practised in the dental field. Likewise, the actual implantation work can follow already established routines, with the difference that bone growth, soft tissue integration and speed are increased. Layers with

different properties can be positioned in all areas or selected areas of the implant, should this be desired.

Presently proposed embodiments of an arrangement and of
5 a method for production of the latter will be described below with reference to the attached drawings, in which:

10 Figure 1 shows a diagrammatic vertical view of an implant provided with a titanium dioxide layer in anatase phase and fitted in a jaw bone (of which part is shown), which layer, compared to the prior art, has an increased ability to guide bone formation,

15 Figure 2 shows a vertical view of an implantation case different than the one according to Figure 1,

20 Figure 3 shows a vertical view of parts of an implant in a jaw bone (of which part is shown) and a through-piece belonging to the implant and extending through soft tissue, and portions of the unit that can be placed against the soft tissue have titanium dioxide layers in anatase phase,

25 Figure 4 shows a diagrammatic side view of titanium dioxide in the anatase phase being applied to an implant by means of anodic oxidation,

30 Figure 5 shows a diagrammatic side view of titanium dioxide in the anatase phase being applied to a unit or soft tissue through-piece belonging to the implant, and

35 Figure 6 shows, in graph form, the layer thickness as a function of the applied voltage value.

According to Figure 1, a bone 1 comprises jaw bone 2.

- 5 -

On top of the jaw bone there is an area of soft tissue 3. The jaw bone is initially provided with a hole, shown symbolically by reference number 4. An implant 5 which can be of a type known per se is arranged in the hole. The implant can thus comprise, for example, an outer thread 5a by means of which said implant can be screwed into the hole 4. The hole can be threaded or unthreaded. The implant is also provided with an upper flange-like portion 5b which has a peripheral surface 5b' that can be placed against the jaw bone in the upper areas 2a thereof. The implant can also comprise or be connected to a unit or soft tissue through-piece 5c, which can consist of or function as a spacer sleeve. On the soft tissue through-piece 5, the implant is intended to support a prosthesis, which is indicated symbolically by reference number 6. The surface of the jaw bone facing the portion 5b is indicated by 2a'.

The implant according to Figure 1 is provided along all or most of its outer surface with a thin layer of titanium dioxide which completely or partially, preferably substantially, assumes the crystalline form anatase. Said anatase has been shown to have a powerful bone-growth-stimulating effect, which in Figure 1 has been illustrated by bone growth 7 surrounding the implant along most of its length. The anatase layer has thus made the surface of the implant able to guide bone formation. The structure of the layer is described in more detail below. In the case according to Figure 1, the titanium dioxide layer has not been applied to the upper parts of the implant, meaning that a small space with soft tissue is present between the portion and the jaw bone as a result of slight bone absorption. Said space 8, which is normally not desirable, has been shown for illustrative purposes.

The implant according to the illustrative embodiment in Figure 2 can have the same basic structure as the implant 5' in Figure 1. In this case, the implant has

- 6 -

titanium dioxide in the anatase phase only at its upper parts 5b' and 5c. The application of titanium dioxide in the anatase phase has brought about considerable bone growth 7' in the area concerned, cf. space 8 in
5 Figure 1. The titanium dioxide in the anatase phase can thus be used to effectively avoid bone absorption in the area according to the space 8 and in this way to avoid bone absorption and subsidence of soft tissue according to Figure 1. This guarantees a good esthetic
10 result even in the long term. Of course, the implant 5' according to Figure 2 can be provided with titanium dioxide along the full outer extent of the implant. In this case, the hole formation has also been shown more clearly and is indicated by 4'. The arrangements shown
15 in Figures 1 and 2 thus use the ability of the anatase layer to guide bone formation, which ability can be extended substantially compared to known dental techniques.

20 Figure 3 shows a unit or through-piece 9 extending through the soft tissue 3. The unit 9 has a length L in the height direction. Along a length l, which can be 2/3 of L, the unit has been provided, on its outer surface part 9a, with a thin anatase layer 10, i.e.
25 with a titanium dioxide layer in the anatase phase. On the remaining part 9b, with length l', of the outer surface, the unit has a thin titanium dioxide layer which can be amorphous, rutile or in the anatase phase. Said remaining outer surface part is directed towards
30 the oral cavity, indicated symbolically by 10. In Figure 3, reference number 11 also symbolically represents oral epithelium which has a limited extent along the surface of the spacer/unit/through-piece. The connective tissue area 12 extends across the greater
35 part of the area or outer surface 9a, 9b and thus corresponds to the outer surface 9a along the extent l. The through-piece 9 can be integrated with or applied in a known manner to the jaw bone implant 13 which in Figure 3 is fitted in a hole formed in jaw bone 2 in

- 7 -

the same way as in the illustrative embodiment according to Figures 1 and 2. The through-piece is also arranged here to support a prosthetic superstructure 14.

5

Figures 4 and 5 show the principle of anodic oxidation, in which use is made of a vessel 15 with liquid containing an electrolyte, e.g. sulfuric acid and phosphoric acid in accordance with the technique indicated in said patent publications. In an anode and cathode arrangement, the implant represents an anode 16, and a contact unit a cathode 17. The implant is designated by reference number 18 and is completely or partially immersed in the electrolyte 19. The anode and the cathode are connected respectively to the plus pole and minus pole of a voltage source which is symbolized by 20. The voltage source can comprise control members of a known type to ensure that the voltage between the anode/implant and the cathode/contact unit located in the electrolyte can be varied if necessary. Thus, the voltage U can, for a certain composition of the electrolyte, be varied or set to a first value in the range of 100 - 270 volts. If the electrolyte has another composition, the value is set to another value which can be in the stated range, i.e. between 100 and 270 volts, so as to obtain on the outer surface or outer surfaces in question a titanium dioxide layer according to the above, which assumes the crystalline anatase phase 7". The implant 18 can be acted on in the direction of the arrows 20, and it will be appreciated that the titanium dioxide layer can be varied in terms of thickness and phase by controlling the voltage value by means of said control members or setting members and by moving the implant in the directions of the arrows 20. The immersion time of the surface or surface parts is also crucial in determining the structure of the titanium dioxide layer.

35

Figure 5 shows the case where a soft tissue through-

piece or unit 1 is coated completely or partially with titanium dioxide in the anatase phase, using equipment according to Figure 4. In the present example, lower parts (cf. 9a in Figure 3) are immersed in the liquid bath or electrolyte 19. Otherwise, the arrangements according to Figures 4 and 5 function in a corresponding manner.

Figure 6 shows how the thickness T can vary as a function of the voltage U for a certain immersion time and for a given electrolyte. The dependence of the layer thickness on, inter alia, the voltage has been represented by the curve 17. The graph also indicates a first voltage point U_1 where the anatase phase occurs for the layer (cf. 7), while U_2 indicates the voltage where the rutile phase occurs.

The thickness of the titanium dioxide layer can be chosen in the range of 0.05 - 10 μm , for example 0.5 - 10 μm . Anatase is present in a proportion of 70 - 100% in the layer in question. The implant and/or the soft tissue through-piece thus has a portion or portions that can be placed against the jaw bone and/or soft tissue. Each such portion can be unthreaded or can be provided with a thread, groove or pattern. Different layers can be provided on locally distinct sites or on top of one another.

To supplement the ability of the anatase to guide bone formation and to aid soft tissue integration, the titanium dioxide layer in anatase can be provided with growth-stimulating substance(s), e.g. BMP, which have bone-inducing properties.

The invention is not limited to the embodiment shown above by way of example, and instead it can be modified within the scope of the attached patent claims.

Patent claims

- 5 1. An arrangement with an implant (5, 13) and/or a unit (9), e.g. spacer sleeve, belonging to said implant, which is/are intended to extend through a hole (4') formed in jaw bone (2) and through soft tissue (3) belonging to the jaw bone and to comprise one or more outer layers consisting
10 principally of titanium dioxide, characterized in that each layer consists of crystalline titanium dioxide which largely or completely assumes the anatase phase.
- 15 2. The arrangement as claimed in patent claim 1, characterized in that anatase is present in a proportion of 70 - 100% in each layer (7).
- 20 3. The arrangement as claimed in patent claim 1 or 2, characterized in that each layer has a thickness in the thickness range of 0.05 - 10 μm , preferably 0.5 - 10 μm .
- 25 4. The arrangement as claimed in patent claim 1, 2 or 3, characterized in that large parts of the outer surface or outer surfaces of the implant and/or of the unit are provided with the crystalline titanium dioxide largely assuming the anatase phase.
30
5. The arrangement as claimed in any of patent claims 1 - 3, characterized in that one or more outer surfaces of the implant and/or unit are provided with the crystalline titanium dioxide largely
35 assuming the anatase phase.
6. The arrangement as claimed in any of patent claims 1 - 5, characterized in that the implant comprises and/or the unit consists of or comprises a portion

- 10 -

which can be placed against the soft tissue and which, by means of its crystalline titanium dioxide layer in the anatase phase, is intended to afford excellent or good soft tissue integration.

5

7. The arrangement as claimed in any of patent claims 1 - 6, characterized in that each titanium dioxide layer in the crystalline anatase phase comprises bone stimulation substance, e.g. BMP, and/or substance (further) stimulating soft tissue integration.

10

8. The arrangement as claimed in any of the preceding patent claims, characterized in that an outer thread located on the implant and/or the unit is provided with outer layers of crystalline titanium dioxide largely assuming the anatase phase.

15

9. The arrangement as claimed in any of the preceding patent claims, characterized in that the portion of the implant and/or unit that can be placed against the soft tissue comprises a threadless outer surface.

20

10. The arrangement as claimed in any of the preceding patent claims, characterized in that the portion or surface (9a) extending through the soft tissue is coated with layers of crystalline titanium dioxide in the anatase phase along, for example, 2/3 of its length, and the remaining length or surface (9b) of said portion constituting a part directed away from the implant can be substantially amorphous, rutile, or also in the anatase phase, and the length section with anatase can interact with the soft tissue in the connective tissue area (12).

25

30

35

11. A method for producing a dental implant (5, 13) and/or a unit (9) belonging to said implant with

- 11 -

one or more outer layers of titanium dioxide, characterized in that it is an anodic oxidation method in which the part or parts bearing said outer layers is/are applied to liquid (10) or electrolyte under voltage, for example comprising sulfuric acid and phosphoric acid, and the voltage (U) and the dwell time of the part or parts in the liquid or electrolyte are chosen such that titanium dioxide, largely or completely assuming the crystalline anatase phase, is formed.

12. The method as claimed in patent claim 11, characterized in that, for a given or predetermined first concentration of electrolyte, the voltage (U) is chosen with a first value in the range of 100 - 270 volts, and in that, at a second concentration or composition of electrolyte, the voltage is chosen with a second value, etc.

13. The method as claimed in patent claim 11 or 12, characterized in that the crystalline titanium dioxide is supplemented with a growth-stimulating substance, e.g. BMP, and/or measures.

Fig. 2

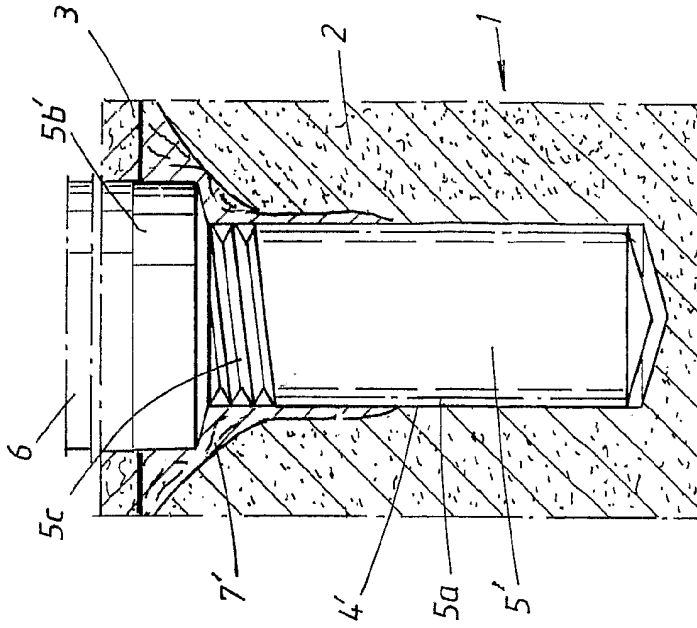

Fig. 1

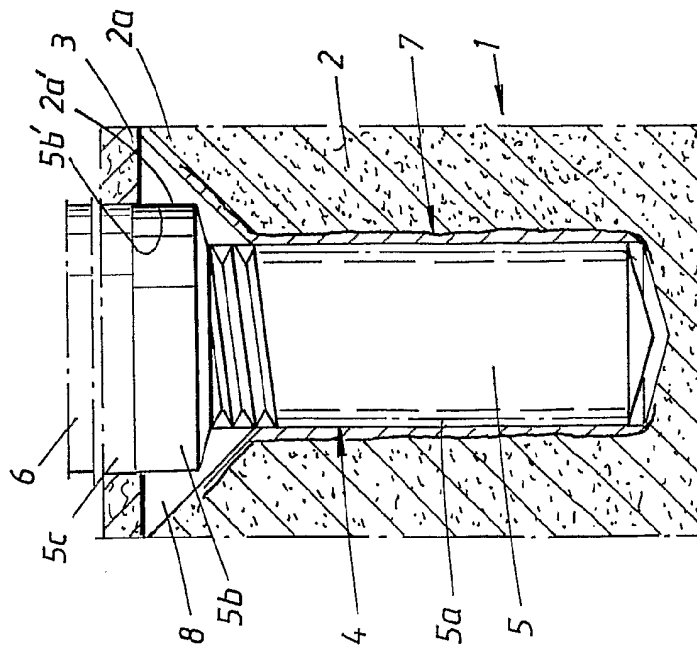

Fig. 3

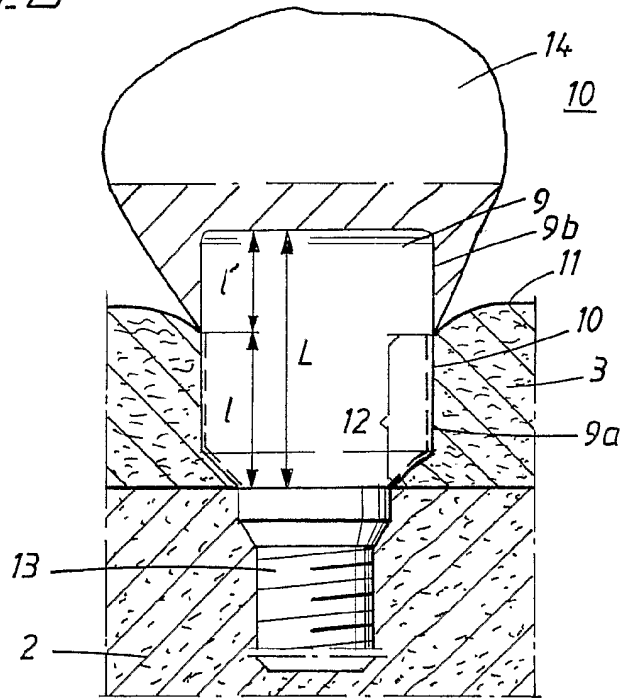

Fig. 4

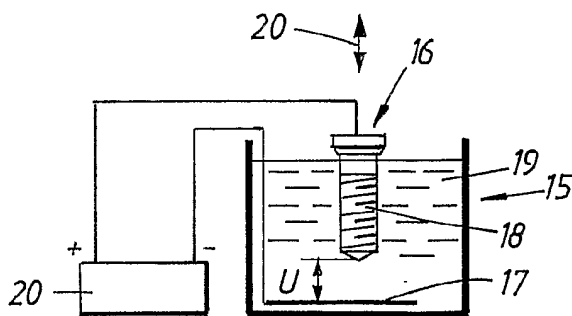

Fig. 5

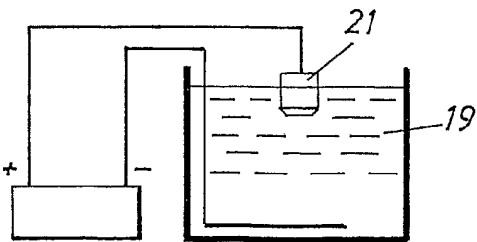
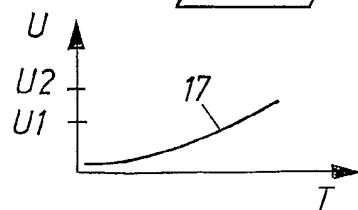

Fig. b



INTERNATIONAL SEARCH REPORT

International application No.

PCT/SE 2004/001806

A. CLASSIFICATION OF SUBJECT MATTER

IPC7: A61C 8/00, A61L 27/06

According to International Patent Classification (IPC) or to both national classification and IPC

B. FIELDS SEARCHED

Minimum documentation searched (classification system followed by classification symbols)

IPC7: A61C, A61F, A61L, A61K

Documentation searched other than minimum documentation to the extent that such documents are included in the fields searched

SE,DK,FI,NO classes as above

Electronic data base consulted during the international search (name of data base and, where practicable, search terms used)

EPODOC, MEDLINE

C. DOCUMENTS CONSIDERED TO BE RELEVANT

Category*	Citation of document, with indication, where appropriate, of the relevant passages	Relevant to claim No.
X	US 6183255 B1 (OSHIDA), 6 February 2001 (06.02.2001), figures 1-9, claims 1-5 --	1-10
X	SE 514202 C2 (NOBEL BIOCARE AB), 22 January 2001 (22.01.2001), page 11, line 4 - page 13, line 16, figures 6-7 --	11-13
A	DE 3445848 A1 (SHERA CHEMIE-TECHNIK GMBH), 19 June 1986 (19.06.1986) --	1-13
A	DE 4216122 A1 (BAYER AG), 18 November 1993 (18.11.1993) -- -----	11-13

 Further documents are listed in the continuation of Box C. See patent family annex.

* Special categories of cited documents:

"A" document defining the general state of the art which is not considered to be of particular relevance

"E" earlier application or patent but published on or after the international filing date

"L" document which may throw doubts on priority claim(s) or which is cited to establish the publication date of another citation or other special reason (as specified)

"O" document referring to an oral disclosure, use, exhibition or other means

"P" document published prior to the international filing date but later than the priority date claimed

"T" later document published after the international filing date or priority date and not in conflict with the application but cited to understand the principle or theory underlying the invention

"X" document of particular relevance: the claimed invention cannot be considered novel or cannot be considered to involve an inventive step when the document is taken alone

"Y" document of particular relevance: the claimed invention cannot be considered to involve an inventive step when the document is combined with one or more other such documents, such combination being obvious to a person skilled in the art

"&" document member of the same patent family

Date of the actual completion of the international search

31 March 2005

Date of mailing of the international search report

06 -04- 2005

Name and mailing address of the ISA/

Swedish Patent Office

Box 5055, S-102 42 STOCKHOLM

Facsimile No. +46 8 666 02 86

Authorized officer

Leif Brander/EK

Telephone No. +46 8 782 25 00

INTERNATIONAL SEARCH REPORT

International application No.

PCT/SE 2004/001806

US	6183255	B1	06/02/2001	NONE
----	---------	----	------------	------

SE	514202	C2	22/01/2001	AU	1433300	A	29/05/2000
				AU	5260800	A	18/12/2000
				CA	2373701	A	07/12/2000
				EP	1191901	A	03/04/2002
				JP	2003500159	T	07/01/2003
				SE	9901974	A	01/12/2000
				WO	0072776	A	07/12/2000

DE	3445848	A1	19/06/1986	NONE
----	---------	----	------------	------

DE	4216122	A1	18/11/1993	FR	2691143	A,B	19/11/1993
				US	5468463	A	21/11/1995
