

E. HARRIS.
RING SPINNING FRAME.

No. 257,320.

Patented May 2, 1882.

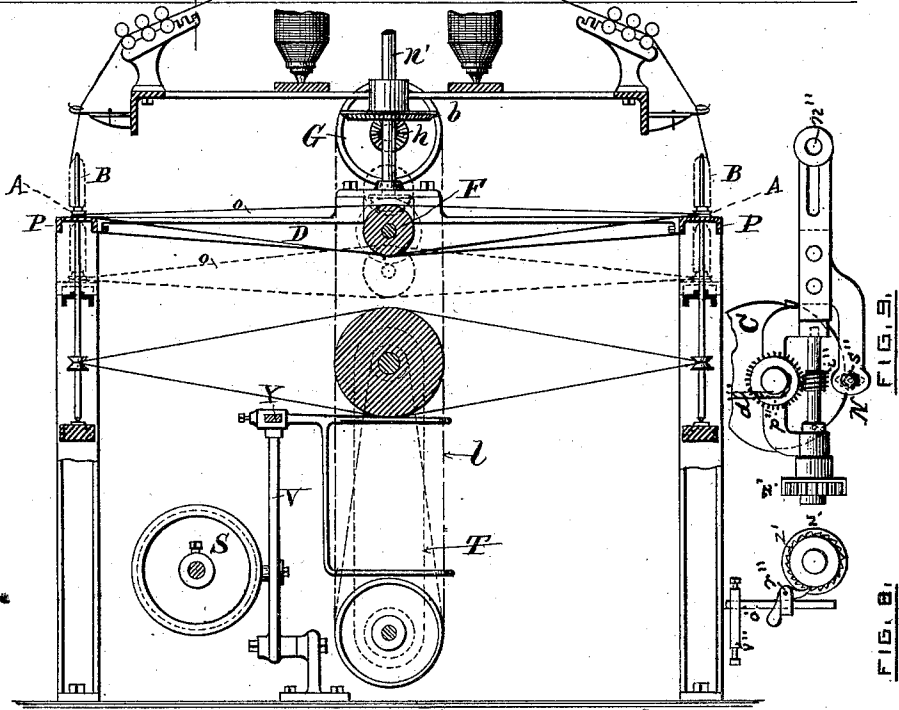
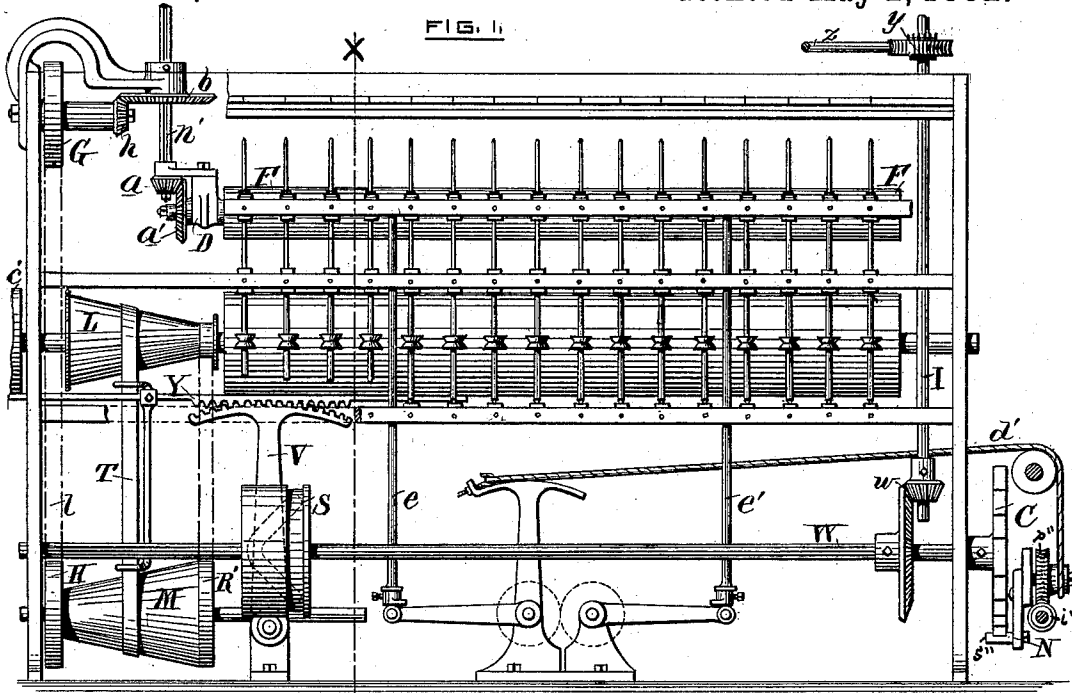

WITNESSES:

FIG. 2.

INVENTOR,

Benj Arnold
at Harris

Elisha Harris

(No Model.)

2 Sheets—Sheet 2.

E. HARRIS.

RING SPINNING FRAME.

No. 257,320.

Patented May 2, 1882.

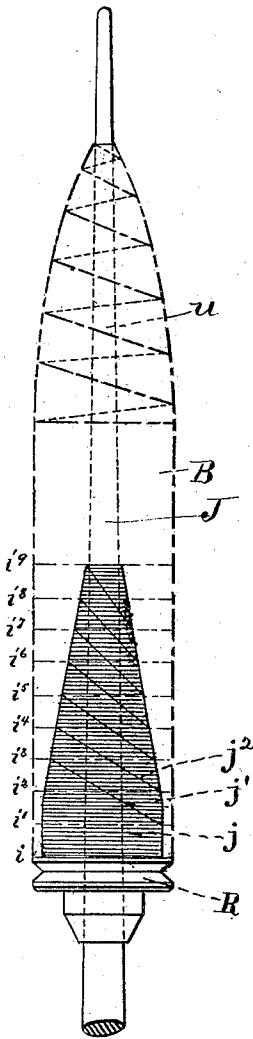

FIG. 4.

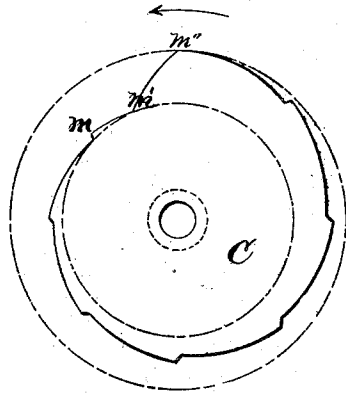

FIG. 6.

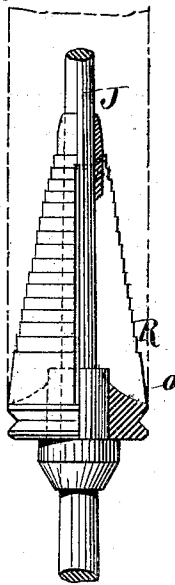

FIG. 5.

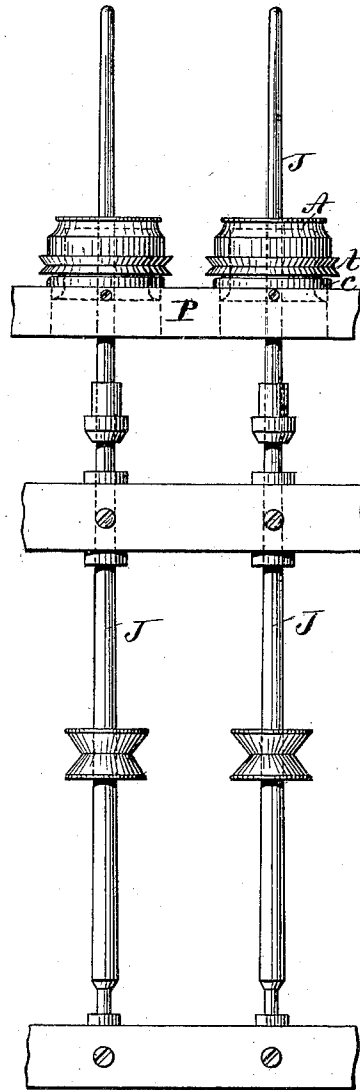

FIG. 3.

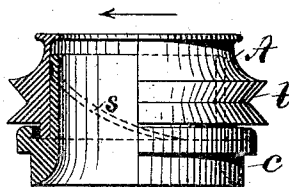

FIG. 7.

WITNESSES,

Benj Arnold
Edw Harris

INVENTOR,

Elisha Harris

UNITED STATES PATENT OFFICE.

ELISHA HARRIS, OF PROVIDENCE, RHODE ISLAND, ASSIGNOR TO HIMSELF
AND ABRAHAM W. HARRIS, OF SAME PLACE.

RING-SPINNING FRAME.

SPECIFICATION forming part of Letters Patent No. 257,320, dated May 2, 1882.

Application filed May 16, 1881. (No model.)

To all whom it may concern:

Be it known that I, ELISHA HARRIS, of the city and county of Providence, in the State of Rhode Island, have invented certain new and useful Improvements in Ring-Spinning Frames, of which the following is a full and correct description, reference being had to the accompanying drawings, forming a part of this specification.

This invention is intended as an improvement upon that described in the Letters Patent granted to me October 5, 1880, No. 232,818, and has for its object the production on a ring-and-traveler spinning frame of a cop of yarn for weaving, similar to those made on mules, and equally capable of bearing the necessary handling after leaving the spindle, without liability of breaking or of other disarrangement.

In the drawings, Figure 1 shows a front elevation of the spinning-frame. Fig. 2 is a vertical cross-section of the frame, taken on the line *x*, Fig. 1. Fig. 3 is an enlarged representation of two spindles and the parts that support them. Fig. 4 is a view of a spindle and cop, showing the direction of the filling and binding courses of the yarn in making the cop. Fig. 5 shows part of a spindle with a bobbin thereon. Fig. 6 is the traverse-cam that controls the motions of the ring-rails. Fig. 7 is a ring with its support, a part of each being removed to show their structure. Figs. 8 and 9 show the take-up motion, hereinafter referred to.

The great difficulty to be overcome in spinning a cop of yarn for weaving on a ring-spinning frame is the great strain on the yarn in carrying the traveler around the ring while winding on the smallest part of the cop or spindle, for at that time the yarn is drawing on the traveler in a direction almost directly toward the center of the ring, and nearly at right angle to the path of the traveler around the ring. Consequently the yarn has but little tendency to carry the traveler forward, and it also cramps the traveler, thereby increasing its friction on the ring and the friction of the yarn in the traveler. The great strain thereby thrown on the yarn causes it to break, and, where it does not so break, it strains the yarn and makes weak places that are liable to break in weaving. While winding on the large part of the

cop the yarn draws on the traveler in a direction almost coincident with its course around the ring, and consequently but little strain is thrown on the yarn in carrying it forward. To obviate this difficulty and produce a uniform tension on the yarn at all times, a rotary motion is given to the ring itself in the same direction as that of the traveler, and this motion is increased as the winding of the yarn approaches the smallest part of the cop. This prevents the increase of the tension of the yarn by assisting it in carrying the traveler. As the winding of the yarn returns to the large part of the cop the motion of the ring decreases, and the friction of the traveler on the ring is restored as the change in the direction of the yarn in passing from the smaller to the larger part of the cop or bobbin increases the facility of carrying it forward by the yarn.

In winding a cop for weaving (shuttle-cop) the usual way is to wind fine or close courses in the upward traverses to fill the cop, and open courses in descending, for the purpose of binding the different parts of the cop together, as the yarn in the open courses lies more in the direction of the axis of the cop. To increase the strength of the cop still further I divide the upward traverses of fine courses into a series of short upward traverses of fine courses and downward open binding-courses that overlap each other, as follows: Starting at the base at *i*, Fig. 4, the yarn is wound in fine courses, lines *j*, upward until it reaches the point *i*³. Then it is carried down back to the line *i*¹ in open binding-courses, (shown by the lines *j*¹.) Then the yarn is again wound in fine courses up to the point *i*². Then it descends in open courses to the line *i*². The yarn is thus wound in a series of short traverses, rising through three of the spaces in fine courses and falling back through two spaces in open courses, thus gaining a space in each rise until it reaches the point *i*², that being the extent of the first of the usual upward traverses. From this point *i*² the yarn descends in the usual open binding-courses nearly to the point *i*, from which it started. The nature of this last open course is shown by the partly-dotted lines *u*, which are placed in the drawings on another part of the cop to prevent confusion with the lines *j*¹ *j*² of the short traverses. Thus the cop being made

up of the usual series of traverses and having the additional short overlapping courses, as described, is rendered very strong. These traverse motions are produced by the cam C, Fig. 6, in which the usual long traverse is divided into short ones by the points and spaces thereon shown, the declines between the points causing the slow upward traverses of the fine courses of yarn, and the points causing the quick descending open courses $j' j^2$. (See Fig. 4.) The spaces between the points on the cam are equal, except that from m to m' , which is made shorter, as it is the last of the short series, and there is no further gain upward. The descent between m^2 and m' on the cam C causes the usual descending binding-courses, (represented by the lines u , Fig. 4,) and each revolution of the cam gives one of the usual long traverses, each succeeding one being, as usual, made a little higher up on the cop by means of the usual take-up motion between the ring-rail and the traverse-cam. The parts of this take-up motion are shown in Figs. 8 and 9, and consist of the lever N, having a pivot-hole at n'' , on which it swings, and is divided into two parts or arms, the lower arm having the stud S'' , that bears on the edge of the cam C, fast in its end. The upper part of the lever has a short shaft holding the worm-wheel i'' , having a bearing in the end of the lever and in a socket in the middle of the lever. A worm-gear, p'' , is secured to the arm on the stud L, so as to engage in the worm i'' , and to the hub of this worm-gear is fastened the cord or chain d' , that raises the ring-rails, so that when the worm-wheel i'' is turned in one direction the cord d' will be taken up on the hub of the gear p'' . A ratchet-wheel, z' , is fastened on the outer end of the shaft to which the worm i'' is fast, and a pawl, r'' , is held by the rod o'' , which is secured to the frame of the machine in such a position that the pawl r'' shall catch in the ratchet-wheel z' and turn it a little as the wheel passes up by it.

The operation is as follows: Every time the traverse-cam C raises the ring-rails by depressing the lever N, the ratchet-wheel z' is carried down past the pawl r'' , and on the upward return motion the pawl causes the ratchet-wheel to turn a little way. This, by means of the worm i'' , turns the wheel p'' and takes up a portion of the cord d' , so that the ring-rails are raised a little higher at each revolution of the cam C, and when the upper end of the cop or bobbin is reached and it is ready to doff, the cord d' is let out to its full length again by turning the ratchet-wheel z' backward, and this lets the ring-rails down, so as to start from the lowest point again. During these traverse motions the speed of the rotary motion of the rings is made to correspond therewith—that is, the rotary motion of the rings is increased as the winding of the yarn approaches the smallest part of the cop and decreases as the winding returns to the larger part. The cam C imparts motion to the ring-rails through the lever N, cord or chain d' , rods $e e$, in the usual

way in ring-spinning frames. The cam S is fast on the shaft W, and is so shaped as to give the changes of rotary motion to the rings by shipping the belt T from the loose pulley R', on the lower cone-shaft, out and in on the cones L M by means of the lever V and the rack-rod Y, to which the belt-guides are attached, so that these motions correspond with the traverse motions given to the ring-rails by the cam C, which is fast on the same shaft. The shaft W is driven by the bevel-gears w , shaft I, gear and worm y , and shaft z , which receives motion from the pulley c' or any other convenient part of the machine. The rings A receive their rotary motion, by means of the bands $o o$, from the cylinder F, which is placed in bearings on the cross-bars D, which extend across from one ring-rail to the other, by means of which arrangement the cylinder is made to rise and fall by the ring-rails and keep the bands always at the proper tension.

Motion is given to the cylinder F by means of the belt l , running from the pulley H on the lower cone-shaft to the pulley G on a stud at the top of the frame, and a bevel-gear, h , secured to the hub of the pulley G, drives the bevel-gear b , which has a bearing on its hub held by an arm from the end of the frame. A short upright shaft, n' , held in a bearing on the cross-bar D, slides freely through this bevel-gear b , which gives it a rotary motion by means of a slot and spline, which motion is transmitted to the cylinder F by the bevel-gears $a a'$. This arrangement allows the cylinder to rise and fall with the ring-rails while running.

The ring A, Fig. 7, revolves on the hollow support e , which extends up inside of the ring, and is secured in the ring-rail in the same way that the rings usually are, so as to admit of the bobbin passing through the same.

A groove, s , for the purpose of oiling the bearing is made in the surface of the bearing, descending in the same direction that the ring revolves, to prevent an overflow of oil from reaching the traveler, and a score or groove, t , is made in the periphery of the ring to receive the band o , that rotates it. The rolls and other parts of the machine, a description of which is not deemed necessary to a complete understanding of my improvements, are constructed and operated in the usual manner in which the ring-and-traveler spinning-frame is made and operated.

The cylinder F may be placed in bearings detached from the ring-rails, and provided with mechanism to give it a vertical motion, so long as that motion agrees with the traverse motion of the ring-rails and keeps the bands that drive the rings always at a proper tension.

Having thus described these improvements, what I claim as my invention, and desire to secure by Letters Patent, is—

1. In a ring-spinning frame, the combination of a ring-rail having hollow supports fastened to it for the rings to revolve upon, and allowing the bobbin to pass through the same, a ring fitted for a traveler and grooved to re-

ceive a band, and a horizontal band-cylinder having vertical motions in unison with the ring-rails, with mechanism for imparting such motion and rotating said cylinder, substantially as herein set forth.

5 2. The traverse-cam C, constructed as herein shown and described—that is, with a series of short rises and declines in its periphery, substantially as herein set forth.

10 3. The traverse-cam C, constructed with a series of short rises and declines, as described, and a ring-rail combined with mechanism for operating said cam, and for imparting motion from the same to said ring-rail, essentially as
15 set forth.

4. The combination, with a ring-rail, a series of ring-holders mounted thereon, a series of

rings adapted to rotate upon said holders, a movable and rotatable driving-cylinder, F, and a series of bands for connecting said cylinder 20 with the rings, of mechanism for imparting a rising and falling motion to said ring-rail and cylinder, and for imparting a variable rotation to the latter, whereby the rings and ring-rail are properly traversed, the driving-cylinder 25 caused to move in unison therewith, and the rings caused to rotate with a variable rotation in relation to the movement of the ring-rail, as specified.

ELISHA HARRIS.

Witnesses:

BENJ. ARNOLD,
ABRAHAM W. HARRIS.