

(No Model.)

W. H. WHEELER.
HALTER.

No. 423,974.

Patented Mar. 25, 1890.

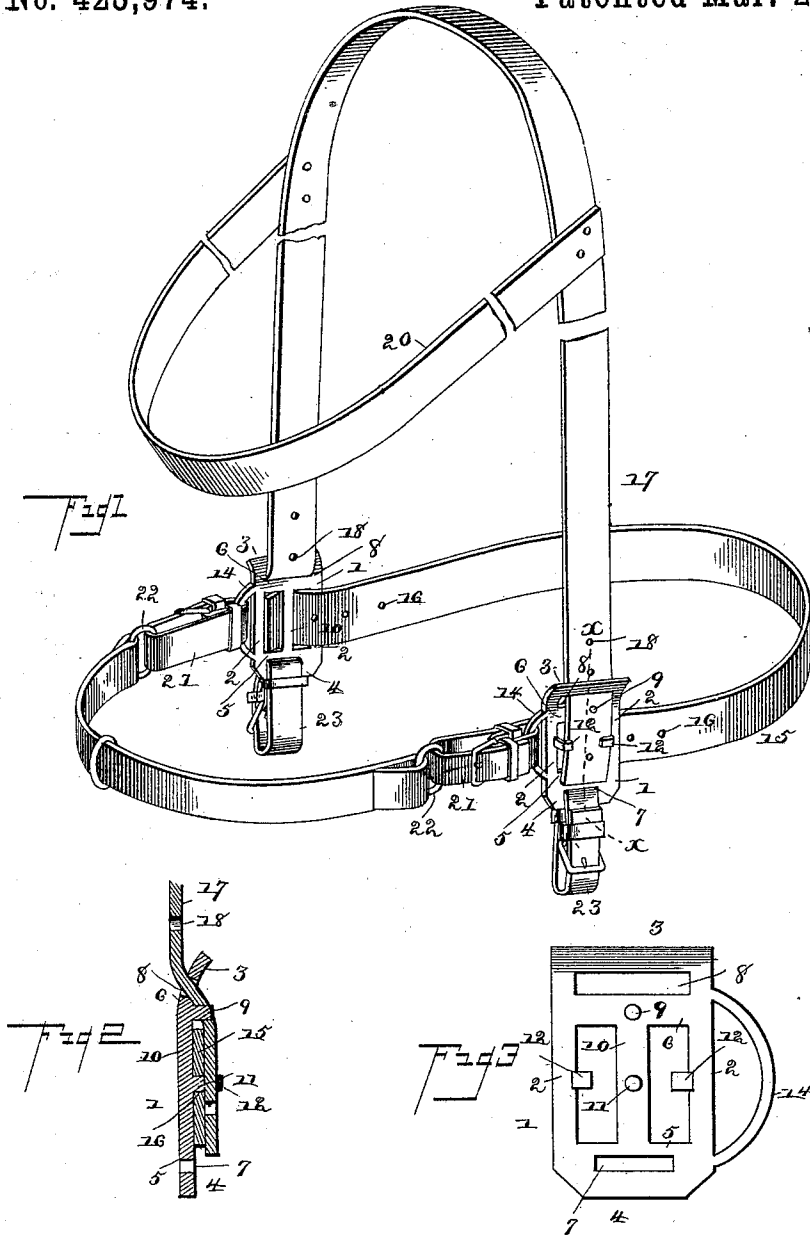

Witnesses:

John Amue
W. Duwall

By his Attorneys,

Inventor

William H. Wheeler

C. Snow & Co.

UNITED STATES PATENT OFFICE.

WILLIAM HENRY WHEELER, OF MOHAWK VILLAGE, OHIO.

HALTER.

SPECIFICATION forming part of Letters Patent No. 423,974, dated March 25, 1890.

Application filed July 11, 1889. Serial No. 317,109. (No model.)

To all whom it may concern:

Be it known that I, WILLIAM HENRY WHEELER, a citizen of the United States, residing at Mohawk Village, in the county of Coshocton and State of Ohio, have invented a new and useful Halter, of which the following is a specification.

This invention has relation to an improvement in halters, and has particular reference to the means for connecting the terminals of the nose-strap with those of the crown-strap.

Although I have herein illustrated and described my invention as applied to halters, it will be apparent that other straps in other portions of harnesses may be likewise connected.

The objects and advantages of the invention, together with the novel features thereof, will be hereinafter described, and particularly pointed out in the claim.

Referring to the drawings, Figure 1 is a perspective of a halter provided with a buckle constructed in accordance with my invention. Fig. 2 is a sectional view on the line *x x* of Fig. 1. Fig. 3 is a detail in plan of the buckle detached.

Like numerals of reference indicate like parts in all the figures of the drawings.

In practicing my invention I construct the buckle 1 of an integral piece of metal, and the same comprises opposite longitudinal side bars 2, connected at one end by a transverse bar 3 and at its opposite end by a similar bar 4, and intermediate said end bars 3 and 4, and near the same, I locate transverse bars 5 and 6, thus forming an opening 7 adjacent to the bar 4, and a wider transverse opening 8 adjacent to the bar 3. Upon the last mentioned of the transverse bars I locate a lug 9, which projects upwardly therefrom. The two transverse intermediate bars are connected longitudinally by a bar 10, and from the center of said longitudinal bar there projects upwardly a lug 11. From each of the longitudinal side bars 2, and at about the center of the space formed by the two intermediate transverse bars, there projects an inwardly-disposed keeper or lug 12. This completes the buckle, with the exception of a lateral loop 14, extending from the lower of the side bars 2.

15 represents the nose-band, the opposite terminals of which are each passed through

the lateral opening formed by the longitudinal central bar of the buckle, and one of the openings 16 in said strap receives the upwardly-projecting lug or tongue, whereby the nose-band may be regulated as to size.

17 represents the crown-strap, which is passed through the transverse opening 8 from the under side under the opposite lugs 12; where it terminates, or may be drawn farther through the buckle, leaving a portion of the crown-strap projecting below the same. One of the openings 18 of the crown-strap receives the tongue or lug 9, formed upon the transverse bar 6.

From the crown-strap there projects the usual throat-latch 20.

21 represents opposite buckle-loops, which are connected to the usual rings 22, said loops being connected with the lateral loop 14, and thus forming the chin-strap.

23 represents a bit-strap occurring at the ends of a bit, said straps being passed through the lower or smaller opening 7, whereby the halter may be used as an ordinary bridle.

When the bit is not in use, the same may be disconnected from the buckle.

Having described my invention, what I claim is—

As an improvement in halters, the combination of the crown-strap having the throat-latch attached thereto, the nose-strap, the buckles connecting the ends of the crown-strap and nose-straps at their point of intersection, said buckles consisting each of a rectangular frame having transverse cross-bars connected by a longitudinal bar provided with upwardly-extending studs, the side bars of said frame being provided with inwardly-disposed keepers and one of said side bars being additionally provided with an outwardly-extending loop, the buckle-loops mounted in said outwardly-extending loops and having the rings, and the chin-strap having its ends arranged in said rings, substantially as and for the purpose herein set forth.

In testimony that I claim the foregoing as my own I have hereto affixed my signature in presence of two witnesses.

WILLIAM HENRY WHEELER.

Witnesses:

J. J. PARRISH,
REUBEN PHILLIPS.