

[54] WIRE COILING TOOL

[75] Inventor: Ernst Pfaffle, Neuffen, Germany  
[73] Assignee: Hans Sickinger Company, Pontiac, Mich.  
[22] Filed: Mar. 8, 1973  
[21] Appl. No.: 339,408

Related U.S. Application Data

[63] Continuation-in-part of Ser. No. 248,747, April 28, 1972, abandoned.  
[52] U.S. Cl. .... 140/92.3, 72/142.  
[51] Int. Cl. .... B21f 3/02  
[58] Field of Search ..... 140/92.3, 92.7, 92.93, 140/92.94; 72/142, 135, 137

[56]

References Cited

UNITED STATES PATENTS

3,404,711 10/1968 Whitcomb ..... 140/92.3  
3,520,334 7/1970 Mueller ..... 140/92.3

Primary Examiner—Lowell A. Larson  
Attorney, Agent, or Firm—Harness, Dickey & Pierce

[57]

ABSTRACT

A wire coiling tool having a cylindrical mandrel with inwardly extending guide pins and a wire preforming tool. This tool bends the wire to a smaller radius of curvature than the mandrel, so that the wire will grip the mandrel and be driven thereby.

7 Claims, 7 Drawing Figures

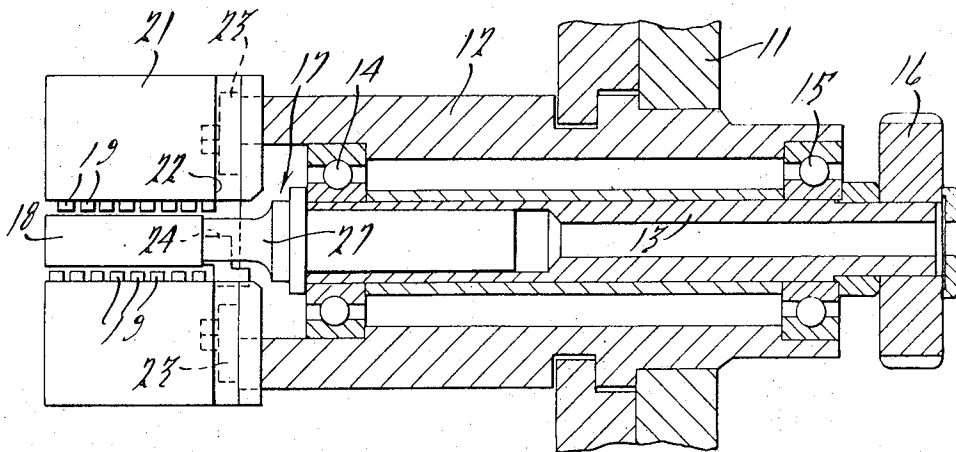

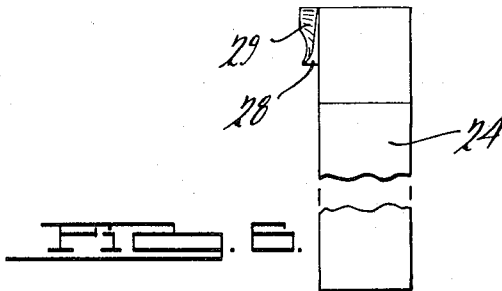
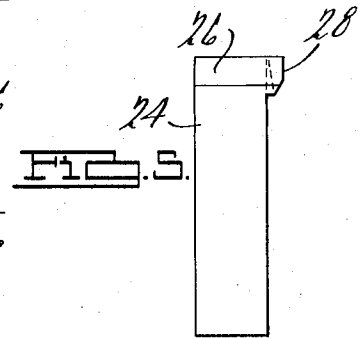
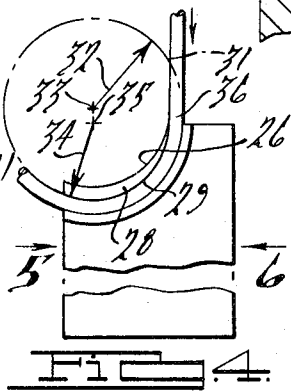
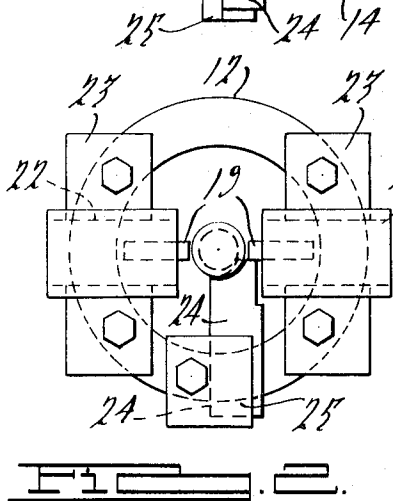
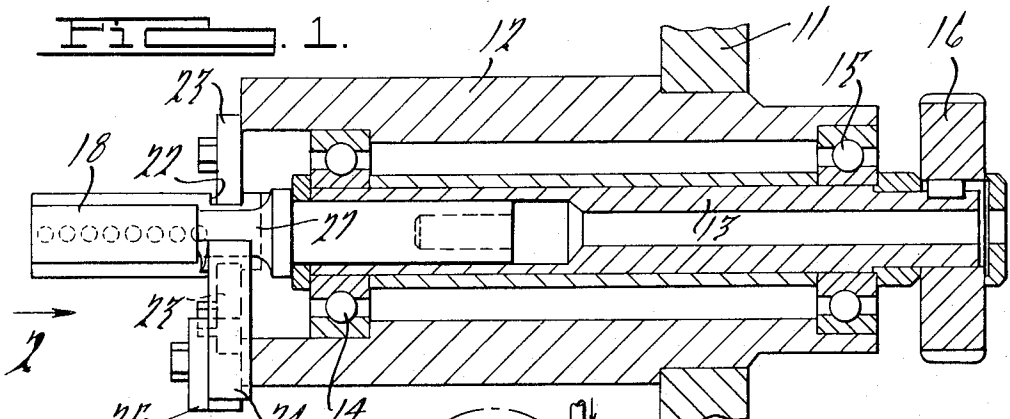
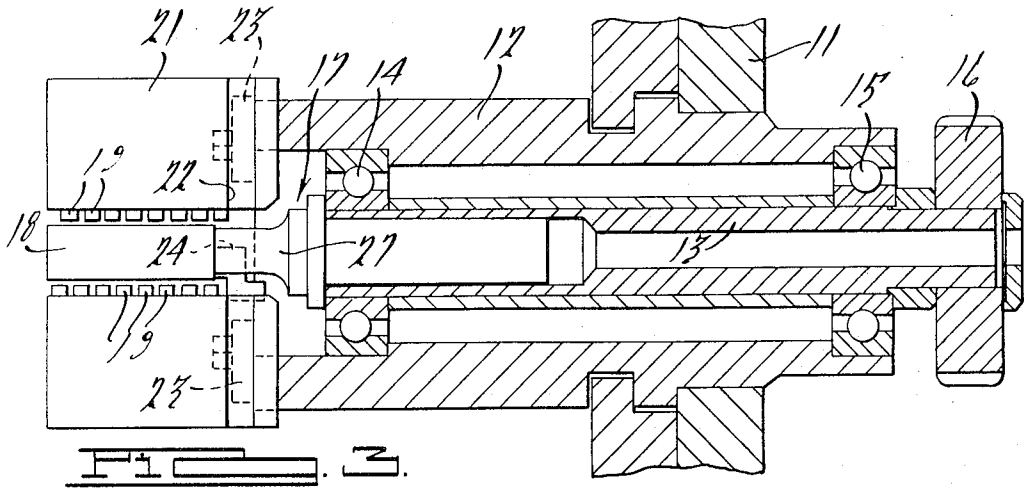

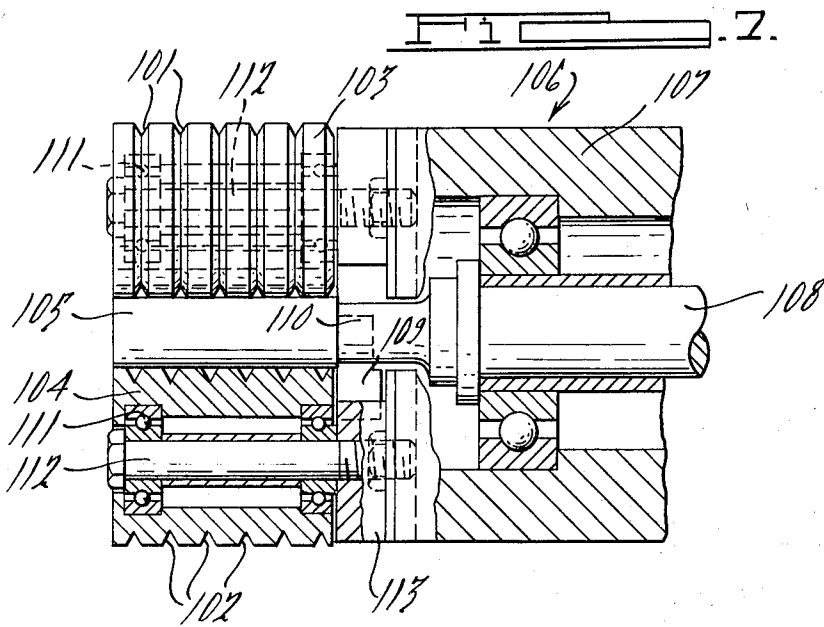

## WIRE COILING TOOL

This application is a continuation-in-part of my co-pending application, Ser. No. 248,747, filed Apr. 28, 1972 now abandoned.

## BACKGROUND OF THE INVENTION

## 1. Field of the Invention

This invention relates to machines for manufacturing wirebound books or pads, and particularly to the mechanism for forming and feeding the spiral wire binder into the punched edge of the book.

## 2. Description of the Prior Art

The previous mandrels and coiling tools were of various types. An early version used a cylindrical mandrel and a pair of grooved cylindrical rollers pressed against it on opposite sides which held the wire against the mandrel as it turned, counteracting the normal spring-back effect of the wire being coiled. This earlier tool was also provided with a stationary hooked-shaped member at the mandrel exit which would act as a brake in case the leading end of the spiral wire hit an obstruction, so as to prevent the wire from being uncontrollably fed out into the air. The coiling tool had many difficult adjustment and control problems and was replaced by a flared mandrel with rows of inwardly extending guide pins. This is exemplified by Mueller U.S. Pat. No. 3,568,728. The flared shape of the mandrel imparted a relatively small radius of curvature to the coil at the beginning of the feed so that it would continue to be driven as it advanced along the mandrel. The presence of the fingers between which the coils passed meant that if the leading end of the coil hit an obstruction it would be permitted to expand and thus automatically be released from the mandrel.

However, this construction also has some disadvantages which it is an object of the present invention to overcome. The flared mandrel creates considerable friction on the wire which is unsatisfactory in some cases, for example, when plastic coated wire is used. The manufacturing tolerances for the flared mandrel are quite small, making it expensive to manufacture. Different coil diameters require different flare angles so that it is necessary to replace the sets of pins as well as the mandrel each time the coil diameter is changed.

## BRIEF SUMMARY OF THE INVENTION

The coiling tool comprises a preforming member adjacent the entrance to the mandrel, the latter being of cylindrical shape. The preforming member will create a radius in the wire smaller than that of the mandrel so that the wire will grip the mandrel tightly throughout its length.

Sets of inwardly extending guides are provided as in the previous coiling tool, but they need not be changed for different diameters of binders, it being only necessary to replace the cylindrical mandrel for one of larger diameter and to move the guides radially outwardly. The result is a tool having relatively low wire friction and which is inexpensive to construct.

The guides in one version of the invention comprise axially spaced pins and in another embodiment axially spaced grooves in rotatably mounted rollers.

## BRIEF DESCRIPTION OF THE DRAWINGS

FIG. 1 is a partly sectioned elevational view of the coiling tool using pins as the guides;

FIG. 2 is an end elevational view of the coiling tool taken in the direction of the arrow 2 of FIG. 1;

FIG. 3 is a sectional plan view taken along the line 3—3 of FIG. 1;

FIG. 4 is a detailed view of the preforming tool;

FIG. 5 is an end elevational view of this tool taken in the direction of the arrow 5 of FIG. 4;

FIG. 6 is another end elevational view taken in the direction of the arrow 6 of FIG. 4; and

FIG. 7 is a fragmentary and partly sectioned elevational view of another embodiment of the coiling tool using grooved rollers as the guides.

## DESCRIPTION OF THE PREFERRED EMBODIMENTS

Referring first to the embodiment of FIGS. 1 to 6, the coiling tool is mounted in housing frame portion 11 of the machine and comprises a cylindrical housing 12 carrying a rotatably mounted shaft 13 supported by bearings 14 and 15 and driven by gear 16. A mandrel generally indicated at 17 is supported by and extends from shaft 13 outwardly of housing 12. The driving portion 18 of mandrel 17 is of cylindrical shape. In practice, different mandrels will be available for various spiral diameters, the mandrels differing in the diameter of portion 18. Two sets of inwardly extending guide pins 19 are mounted adjacent mandrel portion 18. The structure and function of these pins are similar to those disclosed in Mueller U.S. Pat. No. 3,568,728 issued Mar. 9, 1971. The facing pin sets are offset by one-half the wire pitch and have their inner ends closely adjacent the mandrel surface. They act as guides during the coiling process to advance the spiral wire onto the book.

Each set of pins 19 is carried by a pin support 21. These two supports are securable in radially adjusted positions depending on the diameter of mandrel portion 18, and for this purpose are provided with slotted portions 22 receiving clamps 23 which are secured to housing 12.

A preforming tool 24 is held by a clamp 25 secured to housing 12 and is closely adjacent the entrance to mandrel portion 18. The construction of this tool is seen best in FIGS. 4, 5 and 6. The tool is of generally rectangular shape and part of its upper end has an arcuate recess indicated at 26 for clearance of reduced portion 27 of the mandrel. A shoulder 28 extends from one side of the tool and has an outer surface 29 with a radius of curvature which is less than that of the mandrel. This is seen best in FIG. 4. In this figure, 31 indicates the curvature for main portion 18 of the mandrel. The radius of curvature of this surface is indicated by the arrow 32, the center of curvature being at 33. Arrow 34 indicates the radius of curvature of surface 29, its center being at 35. The wire 36 will be fed from a bin through straighteners and around guides (not shown) and will pass downwardly over surface 29. It will be seen in FIG. 4 that when wire 36 passes onto surface 29 it will be spaced radially inwardly from the surface 31 of mandrel portion 18 but will be bent so as to blend onto the mandrel surface as it leaves surface 29, which extends about 90°.

FIG. 6 shows that surface 29 not only bends the wire in a radial direction but is also pitched axially. It thus advances the wire in a longitudinal direction as drawn by mandrel portion 18, onto which the wire is tightly wound, and guide pins 19. The result will be that wire 36 will tend to grip the mandrel from the very beginning of its engagement and this gripping will continue along the entire length of the mandrel even though the latter is not flared.

FIG. 7 shows a modified form of the invention which is basically similar to that of the previous embodiment but in which the guides comprise axially spaced grooves 101 and 102 on rollers 103 and 104 respectively which are rotatably mounted adjacent and on opposite sides of mandrel 105. The coiling tool is generally indicated at 106 and comprises a cylindrical housing 107 carrying a rotatably mounted shaft 108 supporting mandrel 105. The preforming tool shown partially at 109 is similar to tool 24 of the previous embodiment and is positioned as described above with respect to reduced portion 110 and the main portion of mandrel 105.

Rollers 103 and 104 are rotatably mounted by bearings 111 on shafts 112 carried by radially adjustable members 113. As in the previous embodiment, rollers 103 and 104 are securable in positions depending on the diameter of mandrel 105.

In operation of the embodiment of FIG. 7, grooves 101, 102 which are preferably V-shaped as shown, and are offset by one-half the wire pitch, guide the spiral wire advancing along mandrel 105 to create the proper spiral. In the event of an obstruction engaged by the leading end of the coil, the expanding turns will enter more deeply into the grooves, thus being released from the mandrel.

I claim:

1. A coiling tool for forming spiral wire binders comprising a rotating axially fixed mandrel having a cylindrical driving portion, a plurality of sets of inwardly ex-

tending guides surrounding said driving portion of the mandrel, each set being arranged longitudinally of the mandrel, the sets being axially offset with respect to each other so as to guide and advance a spiral wire being driven by the mandrel, and preforming means engageable with said wire in advance of said driving portion and so changing the shape of said wire as to cause it to tightly grip the driving portion from the beginning of its engagement therewith, said preforming means comprising a tool adjacent the entrance end of said cylindrical mandrel portion, said preforming tool having a concave arcuate surface with a radius of curvature smaller than that of the cylindrical mandrel portion, the portion of said arcuate surface initially engaged by the wire being spaced radially inwardly from the mandrel surface, the exit of the arcuate surface being so shaped that the wire will be bent so as to blend onto the mandrel surface as it leaves the arcuate surface.

2. The combination according to claim 1, said preforming tool being of generally rectangular shape, said surface being on a shoulder projecting outwardly from one side of the preforming tool, the tool having a relieved portion within which a portion of said mandrel fits.

3. The combination according to claim 2, said surface also being pitched axially so as to longitudinally advance the wire.

4. The combination according to claim 1, said guides comprising axially spaced pins.

5. The combination according to claim 1, said guides comprising axially spaced grooves in rollers rotatably mounted adjacent the mandrel.

6. The combination according to claim 5, there being two rollers on opposite sides of said mandrel, and means for radially adjusting said rollers with respect to the mandrel.

7. The combination according to claim 6, said grooves being V-shaped.

\* \* \* \* \*

40

45

50

55

60

65