



(12) **United States Design Patent**
Powell et al.

(10) **Patent No.:** **US D872,355 S**
(45) **Date of Patent:** **** Jan. 7, 2020**

(54) **AEROSOL GENERATOR BODY**

FOREIGN PATENT DOCUMENTS

(71) Applicant: **British American Tobacco (Investments) Limited**, London (GB)

AU 201710494 4/2017
CN 203162984 U 8/2013

(Continued)

(72) Inventors: **David Hillary Powell**, London (GB);
Matthew Peter Tidnam, London (GB);
Neil Martin Baron, London (GB);
Rowan Stephen Williams, London (GB)

OTHER PUBLICATIONS

Design U.S. Appl. No. 29/633,974, filed Jan. 17, 2018. Inventors: Powell et al., 118 pages.

(Continued)

(73) Assignee: **BRITISH AMERICAN TOBACCO (INVESTMENTS) LIMITED**, London (GB)

Primary Examiner — Susan Bennett Hattan

Assistant Examiner — Rebecca Tsehaye

(74) *Attorney, Agent, or Firm* — Patterson Thunte Pedersen, P.A.

(**) Term: **15 Years**

(21) Appl. No.: **29/645,152**

(57) **CLAIM**

We claim the ornamental design for an aerosol generator body, as shown and described.

(22) Filed: **Apr. 24, 2018**

(30) **Foreign Application Priority Data**

DESCRIPTION

Oct. 24, 2017 (EM) 004419653

(51) **LOC (12) Cl.** **27-05**

(52) **U.S. Cl.**

USPC **D27/141**

(58) **Field of Classification Search**

USPC D27/141, 101, 106, 108, 142, 144, 163,
D27/165, 167-169, 172, 174, 175, 183,
D27/186-190, 193, 195; D24/110;
131/273, 274, 191, 329, 330

CPC A24F 9/00; A24F 47/002; A24F 47/004;
A24F 47/006; A24F 47/008; A61M 15/06

See application file for complete search history.

FIG. 1 is a front top perspective view of an aerosol generator body.

FIG. 2 is a rear bottom perspective view of the aerosol generator body depicted in FIG. 1.

FIG. 3 is a front elevational view of the aerosol generator body depicted in FIG. 1.

FIG. 4 is a rear elevational view of the aerosol generator body depicted in FIG. 1.

FIG. 5 is a left side elevational view of the aerosol generator body depicted in FIG. 1, the right side elevational view being a mirror image thereof.

FIG. 6 is a top plan view of the aerosol generator body depicted in FIG. 1; and,

FIG. 7 is a bottom plan view of the aerosol generator body depicted in FIG. 1.

The broken lines in the drawings depict portions of the aerosol generator that form no part of the claimed design.

(56) **References Cited**

U.S. PATENT DOCUMENTS

D201,420 S 6/1965 Bernard
D365,889 S 1/1996 Kim
D418,253 S 12/1999 Bakic

(Continued)

1 Claim, 7 Drawing Sheets

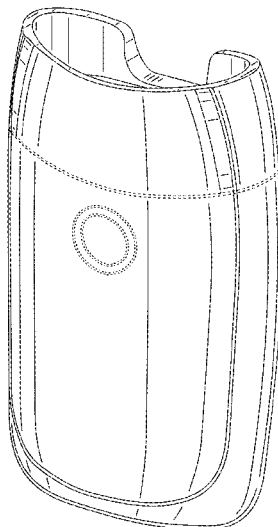

(56)

References Cited

U.S. PATENT DOCUMENTS

D421,300 S 2/2000 Denyer et al.
 D426,030 S 5/2000 Heeter et al.
 D447,948 S 9/2001 Pannozzo et al.
 D463,618 S * 9/2002 Smith D27/157
 D473,796 S 4/2003 Calello et al.
 D485,639 S 1/2004 Stronski
 D493,912 S * 8/2004 Wong D27/141
 D502,285 S * 2/2005 Tufts, Jr. D27/141
 D532,927 S 11/2006 Sann
 D536,969 S 2/2007 Geier
 D546,939 S 7/2007 Collins et al.
 D561,891 S 2/2008 Lithgow et al.
 D579,342 S * 10/2008 Claughton D9/688
 D580,776 S * 11/2008 Claughton D9/688
 D612,480 S 3/2010 Cork et al.
 D613,395 S 4/2010 Nakao et al.
 D613,396 S 4/2010 Nakao et al.
 D614,285 S 4/2010 Birath et al.
 D627,638 S * 11/2010 Bodet D9/448
 D634,065 S 3/2011 Borushek et al.
 D641,409 S 7/2011 Wang et al.
 D644,375 S 8/2011 Zhou
 D673,325 S 12/2012 Marines
 D676,621 S 2/2013 Florkiewicz et al.
 D680,432 S 4/2013 Geier
 8,499,766 B1 8/2013 Newton
 D690,383 S 9/2013 Sheikh et al.
 D691,324 S 10/2013 Saliman
 D696,455 S 12/2013 Abroff
 D707,484 S 6/2014 Fee
 D711,528 S 8/2014 Grunstad et al.
 D718,492 S 11/2014 Albanese
 D720,499 S 12/2014 Alima
 D720,882 S 1/2015 Albanese
 D720,883 S 1/2015 Albanese
 D723,216 S 2/2015 Chen
 D725,310 S 3/2015 Ekosuzian
 D728,855 S 5/2015 Liu
 D729,366 S * 5/2015 Kauss D23/360
 D736,994 S 8/2015 Miuttersinker
 D741,178 S 10/2015 Higareda et al.
 D741,179 S 10/2015 Higareda et al.
 D743,622 S 11/2015 Alima
 D746,680 S 1/2016 Orasche et al.
 D748,853 S 2/2016 Seibel et al.
 D750,492 S 3/2016 Campbell et al.
 D750,834 S 3/2016 Wei
 D750,835 S 3/2016 Wei
 D752,278 S 3/2016 Verleur
 D753,874 S 4/2016 Moreno
 D756,031 S 5/2016 Wu
 D757,352 S 5/2016 Bagai
 D758,656 S 6/2016 Freshwater et al.
 D760,948 S 7/2016 Eksouzian
 D761,998 S 7/2016 Pinder
 D763,501 S 8/2016 McGarry et al.
 D763,502 S 8/2016 Verleur et al.
 D764,701 S 8/2016 Malhi
 D768,915 S 10/2016 Wright et al.
 D771,867 S 11/2016 Leidel et al.
 D773,727 S 12/2016 Eksouzian
 D776,337 S 1/2017 Levin et al.
 D776,869 S 1/2017 Heidl
 D778,493 S 2/2017 Scott
 D778,494 S * 2/2017 Scott D27/189
 D779,719 S 2/2017 Qiu
 D780,991 S 3/2017 Liu
 D782,728 S 3/2017 Pinder
 D782,729 S 3/2017 Wright et al.
 D786,497 S 5/2017 Sudlow et al.
 D787,114 S 5/2017 Scott
 D790,123 S 6/2017 Beer et al.
 D790,124 S 6/2017 Beer et al.
 D790,125 S 6/2017 Beer et al.
 D792,021 S 7/2017 Beer et al.

D792,643 S 7/2017 Wong et al.
 D795,496 S 8/2017 Beer et al.
 D799,110 S 10/2017 Qiu
 D799,112 S 10/2017 Qiu
 D799,113 S 10/2017 Qiu
 D799,745 S 10/2017 Qiu
 D800,383 S 10/2017 Verleur et al.
 D801,581 S * 10/2017 Scott D27/189
 D802,208 S * 11/2017 Scott D27/189
 D802,839 S 11/2017 Scott
 D804,091 S 11/2017 Fornarelli
 D805,684 S 12/2017 Thuery
 D807,576 S 1/2018 Liu et al.
 D814,303 S 4/2018 Ascherl et al.
 D818,638 S 5/2018 Wright et al.
 D819,880 S 6/2018 Qiu
 D820,515 S 6/2018 Nettenstrom et al.
 D823,536 S * 7/2018 Lai D27/163
 D825,099 S 8/2018 Wright et al.
 D825,103 S 8/2018 Wright et al.
 D827,117 S * 8/2018 Rigbi D23/360
 D831,270 S 10/2018 Qiu
 D831,271 S 10/2018 Qiu
 D832,501 S 10/2018 Qiu et al.
 D843,052 S * 3/2019 Powell D27/163
 2008/0164285 A1 7/2008 Hygema
 2010/0200008 A1 8/2010 Taieb
 2013/0042865 A1 2/2013 Monsees et al.
 2013/0152954 A1 6/2013 Youn
 2013/0199528 A1 8/2013 Goodman et al.
 2014/0026903 A1 1/2014 Haider
 2014/0283858 A1 9/2014 Liu
 2015/0034104 A1 2/2015 Zhou
 2015/0059786 A1 3/2015 Lie et al.
 2015/0101623 A1 4/2015 Liu
 2015/0114406 A1 4/2015 Newton
 2015/0128971 A1 5/2015 Verleur et al.
 2015/0150307 A1 6/2015 Liu
 2015/0164141 A1 6/2015 Newton
 2015/0181930 A1 7/2015 Liu
 2015/0181940 A1 7/2015 Liu
 2015/0196055 A1 7/2015 Liu
 2015/0208728 A1 7/2015 Lord
 2015/0333542 A1 11/2015 Alarcon et al.
 2015/0335075 A1 11/2015 Minskoff et al.
 2015/0342255 A1 12/2015 Wu
 2016/0050976 A1 2/2016 Righetti
 2016/0113325 A1 4/2016 Liu
 2016/0150823 A1 6/2016 Liu
 2016/0204637 A1 7/2016 Alarcon et al.
 2016/0213065 A1 7/2016 Wensley et al.
 2016/0270441 A1 9/2016 Lewis et al.
 2016/0270446 A1 9/2016 Shenkal et al.
 2016/0278163 A1 9/2016 Chen
 2016/0278436 A1 9/2016 Verleur et al.
 2016/0286864 A1 10/2016 Lin
 2016/0366941 A1 12/2016 Lin
 2017/0035117 A1 2/2017 Lin
 2019/0083720 A1 3/2019 Leadley et al.

FOREIGN PATENT DOCUMENTS

CN 302876551 7/2014
 CN 303115457 S 2/2015
 CN 104432543 A 3/2015
 CN 303879350 S 10/2016
 EM 001279020-0001 7/2011
 EM 001316533-0003 3/2012
 EM 001307631-0024 4/2012
 EM 003346022-0012 8/2016
 JP 1519006 S 3/2015
 JP 1519007 S 3/2015
 JP 1561415 S 10/2016
 JP 1563215 S 11/2016
 JP 1563216 S 11/2016
 KR 3006818400000 2/2013
 KR 3006818400001 5/2013
 KR 3006818400002 5/2013

(56)

References Cited

FOREIGN PATENT DOCUMENTS

KR	3007215630000	12/2013
RU	96946 S	1/2016
WO	WODM081209	6/2013

OTHER PUBLICATIONS

Design U.S. Appl. No. 29/633,976, filed Jan. 17, 2018. Inventors: Powell et al., 95 pages.

Design U.S. Appl. No. 29/645,149, filed Apr. 24, 2018. Inventors: Powell et al., 73 pages.

Design U.S. Appl. No. 29/645,154, filed Apr. 24, 2018. Inventors: Powell et al., 74 pages.

Design U.S. Appl. No. 29/645,155, filed Apr. 24, 2018. Inventors: Power et al., 75 pages.

Decision to Grant in Russian Application No. 2018500239/49, dated Jul. 6, 2018, 4 pages.

Decision to Grant in Russian Application No. 2018500240/49, dated Jul. 6, 2018, 4 pages.

Notice of Allowance in Japanese Application No. 2018-000974, dated Apr. 3, 2018, 4 pages.

Notice of Allowance in Japanese Application No. 2018-000975, dated Apr. 3, 2018, 4 pages.

Decision to Grant in Russian Application No. 2018501855/49, dated Apr. 23, 2018, 6 pages.

Decision to Grant in Russian Application No. 2018501856/49 dated Apr. 23, 2018, 6 pages.

Decision to Grant in Russian Application No. 2018501854/49 dated Mar. 1, 2019, 10 pages.

Decision to Grant in Russian Application No. 2018501853/49 dated Mar. 1, 2019, 10 pages.

* cited by examiner

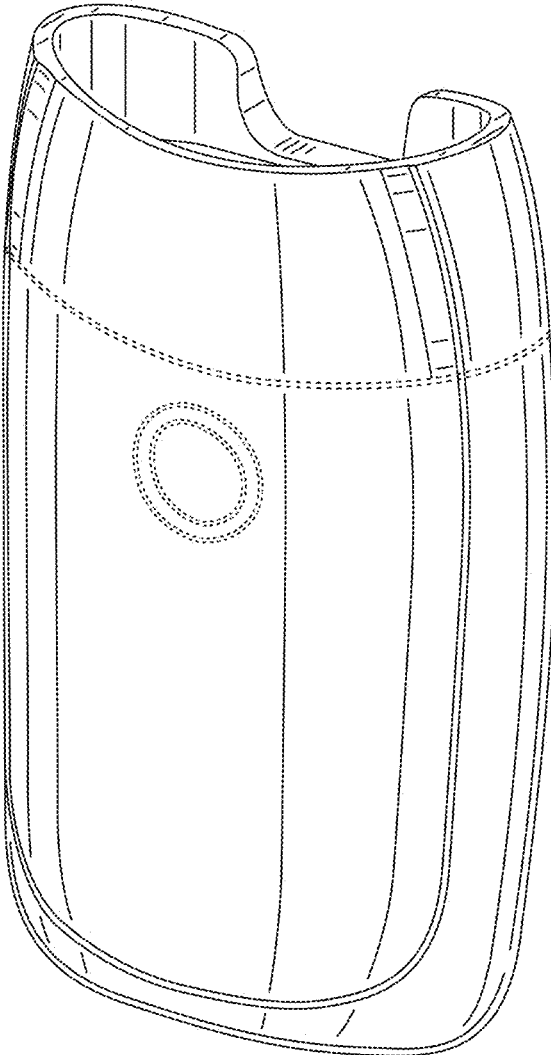

FIG. 1

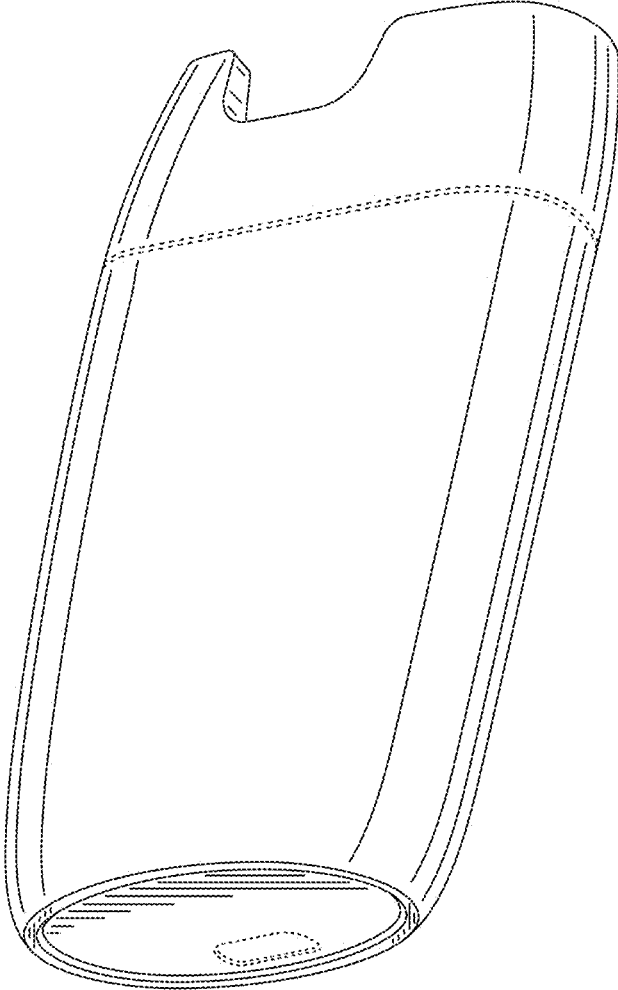

FIG. 2

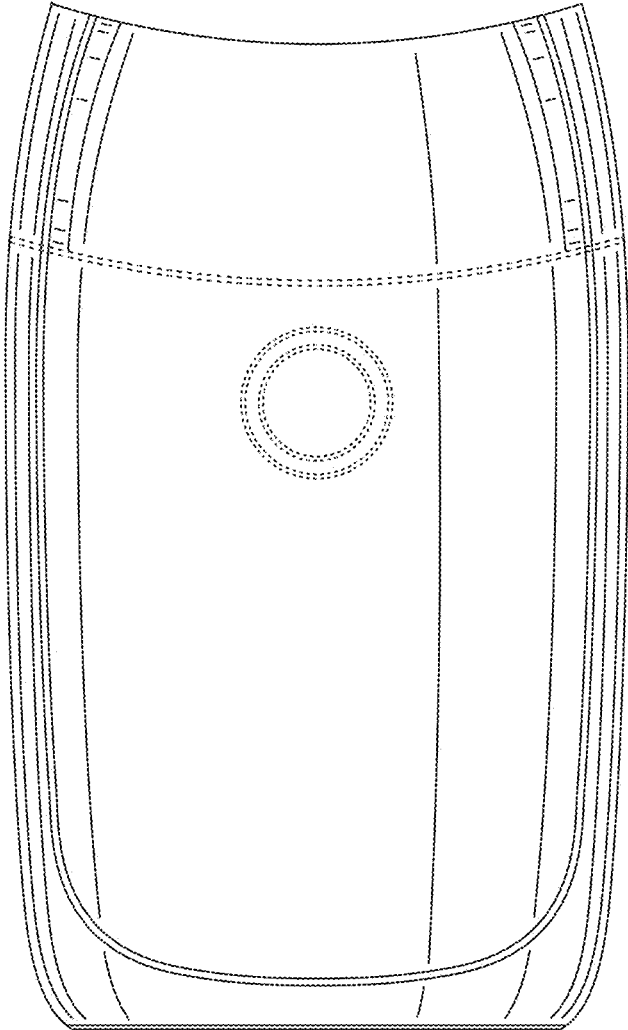

FIG. 3

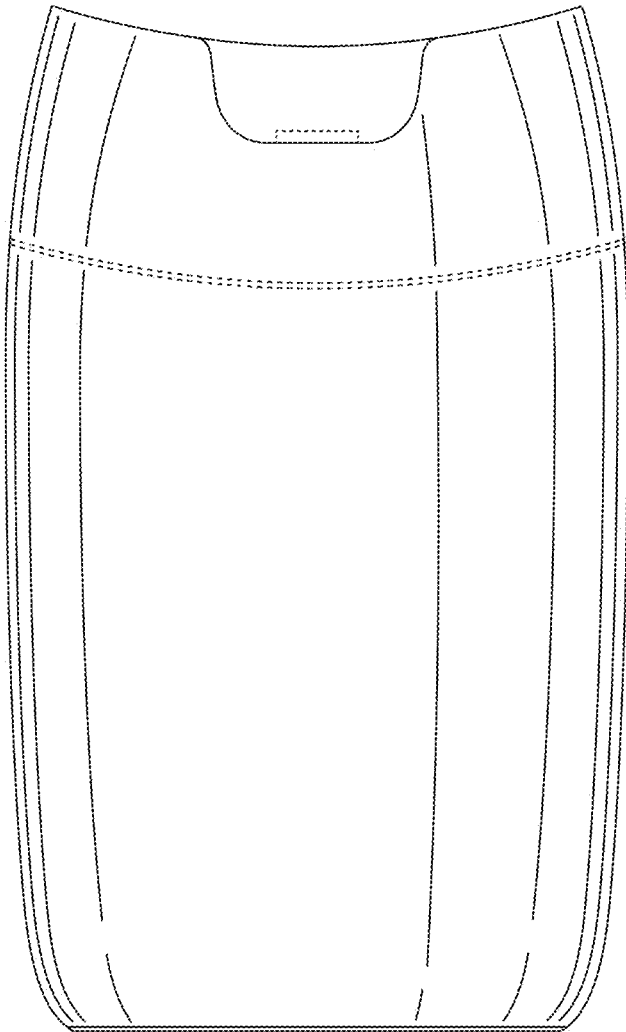

FIG. 4

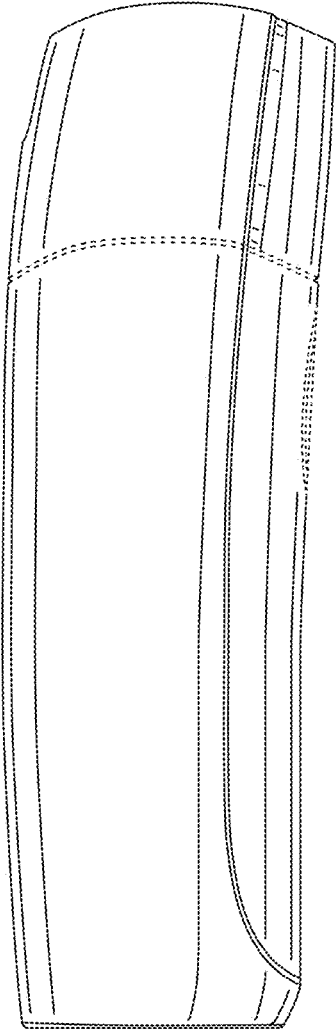

FIG. 5

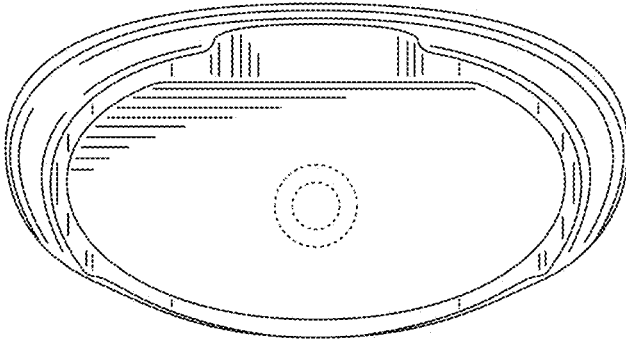

FIG. 6

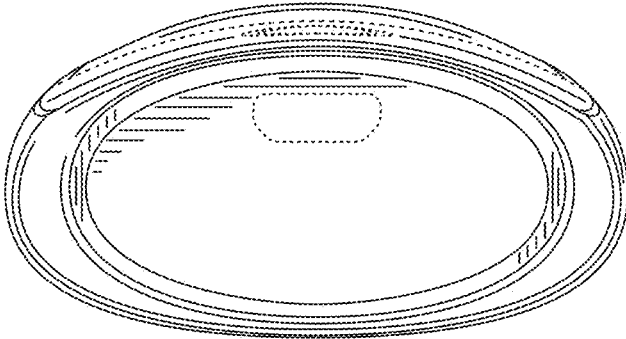

FIG. 7