

(19)  
(12)

(KR)  
(B1)

(51) 。 Int. Cl. <sup>7</sup>  
F16H 61/06

(45)  
(11)  
(24)

2002 10 18  
10 - 0357593  
2002 10 08

(21) 10 - 2000 - 0056134  
(22) 2000 09 25

(65)  
(43)

2002 - 0024399  
2002 03 30

(73) 231

(72) 1 - 1  
1 - 1  
211 303  
1 - 1  
1 - 1  
1 - 1

(74)  
:

(54)

2 가

가

, N - R

3

, , ,

1

.

2

.

3

(N)

4

.

5

,

, N - R

6

.

7

(P)

8

(D)

1

9

(D)

2

10

(D)

3

11

(D)

4

12

L

13

(R)

,

,

,

.

가  
 3  
 2 4  
 /  
 가 가

가  
 2  
 가  
 가

, N - R  
 2  
 1,2,3 1,2,3  
 1,2,3

1 2 1  
 , 3 2 2  
 2 2 ,  
 1 1 2 4  
 2 ,  
 N - R N - R  
 ,  
 2, 3 L , 2 2, 3 , 2 2 , 3 N -  
 R ,  
 1 , 2 4 1  
 , (2) (4) (6) , (6) 1, 2  
 (8)(10) 1, 2 (8)(10)  
 1 (8) (12)  
 (14) .  
 ( 1, 2 (8)(10)가 1 (16), (12), (18) 1 (16), 1 (12), 1 (18)  
 , 2 (20), (22), (24) 2 (20), 2  
 (22), 2 (24) .)  
 1,2 (8)(10) 1 (12) 2 (24)  
 (6) 1 (16) 1 (C1)  
 2 (22) 3, 4 2 (C2) (6) , 2  
 (20) 3 (C3) (6) .  
 , 2 (22) 1 (B1) 1 (F1)  
 (26) 1 (18) 4 (C4) 2 (F2)  
 2 (20) 2 (B2) (26) .  
 1,2 (F1)(F2)가 , 1 (16)가 1 (C1) 4 (C4)  
 (22)가 , 1 (18) 2

2 1 2 (B2)가 , 1 (18)  
 2 (20)가 .

3 2 2 (C2)가 , 2 (B2) , 1,  
 2 (8)(10)가 .

4 3 2 (B2)가 가 2 (20)가  
 4 .

2 3,4 (C3)(C4) 1 (B1)가 2 (20)  
 2 (22)가 가 .

3 (C1)(C2)(C3)(C4)(B1)(B2)  
 , 가 (N) ,

(2) (4)가 , (100)  
 가 (100) (4) ,

N - R ,

2 (100)  
 .

(102) , (102) (100)  
 (104) ,  
 (106) .

(108) (106) (108) ,  
 (102) .

14) , 1,2,3 (S1)(S2)(S3) 1,2,3 (110)(112)(1  
 .

(116) , (116)  
 1, 2 (122)(124), N - R N - R 1, 2 (126) (1  
 18)(120),

(501) 4 (C4) , 2, 3 , 2 (116) 2 , 3 2, 3 L 3 , 2 (120)  
 3 (C3) (500) N-R (126) (C3)

N (116) (130), D (102) (128), L (118) 4 (126) (132), "R" (134)

N (130) 1 (110) 2 (124)  
 , D (128) 2,3 (112)(114)  
 1,2 (118)(120) , L (132) 1  
 (118) , "R" (134) N-D (126)  
 (102)

(118) 1 (110) 1 (S1) , 4  
 , 1 (110) (108) 1 (150)  
 (116) 2 (152) , 2 (152) 1  
 (154) , 1 (S1) 4 (156)

1 (158) , 1 (150) 1 (150)  
 2 (160) , 2 (160) 2 (152) 3 (154) (152)  
 (162) , 3 (162) (164)가 3

1 (110) 1 (S1) 3  
 1 (110)

(150) 1 (S1)가 4 (156) , 1  
 (152) , 1 (110) 2  
 2 (152) 3 가 (156) 4 (156)  
 (154) 1 (120)

2 (112) (108) 1 (170) ,  
 (116) 2 (172) , 2 (172) 2  
 (124) 3 (174) , 2 (S2) 4 (176)

1 (170) ,  
 1 (178) , 1 (170) 2 (172) 3 (174) 3  
 2 (180) , 2 (182) 2 (172) 3 (184)가  
 (182) , 3 (182)

(170) 2 (S2)가 4 (176) , 1  
 (172) , 2 (112) 2  
 2 (172) 3 (174) 4 (176) 2 (124)  
 가

, 3 (114) (108) 1 (190) ,  
 (116) 3 2 (192) , 2 (192) 2 (114)  
 3 (194) , 3 (S3) 4 (196)

1 (190) ,  
 1 (198) , 1 (190) 2 (192) 3 (194) 3  
 2 (200) , 2 (200) 3 (202) 3 (204)가  
 (202)

2 3 (S3)가 3 (114)  
 (192) , 3 가  
 2 (192) 3 (194) (114)  
 (120)

5 (116) (108)  
 / / (S4)  
 1, 2 (118)(120)

C2) 1 (118) 1 (110) N 2 ( )  
 1 (122) 1 (B1)

1 (118) (116) (116) N  
 1 (210) , (116) L 2 (212) , /  
 (S4) 3 (214) , 1 (110) 4  
 (216) , 4 (216) 2 (C2) 1, 2 (122)(124)  
 5 (218) , 4 (216) 1 (122) 6  
 (220) , 5 (218) 6 (220) 1, 2 (EX1)(EX2)

, 1,2,3 (210)(212)(214)  
 1 (210) 1 (222) , 4 (218) 6 (220)  
 2 (224) , 4 (218) 5 (218) 3 (226) ,  
 3 4 (228) , 2 (212)  
 5 (229)

, 1,2,3,4 1 (210) 3, 4 1  
 (110) 2 (C2) , L 2 (212) 3 (214)  
 1 (110) 1 (B1)  
 , 2 (C2) 1 (B1)

2 (120) (116) D 1 (  
 230) , / (S4) 2 (232) , 3 (114)  
 3 (234) , 4 (236) , 3 (234) 1  
 (C1) 5 (238) , 1 (230) 1 (C1) 6 (  
 240) , 4 (236) 4 (C4) 7 (242) , 3 (234)  
 4 (C4) 8 (244) , 5,6,7,8 (238)(240)(242)(244)  
 1,2 (EX1)(EX2)

, 1,2 (230)(232) 1  
 (230) 1 (230) 6 (240) 1,2  
 (246)(248) , 3 (234) 5 (238) 3 (250) , 3  
 (234) 8 (244) 4 (252) , 4 (236) 7 (242)  
 5 (254) , 2 (232) 6 (256)

5 (238) 6 (240) 1 (260) 1 (C1)  
 , 1 (260) 가 1 (230)  
 (262) 1 (264) , 1 (264)

, 1 (230) (262) 2 (266) 1,2  
 (122)(124) 1 (B1) , 2 (266)

, 7 (242) 8 (244) 2 (268) 4 (C4)  
 , 2 (268) 가 2 (124)

1,2 (264)(266) D N  
 , 1,2 (260)(268) 2 (120) 1, 4 (C1)(C4)



R (C4) / 2 (120) 2,3 3 (114) 4 , N,P,  
 / / (116) D 1 (C1) , L  
 4) / (S4) (S4) 4 (C4) , L (C  
 1 (114) (116) D 4 (C1) .

가 1,2 (122)(124) 1,2 (B1)(B2)  
 , 1 (122) , 5 ,  
 2 (C2) 1 (280) , 2 (B2)  
 30) 1 (118) 2 (282) , 3 (284) , R (1  
 4 (288) 3 (C3) 5 (286) 4 (288) ,  
 5 (290) .

96) , 1 (280) 1 (292) , 2 (282)  
 2 (294) , 4 (288) 5 (290) 3 (2  
 3 (296) 4 (288) 5 (290) 4 (298) ,  
 3 (284) 5 (300) .

1) , N,P,L 1 (118) 1 (B  
 , R R (130) 1 (B1) .

4) 2 (124) R 1 (310) , 4 (C  
 가 2 (312) , 2 (C2) 가  
 3 (314) , N 4 (316) , 2 (112)  
 5 (318) , 5 (318) 2 (B2) 6 (3  
 20) .

5 (318) 6 (320) 1 (310) 1 (322) , 2 (312)  
 2 (324) , 3 (314) 3 (326) ,  
 318) 6 (320) 5 (330) , 4 (328) , 4 (328) 5 (  
 (332) 4 (316) 6 .

2 4 2 (112) 2 (B2) .

N - R 1 (340) , R N - R (126) 5 , 2 (S2)  
 3 (C3) 3 (344) 가 2 (342) , 2 (342)  
 3 (346) R (134) 3 (344) , 3 (344)  
 3 (346) 3 (C3)

, 2,3 (340)(342) 1 (340) 2 (350) 1 (348) ; 2 (252) (352)가 .

, N - R (116) (126) R 2 (S24) 3 (C3)

, (102) 가 , 3 (108) 가가 (S5) 가 (S5) 가 (100)

N - R (511) , (C3) (126) 1 (503) , 3 (507) , 2 (509) , 2 (507) (120) 3 (509) , 2 (513) , 5 (511) (515) D 4 (509) , 2 (511) R 2 (505) , 3 (511)

2 (505) 1 (503) 2 (519) , 1 (517) , 3 (521) , 3 (521) 4 (509) 5 (511) 4 (523) , 6 (513) 5 (511) 5 (525)

, (501) 2,3 L 2 (505) 6 (513) 2 (120) 4 (C4) 5 (511) 4 (509) 3 (C3) (500)

(N), (P) (R) 1 (503) 2 (505) 3 (507) 4 (509) , N - R (126) 3 (C3) (500)

, 3 (N) (100) (102) (108) (106) 1, 2, 3 (110)(112)(114) (116) N (130) 1,2,3 (110)(112)(114) 2 (124) 2 (120) 1 (122)

, 2,3 (S2)(S3)가 1 (S1) / (S4)가  
 , 4 (C4) 1 (B1)가  
 (P) 7 (N) (116)  
 4 (C4) 1 (B1)가

(130) (N) (P) (116) N  
 (509) (R) , N-R (126) (501) 2 (505))  
 3 (C3) 3 (C3) 3 (507) 4  
 (500)

(D) 1 , 8 , 1 (S1)가  
 , 3 (S3)가  
 , 1 (B1) , 3 (114) 3  
 1) (C4)가 (S4) 1 2 (120) 1 (C1) , 1,4 (C  
 = , 1 = 1 (B1)가 , 3 , = 0,  
 , 1 (C1) , 1 (B1)

1 가 가 2  
 , 9 (S2) , / 1 (S4) 2  
 / (S4) 2 (120)  
 , 1 (C1) 2 (120) D (128)  
 , 4 (C4) 3 (114) 2 (120)

, 2 (112) 2 (124) 2 (B2)  
 , 1,4 (C1)(C4)가 , 2 (B2)가 2

10 2 가 가 , 3  
 2 (S2) 1 (S1) ,

2 (112) , 2 (B2) , 1  
 (110) 1 (118) 2 (C2) 3

11 3 , 2 가 (S2) 가 가 , 3  
(S3) .

3 (114) 4 (C4) 4 (C4)  
(C2) , 2 (S2) 1 (122) 2  
, 1,3 (C1)(C3) 2 (B2)가 4 .

L 1 1 , 12 , 1 (S1)가  
2 (112) 1 (118) 1 (122) 1 ( )  
B1) , 1,4 (C1)(C4) 1 (B1) .

, (D) , 1,2,3,4 L (116) N, D  
(130,128) , 1 2, 4 3, (501) 2 (505)) 6 (513)  
(120) 4 (C4) , 5 (511) 4 (509) 3 (C3)  
(500) .

13 (R) , 1 (S1) 2,3  
(S2)(S3) / (S4)가 .

, (126) 2 (120) 4 (C4) , /  
(S4) N - R (126)가 R (134)  
3 (C3) .

1 N R 가 1 (B1) 1 (B1)  
(B1) 2 .

, 2  
가 ,  
가 ,  
, 2  
, 가 ,  
, 가 ,  
, 가 ,  
, N R, N D  
가 가 가

(57)

1.

, , , N - R

2

1,2,3 , 1,2,3

1,2,3

1 2 2 1

2 , 3 2

2 1 1 2 4

N - R N - R

2, 3 L , 2 2, 3 , 2 2 , 3 N -

R

2.

1 ,

3.

1 ,

N, D , D , L 1 1 , N, D 2 1 , 3 2 2

D , L 1 1 L , R

2 N-R "R" 가

4.

1 , 1, 2, 3

3

5.

1 , 1

1 ; 2 ; 2  
3 ; 1 4

1 , 1 ; 1  
2 ; 2 3  
3 , 3 가 2 3

6.

1 , 2

1 ; 2 ; 2  
2 ; 3 ; 2 4

1 , 1 ; 1  
2 ; 2 3  
3 , 3 가 2 3

7.

1 , 3

1 ; 2 ; 2  
3 ; 3 4

1 , 1 ; 1  
2 ; 2 3  
3 , 3 가 2 3

8.

1 , 1

1 N, D 2 1 1

9.

1 , 1

N, D

1

L

2 , /

3

1

4 , 4

2

1, 2

6

5

6

5 , 4 1,2

1

;

6

5

6

1 , 1

1

4

6

2

, 4 5

3

,

3

4

2

5

10.

1 9 , 1

1,2,3,4 1

2

, L

2

3

3, 4

1

1

1

2

1

11.

1 , 2

2,3,4

3

4

D

1

, N,P,R

/

D

4

, L

/

1

4

1

12.

1 , 2

D

1

, /

2

3

3

,

4

,

3

,

1 5 , 1 1 6 , 4  
4 7 , 3 4 8  
, 5,6,7,8 1,2 ;

1 1 6 1,2 ,  
3 5 3 3 8  
4 , 4 7 5 , 2  
6 .

13.

12 , 2 5 6  
1 1 , 1 가 1  
1

14.

13 , 2 1  
2 1,2 1

15.

12 , 2  
7 8 2 4 , 2  
가 2

16.

1 , 1  
N,P,L 1 1 , R  
R 1

17.

1 , 1  
2 1 , 2  
2 , 3 , R 1  
3 4 , 4 3 5  
;



1 1 , 2 2 ,  
 4 4 5 , 3 3 5 4 5

18.

1 , 2  
 2 4 2 2

19.

1 , 2

R 1 , 4 가 2 ,  
 2 가 5 , 5 , N 4 ,  
 2 5 2 6

1 1 , 2 2 ,  
 3 3 , 5 6 4 ,  
 , 4 5 6 5 , 6 4

20.

1 , N-R

R 2  
 3

21.

1 , N-R

2 1 , R 2 , 2  
 3 3 ;

1 ; 2,3 2  
 , 2 가

22.

21 , N-R

3

3 R

23.

1 ,  
 N - R R 3 2 D  
 4, 3 ,

24.

1 ,  
 R 1 , N  
 2 , N - R 3 , 4 , D  
 4 , 2 5 , ;  
 6 , 5  
 1 1 2 2  
 3 4 3 4 5  
 5 , 5 4 3 6  
 5

25.

1 24 ,  
 2, 3 2, 3 L 2 6 ,  
 2, 3 , 2 2 , 3 2, 3 L , 2 4 ,  
 5 4 , ,  
 1 2 N - R 3  
 3 4

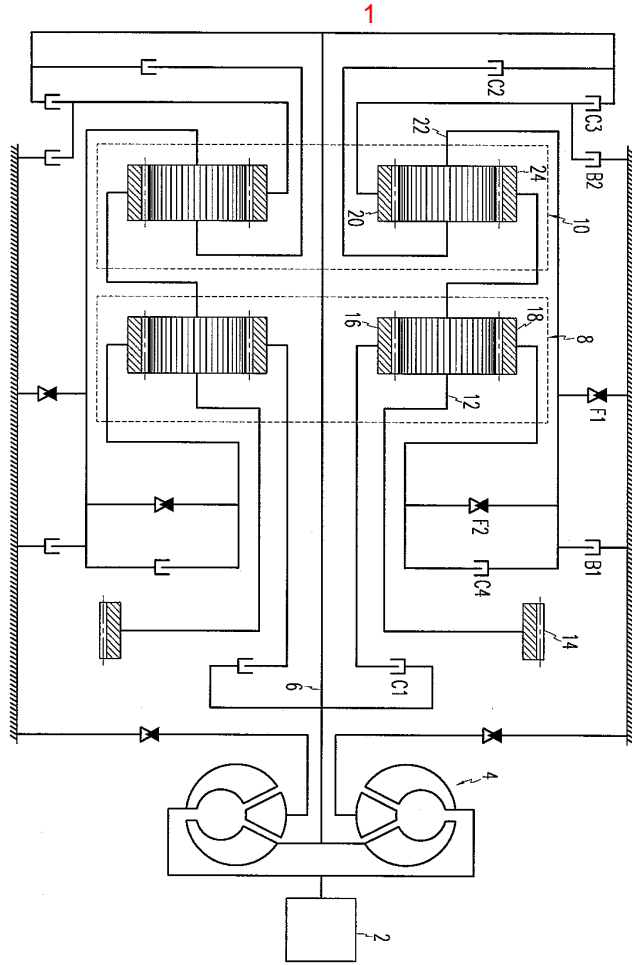

2

별속단	영수							
	C1	C2	C3	C4	B1	B2	F1	F2
N,P				○	○			
1속	○			○			○	○
2속	○			○		○		○
3속	○	○		○				○
.4속	○	○				○		
Rev			○	○	○			
Low	○			○	○			

3

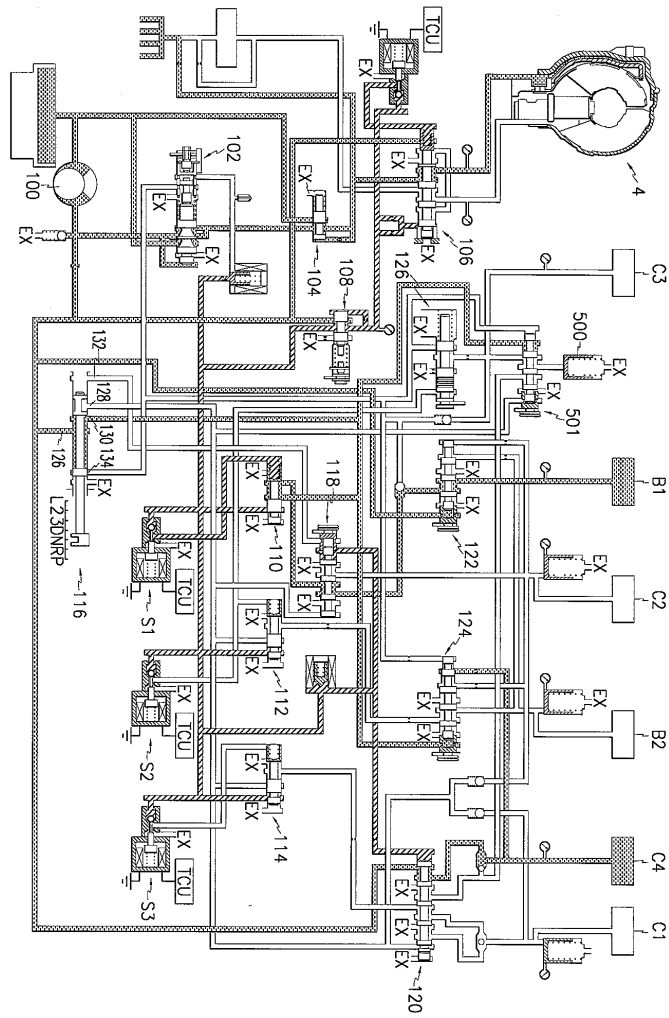

4

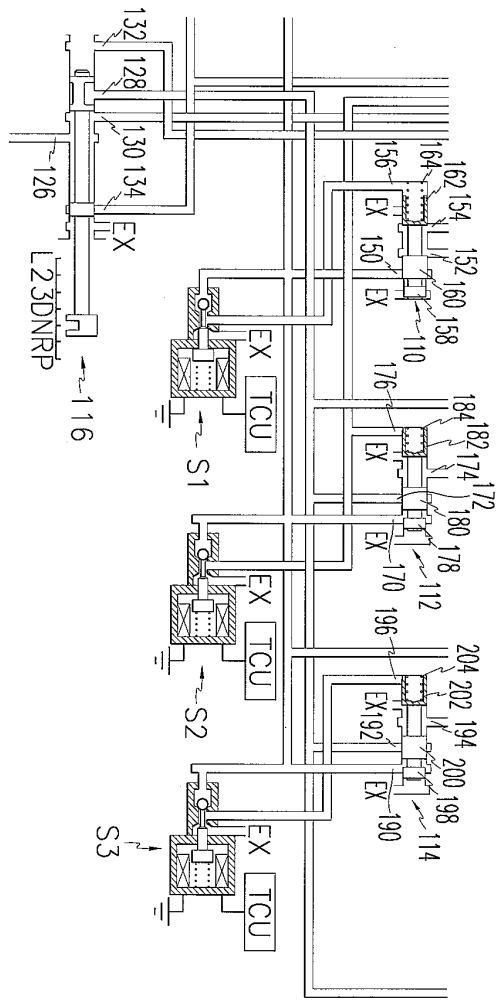

5

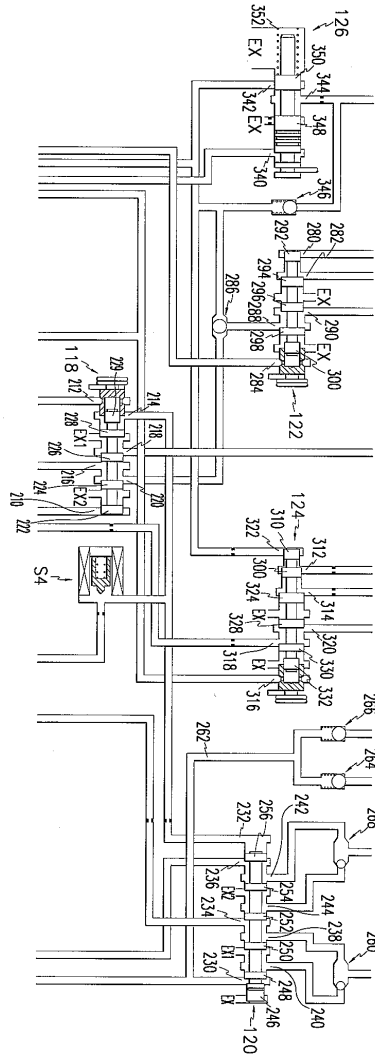

6

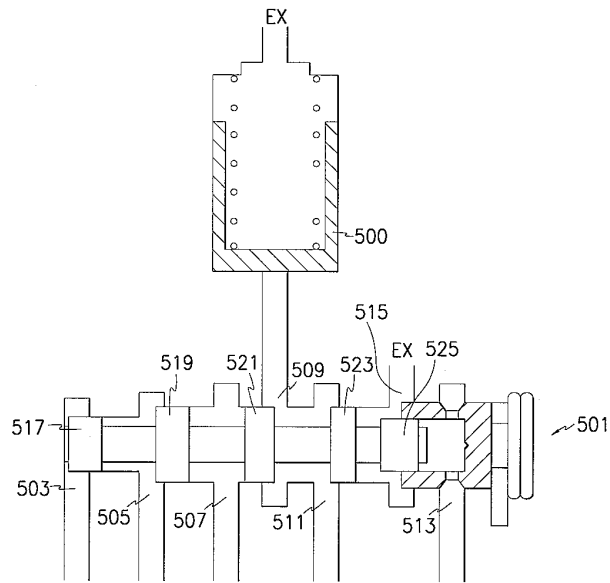



7

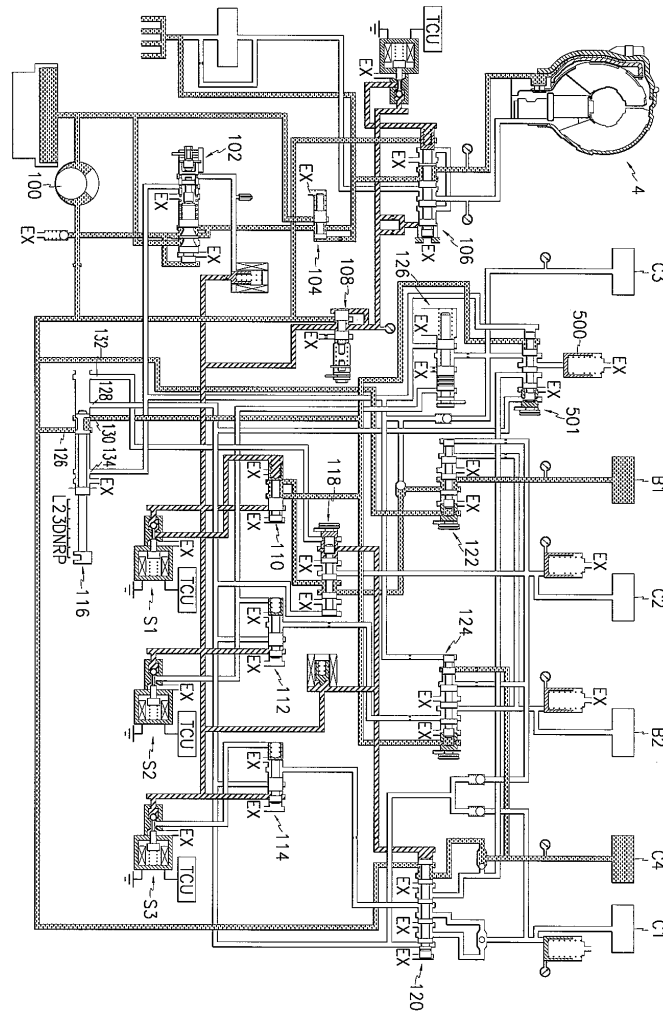

8

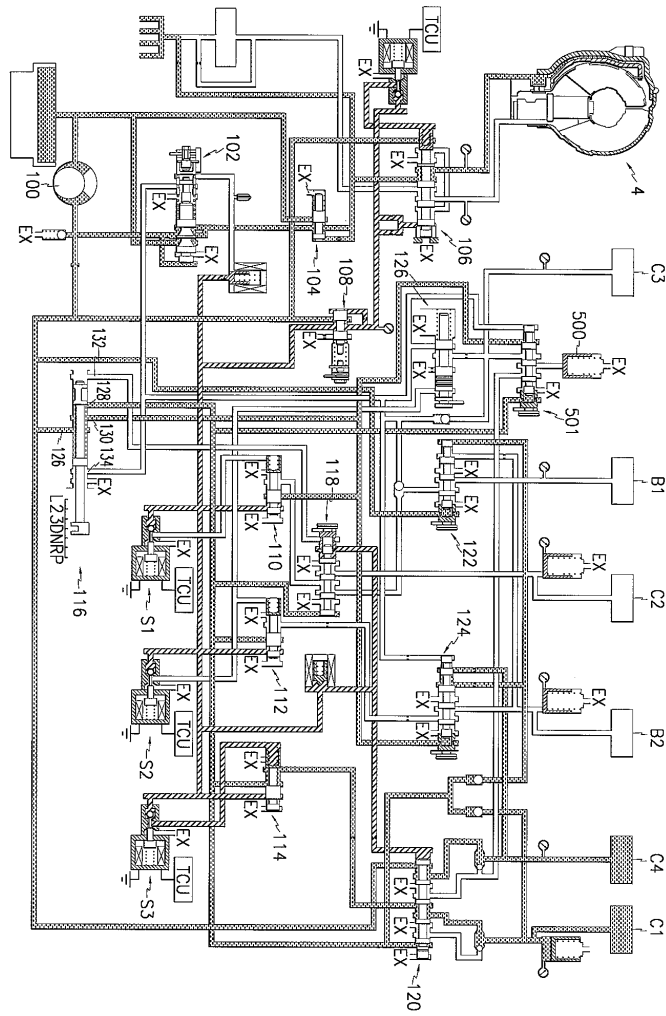

6

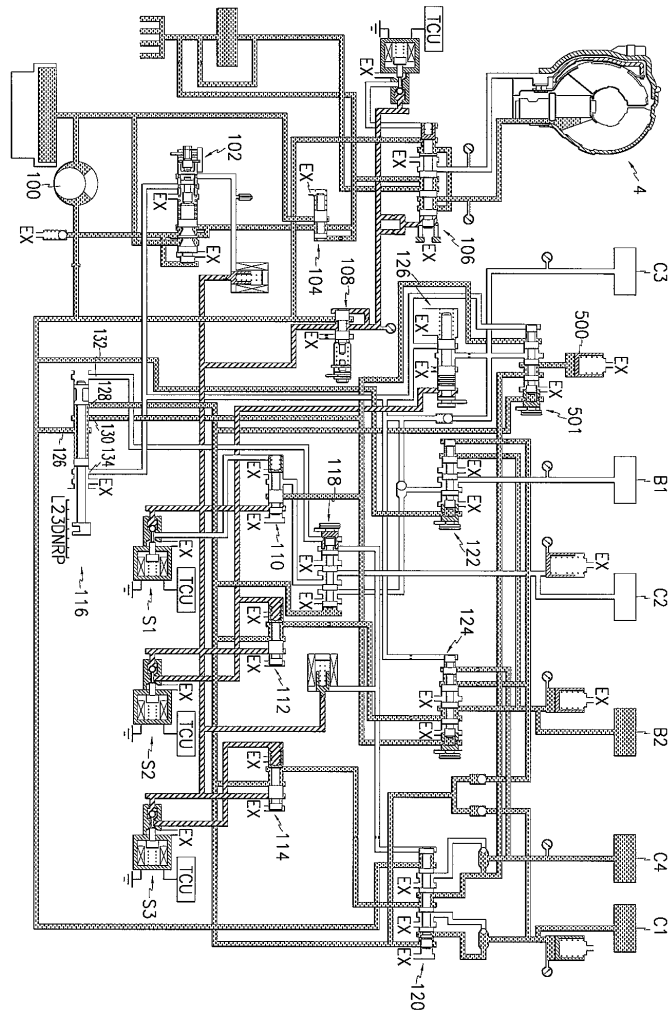

10

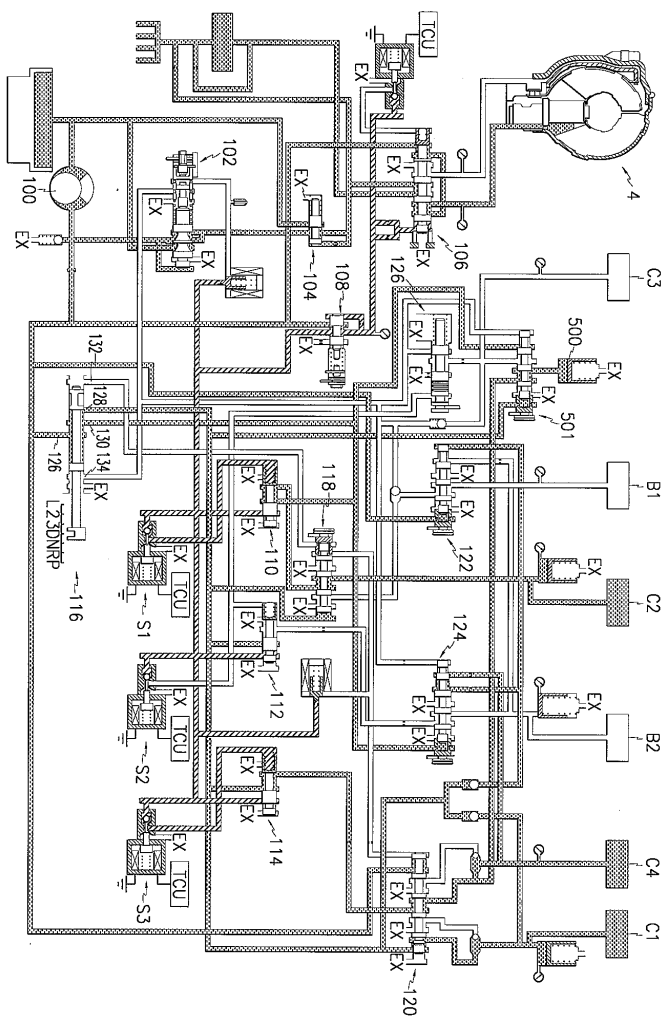

11

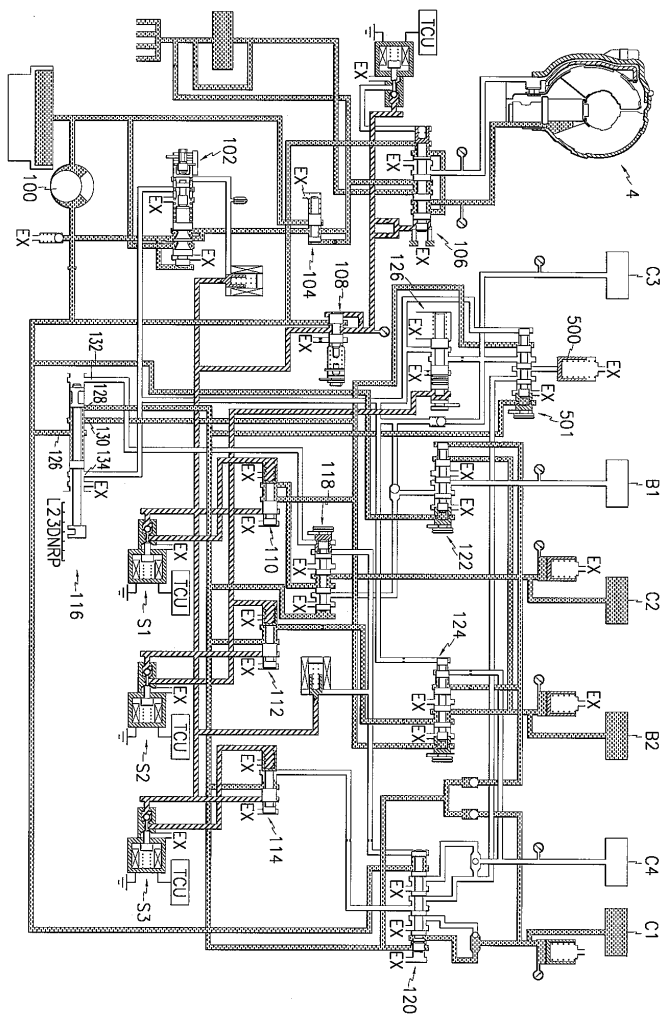

12

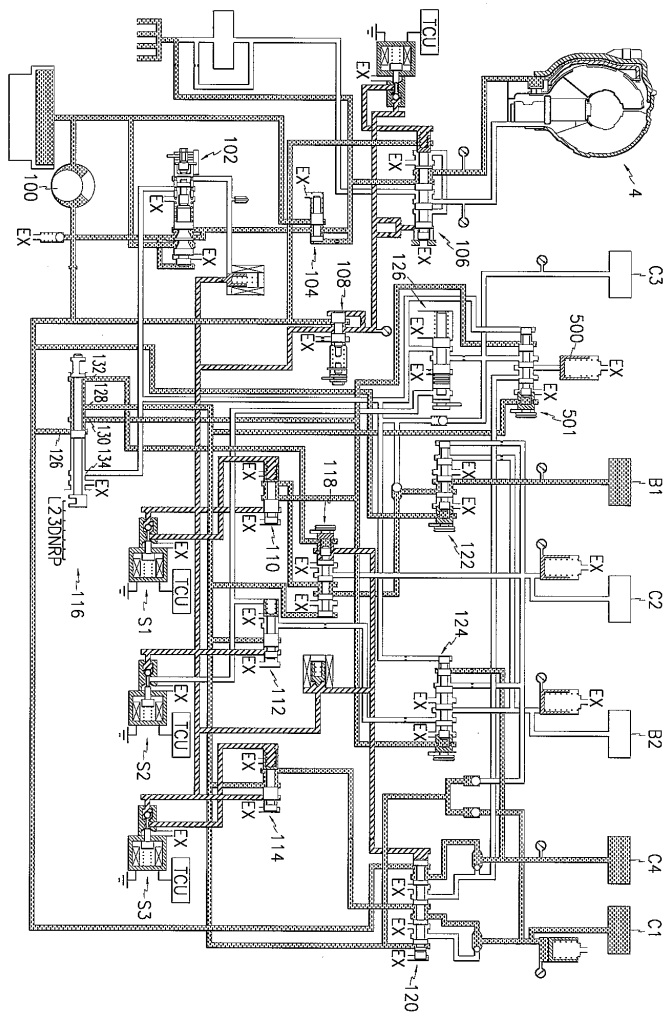

13

