

E. BURNETT, J. F. TURNER & J. C. OATMAN.

BEAN SEPARATING MACHINE.

APPLICATION FILED MAY 1, 1903.

NO MODEL.

2 SHEETS—SHEET 1.

Fig. 1.

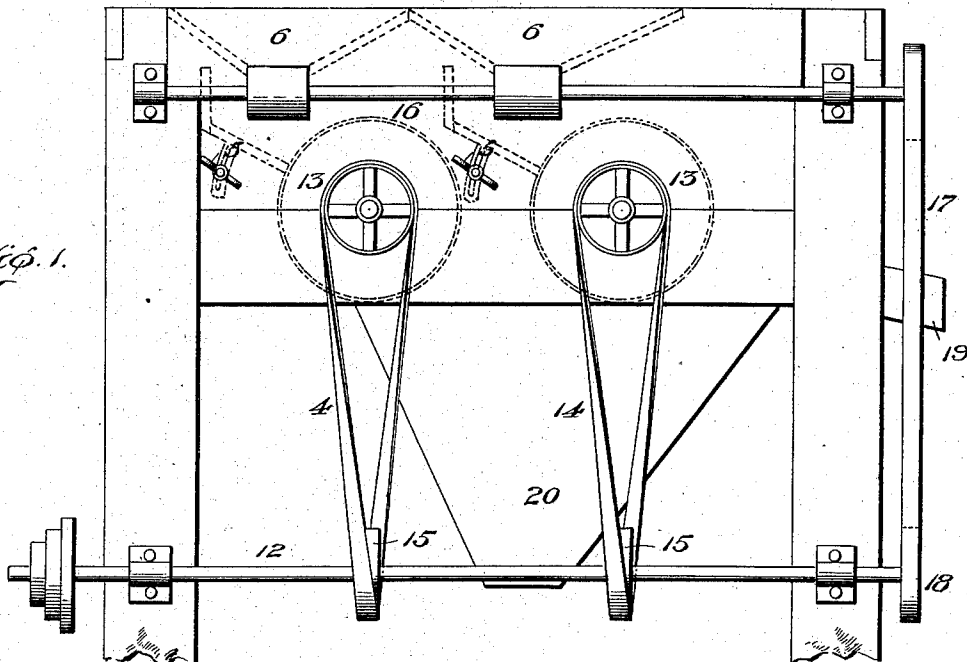
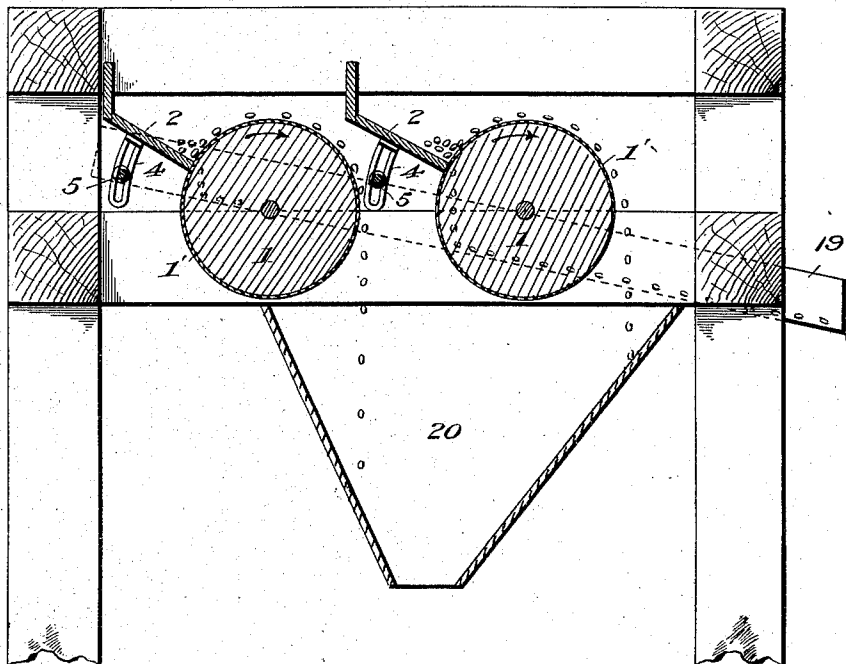

Fig. 2.



Witnesses

Thomas H. Yeager
Thomas H. Yeager

Inventors.

Edward Burnett
John F. Turner
J. C. Oatman
 by *Johnson & Johnson*
 Attorneys

E. BURNETT, J. F. TURNER & J. C. OATMAN.

BEAN SEPARATING MACHINE.

APPLICATION FILED MAY 1, 1903.

NO MODEL.

2 SHEETS—SHEET 2.

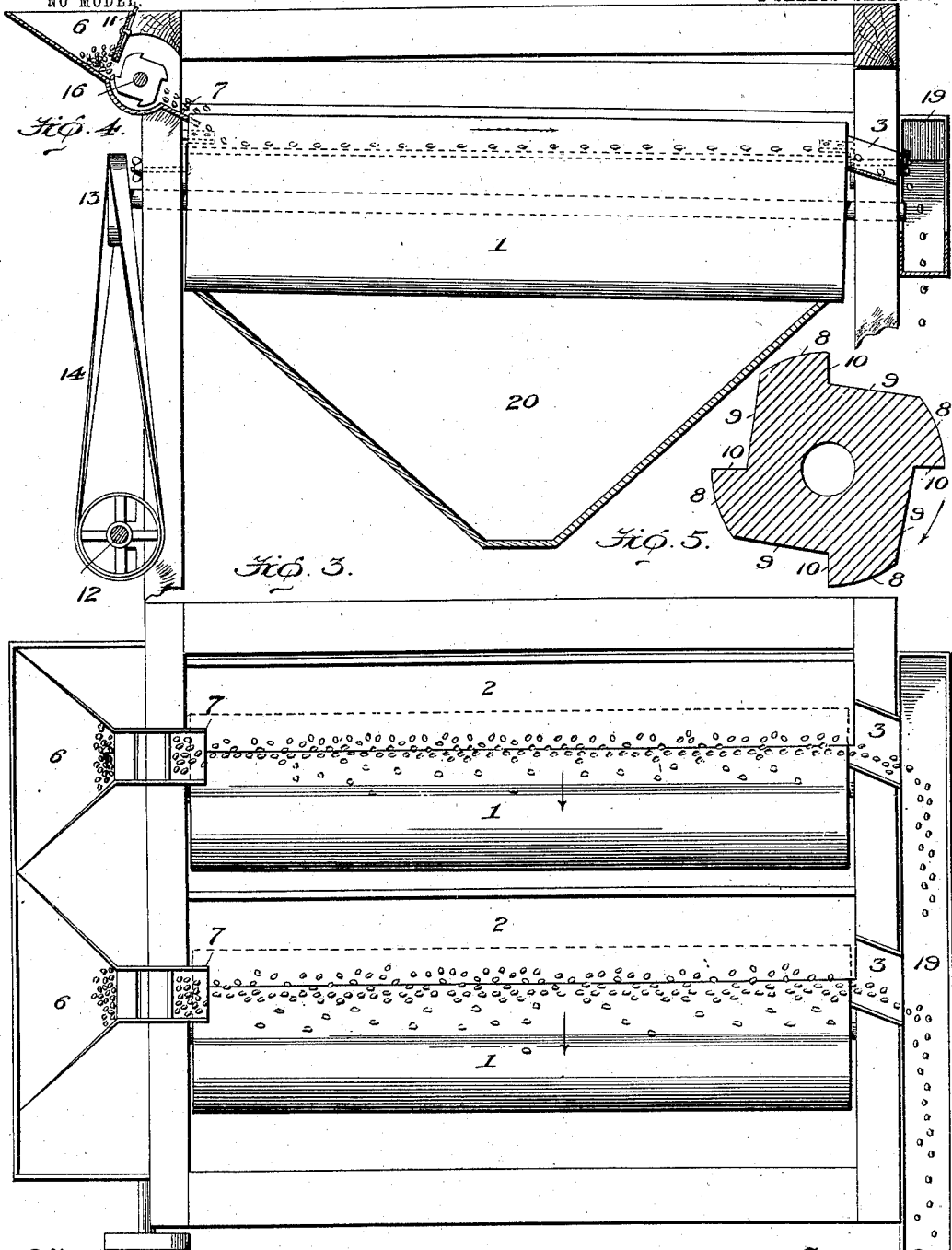

Witnesses
Wm. Ashburn
Thomas H. Yeager

Inventors
 Edward Burnett
 John F. Turner and
 John C. Oatman
 by *James Johnson*
 Attorneys

UNITED STATES PATENT OFFICE.

EDWARD BURNETT, JOHN F. TURNER, AND JOHN C. OATMAN, OF CLIFFORD,
MICHIGAN.

BEAN-SEPARATING MACHINE.

SPECIFICATION forming part of Letters Patent No. 741,956, dated October 20, 1903.

Application filed May 1, 1903. Serial No. 155,159. (No model.)

To all whom it may concern:

Be it known that we, EDWARD BURNETT, JOHN F. TURNER, and JOHN C. OATMAN, citizens of the United States, residing at Clifford, Michigan, have invented certain new and useful Improvements in Bean-Separating Machines, of which the following is a specification.

The invention herein is directed to the production of a machine for separating beans wherein the separation is effected by the rotation of a cloth-covered roll, the function of which is to seize and carry the bad beans upward upon and over the roll from a stream of beans moving against and lengthwise of the roll, the surface of which for this purpose being formed of some suitable fabric that will seize or take hold of the bad beans and deliver them upward over the roll.

The following description read with the accompanying drawings will enable any one skilled in the art to which our invention relates to understand its nature and to practice it in the form in which we prefer to employ it; but it will be understood that our invention is not limited to the precise form and details of construction herein illustrated and described, as various modifications and changes may be made without exceeding the scope of the claims in which our invention is set out.

Referring to the drawings, Figure 1 represents a front elevation of a machine for separating beans embracing our invention, the parts for effecting the separation being shown by dotted lines. Fig. 2 is a vertical section taken transversely of the separating parts. Fig. 3 is a top view of the same. Fig. 4 is a vertical section taken longitudinally of the machine, showing more particularly the relation of the feed-roll to the end of the separating-roll. Fig. 5 shows in cross-section the feed-roll enlarged.

Between the vertical sides of a suitable frame is mounted a roll 1, about thirty-three inches long and from ten to sixteen inches in diameter and is inclined so that at one end it is about three inches lower than the other.

It is covered by a suitable cloth of the desired roughness adapted to the kind and condition of the beans. A feed board or trough is formed along one side of the roll a suitable distance above its axis-line by a table or guide-way 2 and terminates a little beyond its lower end in a chute 3 at the side of the frame. The edge of this table is adjacent to or abuts lightly against the cloth surface of the roll, and it is supported in an upwardly-inclined position from the roll by a curved arm 4, depending from each end of the table and fastened to the inner wall of the frame by a thumb-screw 5, passing through a slot in said arm, whereby to allow of the adjustment of the table to give the trough more or less inclination toward the lowest end of the roll to suit the speed of the roll and to give more or less speed to the stream of beans or to set the table higher or lower in its relation to the top of the roll to vary the distance up which the bad beans are carried on the roll before they are rolled over its highest point. A hopper 6, fixed to the frame, has a concave part which terminates in a chute 7, which overhangs the upper end of the table at its junction with the roll. A feed-roll is fitted to rotate in the concave hopper part, so that it rotates in close proximity to the concave wall, with its upper part in the throat of the discharge-opening. It is important that this feed-roll be constructed to take the beans from the hopper and deliver them upon the table without cutting or bruising, and for this purpose we prefer to use a roll having longitudinal surface recesses, which as the roll is turned receive and feed the beans into the trough formed by the table and the roll. A roll two inches in diameter will give four surface recesses which will provide a comparatively thin continuous stream of beans down the trough, and this division of recesses will give four angular surface projections, each of which has a curved part 8, which forms the circumference of the roll, a flat part 9, which forms the bottom of the recess, and a radial part 10, which joins the

curved surface with the bottom of the recess, so that in the rotation of the roll the beans are caused to fill the recesses and be delivered therefrom by an overshot feed. The feed of the beans from the hopper to the feed-roll may be regulated by an adjustable slide 11, set on the wall of the hopper above the feed-roll.

We have shown a pair of cloth-covered rolls each having an adjustable table and a feed-roll, and separator-rolls arranged in the frame in the same horizontal line and driven by the same power-driven line-shaft 12, each roll having a pulley 13, driven by a band 14 from a pulley 15 on the line-shaft. It is also obvious that a plurality of rolls of different sizes may be used in the same machine, all driven from the same line-shaft. There being a feed-roll for the trough of each separating-roll, a line-shaft 16 is mounted on the outside of the frame, carries each feed-roll, and is driven by a band 17 from a pulley 18 on the line-shaft which drives the separating-rolls, so that by having the pulleys on the line-shafts of the same size the speed of the separating-rolls and the speed of the feed-rolls may be the same or they may be different, as may be desired, to suit different qualities of beans. As each separating-roll has a discharge-chute, the good beans are delivered from each chute preferably into an inclined chute 19, connecting all the roll-chutes with a bin, or into a bag connected to the chute of each roll-trough, while the bad beans are delivered into a wide chute 20, depending from the frame beneath the rolls. The separation of the bad beans from the good beans is the fact that the roughness and irregularity of the bad beans will cause them to catch to the cloth by reason of its roughness, and as the roll rotates much faster than the bad beans will turn over in moving down the table-trough they will be carried up over the roll and fall into the bin, together with any dirt and small seeds or grain which may be gathered with the beans. Moreover, the movement of the roll gives a stirring action all along the stream of beans, turning them over, so that the rough roll-surface will pick out the rough bad beans from the stream and take them up on the turning roll, and for this purpose the table or feed-board is set inclining upward away from the side of the roll in order that the stream of beans may be held and stirred against the cloth surface the length of the roll as it rotates, and it is during the sliding movement of the row of beans down the board and the action of the roll in stirring the beans during such sliding movement that the bad beans are picked from the stream by the roughness of the cloth and carried away from the stream by a movement at

right angles to the direction of the movement of the stream. In effecting this sliding movement of the beans the feed-board must be inclined in the same direction as the roll in order to provide a regular and certain feed, while the vertical adjustment of the feed-board at both ends gives the advantage of setting it the same or at a greater or less inclination than that of the roll and maintain its proper relation to the feed-hopper, to the delivering-chute, and to the top of the roll.

We claim—

1. In a machine for separating beans, the combination of a board inclined laterally and longitudinally, and a rotatable inclined cloth-covered separating-roll in juxtaposed relation to the lower edge of said feed-board and means for adjusting the feed-board at its receiving and at its delivering ends.

2. In a machine for separating beans, the combination of a hopper having a regulable discharge, a laterally and longitudinally inclined feed-board having its high end at the hopper-outlet, means for adjusting the inclination of said feed-board, and a rotatable inclined cloth-covered separating-roll in juxtaposed relation to the lower edge of said feed-board.

3. In a machine for separating beans, the combination of a hopper having a discharge-outlet, a regulable gate at said outlet, a chute leading from the outlet, a longitudinally-ribbed rotatable feed-roll in said chute, a laterally and longitudinally inclined feed-board onto which said chute delivers, and a rotatable inclined cloth-covered separating-roll in juxtaposed relation to the lower edge of said feed-board.

4. In a machine for separating beans, the combination of a hopper, a laterally and longitudinally inclined feed-board having its high end at the hopper-outlet, a rotatable inclined cloth-covered separating-roll in juxtaposed relation to the lower edge of the feed-board, a chute at the low end of said feed-board, and a chute below the roll.

5. In a machine for separating beans and in combination, a frame, a plurality of cloth-covered inclined rolls mounted in said frame transversely thereof side by side on the same horizontal plane, a feed-board arranged in abutting relation to the cloth wall of each roll, standing from each in the same direction and inclined both laterally and longitudinally, a separate hopper for each roll arranged at its highest end, a rotatable feed device for each hopper, a line-shaft arranged at the side of the frame for each feed device, a power-driven line-shaft arranged below and parallel with the shaft of the feed devices, a pulley on the highest end of each separating-roll, corresponding pulleys on the power-

driven shaft, a separate belt for each pair of pulleys, the shafts being connected by a belt and all the pulleys of the same diameter for operating the separating-rolls and the feed
5 devices at the same speed.

6. In a machine for separating beans and in combination, an inclined cloth-covered separating-roll, a feed-board inclined in the same direction as the roll and means for ad-
10 justing the feed-board at a greater or less inclination than the roll while maintaining the

abutting relation of the edge of the board with the wall of the roll.

In testimony whereof we affix our signatures in presence of two witnesses.

EDWARD BURNETT.
JOHN F. TURNER.
JOHN C. OATMAN.

Witnesses:

C. E. BAKER,
E. M. SHERWOOD.