

(No Model.)

T. McDONALD.
OIL BURNER.

No. 515,499.

Patented Feb. 27, 1894.

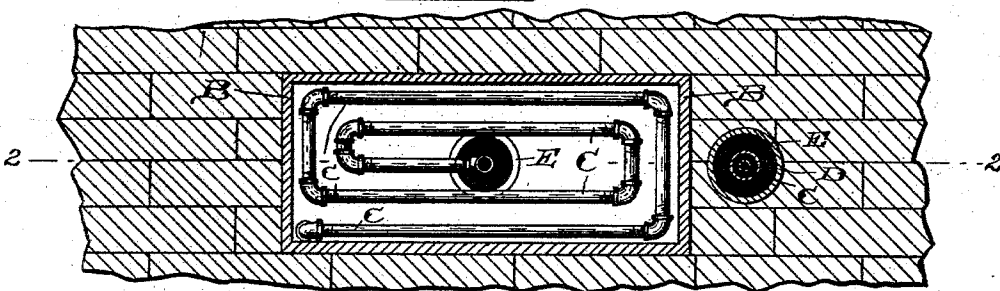
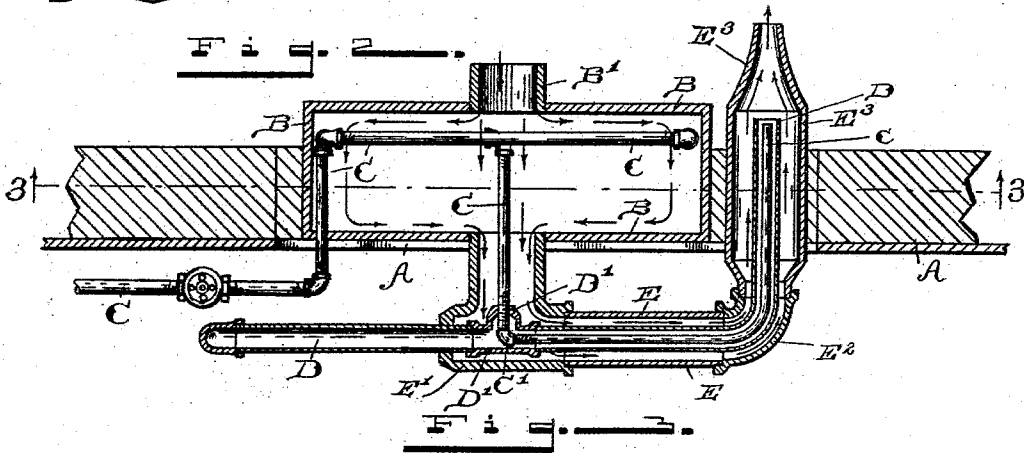
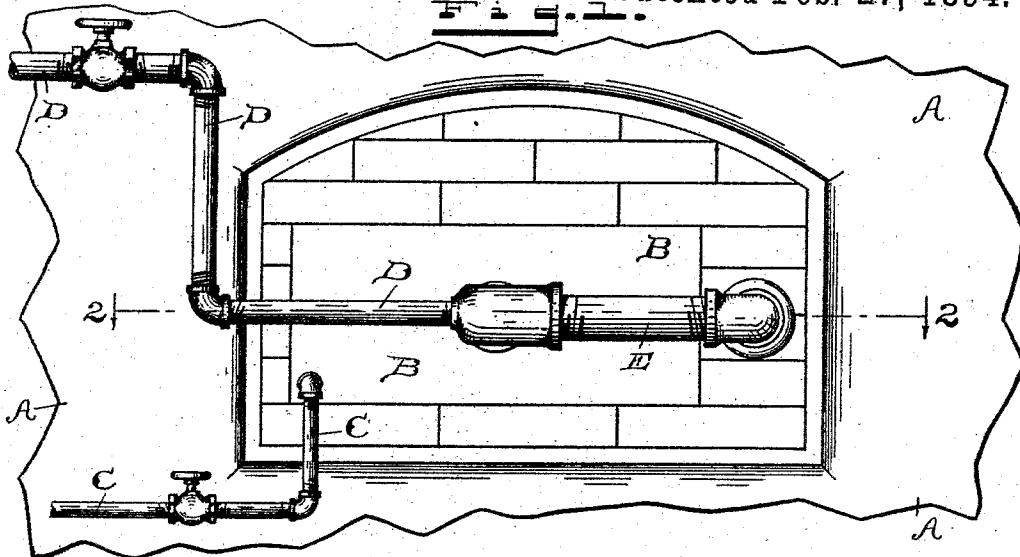

WITNESSES:

F. W. Warner
J. M. Walsh.

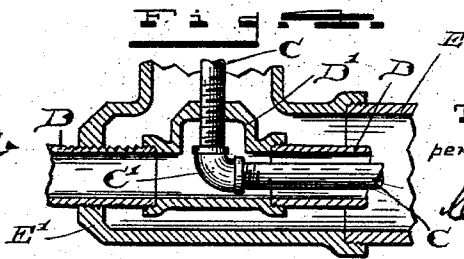

INVENTOR

Thomas McDonald,

per

Chester Melford,
ATTORNEY.

UNITED STATES PATENT OFFICE.

THOMAS McDONALD, OF INDIANAPOLIS, INDIANA.

OIL-BURNER.

SPECIFICATION forming part of Letters Patent No. 515,499, dated February 27, 1894.

Application filed November 15, 1892. Serial No. 452,046. (No model.)

To all whom it may concern:

Be it known that I, THOMAS McDONALD, a citizen of the United States, residing at Indianapolis, in the county of Marion and State of Indiana, have invented certain new and useful Improvements in Oil-Burners, of which the following is a specification.

My said invention relates to certain improvements in that class of oil burners which are commonly used in furnaces, especially under steam boilers, and its object is to provide means whereby the oil can be raised to a high temperature before being discharged with the steam and air into the combustion chamber, and the temperature of the several elements equalized.

It consists essentially in providing a heating box within which the oil pipe shall be coiled before entering the burner; and it further consists in an arrangement by which the steam shall surround said oil pipe for a considerable distance before reaching the point where they both discharge and commingle together.

Referring to the accompanying drawings, which are made a part hereof, and on which similar letters of reference indicate similar parts, Figure 1 is a front elevation of a portion of a furnace or fire box provided with an oil burner embodying my said invention; Fig. 2 a horizontal sectional view looking downwardly from the dotted line 2 2 in Fig. 1; Fig. 3 a vertical sectional view looking upwardly from the dotted line 3 3 in Fig. 2; and Fig. 4 a detail view, on an enlarged scale, similar to a portion of Fig. 2, showing more plainly the couplings which I find it desirable to employ in carrying out my invention, at the points where the several pipes are united.

In said drawings the portions marked A represent a fragment of the wall of a furnace or fire box; B the box which is one feature of my said invention; C the oil pipe; D the steam pipe, and E the air pipe, terminating in a nozzle or "burner" hereinafter known as the "oil burning nozzle," through which the commingled oil, steam and heated air are discharged in the combustion chamber.

The furnace A is, or may be of any ordinary or desired construction. In the drawings is represented a fragment of a cast-iron front, like those commonly employed

with large stationary boilers, with the door removed, and the space (except so much as is occupied by my box) filled with brick. The box B is set in the front wall of the combustion chamber, and preferably projects somewhat within said combustion chamber, as shown most plainly in Fig. 2. Extending still farther within said combustion chamber from said box is a piece of pipe or tubing B', and through this a supply of the heated air is drawn from said combustion chamber into said box, and thence around through the burner, as will be presently described, there being a corresponding opening on the opposite side of said box connecting with said burner. This box incloses and protects the pipes, and, the ingress opening being properly proportioned, enables said pipes to be subjected to the proper amount of heat, and without subjecting them to the intense direct heat to which they would be subjected if they extended directly into the furnace. Were the pipes subjected to the direct action of the furnace at the ordinary heat of such furnace, the oil would be baked and caked therein, instead of being volatilized, and the result would be that the apparatus would be soon rendered inoperative. The oil pipe C enters the box, as shown, and is coiled therein to whatever extent is desired, and passes thence, by means of a coupling, to within the steam pipe. As the box communicates directly with the interior of the combustion chamber through the pipe B', it will be understood that the air which is drawn into said box is of a very high temperature, and the coils of the pipe C are thus heated very hot, thus also heating the oil which is flowing through said pipe. The pipe C continues, by means of the couplings C' and D', to within the steam pipe D, and passes around inside of said steam pipe to just short of the termination thereof; and thus the contents of both pipes are discharged together into the oil burning nozzle. The oil being already heated by passing through the coil in the box B, and being surrounded by the steam from the time it leaves said box until it is finally discharged, the temperature of the oil and the steam is necessarily substantially the same at said point of discharge, which secures superior results. The steam pipe D enters the air pipe

E shortly after it leaves the box B (it may enter it within the box if desired), and is thus within the heated air which is flowing from said box around to the oil burning nozzle 5 from that point to the point of discharge. This arrangement—the oil inside of the steam, and the steam inside of the hot air, with the discharge points close together and arranged as shown—secures a perfect commingling of 10 the several elements before they finally enter the combustion chamber, which necessarily is superior to a less perfect commingling.

The pipe E leads from the box B through couplings E' and E² to the oil burning nozzle 15 E³, which projects into the combustion chamber, and through which the several elements to be burned are driven into said chamber, principally by the force of the steam, where they are consumed.

20 Having thus fully described my said invention, what I claim as new, and desire to secure by Letters Patent, is—

1. The combination, in an oil burner, of a box set into a furnace wall and communicating with the interior of the combustion chamber, an oil pipe passing into and coiled within said box, and thence passing into a steam pipe, said steam pipe, which passes within the hot air pipe, and said hot air pipe, leading from said box to the oil burning nozzle, 30 substantially as shown and described.

2. The combination, in an oil burner, of a box B having an ingress opening extending into the combustion chamber through which a supply of air is drawn, an egress opening 35 leading therefrom and connected by a pipe with the burner, an oil pipe passing into and coiled within said box and passing thence through the egress opening therefrom and the pipe connected thereto into the burner, a 40 steam pipe leading into said last mentioned pipe and surrounding said oil pipe from the point of union also to within the oil burning nozzle, and said nozzle, said several parts being arranged and operating substantially as 45 set forth.

3. In an oil burner, a box set into and forming part of the front wall of the combustion chamber, and communicating with the interior thereof, in combination with a pipe or 50 pipes carrying the elements to be burned, one or more of which pass within said box and are there subjected to heat, and with the oil burning nozzle with which said pipes communicate substantially as set forth. 55

In witness whereof I have hereunto set my hand and seal, at Indianapolis, Indiana, this 11th day of November, A. D. 1892.

THOMAS McDONALD. [L. S.]

Witnesses:

CHESTER BRADFORD,
JAMES A. WALSH.